

MHI

Manual No. '06-SC-T-111

TECHNICAL MANUAL

Collection data

AIR CONDITIONING CONTROL SYSTEM

CENTER CONSOLE

SLA-3-ER (SC-SLA3-ER)

SLB-3-ER (SC-SLB3-ER)

CONTENTS

1. MODEL USED ALL SUPER LINK RELATED MODELS	1
2. SPECIFICATIONS	1
3. ACCESSORIES	1
4. EXTERNAL VIEW	2
5. INSTALLATION	2
6. FUNCTIONS	4
7. ELECTRIC WIRING	9
8. SELECTING A NEW PULSE UNIT	10

These technical manual cover Center Consoles SLA-3-ER and SLB-3-ER. Concerning other air conditioning control systems, see page 675 in Part 5 (Air Conditioning Control System) of the

'06	TECHNICAL MANUAL
	KX-4

Center Console SLA-3-ER, SLB-3-ER

1 MODEL USED ALL SUPER LINK RELATED MODELS

Name	Model	Remark
Center Console SLA-3-ER SLB-3-ER	SC-SLA3-ER SC-SLA3-ER	If the SLA-3-ER and SLB-3-ER is buried, it must be installed in a separately sold box (SLA3R-BX).

2 SPECIFICATIONS

Item		Model	SLA-3-ER, SLB-3-ER ⁽⁹⁾
Ambient temperature during use			0 ~ 40 °C
Power supply			1 Phase 100V/200~240V 50Hz/60Hz
Power consumption			17 W
External dimensions (Height×Width×Depth)			162 mm × 240 mm × 110 mm
Net weight			2 kg
Maximum number of connectable units (Indoor units)			Maximum 48 units/system 3 systems = 144 units
LCD touch panel ^{(4), (5)}			Color LCD, 7 inches wide
Inputs	SL (Super link) Signal inputs		3 systems
	Gas, Power pulse input ⁽²⁾		8-point pulse width 100 ms or more
	Fire signal input ⁽²⁾		1 point non-voltage a contact input continuous input (closed, forced stop)
	Demand signal input ⁽²⁾		1 point non-voltage a contact input continuous input (closed, demand control)
Outputs	Simultaneous operation output		1 point maximum rated current 40 mA, 24 V During full stop: Open; If even 1 unit is operating, Closed
	Simultaneous error output		1 point maximum rated current 40 mA, 24 V Normal: If even one unit is abnormal, Open ⁽⁶⁾
Use with other central control units			(8)

Notes (1) Some functions cannot be used depending on the indoor model used.

(2) The receiving side power supply is DC 12 V (10 mA).

(3) If the energy consumption calculation function is necessary, use the SLB-3-ER.

(4) The lifetime of the keying of touch panel is one million times.

The lifetime of LCD is about 20,000 hours, depending also upon the backlight OFF time setting. (The brightness will become half of the starting value.)

(5) The touch panel has an endurance of approximately 1 million times.

(6) In the environment setting screen, it is also possible to change the batch error output setting as open for normal and closed for error.

(7) The air conditioning charges calculations of this unit are not based on OIML, the international standard.

(8) • The center console SLA-2A series can be connected 1 unit per system.

• It cannot be combined with the center console SLA-1 series, SLA-200 series and the CHC-M series, SC-WGW-A series, SC-BGW-A series or SC-LIF series, SC-LGW-A series.

• Multiple SLA-3-ER and SLB-3-ER units cannot be connected on the same network.

(9) SLB-3-ER cost calculation results cannot be guaranteed.

(10) Working Environment

• Operating System

Microsoft® Windows® 2000 SP3, 4
Windows® XP

• Hardware

Pentium 300 MHz or greater
128 MB RAM
5 MB free hard disk space
1 USB (1.1 or 2.0) port

3 ACCESSORIES

Center console	1 unit
Pan head screw (M4)	4 pieces for installing on the control board (10 mm)
Pan head screw (M4)	4 pieces for embedding in a wall (40 mm)

User's manual (CD-ROM)	1 unit
Installation Instruction manual	1 unit
Terminal	2 pieces

In case of embedding in a wall, the special box (SLA3R-BX) for embedding in a wall is required. (sold separately)

• For SLB-3-ER

SLB-3-ER utility (CD-ROM)	1 unit
---------------------------	--------

USB Memory	1 unit
------------	--------

4 EXTERNAL VIEW

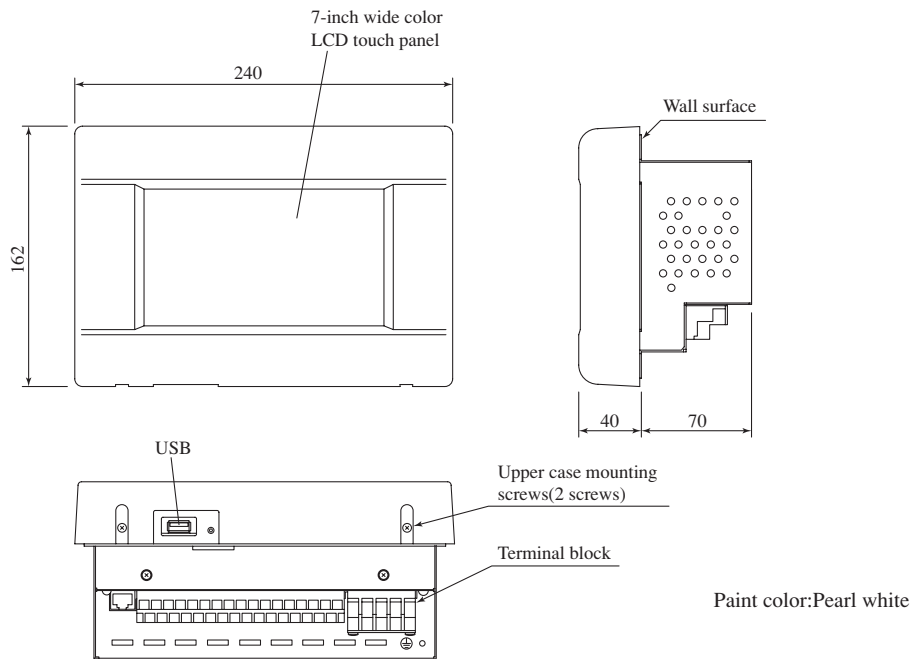

5 INSTALLATION

Before the installation, shut off the power supply to avoid an electric shock.

Please locate or protect so that the unit will not be forced against wiring.

(1) Installation place

Install this unit indoors without the influence of the electromagnetic wave, or splashing such as water and dust.

Necessary clearance is 200mm or more beneath the center console and 500mm or more in front of the center console.

(2) Installation space

Please choose one of two ways.

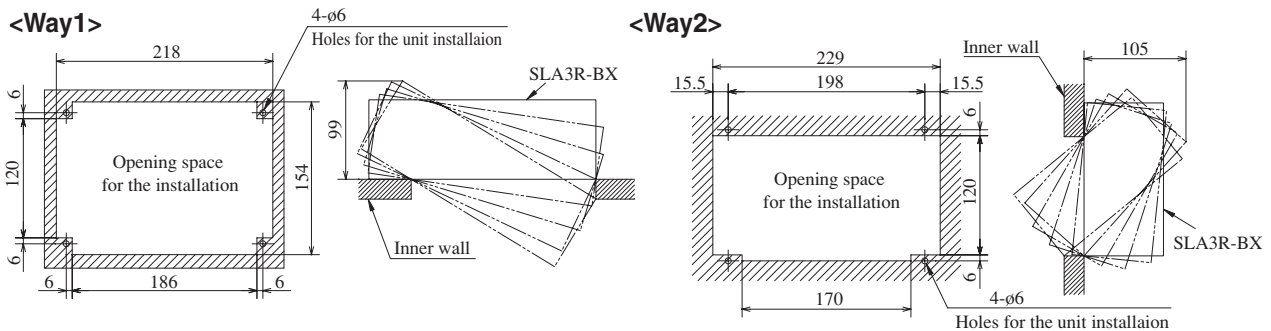

(a) In case of installing on the control board

- 1) Please use the control board of the size of 300mm × 400mm × 120mm or larger.
- 2) Please be sure to lock the control board to protect persons from the electric shock.
- 3) Please do not use any heat insulation material on the control board.
- 4) If you use it, accumulated heat will cause the center console to malfunction.

(b) In case of embedding in a wall

Please be sure to use the special box, SLA3R-BX (sold separately) to secure sufficient air circulation space. If the box is unused, the center console will not work properly because of heat buildup inside the box. Please be sure to use for protecting persons from the electric shock. Please check that the sufficient space is available in the wall.

When the inside of the wall is divided and have a cavity, please create space more than 0.08m³. Refer to the next page.

If there is no partition on the left, right, top and bottom of the center console, please create a space that is 105mm or deeper.

When you cannot create the sufficient space or thickness of the wall is above 15mm, please install the center console on the control board.

<No partition>

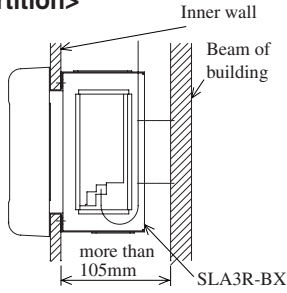

<With partition>

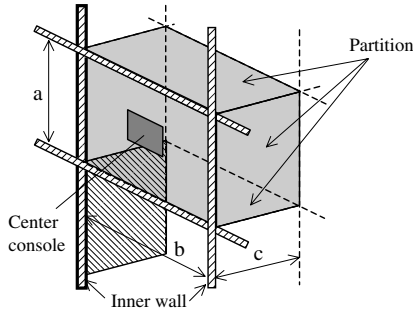

●SLA3R-BX (Sold separately)

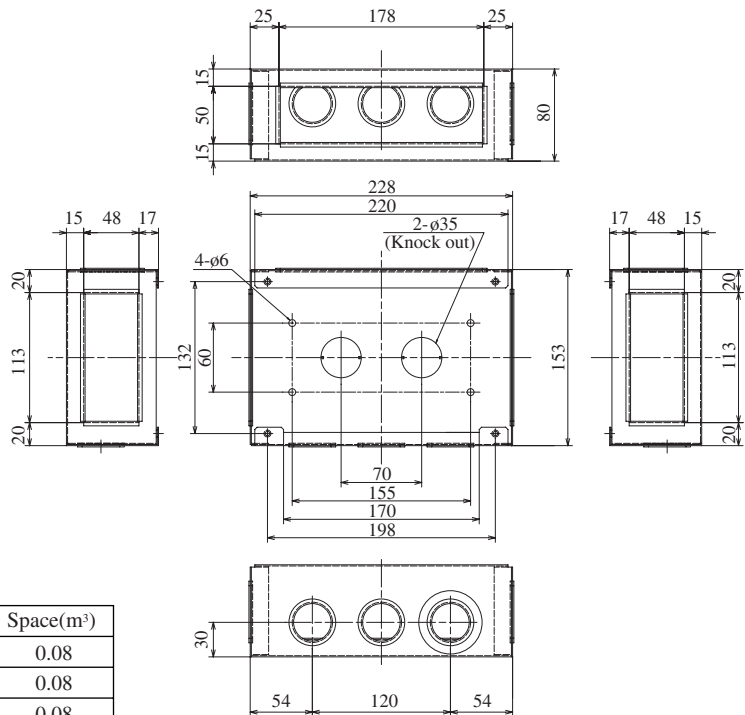

	a(Height)(mm)	b(Width)(mm)	c(Depth)(mm)	Space(m ³)
Example1	900	800	110	0.08
Example2	1800	400	110	0.08
Example3	1000	400	200	0.08
Minimum	600 or larger	400 or larger	110 or larger	

(3) Installation method

- (a) Embed signal wire and power supply wire in a wall beforehand.
- (b) Connect wires to the terminal block.
- (c) Confirm power supply voltage and connect correctly.
- (d) Remove the upper case
 - 1) Take out two screws using a cross slot screwdriver. (Don't lose the screws)
 - 2) Pull the upper case a little forward and push above. Then, upper case can be removed.

① Caution

Please do not install facing upward or in slanted position.

Correct

Incorrect

Incorrect

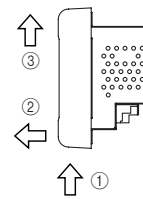

- (e) In case of installing on the control board

① Caution

Please do not install other units on the same control board that will cause temperature rise.

② Caution

Please do not install multiple controllers on the same control board. They can cause the temperature rise of the control board interior and the center consoles will not work properly. When there is no choice but to install the multiple controllers, please adjust the temperature inside the control board 40 degrees or less. (for example cooling fan installation)

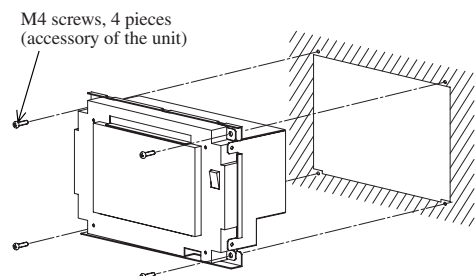

Fix the unit to the SLA3R-BX with the M4 screws. (4 places)
Wire separately the power supply wire and the signal wire for preventing malfunctions.

- (f) In case of embedding in a wall

Please be sure to use the special box, SLA3R-BX (sold separately).

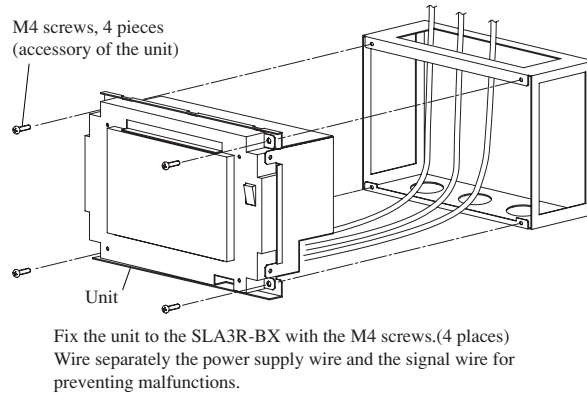
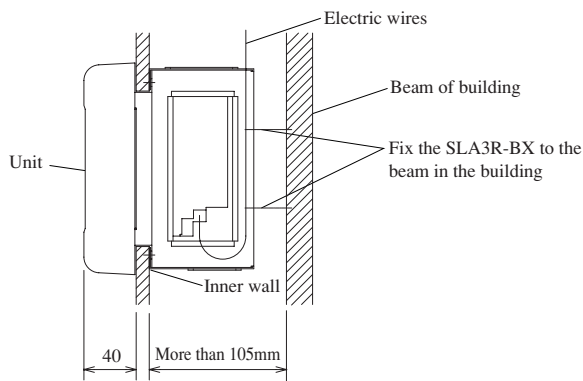

6 FUNCTIONS

(1) Operation, Settings

Carries out batch operation and settings in group units for up to 144 groups. It is necessary that the groups for which batch operation and settings are carried out be set in advance.

No.	Item	Contents
1	Run/Stop	Starts or stops operation.
2	Mode	Sets COOL, HEAT, DRY, FAN and AUTO ⁽¹⁾ operation.
3	Set temperature	Sets the temperature in a range of 18 °C ~ 30 °C (in 1 °C units).
4	Operation permitted/prohibited ⁽²⁾	Enables or disables manual operation, enables or disables run/stop operations, enables or disables mode setting and enables or disables temperature setting.
5	Fan speeds	Sets Hi, Me or Lo fan speed.
6	Air direction	Sets auto swing ON or OFF and sets positions 1 ~ 4.
7	Filter reset	Resets (turns off) the filter sign.

Notes (1) This function can be applied to the outdoor units, which are the cooling/heating free multi KXR, GHP-R series or later and PAC.

(2) This function can be applied to the indoor units, which are the model KXE4 or later, and to the remote controller, which is the model RC-E1 or later.

(3) This enables or disables permitting and prohibiting the individual operation such as RUN/STOP mode and temperature settings of the remote controller.

(2) Status monitor

Status monitoring is carried out in block units (only monitored operating state and breakdown), group units or air conditioner units.

No.	Item	Contents
1	Operating state	Monitors the operating and stopped state of the air conditioner. When 1 or more units is running, it shows operation and when all units are stopped, it shows that operation is stopped.
2	Mode	Displays the operation mode of a representative air conditioner.
3	Set temperature	Displays the set temperature of a representative air conditioner.
4	Room temperature	Displays the return air temperature of a representative air conditioner.
5	Operation enabled	It shows whether manual operation, the run and stop operation, mode setting and temperature setting are enabled or disabled of a representative air conditioner.
6	Fan speeds	Displays the fan speed setting for a representative air conditioner.
7	Air direction	Displays the auto swing ON/OFF setting and position setting for a representative air conditioner.
8	Filter sign	Displays the filter sign if the filter sign for one or more units is lighted up. When the filter sign is off for all units, the monitor's filter sign goes off.
9	Maintenance (Inspections 1, 2 or backup)	Displays the maintenance indicator when the <Inspection 1, 2 or backup> lights up on 1 or more units. When <Inspection 1, 2 or backup> is off on all units, the maintenance indicator goes off. Three are 3 types of inspection, 1, 2 and backup. The display priority order for these three types is as follows. Backup > Inspection 1 > Inspection 2
10	Breakdown	Displays the breakdown indicator when one or more units has broken down. When all units are normal, the breakdown indicator goes off.

(3) Setting the schedule

The operation schedule can be set in group units. In one day, up to 16 schedules can be registered for operation time, run/stop, mode, operation enable, and temperature settings. Operation time settings can be set in minute units.

No.	Item	Contents
1	Yearly schedule	Set the schedule for one year as weekdays, holidays, special day 1 and special day 2.
2	Today's schedule	Sets the schedule that will be valid for the current day only. This schedule has priority over annual schedules.
3	Special day schedule	Sets each schedule of weekday, holiday, special day 1 and special day 2 in the yearly schedule.

(4) Administration, Control

No.	Item	Contents
1	Block definition	<p>Sets the block name and the groups constituting the block. The groups registered in a block must first be registered by group definition. Groups that are not set in blocks cannot be set in detail from the display of all blocks or their status displayed.</p> <ul style="list-style-type: none"> • Maximum number of blocks is 16 • Maximum number of groups per block is 9 • Maximum number of characters in a block name is 16 characters. <p>The initial state is with all blocks not defined.</p>
2	Group definition	<p>Sets the group name and the air conditioners constituting the group (up to 16 units per group), a representative air conditioner, and whether the group is controlled simultaneously or not. Air conditioners which are not set in groups are not subject to control by SLA-3-ER or SLB-3-ER.</p> <ul style="list-style-type: none"> • Maximum number of groups is 144 • Maximum number of air conditioners per group is 16 • Maximum number of characters in a group name is 16 characters. <p>In the initial state, 1 air conditioner is assigned to 1 group, and the air conditioner number is for the group name.</p>
3	Unit definition	The type of energy consumption and capacity of each air conditioner connected to SLB-3-ER, and whether it is subject to demand control or not, are set.
4	Time and data setting	Sets the clock used for the schedule, etc. Annual (Anno Domini) / Month / Day / Hour (24 hr. system) / Minute
5	Alarm history	Displays the error occurrence and recovery history for up to 300 occasions in air conditioner units.
6	Energy consumption calculation period	Sets the "regular hours" time bands used for calculation.
7	Energy consumption calculation cumulative operation time	Calculates the cumulative operating hours for each air conditioner, dividing them between "regular hours" or "irregular hours," and saves them.
8	Demand control	"Starts the fan" or "Prohibits operation" for air conditioners which have previously been set by external demand signals. The air conditioners return to their original status (Mode and operation permitted/prohibited) when the demand signals are cancelled.
9	Emergency stop	Causes all the air conditioners connected to this unit to "Stop" or "Prohibits operation" in response to an external emergency signal. When the emergency signal is cancelled, the air conditioners return to their original setting permitting or prohibiting manual operation, but all unit remain in the "Stop" state.
10	Power failure recovery control	When the power is turned on again after a power failure, the groups set in the schedule operate in accordance with the schedule that was set most recently prior to the power failure. If Run/Stop, the operation mode, operation permitted and set temperature items are not set and "----" is displayed for that item, the time is set to the time that was closest to the time of the power recovery. If there is no schedule setting for the affected date, in the air conditioner's default state, all the remote controller operation enabling settings are enabled. Also, it is not necessary to reset the current time if there is a power failure in which the power goes off for a period of less than 48 hours.

(5) Energy consumption calculation data (SLB-3-ER)

SLB-3-ER outputs energy consumption calculation data using USB memory. These data can be edited using commercial spreadsheet software.

Energy consumption calculation data are created for each individual month.

<Calculation procedure>

- ① The cumulative operating time is calculated for each air conditioner. (in minutes)
- ② The total operating time (Ki) for each air conditioner, and the operating time in each time band (regular hours, irregular hours) are calculated (in minutes).

$$K_i = K_i + K_M$$

K_M = Amount of air conditioner operation in 1 minute.

The amount of operation is calculated by the following 3 methods.

The amount of operation in the case calculated for the rated opening area value for that air conditioner, E.

- MULTI 1: The conversion value considering the amount of refrigerant flowing in the indoor unit is calculated (ΣE_j).
(E_j : Conversion value for the opening area of the indoor unit's expansion valve.)
- MULTI 2: The time that refrigerant flows through the indoor unit is additionally calculated. (Thermostat ON time \times E)
- RUN/STOP: A conversion value for the time when the remote controller is ON is added. (Operating time \times E)
(E: Conversion value for the capacity of the indoor unit.)
 - Use the same kind of flow volume for the same type of dynamic flow meters (gas meters).
 - If MULTI-1 and MULTI-2 are set, indoor units in the blower mode cease to be objects of proportional division.
Set indoor units in the blower mode to ON or OFF if you want to make them objects of proportional division.
 - As for the standby power in the case that the air conditioner is not used at night, etc. proportional division cannot be applied if there are no indoor units running, so the standby power readings will not match. Recalculate using spreadsheet software.
- Simple software is included for editing the energy consumption calculation data. See the included software concerning the operation method.
- Energy consumption calculation data are obtained from this unit using the USB memory.
(SLB-3-ER does not recognize commercial USB memory.)

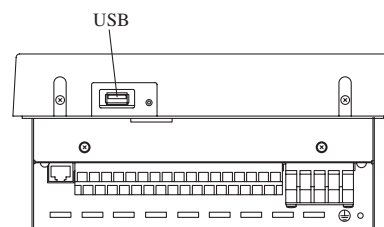

Bottom of the unit

(Example) Method of proportional distribution in case of indoor units A, B, C operating as follows (the shaded part indicates the accumulated operating volume).

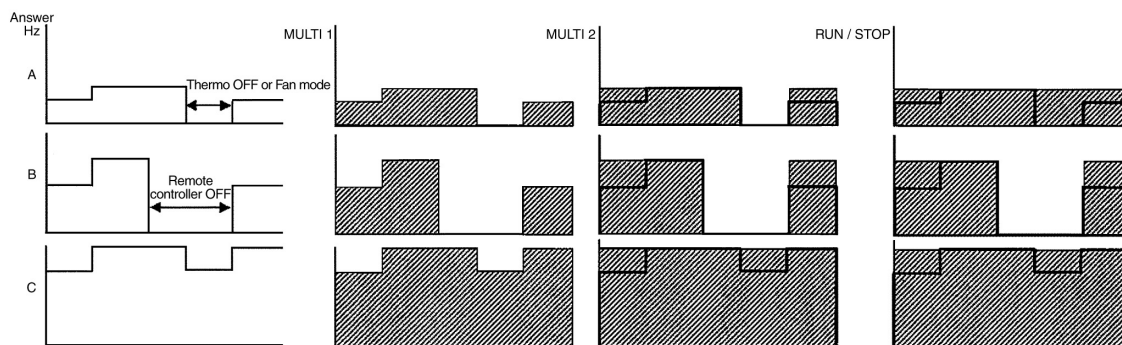

- ① In case of MULTI 1 setting: Conduct proportional distribution according to the results of accumulated answer Hz. Accumulation is not performed when the thermo is OFF or during the Fan mode operation.

Indoor unit A	Indoor unit B	Indoor unit C
25Hz	40Hz	60Hz

Total value of operating volume

(Total value of answer Hz)

$$\text{Operating volume of indoor unit A} = \text{accumulated pulse counts} \times \text{power consumption per pulse} \times 25 / 125$$

$$(25 + 40 + 60)$$

$$\text{Operating volume of indoor unit B} = \text{accumulated pulse counts} \times \text{power consumption per pulse} \times 40 / 125$$

$$\text{Operating volume of indoor unit C} = \text{accumulated pulse counts} \times \text{power consumption per pulse} \times 60 / 125$$

- ② In case MULTI 2 setting: Conduct proportional distribution according to the Hz corresponding to the air conditioner capacity (capacity equivalent Hz: fixed value) and thermo ON operating time.
Capacity equivalent Hz: equivalent value of answer Hz when exerting the indicated capacity of indoor unit (fixed value determined according to capacity).

Different from ①, the fixed value is accumulated irrespective of the answer Hz. Accumulation is not performed when the thermo is OFF and during the Fan mode operation.

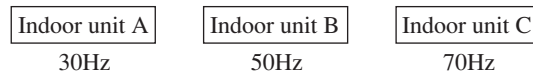

Total value of operating volume
(capacity equivalent Hz × thermo ON time)

Operating volume of indoor unit A = accumulated pulse counts × power consumption per pulse × 30 / 150
(30 + 50 + 70)

Operating volume of indoor unit B = accumulated pulse counts × power consumption per pulse × 50 / 150

Operating volume of indoor unit C = accumulated pulse counts × power consumption per pulse × 70 / 150

③ In case of RUN/STOP setting: Conduct proportional distribution according to the Hz corresponding to the air conditioner capacity (capacity equivalent Hz: fixed value) and remote controller ON time.

Same as ②, the capacity equivalent Hz (fixed value) is accumulated according to the remote controller ON time only. Accumulation is also performed when the thermo is OFF and during the air supply operation.

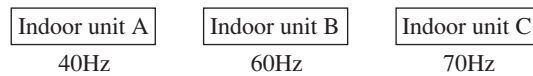

Total value of operating volume
(capacity equivalent Hz × remote controller ON time)

Operating volume of indoor unit A = accumulated pulse counts × power consumption per pulse × 40 / 160
(40 + 50 + 70)

Operating volume of indoor unit B = accumulated pulse counts × power consumption per pulse × 50 / 160

Operating volume of indoor unit C = accumulated pulse counts × power consumption per pulse × 70 / 160

★ User login

For owners the fee apportionment for multi machine air conditioners is more complicated and harder to explain to customers. In many cases it's best to use simple explanations.

In addition, consumption for multi machines are calculated based on volume, making it easy for excessive cooling and differences in building load to lead to discrepancies in electricity consumption.

These different values are hard to explain. Therefore, it is easier to explain how many horsepower were used for how long.

At this point, recommend [RUN/STOP] registration.

Both multi machines and single machines use [RUN/STOP] registration.

Recommend that separate electricity meters be installed for single machine and multi machine systems.

Display every unit of electricity (kW) on the electricity consumption board. For example, register P280H as 28.0.

Current operational value = electricity volume × time of operation, calculated according to the electricity volume ratio.

<Flow of data processing>

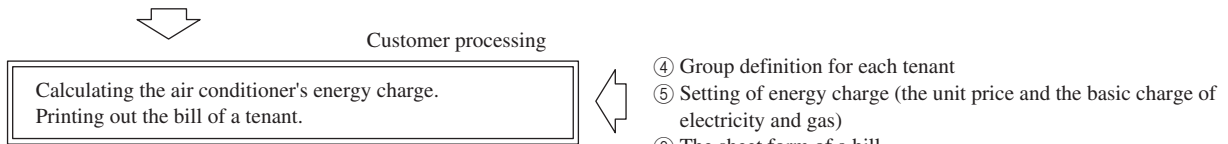
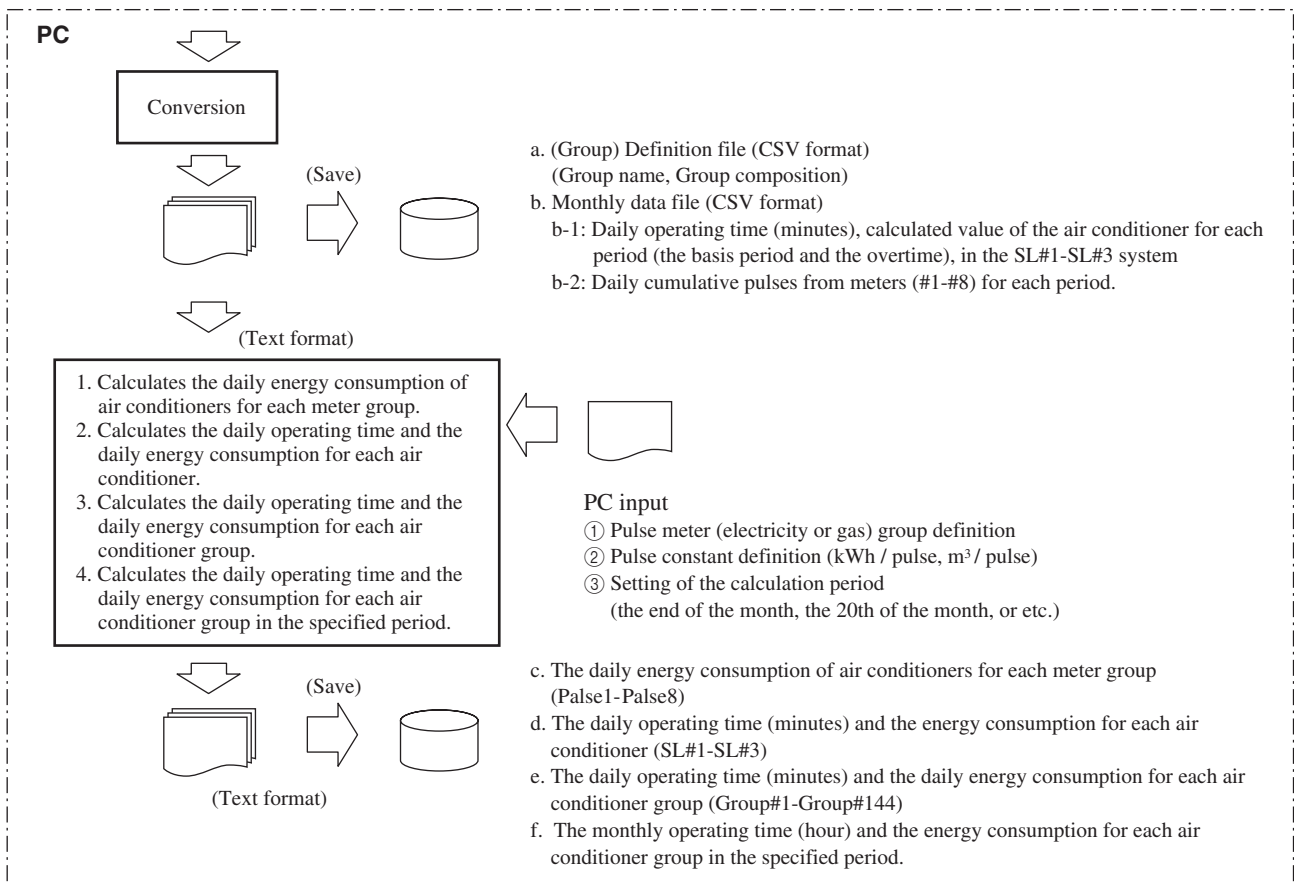
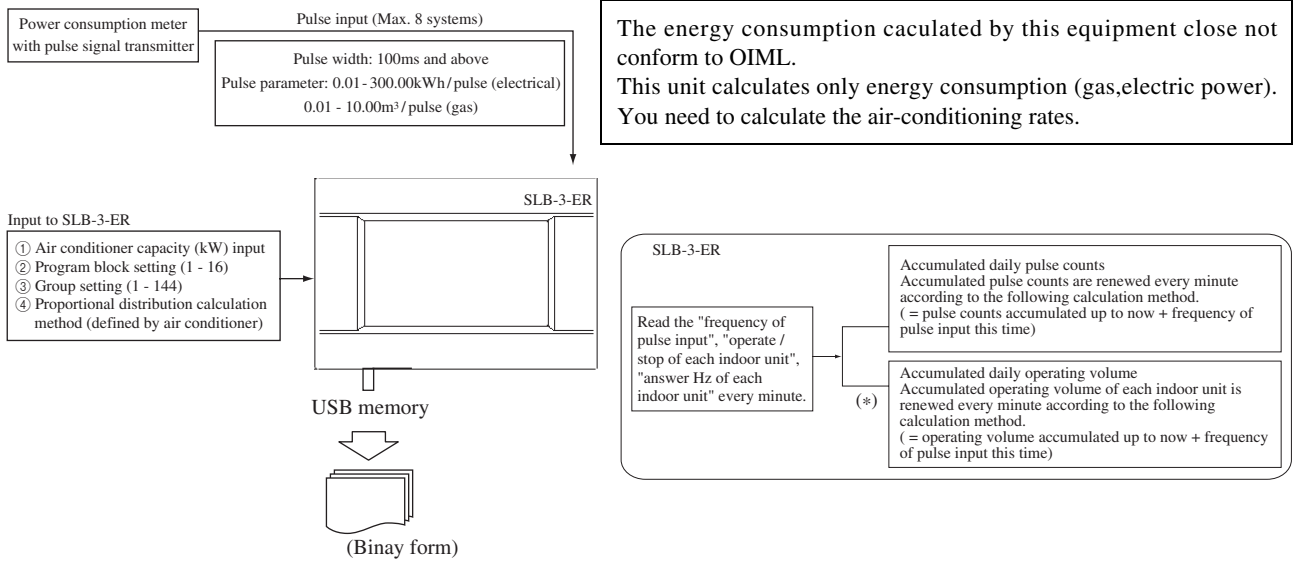

Note (1) The calculation results for the SLB-3-ER are not guaranteed.

Working Environment

- Operating System
Microsoft® Windows® 2000 SP3, 4
Windows® XP
- Hardware
Pentium 300 MHz or greater
128 MB RAM
5 MB free hard disk space
1 USB (1.1 or 2.0) port

7 ELECTRIC WIRING

For safety's sake, use the round crimping terminal with the insulation sleeve for wiring to the unit.

- Perform ground wiring. Please do not connect the ground wire to the gas pipe, the water pipe, the lightning rod, and the telephone ground wire.
- Please do not turn on the power supply (hand switch) until all work finishes.
- Please turn on the power supply two minutes or more after turning on the power supply of the indoor unit and the outdoor unit.
- All wiring, switches, relays, power supply, and lamps, shown in the figure, besides SLA-3-ER (SLB-3-ER), are to be purchased.
- A readily accessible disconnect device shall be incorporated in the building installation wiring.
- Please be sure to use the terminals that comes with this unit for wiring to the terminal block of the power supply.

(1) Wiring outline

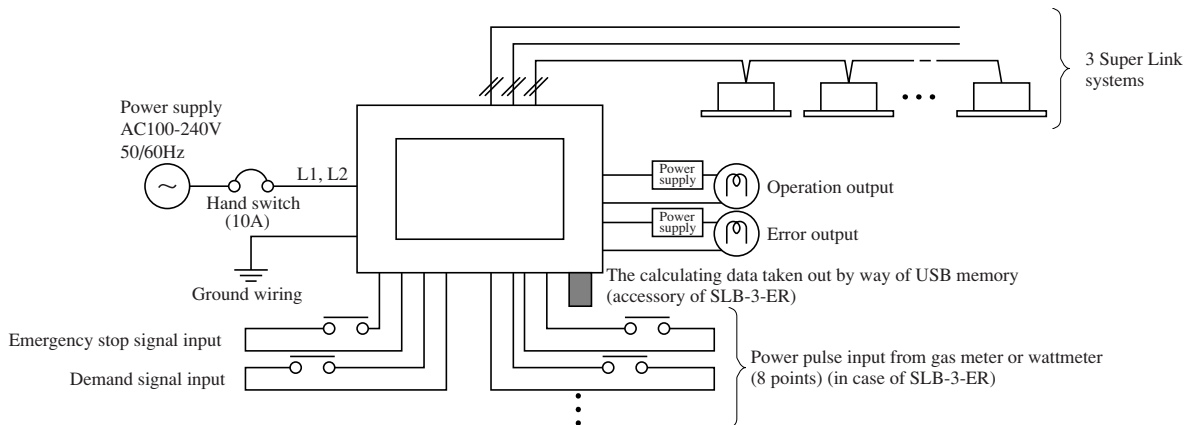

(2) System wiring

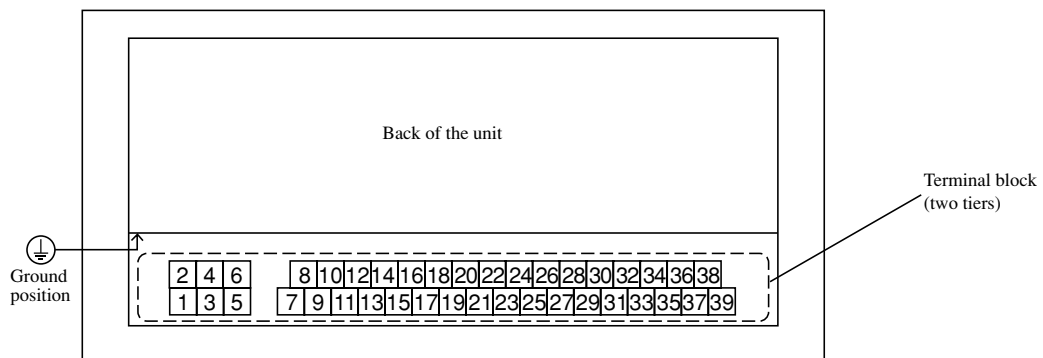

(a) The upper tier of terminal block

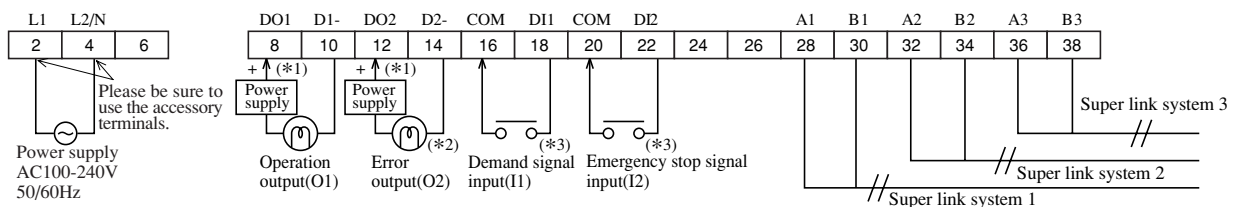

- Note (1) (*1) Power supply : DC 24V maximum rating current : 40mA.
 (2) (*2) Factory default of error output (normal operation) is closed status. You can choose "Open" status for malfunction output during normal operation. Please refer to the user's manual.
 (3) (*3) No-voltage a-contact input Contact capacity : DC12V, 10mA.

(b) The lower tier of terminal block

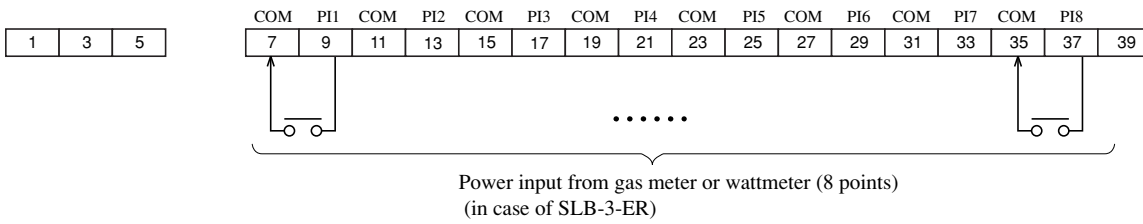

Note (1) Do not connect power supply wire to another terminal block. When you connect by mistake, damage and damage by fire of the electric part are caused, and it is very dangerous. Please check the wiring thoroughly again before it turns on power.

(2) Please connect the gas meter or the wattmeter that satisfies the specification below.

- The meter with pulse transmitter.
- The meter with pulse width of 100 ms or more.

The energy consumption calculated by this unit does not conform to OIML, and there are no guarantees concerning the results of the calculations.

(3) Signal wire for super link

- Size; 0.75mm² ~ 2.0mm²
- The total length of the signal wires should be 1000 m or less. (per line)
- Recommended signal wire list

No.	Name	Symbol
1	Vinyl cabtire roudg cord	VCTF double-core 0.75 to 2 mm ²
2	Vinyl cabtire round cable	VCT double-core 0.75 to 2 mm ²
3	Control vinyl insulated, vinyl sheathed cable	CVV double-core 0.75 to 2 mm ²
4	Shielding wire	MVVS double-core 0.75 to 2 mm ²

When No. 4 shielding wire is used, always ground the single wire side of the shielding wire. In addition, using the shielding wire is helpful to prevent the incorrect connection between 5V DC and 220/240V AC because the discrimination from the power supply wire is clear.

(4) Other signal wire

- Size; 0.75mm² ~ 1.25mm²
- Maximum extension: 200m

(5) Power supply wire

- Size; 1.25mm²

(6) Round eye-let terminal (Terminals other than the power supply terminals.)

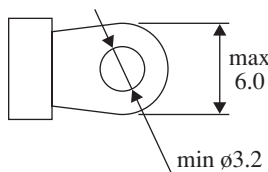

8 SELECTING A NEW PULSE UNIT

(a) Input acceptor restrictions

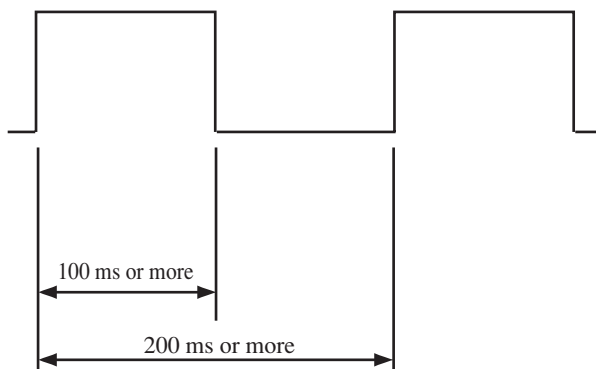

- Machine restrictions
- 1second : 5 pulses or fewer
 - 1minute : 300 pulses or fewer
 - 1day : 1 pulse or more

(b) Pulse unit selection

- ① Find the total capacity of all connected air conditioners
- ② Assume that the correct electricity meter is being used
- ③ Air conditioners operating at full load: assume summer overload power consumption $\times 1.2$

For example, Set the total electricity consumption = 100kW, power rate = 90%

Operating at full load = $100 \times 1.2 = 120\text{kW}$

With 3 in conjunction, $I = 120 \times 1000 / (1.732 \times 200 \times 0.9) = 385\text{A}$

→ Electricity meter must be 400A

If you use 400A Mitsubishi transmission equipment, then

- K11 type, pulse unit at 100kWh/P
select while at 10kWh/P
- K11 type, pulse unit at 100kWh/P
10kWh/P
select while at 1kWh/P
- There are other products with smaller pulses, ask an electric meter manufacturer for details.

- ④ Inspection while electricity consumption is at 120kWh

- When pulse input is highest

Use 0.1kWh/P, then $1200\text{P/h} = 20\text{P/min}$ exactly 1 minute 20 pulse (300pulses or fewer)

10 minutes 200 pulses OK

Use 1kWh/P, then $120\text{P/h} = 2\text{P/min}$ exactly 1 minute 2 pulses

10 minutes 20 pulses OK

Use 10kWh/P, then $12\text{P/h} = 0.2\text{P/min}$, so 1 minute no pulses

10 minutes 2 pulses OK

- Lower usage rate, for example 1/10 time (12kWh),

Use 0.1kWh/P, then $120\text{P/h} = 2\text{P/min}$ so 1 minute 2 pulses

10 minutes 20 pulses OK

Use 1k h/P, then $12\text{P/h} = 0.2\text{P/min}$, so no pulses in 1 minute

10 minutes 2 pulses OK

Use 10k h/P, then $12\text{P/h} = 0.2\text{P/min}$, so 1 minute no pulses

10 minutes no pulse NG

- ⑤ Pulse units should reach 0.1kWh/P.

- 10kWh/P is NG.

- 1kWh/P usage rate is the lowest, there might not be any pulses in 10 minutes, causing a calculation error.

(c) Largest gas pulse input value

Gas amount pulse unit	0.01m ³ /P	0.05m ³ /P	0.1m ³ /P	0.5m ³ /P
Largest measurable flow volume	4,320m ³ /B	21,600m ³ /B	4,3200m ³ /B	21,6000m ³ /B
	180m ³ /h	900m ³ /h	1,800m ³ /h	9,000m ³ /h

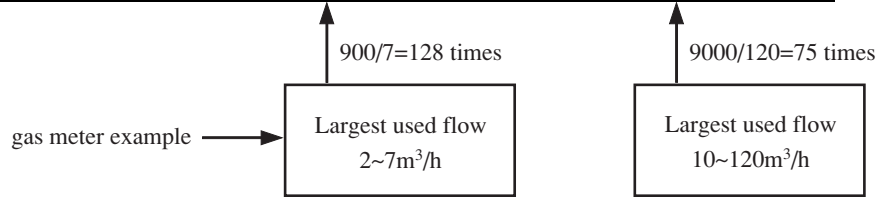

0.05m³/P time: If you use 2m³/h 40 pulse/h
 If you use 3m³/h 60 pulse/h
 If you use 5m³/h 100 pulse/h
 If you use 7m³/h 140 pulse/h

0.5m³/P time: If you use 10m³/h 20 pulse/h
 If you use 15m³/h 30 pulse/h
 If you use 30m³/h 60 pulse/h
 If you use 50m³/h 100 pulse/h
 If you use 90m³/h 180 pulse/h
 If you use 120m³/h 240 pulse/h

(d) Largest electric pulse input value

Gas amount pulse unit	0.01kWh/P	0.1kWh/P	1kWh/P	10kWh/P
Largest measurable flow volume	4,320kWh/B	43,200kWh/B	432,000kWh/B	4320,000kWh/B
	180kWh/h	1,800kWh/h	18,000kWh/h	180,000kWh/h

Note (1) Electricity meter pulse unit, please select 10kWh/P or less.

(Example) using 3 phase 200V– 30A electric meters, power rate at 100%, largest flow will be 30A

$$\text{Electricity consumption} = \sqrt{3} \times 200 \times 30 \times 1.0 = 10,392 \text{ kWh}$$

This time, set to 0.1kWh/P, so 103,920P/h = 1730 pluse/minute NG

Set to 1.0kWh/P, so 10,392P/h = 173 pluse/minute OK

Set to 10.0kWh/P, so 1,039P/h = 17.3 pluse/minute OK



Air-Conditioning & Refrigeration Systems Headquarters
16-5, 2-chome, Kounan, Minato-ku, Tokyo, 108-8215, Japan
Fax : (03) 6716-5926