

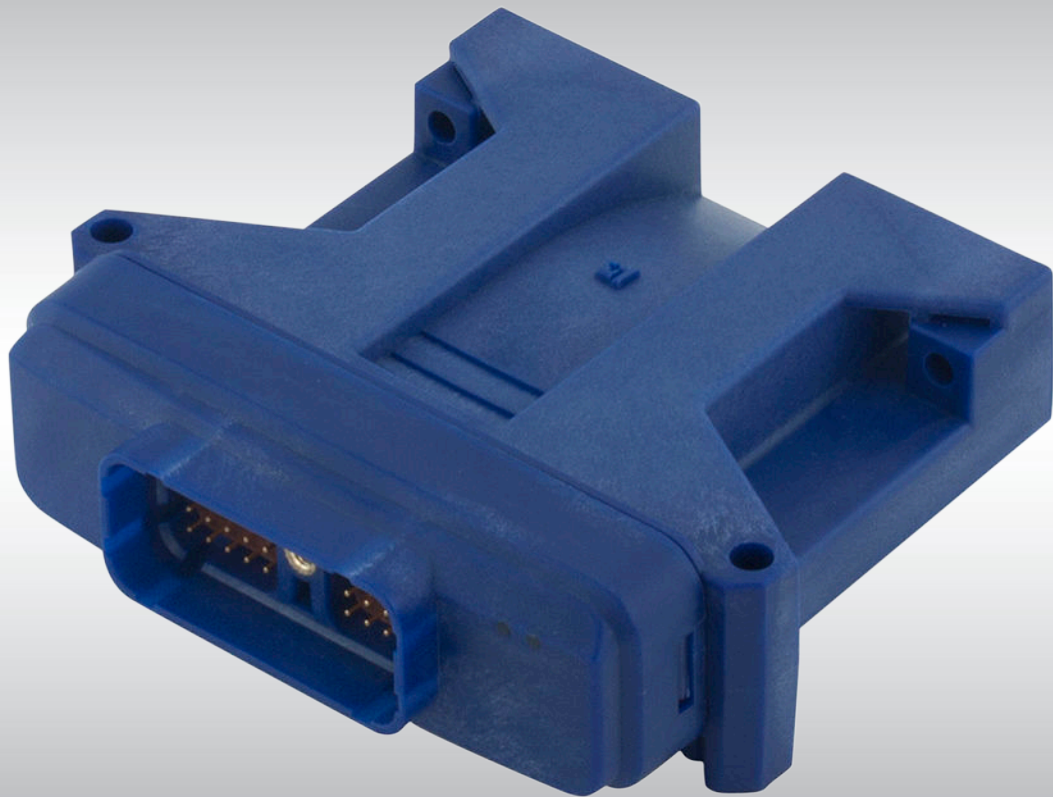

Safety Manual

PLUS+1<sup>®</sup> SC Controller

**SC0XX-1XX Controller Family**



**Revision history***Table of revisions*

<b>Date</b>	<b>Changed</b>	<b>Rev</b>
December 2014	First edition	AA

**Contents**

**Introduction**

This safety manual.....4  
 Certified SIL 2 Capable.....4  
 Reference manuals.....4  
 Model-specific API and data sheets.....4  
 Latest version of technical literature.....5  
 PLUS+1® SC Controller support.....5

**Component description and failure rates**

Processors and subsystems.....6  
 FMEDA analysis.....6  
 Failure categories description.....7  
 PLUS+1® SC Controller failure rates.....8  
 Recommended diagnostics.....8

**Design considerations**

Safety critical function.....9  
 Recommended diagnostics.....9  
 User application software development requirements.....10  
 User application software development requirements (continued).....11  
 Environmental limits.....11  
 Application limits.....11  
 Design verification.....11  
 SIL capability.....12  
 Systematic capability.....12  
 Random capability.....12  
 Connection of the PLUS+1® SC Controller to sensors and actuators .....12  
 Requirements.....12

**Installation and operation considerations**

Installation.....13  
 Physical location and placement .....13  
 Repair and replacement .....13  
 Useful life.....13  
 Software/hardware version numbers.....13  
 Security considerations.....13  
 Danfoss Power Solutions notification .....13

**Using the FMEDA results**

PFH calculation or PFD<sub>AVG</sub> calculation PLUS+1® SC Controller .....14  
 Example application, failure rate analysis.....14

**Abbreviations and definitions**

Abbreviations.....15  
 Definitions.....15

Introduction

This safety manual

This safety manual provides information necessary to design, implement, verify and maintain a safety critical function utilizing the PLUS+1® SC Controller. This manual provides necessary requirements for meeting the IEC 61508 functional safety standard.

**Warning**

Read manual completely before programming your application.

**Certified SIL 2 Capable**

The SC0XX-1XX Controller Family is certified SIL 2 Capable when deployed with the certified SIL 2 Capable OS that is embedded in their respective SC0XX-1XX HWD files.

The SC0XX-0XX Controller Family is designed for meeting the needs of SIL 2 applications where the OEM certifies at the machine level. The SC0XX-0XX Controller Family is not certified SIL 2 Capable as a component regardless of the HWD files with which it is deployed. The table below summarizes this information (the HWD filenames are representative, but not actual).

In all cases, the OEM/customer is responsible for the safety integrity requirement, implementation, and validation of their application.

Controller Family	HWD for the Primary Processor	HWD for the Secondary Processor	Component-Level SIL 2 Capable	Machine-Level SIL 2 Capable
SC0XX-1XX	SC0XX-1XX_HWD_Primary*	SC0XX-1XX_HWD_Secondary*	Yes	Yes
SC0XX-1XX	SC0XX-0XX_HWD_Primary	SC0XX-0XX_HWD_Secondary	No	Yes
SC0XX-0XX	SC0XX-1XX_HWD_Primary*	SC0XX-1XX_HWD_Secondary*	No	Yes
SC0XX-0XX	SC0XX-0XX_HWD_Primary	SC0XX-0XX_HWD_Secondary	No	Yes

\*These HWD files incorporate the certified SIL 2 Capable OS with Safety Diagnostic Functions.

**Reference manuals**

Manual

Title	Type	Identification number
PLUS+1® SC0XX-1XX Controller Family	Technical Information	L1415500
PLUS+1® GUIDE Software User Manual	Operation Manual	10100824
How to Install PLUS+1® GUIDE Upgrades	Operation Manual	11078040

**Model-specific API and data sheets**

API and data sheet

SC Controller model	Literature identification number		
	Primary processor HW description—API	Secondary processor HW description—API	Data Sheet
SC050-120/122	70156324	70156321	L1410421
SC024-120/122	70156499	70156500	L1410171
SC024-110/112	70156496	70156498	L1410890
SC050-13H	70153891	70153903	L1407546

**Introduction****Latest version of technical literature**

---

Danfoss product literature is online at: <http://powersolutions.danfoss.com/literature/>

---

**PLUS+1° SC Controller support**

Contact information is online at: <http://powersolutions.danfoss.com/products/PLUS-1-GUIDE/PLUS-1-support-and-training/>

Component description and failure rates

Processors and subsystems

The PLUS+1® SC Controller contains two processors, the primary and the secondary processor, which communicate asynchronously with each other. The PLUS+1® SC Controller has six main subsystems, each of which was analyzed individually. The configuration of a specific controller deployment is a function of the user application software.

Analyzed subsystems

Subsystem	Description
Common Logic	Electrical components and circuitry typically involved with all applications regardless of the input-output channel configuration
DIN/AIN/FreqIN	Digital analog and frequency input pins
CrntIn (current)	Current input pins
ResIN	Resistance input pins
DOUT	Digital output pins
CrntOUT (current)	Current output pins

FMEDA analysis

The FMEDA analysis results include the elements shown in the following diagram (components and inputs/outputs are color coded, blue for the primary processor and red for the secondary processor).

PLUS+1 SC Controller—Parts included in the FMEDA

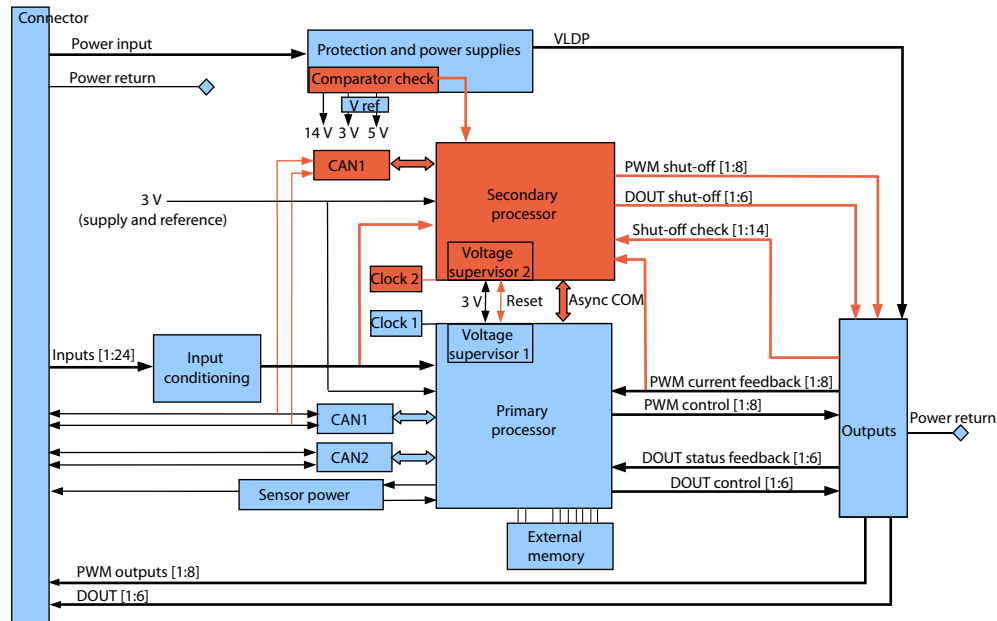

The PLUS+1® SC Controller is classified as a Type B<sup>1</sup> high demand mode component in accordance to IEC 61508. The hardware fault tolerance is a function of the system architecture which will vary by application.

The PLUS+1® SC Controller is certified to provide a 1oo1D architecture in accordance with IEC 61508. This allows the conclusion that a CAT2 architecture, in accordance with ISO 13849 or ISO 25119 can be implemented. For example this can be accomplished by using the primary processor as main controller for the Safety Function and the secondary processor as diagnostic element (intelligent watch dog, TE-

<sup>1</sup> Type B component: “Complex” element (using microcontrollers or programmable logic); for details see 7.4.4.1.3 of IEC 61508.

**Component description and failure rates**

Test Equipment) to observe the correct function of the primary processor and to de-energize (safe-state) independently all corresponding safety-related outputs.

Detailed analysis, review and documentation for compliance to ISO 13849 or ISO 25119 has to be done by the designer or integrator of the safety related system.

**Failure categories description**

In order to judge the failure behavior of the PLUS+1® SC Controller, the following definitions for the failure of the component apply.

*Definitions for failure of the component*

Failure category <sup>(1)</sup>	Definition
Fail-Safe State	State where the safety output is de-energized.
Fail Safe	State where the safety output is de-energized.
Fail Detected	Failure that is detected by the PLUS+1® SC Controller and causes the output signal to go to the predefined fail safe state.
Fail Dangerous	Failure that deviates the measured input state or the actual output by more than the safety accuracy (2% of span) and that leaves the output within the active range.
Fail Dangerous Undetected	Failure that is dangerous and that is not being diagnosed by automatic diagnostics or expected user logic.
Fail Dangerous Detected	Failure that is dangerous but is detected by automatic diagnostics or is expected to be detected by user logic.
Fail High <sup>(2)(3)</sup>	Failure that causes a safety input signal to go to a value that is clearly above the normal range and can therefore be reliably detected by the user application software.
Fail Low <sup>(2)(3)</sup>	Failure that causes a safety input signal to go to a value that is clearly below the normal range and can therefore be reliably detected by the user application software.
No Effect	Failure of a component that is part of the safety function but that has no effect on the safety function.
Annunciation Detected	Failure that does not directly impact safety but does impact the ability to detect a future fault (such as a fault in a diagnostic circuit) and that is detected by internal diagnostics.
Annunciation Undetected	Failure that does not directly impact safety but does impact the ability to detect a future fault (such as a fault in a diagnostic circuit) that is not detected by internal diagnostics.
$\lambda_{SD}$	Failure rate of all safe detected failures
$\lambda_{SU}$	Failure rate of all safe undetected failures
$\lambda_{DD}$	Failure rate of all dangerous detected failures
$\lambda_{DU}$	Failure rate of all dangerous undetected failures
$\lambda_D$	Failure rate of all dangerous failures, detected and undetected
$A_D$	Failure rate of all annunciation detected failures
$A_U$	Failure rate of all annunciation undetected failures
FIT	Failure In Time ( $1 \times 10^{-9}$ failures per hour)

<sup>(1)</sup> The failure categories listed above, expand upon the categories listed in IEC 61508, which are only safe and dangerous, both detected and undetected. In IEC 61508, the No Effect failures cannot contribute to the failure rate of the safety function. Therefore, they are not used for the Safe Failure Fraction calculation.

<sup>(2)</sup> Depending on the application, a Fail High or a Fail Low failure can either be safe or dangerous and may be detected or undetected depending on the user software application program.

<sup>(3)</sup> Consequently, during a Safety Integrity Level (SIL) verification assessment, the Fail High and Fail Low failure categories need to be classified as safe or dangerous, and as detected or undetected.

**Component description and failure rates**
**PLUS+1® SC Controller failure rates**

The results of the FMEDA analysis for the PLUS+1® SC Controller are presented in the following table.

*Failure rates (FIT)*

<b>Controller Subsystem</b>	$\lambda_{SD}$	$\lambda_{SU}$	$\lambda_{DD}$	$\lambda_{DU}$
Common Logic	2451	16	2556	263
DIN/AIN/FreqIN	0	11	0	22
CrntIn (current)	0	5	0	5
ResIN	0	11	0	11
DOUT	73	38	28	1
CrntOUT (current)	143	1	36	10

**Recommended diagnostics**

The PLUS+1® SC Controller can be implemented with diagnostics to detect many dangerous failures and other failures that would result in the controller operating in a degraded mode. The machine integrator is responsible for the safety and compliance to relevant standards. See [Safety critical function](#) on page 9 for design considerations and diagnostics recommendations.



**Design considerations**
**Safety critical function**

The PLUS+1® SC Controller can perform a wide variety of control functions. If these control functions of the primary processor are safety critical, then additional safety reliability can be achieved by configuring the secondary processor to monitor the sensor inputs, perform diagnostics, and act to bring the machine to a safe state if safe operating parameters are violated. The recommended configuration is to use the secondary processor to monitor the control function of the primary processor.

**Recommended diagnostics**

The following table lists recommended diagnostics. These diagnostics are implemented in the user application software that would be loaded into the PLUS+1® SC Controller.

**Warning**

If these diagnostics are not implemented, then all dangerous failures should be treated as dangerous undetected failures.

*Diagnostics*

Function	Failure mode	Condition	Action	Continuous or Start-up
Sensor power	Short to battery	Analog reading at or near maximum	Stop reading inputs powered by sensor power.	Continuous
Sensor power	Short to ground	Analog reading at or near zero	Stop reading inputs powered by sensor power.	Continuous
Sensor power	Out of range	Analog reading different than expected	Can compensate inputs for new voltage if possible	Continuous
Analog input	At Max	Analog reading at or near max	Stop using this input	Continuous
Analog input	At zero volts	Analog reading at or near zero	Stop using this input	Continuous
Current driver	Load shorted	Duty cycle at least 50% less than expected for known load	Information only or turn off output	Continuous
Current driver	Load shorted	Status signal indicates short circuit	Turn off output immediately	Continuous
Current driver	Open load	Duty cycle at least 50% less than expected for known load	Information only or turn off output	Start-up
Current driver	Incorrect load	Coil resistance is greatly different than expected	Do not use that output	Continuous
Digital input	Load shorted	Status signal indicates short circuit or open load	Application dependent	Continuous
Digital input	Open load	Status signal indicates short circuit or open load	Application dependent	Continuous
Battery Power	Dangerously High	Battery voltage reading above 36V	Turn off all outputs and ignore inputs	Continuous
Battery Power	Dangerously Low	Battery voltage reading below 7V	Turn off all PWM outputs	Continuous
Frequency input	Open	Analog reading is at or near middle voltage	Ignore frequency input	Continuous
Frequency input	No signal	Analog value doesn't change for longer than the maximum period	Ignore frequency input	Continuous

Design considerations

Diagnostics (continued)

Function	Failure mode	Condition	Action	Continuous or Start-up
CAN	Bus off	CAN bus status signal indicates bus off	Turn off outputs that rely on CAN information	Continuous
CAN	Time out	An expected message hasn't been received in the expected time	Turn off outputs that rely on that message	Continuous
CAN	Failed transition	Application requests message transmission while pending flag is active	Application dependent	Continuous
Configuration	Invalid configuration	Status signal indicates input or output is configured in an invalid way.	Make change to application software	Start-up

User application software development requirements

 **Warning**

The application programmer must apply these software development requirements when developing their safety-related system to insure the most robust safety integrity of the system architecture.

- CAN bus must not be used for safety critical functions, unless CAN-BE-SAFE protocol/product from Danfoss is deployed.
- All changes made to the configuration through the service tool must be verified by the user to ensure that they function as expected in the safety controller.
- The system must be designed with de-energized as the safe state.
- Appropriate action must be taken to put the system into a safe state when an output to output-feedback mismatch error is identified by the application.
- The user application software must include plausibility checks on frequency input data to detect possible failures in frequency input calculations.
- EEPROM data must include software part number and the user application software should check that this matches with the application.
- The user application software must include plausibility checks on all safety relevant inputs.
- If data is shared between the primary and secondary processors through the internal UART, time monitoring must be used to ensure that messages are being sent within the expected time period.
- The user application software must take appropriate action to put the system into a safe state when a current feedback reading mismatch is reported.
- If the user application allows it, the current output must periodically be set to zero to allow the zero offset to be recalculated.
- For optimal performance, the output current should be set to zero after large temperature changes (> 25° C (77° F)) to allow the zero offset to be re-calculated
- If the checksum on the EEPROM fails, the user application software must shutdown outputs (de-energize) depending on the EEPROM data or use default data if that can be done safely.
- Redundant channels must be utilized to provide reliability where there is concern about channel reliability based on PFH.
- Signal comparisons must be implemented by the user application software to compare signals between primary and secondary processors for safety related signals. Function blocks from the Safety Library can help with this task.
- Wiring of the control must be done in compliance with the Danfoss wiring guidelines addressed in *PLUS+1° SC0XX-1XX Controller Family Technical Information*, **L1415500**.
- The user application software must implement strategies to mitigate against the effects of corrupted RAM. For example, include shadow copies of safety critical data and checksums of data.
- Internal UART communication implemented by user application software must have as a minimum control mechanism of a heartbeat with sequence signal.

## Design considerations

### User application software development requirements (continued)

#### Warning

The application programmer must apply these software development requirements when developing their safety-related system to insure the most robust safety integrity of the system architecture.

- In all cases, the sensor power supply must be monitored and taken into a ratiometric calculation for the analog inputs.
- The user application software must implement shutdown of safety critical outputs either by the primary or the secondary processor or by both processors based on user application software requirements.
- The user application software must be tested for proper function including fault insertion testing. For more details, see the topic *Software Safety Validation* and the chapter *Risk Reduction* in the *PLUS+1° GUIDE User Manual, 10100824*.
- The user application software must be tested for proper response to:
  - Highest frequency input conditions.
  - Highest frequency output conditions.
  - Highest CAN traffic load conditions on the corresponding used CAN buses.
- The user application software must verify that the OSExecTimeout can meet the process safety time.
- The OS.ChecksumFailureTreatment parameter allows the user application software to override memory corruption faults and to continue operation instead of turning off all outputs. The user application software must not override faults, since doing so could result in an unsafe condition.
- The user application software must verify that either the primary or the secondary processors or both processors are capable of disabling the safety related outputs.
- The user application software must use the frequency values and the count value of the Quad encoder inputs to validate functionality.
- The user application software must verify that the current output overload status returns to zero after commanding zero current output.
- A Functional Safety Assessment must be conducted before designing any safety related system using the PLUS+1° SC Controller.

## Environmental limits

The designer or integrator of a safety critical function must verify that the safety controller is rated for use within the expected environmental limits of the target application. Refer to [Model-specific API and data sheets](#) on page 4 for the model-specific PLUS+1° SC Controller Data Sheet, for environmental limits.

## Application limits

The designer or integrator of a safety critical function must check that the safety controller is rated for use within the expected application limits. Refer to the *PLUS+1° SC0XX-1XX Controller Technical Information, L1415500*, for safety controller limits.

## Design verification

Refer to [PLUS+1 SC Controller failure rates](#) on page 8 for a summary of failure rates for the PLUS+1° SC Controller.

The achieved Safety Integrity Level (SIL) of an entire Safety Critical Function design must be verified by the designer or integrator via a calculation of PFH considering the I/O required, demand mode, any implemented diagnostics, safety time, and architecture.

The failure rate data listed the FMEDA report is only valid for the useful lifetime of a PLUS+1° SC Controller. The failure rates will increase sometime after this useful lifetime period. Reliability calculations based on the data listed in the FMEDA report for mission times beyond the lifetime may yield results that are too optimistic, in other words, the calculated Safety Integrity Level will not be achieved.

## Design considerations

### SIL capability

#### Systematic capability

The systematic capability of the PLUS+1° SC0XX-1XX Controller Family is SC 2 per IEC 61508.

#### Random capability

Refer to [PLUS+1 SC Controller failure rates](#) on page 8 for a summary of failure rates for the PLUS+1° SC Controller.

For each user application, the failure rates for the particular configuration should be determined and compared to the allowable failure rate for a given SIL target.

### Connection of the PLUS+1° SC Controller to sensors and actuators

The connection of the PLUS+1° SC Controller to the required sensors and actuators must be performed in accordance with the *PLUS+1° SC0XX-1XX Controller Family Technical Information, L1415500*.

### Requirements

- The system's response time must be less than the process safety time defined by the user application.
- The worst-case response time for a change of value of an analog input or contact signal (measured at the terminals) through the complete system to the completion of change of state of the analog output or contact output (measured at the terminals) will be a maximum of 10 ms plus the user application software programmed ExecTimeout, as measured to the standard outputs. This worst case time must be determined for the worst-case loading of the safety controller. See [Model-specific API and data sheets](#) on page 4.
- The diagnostic self-checks other than the RAM diagnostic self-test and CRC on Flash application must be performed based on demand every loop time, the delay time from the onset of a failure to the time at which the outputs reach the safe state will be a maximum of 10 ms plus the user application software program parameter, ExecTimeout.
- The time interval of RAM diagnostic self-check for the platform is a maximum of 1 hour. The time interval RAM test is reported to the user application software.
- The CRC flash check time for the user application software is a maximum of 1 hour and is reported to the user application software.

#### *Diagnostics and response times*

Description	Worst case time	Additional information
Diagnostics and Response Times	1 hour	Depends on total size of RAM
Flash CRC error detect from onset to safe state	1 hour	Depends on total size of Flash memory
Change of input to output	10 ms	Not including ExecTimeout
Diagnostic error detection time from onset to safe state	10 ms	Diagnostics are based on demand during execution loop

- The maximum delay time from the onset of a failure to the time at which the outputs reach the safe state is the diagnostic time interval plus 10 ms.
- All safety related system components, including the PLUS+1° SC Controller, must be operational before machine operation.
- Personnel must verify that the PLUS+1° SC Controller is suitable for use in safety applications by confirming the PLUS+1° SC Controller's nameplate is properly marked.
- Personnel performing testing on the PLUS+1° SC Controller must be competent to perform such testing. Functional Safety Training is provided by Danfoss Power Solutions, and details can be found on the Danfoss Power Solutions website at: <http://powersolutions.danfoss.com/solutions/Functional-safety/>.
- Results from the functional tests and diagnostics must be recorded and reviewed periodically.

## Installation and operation considerations

### Installation

The PLUS+1® SC Controller must be installed per standard practices outlined in the *PLUS+1® SC0XX-1XX Controller Family Technical Information, L1415500*. The environment must be checked to verify that environmental conditions do not exceed the ratings. Instructions on installation of latest version of the safety controller HWD file are found in *How to Install PLUS+1® GUIDE Upgrades Operation Manual, 11078040*.

### Physical location and placement

The PLUS+1® SC Controller must be mounted in accordance with the *PLUS+1® SC0XX-1XX Controller Family Technical Information, L1415500*, in a low vibration environment. If excessive vibration is expected, special precautions must be taken to ensure the integrity of electrical connections or the vibration should be reduced using appropriate damping mounts.

### Repair and replacement

The PLUS+1® SC Controllers are not repairable and no maintenance of them is required.

### Useful life

The useful life of the PLUS+1® SC Controller is 30 years. No proof tests are required.

### Software/hardware version numbers

See the Application Interface Document for the relevant PLUS+1® SC Controller, *Model-specific API and data sheets* on page 4.

### Security considerations

The PLUS+1® SC Controller does not use data that the user can configure externally, for example, by the PLUS+1 Service Tool. The user application software may contain data that is configured externally. If this is the case, then suitable security should be provided. The PLUS+1® GUIDE Software User Manual, **10100824** provides a description of how to handle parameters in a safe way.

### Danfoss Power Solutions notification

Any failures that are detected and that compromise functional safety should be immediately reported to Danfoss Power Solutions. Any change suggestions for future improvements or new features can be forwarded to Danfoss Power Solutions:

Contact information is online at: <http://powersolutions.danfoss.com/products/PLUS-1-GUIDE/PLUS-1-support-and-training/>

Using the FMEDA results

**PFH calculation or PFD<sub>AVG</sub> calculation PLUS+1° SC Controller**

An average Probability of Failure per Hour (PFH) or an average Probability of Failure on Demand (PFD<sub>AVG</sub>), depending on the operating mode, must be determined for each Safety Critical Function. The total will include the failure rate of all sensors and actuators that are required to perform the function as well as the elements of the PLUS+1° SC Controller that are utilized.

Since the elements of the controller subsystem vary based on the Safety Critical Function implemented, the contribution for the PLUS+1° SC Controller needs to be determined for each application.

To demonstrate how to calculate the contribution of the PLUS+1° SC Controller, consider the example of a steering function that is safety critical. The steering function relies on a Steer Command that is transmitted by a joystick utilizing a single ResIN – Resistance Mode Input. The controller processes the input and controls the movement of the machine through a dual path control subsystem utilizing four CrntOUT outputs.

This safety critical function would have an overall failure rate that is the sum of controller subsystems used which are:

- (1) Common Logic
- (1) ResIN
- (4) CrntOUT (current)

In a machine application, the safety critical function could be operating in high demand. In a high demand function, only the dangerous undetected failures are included when calculating the PFH. To be considered a high demand application, the diagnostics must be executed 10 times faster than the process safety time. Care must be taken when modeling a function as high demand. It is recommended that the designer or integrator review the requirements with Danfoss Power Solutions to help avoid understating PFH.

**Example application, failure rate analysis**

The following table is for an example application. Consider for this example, the function is a high demand system.

*Failure rate analysis for the example function*

Controller Subsystem	Quantity	$\lambda_{SD}$	$\lambda_{SU}$	$\lambda_{DD}$	$\lambda_{DU}$	Total $\lambda_D$
Common Logic	1	2451	16	2556	263	2819
DIN/AIN/FreqIN	0	0	11	0	22	22
CrntIn (current)	0	0	5	0	5	5
ResIN	1	0	11	0	11	11
DOUT	0	73	38	28	1	29
CrntOUT (current)	4	143	1	36	10	46
Example Total (Sum of Quantity multiplied by Column Value)		3023	31	2700	314	3014

The implementation of the recommended diagnostics (Section 3.1) affects the system failure rate. For example, if all recommended diagnostics are implemented, only the undetected failures ( $\lambda_{DU}$ ) contribute to the failure rate, which is 314 FITS or  $3.14 \times 10^{-7}$  failures per hour. This results in a SFF of 94.8%, which is a SIL2 compliant system.

If none of the recommended diagnostics are implemented, then all failures ( $\lambda_{SD}$ ,  $\lambda_{DU}$ ,  $\lambda_{DD}$ ) are treated as undetected failures. In this example, the failure rate would then be 3014 FITS or  $3.014 \times 10^{-6}$  failures per hour, which does not meet the SIL2 requirement, but does meet the SIL1 requirements.

Abbreviations and definitions

Abbreviations

*Abbreviations*

Abbreviation	Definition
<b>EUC</b>	Equipment under control.
<b>FMEDA</b>	Failure modes, effects and diagnostic analysis.
<b>HFT</b>	Hardware fault tolerance.
<b>PFH</b>	Probability of failure per hour.
<b>PFD<sub>AVG</sub></b>	Average probability of failure on demand.
<b>SFF</b>	Safe failure fraction, summarizes the fraction of failures which lead to a safe state and the fraction of failures which will be detected by diagnostic measures and lead to a defined safety action.
<b>SIF</b>	Safety instrumented function.
<b>SIL</b>	Safety integrity level.
<b>SRS</b>	Safety related system, implementation of one or more safety critical functions. An SRS is composed of any combination of sensor(s), control module(s), and actuator(s).
<b>DIN/AIN/FreqIN</b>	Digital analog and frequency input pins.
<b>CrntIn (current)</b>	Current input pins.
<b>ResIN</b>	Resistance input pins.
<b>DOUT</b>	Digital output pins.
<b>CrntOUT (current)</b>	Current output pins.
<b>OS</b>	Operating system.

Definitions

*Definitions*

Term	Definition
Continuous Demand Mode	Mode where the safety function retains the equipment under control in a safe state as part of its normal operation.
High Demand Mode	Mode where the safety function is only performed on demand, in order to transfer the EUC into a specified safe state, and where the frequency of demands is greater than one per year.
Low Demand Mode	Mode where the safety function is only performed on demand, in order to transfer the EUC into a specified safe state, and where the frequency of demands is not greater than one per year. NOTE: The E/E/PE safety-related system that performs the safety function normally has no influence on the EUC or EUC control system until a demand arises. However, if the E/E/PE safety-related system fails in such a way that it is unable to carry out the safety function, then it may cause the EUC to move to a safe state (see 7.4.6 of IEC 61508).
Safety	Freedom from unacceptable risk of harm.
Functional Safety	The ability of a system to carry out the actions necessary to achieve or to maintain a defined safe state for the equipment, machinery, plant, and apparatus under control of the system.
Basic Safety	The equipment must be designed and manufactured such that it protects against risk of damage to persons by electrical shock and other hazards and against resulting fire and explosion. The protection must be effective under all conditions of the nominal operation and under single fault conditions.
Safety Assessment	The investigation to arrive at a judgment, <i>based on evidence</i> of the safety achieved by safety-related systems.
Safety Critical Function	A set of equipment intended to reduce the risk due to a specific hazard.

## Abbreviations and definitions

*Definitions (continued)*

<b>Term</b>	<b>Definition</b>
Process Safety Time	The period of time between a failure occurring in the control system (with the potential to give rise to a hazardous event) and the occurrence of the hazardous event if the safety function is not performed.
Type A Component	<i>Non-Complex</i> element (using discrete elements); for details see 7.4.4.1.2 of IEC 61508.
Type B Component	<i>Complex</i> element (using micro controllers or programmable logic); for details see 7.4.4.1.3 of IEC 61508.
Common Logic	Electrical components and circuitry typically involved with all applications regardless of the input-output channel configuration.











**Products we offer:**

- Bent Axis Motors
- Closed Circuit Axial Piston Pumps and Motors
- Displays
- Electrohydraulic Power Steering
- Electrohydraulics
- Hydraulic Power Steering
- Integrated Systems
- Joysticks and Control Handles
- Microcontrollers and Software
- Open Circuit Axial Piston Pumps
- Orbital Motors
- PLUS+1® GUIDE
- Proportional Valves
- Sensors
- Steering
- Transit Mixer Drives

**Danfoss Power Solutions** is a global manufacturer and supplier of high-quality hydraulic and electronic components. We specialize in providing state-of-the-art technology and solutions that excel in the harsh operating conditions of the mobile off-highway market. Building on our extensive applications expertise, we work closely with our customers to ensure exceptional performance for a broad range of off-highway vehicles.

We help OEMs around the world speed up system development, reduce costs and bring vehicles to market faster.

Danfoss – Your Strongest Partner in Mobile Hydraulics.

**Go to [www.powersolutions.danfoss.com](http://www.powersolutions.danfoss.com) for further product information.**

Wherever off-highway vehicles are at work, so is Danfoss. We offer expert worldwide support for our customers, ensuring the best possible solutions for outstanding performance. And with an extensive network of Global Service Partners, we also provide comprehensive global service for all of our components.

Please contact the Danfoss Power Solution representative nearest you.

**Comatrol**

[www.comatrol.com](http://www.comatrol.com)

**Schwarzmueller-Inverter**

[www.schwarzmueller-inverter.com](http://www.schwarzmueller-inverter.com)

**Turolla**

[www.turollaocg.com](http://www.turollaocg.com)

**Valmova**

[www.valmova.com](http://www.valmova.com)

**Hydro-Gear**

[www.hydro-gear.com](http://www.hydro-gear.com)

**Daikin-Sauer-Danfoss**

[www.daikin-sauer-danfoss.com](http://www.daikin-sauer-danfoss.com)

Local address:

**Danfoss Power Solutions (US) Company**  
2800 East 13th Street  
Ames, IA 50010, USA  
Phone: +1 515 239 6000

**Danfoss Power Solutions GmbH & Co. OHG**  
Krokamp 35  
D-24539 Neumünster, Germany  
Phone: +49 4321 871 0

**Danfoss Power Solutions ApS**  
Nordborgvej 81  
DK-6430 Nordborg, Denmark  
Phone: +45 7488 2222

**Danfoss Power Solutions (Shanghai) Co., Ltd.**  
Building #22, No. 1000 Jin Hai Rd  
Jin Qiao, Pudong New District  
Shanghai, China 201206  
Phone: +86 21 3418 5200

Danfoss can accept no responsibility for possible errors in catalogues, brochures and other printed material. Danfoss reserves the right to alter its products without notice. This also applies to products already on order provided that such alterations can be made without changes being necessary in specifications already agreed. All trademarks in this material are property of the respective companies. Danfoss and the Danfoss logotype are trademarks of Danfoss A/S. All rights reserved.