



**CN2HK LIMITED**

# **Single Door Access Controller System (CK-138-Mifare)**

---

## **User Manual**

Please read this manual before operating this product.

After you finish reading this manual, store it in a safe place for future reference.

**ENG**





## **FCC STATEMENT**



This equipment has been tested and found to comply with the limits for a Class B digital device, pursuant to part 15 of the FCC Rules. These limits are designed to provide reasonable protection against harmful interference in a residential installation. This equipment generates, uses and can radiate radio frequency energy and, if not installed and used in accordance with the instructions, may cause harmful interference to radio communications. However, there is no guarantee that interference will not occur in a particular installation. If this equipment does cause harmful interference to radio or television reception, which can be determined by turning the equipment off and on, the user is encouraged to try to correct the interference by one or more of the following measures:

- Reorient or relocate the receiving antenna.
- Increase the separation between the equipment and receiver.
- Connect the equipment into an outlet on a circuit different from that to which the receiver is connected.
- Consult the dealer or an experienced radio/ TV technician for help.

This device complies with part 15 of the FCC Rules. Operation is subject to the following two conditions:

- 1) This device may not cause harmful interference.
- 2) This device must accept any interference received, including interference that may cause undesired operation.

Any changes or modifications not expressly approved by the party responsible for compliance could void the user's authority to operate the equipment.

## **CE Mark Warning**



This is a class B product. In a domestic environment, this product may cause radio interference, in which case the user may be required to take adequate measures.

# **Index**

- 1. Product Description**
- 2. Product Specification**
- 3. Installation**
- 4. Connection Diagram**
- 5. Jumpers Instructions**
- 6. Programming**
- 7. User Operations**
- 8. Hardware Reset Procedure**

## **Appendix:**

- 1. LED & Buzzer**
- 2. Contents**

# 1. Product Description

This is single-door controller is a series of independent ones that are developed for the control of exits of office building, intellectual building, residential area, public channel of building, through which user can open door with respondent card, can open with pass code or can with both respondent card and pass code, then a simple door controller system solution program is made.

Comparing with similar products in the current market, our product CK138-Mifare has the following advantages:

- A.) High Security, supporting wrong password alarming, anti-breaking alarming, alarm signal output.
- B.) Memory Backup chip circuit design, programming is not required when replacing new unit, user / cards information can be retrieved easily
- C.) Easy Programming, adding new card / delete card with master password.

# 2. Product Specification

**working voltage: DC 12V**

**unlock current:  $\leq 1.5A$**

**static current:  $\leq 1A$**

**available card quantity: 800 pieces**

**Maximum card-read distance: 5cm**

**RF card type: Mifare 1 or compatible cards / Key rings**

**working temperature:  $-40^{\circ}C \sim 70^{\circ}C$**

**working moisture: 10%  $\sim$  90%**

**size: 117 $\times$ 117 $\times$ 21mm**

### 3. Installation

Unpack cross-screw that fixes faceplate and motherboard, then take off motherboard and get it assembled on side wall which is at the exit, with attention on vertical orientation.

Alert!!! Please ensure to switch off power before connecting lines and switch on power after all lines being connected well! Please be sure that power voltage is 12v and that anode& cathode are in place!

### 3. Connection Diagram

A.) If you have a specific power supply with timer control, please connect it as below diagram: (PLEASE set JUMPER J1 to “3-4” PUSH!!!!)

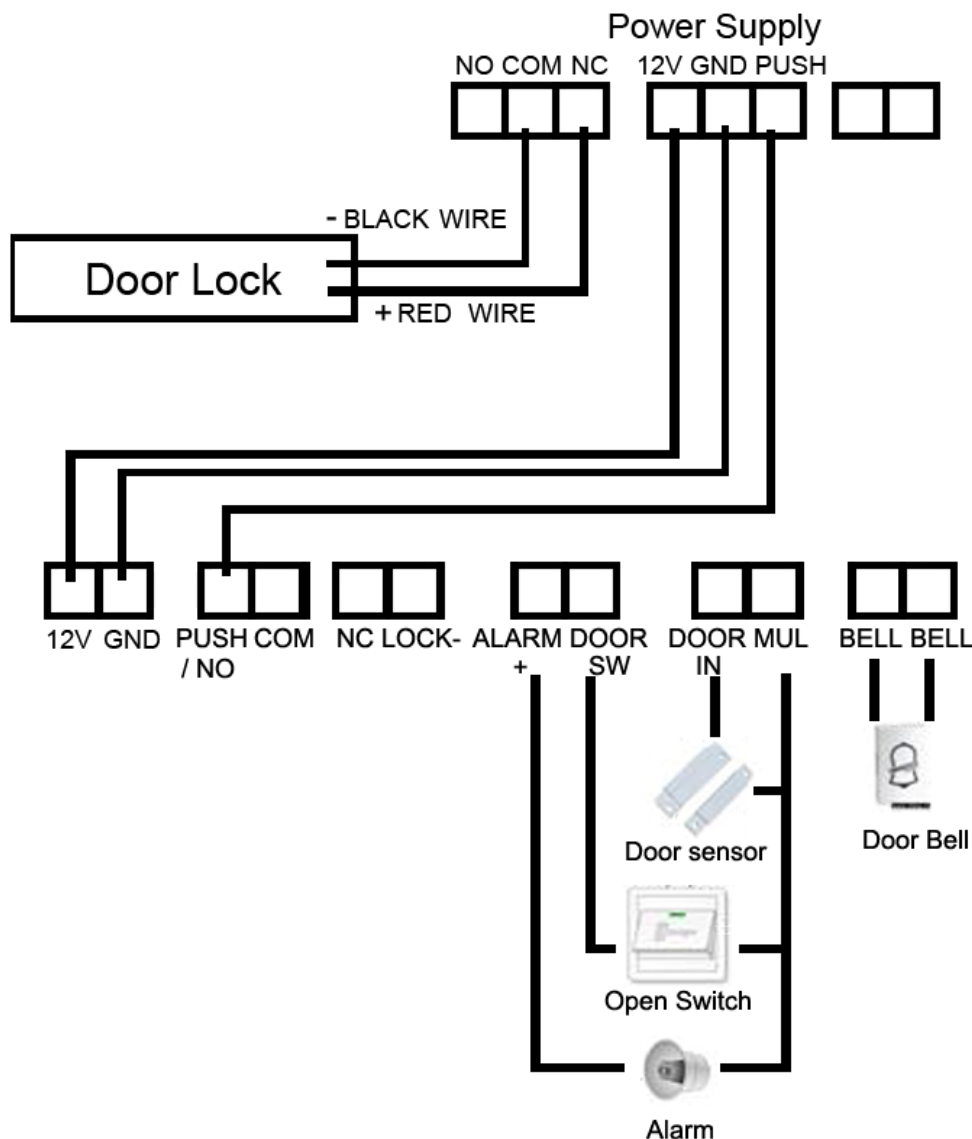

**B.) If you have normal DC 12V Power supply only, please connect it this way:  
(PLEASE set JUMPER J1 to “1-2” LOCK!!!!)**

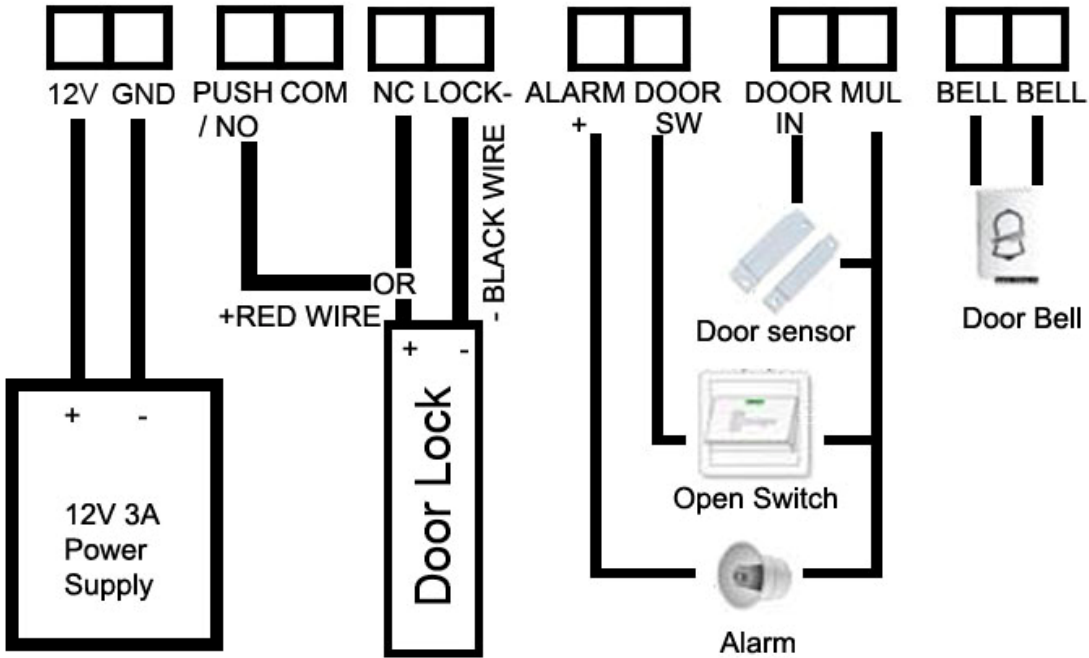

**C.) If you have normal DC 12V Power supply only, and want to use the controller as RELAY switch, (PLEASE set JUMPER J1 to “2-3”)**

**Connect the locking device to the COM & NC/NO**

## 4. Jumper Instructions

**Jumper “JP 1” Position:**

**A.) J1 set to “1-2 LOCK”**

“Connect the NO type lock to NO (12V+) & LOCK-“ OR

“Connect the NC type lock to NC (12V+) & LOCK-“

(to keep door controller work steadily, we do not suggest to connect electric lock directly with controller, please use specific power supply as 4A above)

**B.) J1 set to “3-4 PUSH” (Factory default setting)**

Connect the PUSH to specific power supply (PUSH)

**C.) J1 set to “2-3 RELAY”**

NO/NC & COM will act as relay switch, no current output.

# 5. Programming

Original management pass word is 12345 and user password is 8888.

## 1. Enter “programming mode”

push\*=>input management pass word=>push#

(e.g. push \*123456# )

## 2 Function setup(under “programming mode” circumstance)

### (1) Modify management password:

push 0=>input new management password =>push#=>

again input new management password =>push#

note: password is 4-8 digital number.

### (2) Add user card

push 1 =>read card => push 4 digit user defined ID => push # => push \*

e.g. ( push 1, read card, push 0001#\* )

note:

a.) “4 digit user defined ID” must be “0001” to “9999”, cannot be duplicated.

b.) If need add more than 1 card,

push 1 =>read 1<sup>st</sup> card => push 4 digit user defined ID

read 2<sup>nd</sup> card => read 3<sup>rd</sup> card => push # => push \*

e.g. ( push 1, read 1<sup>st</sup> card, push 0005, read 2<sup>nd</sup> card, read 3<sup>rd</sup> card, push #\* )

the 1<sup>st</sup> card will be 0005, 2<sup>nd</sup> card will be 0006, 3<sup>rd</sup> card will be 0007

c.)

### (3) 4 ways to delete user card

A. Delete all user card: push2=>push 0000=>push # => push \*

B. Delete the card read: push2=>read card=>push # => push \*

C. Delete more than 1 card read:

push2=>read 1<sup>st</sup> card=> read 2<sup>nd</sup> card=> read 3<sup>rd</sup> card=>push # => push \*

D. Delete lost card: push2=>push 4 digit user defined ID =>push # => push \*



**(4) Setup for open mode**

**A. Open with reading valid card: push 300 => push # => push \***

**B. Open with reading valid card and password: push 301 => push # => push \***

**C. Open with reading valid card or correct password: push 302 => push # => push \***

**note: original setup is 302 for reading valid card or input password to open door.**

**(5) Setup for open door time**

**Push 4 => X X => push # => push \***

**note: XX is during 00-99, measure unit is second and default value is 3**

**seconds, and 0 is added for less than 2 digitals.**

**(6) How to modify use password**

**push 5=>input 1 new password with 4 digit number =>push # => push \***

**=>again input 1 new password with 4 digit number =>push # => push \***

**to save**

**(7) Anti-breaking Mode**

**To Disable anti-breaking alarm mode: (factory default is disabled)**

**Push 600 => push # => push \***

**To Enable anti-breaking alarm mode:**

**Push 601 => push # => push \***

**(Please ensure the anti-breaking switch is properly setup)**

**(8) Monitor Door open status**

**To Disable monitor door open status: (factory default is disabled)**

**Push 700 => push # => push \***

**To Enable monitor door open status:**

**Push 701 => push # => push \***

**(please connect the door sensor to DOOR IN & MUL)**

- when this monitor is enabled, after the door open under authorization, if the door is not closed after 1 minute, the buzzer will make sound.**
- when this monitor is enabled,, if the door is opened by force (without card or password), it will make alarm output at ALARM port. Please use valid card to stop the alarm.**

## **(9) Wrong Password Alarming**

**To Disable wrong password alarming: (factory default is disabled)**

**Push 800 => push # => push \***

**To Enable wrong password alarming:**

**Push 801 => push # => push \***

- **when this Wrong Password Alarming is enabled, if invalid card or wrong password is tried for 10 times, it will make alarm output at ALARM port.**
- **when this monitor is enabled, if the door is opened normally by card or password, press “8” within 2 seconds after the lock open, it will make alarm output at ALARM port. (this can act as emergency help) Please use valid card to stop the alarm.**

## **6. User Operation**

**Open by card:**

**under normal working environment, door can be opened with 1 valid card.**

**Open by card and password:**

**door can be opened if correct password is input 10 seconds after card is read.**

**Open by password:**

**door can be opened by inputting user password.**

**Attention: the door controller supports 3 modes, opening by card, by password and by card and password**

## **7. Hardware Reset Procedure**

**Factory Reset procedure for door controller:**

- 1. switch off power and keep pushing RESET(holding it)**
- 2. switch on the power and press RESET for 3 seconds, then unhold it and reset procedure is completed.**

**Status: the door controller goes into working status with 1 sound of buzzer.**

**Note:**

- 1. This procedure only change system password to default programming password, 12345, and user password 8888, others remain the same.**
- 2. normally please don't use initialization back to default unless user forgets password.**

## Appendix 1: LED & Buzzer

Issue type	Red light	Green light	Buzzer
Normal working circumstance	glitter once per second		
read valid card/correct password, unlock		light	two short beep
open door and push button, then unlock		light	one short beep
wrong password	light		three short beep
invalid card	light		three short beep
entry valid button	light		one short beep
alert to prevent from unpacking	glitter		long beep
programming status	light	light	two short beep
entry correct programming code	light	glitter quickly	one short beep
entry wrong programming code	light		three short beep

## Appendix 2: Content

### Packing list:

Access controller

User manual

1 set

1 piece