

Ethernet

CFW500

User's Guide

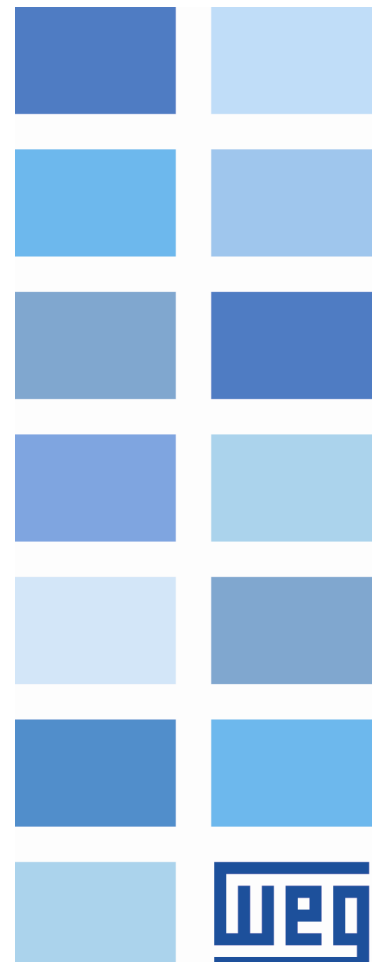



Ethernet User's Guide

Series: CFW500

Language: English

Document Number: 10003256290 / 00

Build 323

Publication Date: 12/2014

Contents

About the Manual	5
1 Equipment Characteristics in Ethernet Network	7
1.1 Modbus TCP specific characteristics	7
1.2 EtherNet/IP specific characteristics	7
1.3 PROFINET specific characteristics	7
2 Ethernet Overview	8
2.1 Ethernet Technology	8
3 Interfaces Description	9
3.1 Ethernet Plug-in Module	9
3.2 Connectors	9
3.3 Indication LEDs	9
4 Network Installation	11
4.1 IP Address	11
4.2 Communication Rate	11
4.3 Cable	11
4.4 Network Topology	12
4.5 Recommendations for Grounding Connection and Cable Routing	12
5 Parameterization	13
5.1 Symbols for the Properties Description	13
P0105 – 1st/2nd ramp selection	13
P0220 – Local/REMOTE Selection Source	13
P0221 – Speed Reference Selection – LOCAL Situation	13
P0222 – Speed Reference Selection – REMOTE Situation	13
P0223 – FORWARD/REVERSE Selection – LOCAL Situation	13
P0224 – Run/Stop Selection – LOCAL Situation	13
P0225 – JOG Selection – LOCAL Situation	13
P0226 – FORWARD/REVERSE Selection – REMOTE Situation	13
P0227 – Run/Stop Selection – REMOTE Situation	13
P0228 – JOG Selection – REMOTE Situation	13
P0313 – Action in Case of Communication Error (Fieldbus)	13
P0680 – Logical Status	14
P0681 – Motor Speed in 13 Bits	15
P0684 – Control Word	16
P0685 – Speed Reference	16
P0695 – Digital Outputs Setting	17
P0696 - Value 1 for Analog Outputs	18
P0697 - Value 2 for Analog Outputs	18
P0698 - Value 3 for Analog Outputs	18
P0800 – Ethernet Module Identification	18
P0801 – Ethernet Communication Status	19
P0803 – Ethernet Baud Rate	19
P0806 – Modbus TCP Watchdog	20
P0810 – IP Address Configuration	20

P0811 - IP Address 1	21
P0812 - IP Address 2	21
P0813 - IP Address 3	21
P0814 - IP Address 4	21
P0815 - Subnet CIDR	21
P0816 - Gateway 1	22
P0817 - Gateway 2	22
P0818 - Gateway 3	22
P0819 - Gateway 4	22
P0820 ... P0831 - Ethernet Read Words #3 ... #14	22
P0835 ... P0846 - Ethernet Write Words #3 ... #14	23
P0849 - Update Ethernet Configuration	24
6 Modbus TCP	25
6.1 Indication LEDs	25
6.2 Available Functions	25
6.3 Memory Map	25
6.3.1 Parameters	26
6.3.2 Memory Markers	26
6.4 Communication Errors	27
6.5 Startup Guide	27
6.5.1 Installing the Ethernet Module	27
6.5.2 Configuring the Drive	27
6.5.3 Configuring the Master	28
6.5.4 Communication Status	28
6.5.5 Operation Using Process Data	28
7 EtherNet/IP	29
7.1 Indication LEDs	29
7.2 Cyclic Data	29
7.3 Acyclic Data	29
7.4 EDS File	30
7.5 Modbus TCP Connections	30
7.6 Startup Guide	30
7.6.1 Installing the Ethernet Module	30
7.6.2 Configuring the Drive	30
7.6.3 Configuring the Master	31
7.6.4 Communication Status	31
7.6.5 Operation Using Process Data	31
8 PROFINET	32
8.1 Indication LEDs	32
8.2 Cyclic Data	32
8.3 Acyclic Data	32
8.4 XML File	33
8.5 Modbus TCP Connections	33
8.6 Startup Guide	33
8.6.1 Installing the Ethernet Module	33
8.6.2 Configuring the Drive	33



8.6.3	Configuring the Master	34
8.6.4	Communication Status	34
8.6.5	Operation Using Process Data	34
9	WEB Server	35
10	Faults and Alarms	36
	A0148/F0248 - Ethernet interface access error	36
	A0149/F0249 - Ethernet Offline	36

ABOUT THE MANUAL

This manual supplies the necessary information for the operation of the CFW500 frequency inverter using the Ethernet protocol. This manual must be used together with the CFW500 user's manual and programming manual.

1 EQUIPMENT CHARACTERISTICS IN ETHERNET NETWORK

Below are listed the main features for Ethernet communication module for CFW500 frequency inverter.

- There are 3 different plug-in modules, according to the specified communication protocol:
 - CFW500-CEMB-TCP: Modbus TCP protocol.
 - CFW500-CETH-IP: EtherNet/IP protocol.
 - CFW500-CEPN-IO: PROFINET IO protocol.
- It has an Ethernet communication port, according to the Fast Ethernet 100BASE-TX standard.
- The interface also makes available a Web server (HTTP).

1.1 MODBUS TCP SPECIFIC CHARACTERISTICS

- Operates as Modbus TCP server.
- The server provides up to 4 simultaneous Modbus TCP connections.
- Allows data communication for equipment operation and parameterization, as well as markers and data used for CFW500 ladder programming.

1.2 ETHERNET/IP SPECIFIC CHARACTERISTICS

- It is supplied with an EDS file for the network master configuration.
- Allows up to 14 input words and 14 output words for cyclic data communication.
- Acyclic data available for parameterization.

1.3 PROFINET SPECIFIC CHARACTERISTICS

- It is supplied with a XML file for the network master configuration.
- Allows up to 14 input words and 14 output words for cyclic data communication.
- Acyclic data available for parameterization.

2 ETHERNET OVERVIEW

Following it is presented general information about the Ethernet technology.

2.1 ETHERNET TECHNOLOGY

Ethernet is a technology for interconnecting local area networks (LAN) based on frames forwarding. It defines wiring and electrical signals for the physical layer, the frame format and protocol for media access control layer (MAC) of the OSI model.

Ethernet, however, mainly defines the physical medium and the frame format. Based on Ethernet, multiple protocols and higher-level services were specified and developed in order to perform desired activities over a network, such as packet routing, connection establishment, sending and receiving files, etc. Several of these protocols have also been widely disseminated and employed, such as IP, TCP, UDP, FTP, HTTP.

Widely used to interconnect computers in the office environment, the Ethernet technology also started being used in industrial environments for interconnection of field devices. For industrial environment also emerged different communication protocols based on Ethernet, among which we can mention Modbus TCP, EtherNet/IP, PROFINET.

3 INTERFACES DESCRIPTION

The CFW500 frequency inverter uses the plug-in module to provide a Ethernet interface for communication.

3.1 ETHERNET PLUG-IN MODULE



- Supplied items:
 - Installation guide.
 - Ethernet plug-in module.



NOTE!

There are 3 different plug-in modules, according to the specified communication protocol:

- CFW500-CEMB-TCP: Modbus TCP protocol.
- CFW500-CETH-IP: EtherNet/IP protocol.
- CFW500-CEPN-IO: PROFINET IO protocol.

It is important to use the plug-in model according to the desired protocol for application.

3.2 CONNECTORS

The accessory for Ethernet communication has an RJ45 connector for network connection. The connector pin out follows the Fast Ethernet 100BASE-TX standard, using two pairs of cables for data transmission and reception.

The accessory has a screw connector to connect the protective earth to the product. To improve noise immunity, it is recommended to link the protective earth via this connector. The Ethernet connector housing, usually connected to the cable shield, makes the connection to the protective earth via an RC circuit.

3.3 INDICATION LEDS

The Ethernet accessory has an LED indicator on the Ethernet port, and two bi-color status LEDs. These LEDs have the following functions and indications:

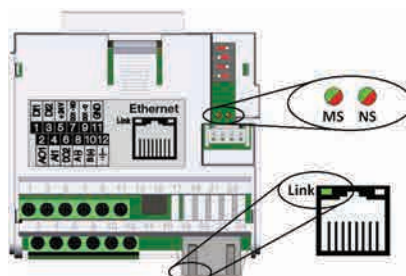

Figure 3.1: Ethernet Connectors and LEDs

Table 3.1: Ethernet Indication LEDs

LED	Color	Function
Link	Green	LED for link and activity indication.
Module Status (MS)	Bicolor (Green/Red)	Has a different behavior depending on the communication protocol, which is described in the section for each protocol.
Network Status (NS)	Bicolor (Green/Red)	Has a different behavior depending on the communication protocol, which is described in the section for each protocol.

NOTE!

During initialization, a test sequence is performed with MS and NS LEDs.

Table 3.2: LED Link

State	Description
Off	No link or powered off.
Green, solid	Link up, no activity.
Green, flashing	Link up and activity.

4 NETWORK INSTALLATION

This chapter presents recommendations related to equipment installation in an Ethernet network.

4.1 IP ADDRESS

Every equipment in an Ethernet network needs an IP address and subnet mask.

The IP addressing is unique in the network, and each equipment must have a different IP. The subnet mask is used to define which IP address range is valid in the network.

The CFW500 frequency inverter allows the use of two methods for programming these features, programmable via P0810:

- DHCP: enable the configuration of the CFW500 via DHCP server. The DHCP can automatically assign IP addresses, subnet mask, etc. to the devices on the network. The configurations performed via parameters are disregarded.
- Parameters: uses the configurations of IP address, mask and gateway as programmed on equipment parameters.



NOTE!

After changing these properties, for the changes to take effect, the equipment must be turned off and on again, or requesting the Ethernet settings update via P0849.

4.2 COMMUNICATION RATE

The Ethernet interfaces of the CFW500 frequency inverter can communicate using the 10 or 100 Mbps rates in half or full duplex mode.

The baud rate is programmed at P0803.



NOTE!

It is important that, for each Ethernet connection made between two points, the baud rate and the duplex mode are set to the same option. If the option AUTO is used in one of the points, you must set the other point also to AUTO, or to half duplex mode.

4.3 CABLE

Recommended characteristics for the cable:

- Standard Ethernet cable, 100Base-TX (FastEthernet), CAT 5e or higher.
- Shielded cable.
- Maximum length between devices: 100m.

For installation, it is recommended the use of shielded Ethernet cables specific for use in industrial environment.

4.4 NETWORK TOPOLOGY

To connect CFW500 frequency inverter in an Ethernet network, usually the star connection is made using an industrial switch.

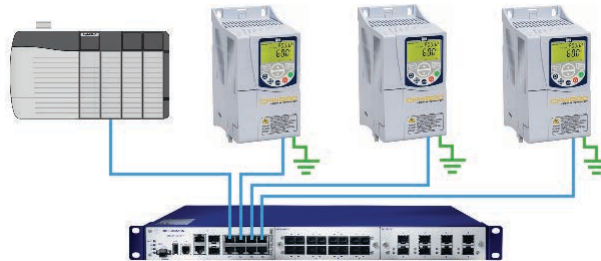

Figure 4.1: Ethernet network topology for CFW500

4.5 RECOMMENDATIONS FOR GROUNDING CONNECTION AND CABLE ROUTING

The correct connection with the ground decreases problems caused by interference in an industrial environment. The following are some recommendations about grounding and cable routing:

- Always use shielded twisted pair Ethernet cables and connectors with metallic housing.
- Connect the equipment grounding via grounding terminal. Avoid the cable connection on multiple grounding points, especially where there are grounds with different potentials.
- Pass signal cables and communication cables in dedicated pathways. Prevent laying these cables next to power cables.

5 PARAMETERIZATION

Next, the CFW500 frequency inverter parameters related to the Ethernet communication will be presented.

5.1 SYMBOLS FOR THE PROPERTIES DESCRIPTION

- **RO** Read-only parameter
- **RW** Read/write parameter
- **CFG** Parameter that can be changed only with motor stopped.
- **ETH** Parameter visible on the HMI if the product has the Ethernet interface installed

P0105 – 1ST/2ND RAMP SELECTION

P0220 – LOCAL/REMOTE SELECTION SOURCE

P0221 – SPEED REFERENCE SELECTION – LOCAL SITUATION

P0222 – SPEED REFERENCE SELECTION – REMOTE SITUATION

P0223 – FORWARD/REVERSE SELECTION – LOCAL SITUATION

P0224 – RUN/STOP SELECTION – LOCAL SITUATION

P0225 – JOG SELECTION – LOCAL SITUATION

P0226 – FORWARD/REVERSE SELECTION – REMOTE SITUATION

P0227 – RUN/STOP SELECTION – REMOTE SITUATION

P0228 – JOG SELECTION – REMOTE SITUATION

Description:

These parameters are used to configure the command sources for CFW500 frequency inverter local and remote situations. To control the device through the Ethernet interface, select the options 'Ethernet' available in these parameters.

The detailed description of these parameters is found in the CFW500 programming manual.

P0313 – ACTION IN CASE OF COMMUNICATION ERROR (FIELD BUS)

Range:	0 = Inactive 1 = Disable via Run/Stop 2 = Disable via General Enable 3 = Change to Local 4 = Change to Local keeping commands and reference 5 = Causes a Fault	Default: 1
Properties:	CFG	

Description:

It allows the selection of the action performed by the device, if it is controlled via network and detects a communication error.

Table 5.1: P0313 options

Options	Description
0 = Inactive	It takes no action and the device remains in the existing status.
1 = Disable via Run/Stop	It performs a stop command and the motor stops according to the programmed deceleration ramp.
2 = Disable via General Enable	The device is disabled by removing the General Enabling and the motor coasts to stop.
3 = Change to Local	The device commands change to Local.
4 = Change to Local keeping commands and reference	The device commands change to Local, but the enabling commands and speed reference received via network are kept, if the device has been programmed to use, in Local mode, the commands via HMI or 3-wire start/stop, and speed reference via either HMI or electronic potentiometer.
5 = Causes a Fault	Instead of an alarm, the communication error causes a device fault, so that a fault reset becomes necessary in order to restore normal operation.

The device consider the following events as communication errors:

- Alarm A148/Fault F248: device goes to offline.
- Alarm A149/Fault F249: Ethernet interface access error.

The actions described in this parameter are done by means of the automatic writing of the selected actions in the respective bits of the interface control words. Therefore, in order that the commands written in this parameter be effective, it is necessary that the device be programmed to be controlled via the used network interface (with exception of option “Causes a Fault”, which blocks the equipment even if it is not controlled by network). This programming is achieved by means of parameters P0220 to P0228.

P0680 – LOGICAL STATUS

Range:	0000h ... FFFFh	Default: -
Properties:	RO	

Description:

It allows the device status monitoring. Each bit represents a specific status:

Bit	15	14	13	12	11	10	9	8	7	6	5	4	3	2	1	0
Function	Fault condition	Automatic (PID)	Undervoltage	LOC/REM	JOG	Speed direction	General enable active	Motor Running	Alarm condition	In configuration mode	Second ramp	Quick stop active	Reserved			

Table 5.2: P0680 parameter bit functions

Bit	Value/Description
Bit 0 ... 3	Reserved
Bit 4 Quick stop active	0: The quick stop command is not active. 1: The drive is executing the quick stop command.
Bit 5 Second ramp	0: The drive is configured to use the first ramp values, programmed in P0100 and P0101, as the motor acceleration and deceleration ramp times. 1: The drive is configured to use the second ramp values, programmed in P0102 and P0103, as the motor acceleration and deceleration ramp times.
Bit 6 In configuration mode	0: The drive is operating normally. 1: The drive is in the configuration mode. It indicates a special condition during which the drive cannot be enabled: <ul style="list-style-type: none"> ▪ Running the self-tuning routine. ▪ Running the oriented start-up routine. ▪ Running the HMI copy function. ▪ Running the flash memory card self-guided routine. ▪ There is a parameter setting incompatibility. ▪ There is no power at the device power section.
Bit 7 Alarm condition	0: The drive is not in alarm condition. 1: The drive is in alarm condition.
Bit 8 Motor Running	0: The motor is stopped (or coast to stop). 1: The drive is running the motor at the set point speed, or executing either the acceleration or the deceleration ramp.
Bit 9 General enable active	0: General Enable is not active. 1: General Enable is active and the drive is ready to run the motor.
Bit 10 Speed direction	0: The motor is running in the reverse direction. 1: The motor is running in the forward direction.
Bit 11 JOG	0: JOG function disabled. 1: JOG function enabled.
Bit 12 LOC/REM	0: Drive in Local mode. 1: Drive in Remote mode.
Bit 13 Undervoltage	0: No Undervoltage. 1: With Undervoltage.
Bit 14 Automatic (PID)	0: PID in manual mode. 1: PID in Automatic mode.
Bit 15 Fault condition	0: The drive is not in a fault condition. 1: The drive has detected a fault.

P0681 – MOTOR SPEED IN 13 BITS

Range: -32768 ... 32767

Default: -

Properties: RO

Description:

It allows monitoring the motor speed. This word uses 13-bit resolution with signal to represent the motor rated frequency (P0403):

$$P0681 = 0000h \text{ (0 decimal)} \quad \rightarrow \quad \text{motor speed} = 0$$

$$P0681 = 2000h \text{ (8192 decimal)} \quad \rightarrow \quad \text{motor speed} = \text{rated frequency (P0403)}$$

Intermediate or higher frequency values can be obtained by using this scale. E.g., for a 60Hz rated frequency motor, if the value read is 2048 (0800h), then, to obtain the value in Hz one must calculate:

$$8192 \Rightarrow 60 \text{ Hz}$$

$$2048 \Rightarrow \text{Frequency}$$

$$\text{Frequency} = \frac{2048 \times 60}{8192}$$

$$\text{Frequency} = 15 \text{ Hz}$$

Negative values in this parameter indicate that the motor is running in the reverse direction.

NOTE!

The values transmitted over the network have a scale limitation, allowing a maximum of 4 times the rated frequency of the motor, with saturation in 32767 (or -32768).

P0684 – CONTROL WORD
Range: 0000h ... FFFFh

Default: 0000h

Properties: RW

Description:

It is the Ethernet interface control word. This parameter can only be changed via Ethernet interface. For the other sources (HMI, etc.) it behaves like a read-only parameter.

In order to control the device using those commands, it is necessary to program the equipment to be controlled via Ethernet. This programming is achieved by means of parameters P0105 and P0220 to P0228.

Each bit of this word represents a command.

Bit	15	14	13	12	11	10	9	8	7	6	5	4	3	2	1	0
Function	Reserved								Fault reset	Quick stop	Second ramp	LOC/REM	JOG	Speed direction	General enable	Stop/Run

Table 5.3: Bit function for parameter P0684

Bit	Value/Function
Bit 0 Stop/Run	0: It stops the motor with deceleration ramp. 1: The motor runs according to the acceleration ramp.
Bit 1 General enable	0: It disables the drive, interrupting the supply for the motor. 1: It enables the drive allowing the motor operation.
Bit 2 Speed direction	0: Direction of rotation is opposed to the speed reference (reverse). 1: Direction of rotation is the same as the speed reference (direct).
Bit 3 JOG	0: It disables the JOG function. 1: It enables the JOG function.
Bit 4 LOC/REM	0: The drive goes to the Local mode. 1: The drive goes to the Remote mode.
Bit 5 Second ramp	0: The drive uses the first ramp values, programmed in P0100 and P0101, as the motor acceleration and deceleration ramp times. 1: The drive is configured to use the second ramp values, programmed in P0102 and P0103, as the motor acceleration and deceleration ramp times.
Bit 6 Quick stop	0: It does not execute the quick stop command. 1: It executes the quick stop command.
Bit 7 Fault reset	0: No function. 1: If in a fault condition, then it executes the fault reset.
Bit 8...15	Reserved

P0685 – SPEED REFERENCE
Range: -32768 ... 32767

Default: 0

Properties: RW

Description:

It is the Ethernet interface motor speed reference. This parameter can only be changed via Ethernet interface. For the other sources (HMI, etc.) it behaves like a read-only parameter.

To use the reference written in this parameter, it is necessary to program the drive to use the speed reference via Ethernet. This programming is achieved by means of parameters P0221 and P0222.

This word uses a 13-bit resolution with signal to represent the motor rated frequency (P0403):

$$\begin{aligned}
 P0685 = 0000h \text{ (0 decimal)} & \rightarrow \text{speed reference} = 0 \\
 P0685 = 2000h \text{ (8192 decimal)} & \rightarrow \text{speed reference} = \text{rated frequency (P0403)}
 \end{aligned}$$

Intermediate or higher reference values can be programmed by using this scale. E.g. for a 60Hz rated frequency motor, to obtain a reference of 30 Hz, one must calculate:

$$60 \text{ Hz} \Rightarrow 8192$$

$$30 \text{ Hz} \Rightarrow \text{Reference in 13 bits}$$

$$\text{Reference in 13 bits} = \frac{30 \times 8192}{60}$$

$$\text{Reference in 13 bits} = 4096 \Rightarrow \text{Value corresponding to 30 Hz in a 13 bit scale}$$

This parameter also accepts negative values to revert the motor speed direction. The speed reference direction, however, depends also on the bit 2 of control word:

- Bit 2 = 1 and P0685 > 0: forward direction of rotation
- Bit 2 = 1 and P0685 < 0: reverse direction of rotation
- Bit 2 = 0 and P0685 > 0: reverse direction of rotation
- Bit 2 = 0 and P0685 < 0: forward direction of rotation

NOTE!

The values transmitted over the network have a scale limitation, allowing to program a speed reference of 4 times the rated frequency of the motor, with saturation in 32767 (or -32768).

P0695 – DIGITAL OUTPUTS SETTING

Range:	00000b ... 11111b	Default: 00000b
Properties:	RW	

Description:

It allows the control of the digital outputs by means of the network interfaces (Ethernet, etc.). It is not possible to change this parameter via HMI.

Each bit of this parameter corresponds to the desired value for one digital output. In order to control the correspondent digital output according to this content, it is necessary that its function be programmed for "P0695 Content" at parameters P0275 to P0279.

Bit	15	14	13	12	11	10	9	8	7	6	5	4	3	2	1	0
Function	Reserved											Value for DO5	Value for DO4	Value for DO3	Value for DO2	Value for DO1

Table 5.4: Bit function for parameter P0695

Bit	Valor/Descrição
Bit 0 Value for DO1	0: Open DO1. 1: Close DO1.
Bit 1 Value for DO2	0: Open DO2. 1: Close DO2.
Bit 2 Value for DO3	0: Open DO3 . 1: Close DO3.
Bit 3 Value for DO4	0: Open DO4. 1: Close DO4.
Bit 4 Value for DO5	0: Open DO5. 1: Close DO5.
Bit 5...15	Reserved.

NOTE!

Some of the digital outputs may not be available depending on the plug-in module.

P0696 - VALUE 1 FOR ANALOG OUTPUTS
P0697 - VALUE 2 FOR ANALOG OUTPUTS
P0698 - VALUE 3 FOR ANALOG OUTPUTS
Range: -32768 ... 32767

Default: 0

Properties: RW

Description:

They allow the control of the analog outputs by means of network interfaces (Ethernet, etc.). It is not possible to change this parameter via HMI.

The value written in these parameters may control the analog output value, as long as you program the option “P0696 ... P0698 value” at the analog output function parameters.

The value must be written in a 15-bit¹ scale (7FFFh = 32767) to represent 100 % of the output desired value, i.e.:

- P0696 = 0000h (0 decimal) → analog output value = 0 %
- P0696 = 7FFFh (32767 decimal) → analog output value = 100 %

The showed example was for P0696, but the same scale is also used for the other parameters. For instance, to control the analog output 1 via Ethernet, the following programming must be done:

- Choose a parameter from P0696 ... P0698 to be the value used by the analog output 1. For this example, we are going to select P0696.
- Program the option “P0696 value” as the function for the analog output 1 in P0254.
- Using the network interface, write in P0696 the desired value for the analog output 1, between 0 and 100 %, according to the parameter scale.

¹For the actual output resolution, refer to the product manual.

P0800 – ETHERNET MODULE IDENTIFICATION

Range:	0 = Not Identified 1 = Modbus TCP 2 = EtherNet/IP 3 = PROFINET IO	Default: -
Properties:	RO, ETH	
Access Groups:	NET	

Description:

It allows identifying the Ethernet module type connected to the equipment.

Table 5.5: P0800 indications

Indication	Description
0 = Not Identified	Module not connected / not identified.
1 = Modbus TCP	Ethernet module for communication with Modbus TCP protocol.
2 = EtherNet/IP	Ethernet module for communication with EtherNet/IP protocol.
3 = PROFINET IO	Ethernet module for communication with PROFINET IO protocol.

P0801 – ETHERNET COMMUNICATION STATUS

Range:	0 = Setup 1 = Init 2 = Wait Comm 3 = Idle 4 = Data Active 5 = Error 6 = Reserved 7 = Exception 8 = Access Error	Default: -
Properties:	RO, ETH	
Access Groups:	NET	

Description:

It allows identifying the Ethernet communication status.

Table 5.6: P0801 indications

Indication	Description
0 = Setup	Module identified, waiting configuration data (automatic).
1 = Init	Module performing interface initialization procedure (automatic).
2 = Wait Comm	Initialization finished, but no communication with master.
3 = Idle	Communication with master established, but in Idle mode or Program mode.
4 = Data Active	Communication with master established and performing normal I/O data handling. "On-line".
5 = Error	Communication error detected.
6	Reserved
7 = Exception	Major fault detected by the Ethernet interface. Requires interface reinitialization.
8 = Access error	Major fault detected between device and Ethernet interface. Requires interface reinitialization.

P0803 – ETHERNET BAUD RATE

Range:	0 = Auto 1 = 10Mbit/s, half duplex 2 = 10Mbit/s, full duplex 3 = 100Mbit/s, half duplex 4 = 100Mbit/s, full duplex	Default: 0
Properties:	RW, ETH	
Access Groups:	NET	

Description:

It allows to set the desired baud rate for the Ethernet interface.



NOTE!

- For the changes in this parameter be effective, the equipment must be powered off and on again, or an update must be performed by P0849.
- For PROFINET interface, the baud is locked to 100Mbit/s as required by the protocol.

P0806 – MODBUS TCP WATCHDOG

Range:	0.0 to 65.5 s	Default: 0.0
Properties:	RW, ETH	
Access Groups:	NET	

Description:

It allows programming a time limit for the detection of Ethernet offline error, for Modbus TCP protocol. If the CFW500 remains without receiving valid telegrams longer than the time programmed in this parameter, it will be considered that a communication error has occurred, the alarm A0149 will be showed on the HMI and the option programmed in P0313 will be executed.

After being powered up, the CFW500 starts counting this time from the first received valid telegram. The value 0.0 disables this function.



NOTE!

For the changes in this parameter be effective, the equipment must be powered off and on again, or an update must be performed by P0849.

P0810 – IP ADDRESS CONFIGURATION

Range:	0 = Parameters 1 = DHCP	Default: 1
Properties:	RW, ETH	
Access Groups:	NET	

Description:

It allows to choose how to set the IP address for the Ethernet modules.

Table 5.7: P0810 options

Option	Description
0 = Parameters	The settings for IP address, sub-net mask and gateway shall be done by means of parameters P0811 to P0819.
1 = DHCP	Enables DHCP function. A DHCP server should set the IP address, sub-net mask and gateway through network.

NOTE!

For the changes in this parameter be effective, the equipment must be powered off and on again, or an update must be performed by P0849.

P0811 - IP ADDRESS 1
P0812 - IP ADDRESS 2
P0813 - IP ADDRESS 3
P0814 - IP ADDRESS 4

Range:	0 ... 255	Default: 192.168.0.14
Properties:	RW, ETH	
Access Groups:	NET	

Description:

If P0810 = 0 (parameters), these parameters allow you to program the IP address of the Ethernet module. For other option of P0810, these parameters have no function.

Each parameter programs one octet of the IP address, where the P0811 is the most significant octet. The programmed IP address, then, has the format "P0811.P0812.P0813.P0814".

NOTE!

For the changes in this parameter be effective, the equipment must be powered off and on again, or an update must be performed by P0849.

P0815 - SUBNET CIDR

Range:	1 ... 31	Default: 24
Properties:	RW, ETH	
Access Groups:	NET	

Description:

If P0810 = 0 (parameters), this parameters allow you to program the sub-net mask for the Ethernet module. The subnet mask can usually be programmed using a notation with 4 octets separated by dots, or CIDR notation, in which the value is the number of bits with value "1" in the subnet mask. For other option of P0810, this parameter has no function.

The following table shows the allowed values for the CIDR notation and equivalent dot notation for the subnet mask:

Table 5.8: P0815 options

CIDR	Sub-net mask	CIDR	Sub-net mask
1	128.0.0.0	17	255.255.128.0
2	192.0.0.0	18	255.255.192.0
3	224.0.0.0	19	255.255.224.0
4	240.0.0.0	20	255.255.240.0
5	248.0.0.0	21	255.255.248.0
6	252.0.0.0	22	255.255.252.0
7	254.0.0.0	23	255.255.254.0
8	255.0.0.0	24	255.255.255.0
9	255.128.0.0	25	255.255.255.128
10	255.192.0.0	26	255.255.255.192
11	255.224.0.0	27	255.255.255.224
12	255.240.0.0	28	255.255.255.240
13	255.248.0.0	29	255.255.255.248
14	255.252.0.0	30	255.255.255.252
15	255.254.0.0	31	255.255.255.254
16	255.255.0.0		



NOTE!

For the changes in this parameter be effective, the equipment must be powered off and on again, or an update must be performed by P0849.

P0816 - GATEWAY 1

P0817 - GATEWAY 2

P0818 - GATEWAY 3

P0819 - GATEWAY 4

Range:	0 ... 255	Default: 0.0.0.0
Properties:	RW, ETH	
Access Groups:	NET	

Description:

If P0810 = 0 (parameters), these parameters allow you to program the IP address of the default gateway for the Ethernet modules. For other option of P0810, these parameters have no function.

Each parameter programs one octet of the gateway address, where the P0816 is the most significant octet. The programmed gateway IP address, then, has the format "P0816.P0817.P0818.P0819".



NOTE!

For the changes in this parameter be effective, the equipment must be powered off and on again, or an update must be performed by P0849.

P0820 ... P0831 - ETHERNET READ WORDS #3 ... #14

Range:	0 ... 9999	Default: 0
Properties:	RW, ETH	
Access Groups:	NET	

Description:

These parameters allow programming the number of read words (inputs: slave → master), as well as the content of each word.

The first two read words are pre-defined, representing the value of the status word and motor speed, and are always sent to the network master. The words #3 to #14 can be programmed by the user. By using these parameters it is possible to program the number of another parameter whose content must be made available at the network master input area. If, for instance, one wants to read from the CFW500 frequency inverter the motor current in Amps, one must program the value 3 in one of these parameters, because the parameter P0003 is the one that contains this information. It is worthwhile to remind that the value read from any parameter is represented with a 16 bit word. Even if the parameter has decimal resolution, the value is transmitted without the indication of the decimal places. E.g., if the parameter P0003 has the value 4.7A, the value supplied via the network will be 47.

The number of read words is defined by programming zero in the last parameter required for communication. Besides the two predefined words, it will also be added to the input area the words programmed in these parameters if the contents programmed for these parameters is different from zero. The first parameter set to zero disables the use of itself and the other parameters in the sequence. For example, if you set P0820 = 0, only two predefined read words (state and speed) will be communicated with the master.

Table 5.9: Read words programming

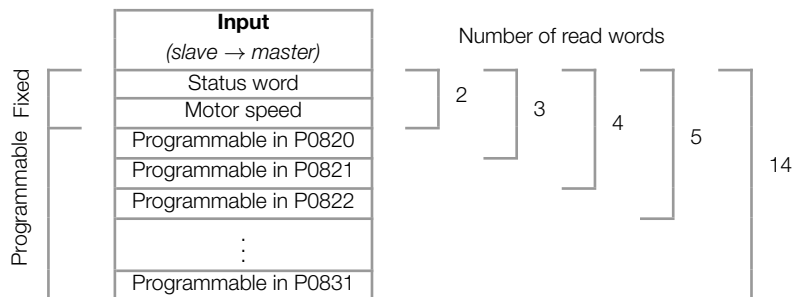

The same number of words programmed into the equipment must be programmed in the master when configuring the network.



NOTE!

If, after parameter settings, the number of words changes, to make the new configuration effective the equipment must be powered off and on again, or an update must be performed by P0849.

P0835 ... P0846 - ETHERNET WRITE WORDS #3 ... #14

Range:	0 ... 9999	Default: 0
Properties:	RW, ETH	
Access Groups:	NET	

Description:

These parameters allow programming the number of write words (outputs: master → slave), as well as the content of each word.

The first two write words are pre-defined, representing the value of the control word and speed reference, and are always received from the network master. The words #3 to #14 can be programmed by the user. By using these parameters it is possible to program the number of another parameter whose content must be made available at the network master output area. If, for instance, one wants to write to the CFW500 frequency inverter the acceleration ramp, one must program the value 100 in one of these parameters, because the parameter P0100 is the one to program this information. It is worthwhile to remind that the value written from any parameter is represented with a 16 bit word. Even if the parameter has decimal resolution, the value is transmitted without the indication of the decimal places. E.g., if the parameter P0100 has the value 5.0s, the value supplied via the network will be 50.

The number of write words is defined by programming zero in the last parameter required for communication. Besides the two predefined words, it will also be added to the output area the words programmed in these parameters if the contents programmed for these parameters is different from zero. The first parameter set to zero disables the use of itself and the other parameters in the sequence. For example, if you set P0835 = 0, only two predefined write words

(control and reference) will be communicated with the master.

Table 5.10: Write words programming

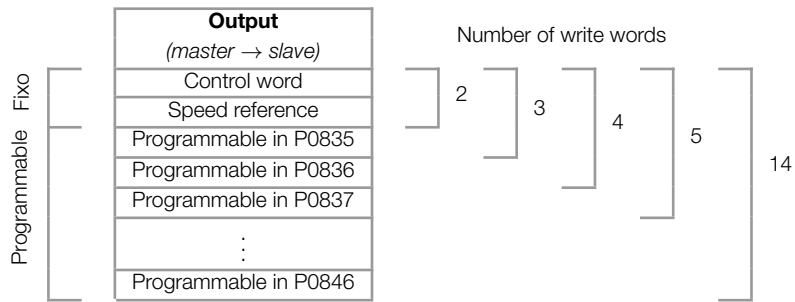

The same number of words programmed into the equipment must be programmed in the master when configuring the network.



NOTE!

If, after parameter settings, the number of words changes, to make the new configuration effective the equipment must be powered off and on again, or an update must be performed by P0849.

P0849 – UPDATE ETHERNET CONFIGURATION

Range:	0 = Normal Operation 1 = Update configuration	Default: 0
Properties:	RW, ETH	
Access Groups:	NET	

Description:

It allows you to force a reset of the Ethernet interface, to update the settings made in the device parameters. When setting this parameter to "1", the Ethernet interface is restarted, resulting in loss of communication during this process. After the process is complete, the parameter switch automatically to "0".

6 MODBUS TCP

This chapter shows operating characteristics of the frequency inverter CFW500 using the plug-in module for communication as Modbus TCP server.

6.1 INDICATION LEDS

The MS and NS LEDs have the following information for Modbus TCP protocol:

Table 6.1: Module Status LED (MS)

State	Description
Off	No power or initialization.
Green, solid	Normal operation.
Red, solid	Fatal error (interface must be reinitialized).
Red, flashing	IP address is invalid/duplicated.

Table 6.2: Network Status LED (NS)

State	Description
Off	No power or no IP address.
Green, solid	Connection established.
Green, flashing	Waiting for connections.
Red, solid	Duplicate IP address, or fatal error (interface must be reinitialized).
Red, flashing	Modbus communication timed out

6.2 AVAILABLE FUNCTIONS

In the Modbus specification are defined the functions used to access different types of data. In the CFW500, in order to access those data the following services (or functions) have been made available:

Table 6.3: Supported Modbus Functions

Code	Name	Description
01	Read Coils	Reading of bit blocks of the coil type.
02	Read Discrete Inputs	Reading of bit blocks of the discrete input type.
03	Read Holding Registers	Reading of register blocks of the holding register type.
04	Read Input Registers	Reading of register blocks of the input register type.
05	Write Single Coil	Writing in a single bit of the coil type.
06	Write Single Register	Writing in a single register of the holding type.
15	Write Multiple Coils	Writing in bit blocks of the coil type.
16	Write Multiple Registers	Writing in register blocks of the holding register type.
43	Read Device Identification	Identification of the device model.

6.3 MEMORY MAP

The frequency inverter CFW500 has different types of data accessible through the Modbus communication. These data are mapped at data addresses and access functions as described in the following items.

6.3.1 Parameters

The CFW500 Modbus communication is based on the reading/writing of the equipment parameters. All the drive parameters list is made available as 16-bit holding registers type. The data addressing is done with the offset equal to zero, which means that the parameter number corresponds to the register number. The following table illustrates the parameters addressing, which can be accessed as holding register.

Table 6.4: Parameters Access - Holding Registers

Parameter	Modbus data address (decimal)
P0000	0
P0001	1
⋮	⋮
P0100	100
⋮	⋮

It is necessary to know the device list of parameters to be able to operate the equipment. Thus, it is possible to identify what data are needed for the status monitoring and the control of the functions. The main parameters are:

Monitoring (reading):

- P0680 (holding register 680): Status word
- P0681 (holding register 681): Motor speed

Command (writing):

- P0682 (holding register 682): Command Word
- P0683 (holding register 683): Speed Reference

Refer to the Programming Manual for a complete parameter list of the equipment.



NOTE!

- All the parameters are treated as holding registers. Depending on the master that is used, those registers are referenced starting from the base address 40000 or 4x. In this case, the address that must be programmed in the master for a parameter is the address showed in the table above added to the base address. Refer to the master documentation to find out how to access holding registers.
- It should be noted that read-only parameters can only be read from the equipment, while other parameters can be read and written through the network.

6.3.2 Memory Markers

Besides the parameters, other types of data as bit markers, word or float, can also be accessed using the Modbus protocol. Those markers are used mainly by the SoftPLC function, available for the CFW500. Refer to the SoftPLC documentation for the description of those markers, as well as for the addresses via Modbus.

6.4 COMMUNICATION ERRORS

Communication errors may occur in the transmission of telegrams, as well as in the contents of the transmitted telegrams. Transmission and connection errors are directly processed by the Ethernet interface and by the TCP/IP protocol.

In the event of a successful reception, during the treatment of the telegram, the server may detect problems and send an error message, indicating the kind of problem found:

Table 6.5: Error codes for Modbus

Error Code	Description
1	Invalid function: the requested function is not implemented for the equipment.
2	Invalid data address: the data address (register or bit) does not exist.
3	Invalid data value: <ul style="list-style-type: none"> ▪ Value out of the allowed range. ▪ Writing on data that cannot be changed (read only register or bit).



NOTE!

It is important that it be possible to identify at the client what type of error occurred, in order to be able to diagnose problems during the communication.

6.5 STARTUP GUIDE

The following items describe main steps for CFW500 commissioning using the Modbus TCP protocol. The steps represent an example of use. Refer to specific chapters for details on the steps.

6.5.1 Installing the Ethernet Module

1. Install the Ethernet communication module, as indicated in the instructions that came with the module.
2. Connect the Ethernet cable to the module, considering the recommended instructions in network installation, as described in item 4:
 - Use shielded cable.
 - Properly ground network equipment.
 - Avoid laying communication cables next to power cables.

6.5.2 Configuring the Drive

1. Follow the recommendations described in the user's manual to program the device parameters related to motor settings, desired operation mode, I/O signs, etc.
2. Program command sources for local and remote mode, as desired for application.
3. Program communication parameters such as DHCP, IP address, baud rate, etc.
4. Program the timeout for Modbus TCP communication in parameter P0806.
5. Define which parameters will be read and written at CFW500 frequency inverter, based on its parameter list. It is not necessary to define I/O words. The Modbus TCP protocol enables direct access to any device parameter, and does not distinguish between cyclic and acyclic data. The main parameters that can be used to control the device, we can mention:
 - P0680 - Status Word

- P0681 - Speed in 13 bits
 - P0684 - Control Word
 - P0685 - Speed reference
6. If necessary, restart the Ethernet module using the P0849.

6.5.3 Configuring the Master

The way you do the network setup is highly dependent on the network master and the network configuration tool. It is important to know the tools used to perform this activity. In general, the following steps are required to perform the network configuration.

1. Program the master to read and write holding registers, based on the defined equipment parameters to read and write. The register number is based on the parameter number, as shown in table 6.4.
2. It is recommended that reading and writing are done in a cyclic manner, allowing detection of communication errors by timeout.

6.5.4 Communication Status

Once you install the network and program the master, you can use the LEDs and equipment parameters to identify some states related to communication.

- The LEDs "MS", "NS" and "Link" provide information about the state of the interface and communication.
- The parameter P0801 indicates the status of communication between the device and the network master.

The network master must also provide information about communication with slave.

6.5.5 Operation Using Process Data

Once communication is established, data is written and read by the Modbus TCP network master automatically. Using these parameters, the master is able to control the equipment and monitor its operation. It is important to know the device parameters to program the master as desired for the application.

7 ETHERNET/IP

Following it shows operating characteristics of the CFW500 frequency inverter using the plug-in module for EtherNet/IP communication.

7.1 INDICATION LEDS

The MS and NS LEDs present on the Ethernet module, have the following information for EtherNet/IP protocol:

Table 7.1: Module Status LED (MS)

State	Description
Off	No power.
Green, solid	Controlled by a Scanner in Run state.
Green, flashing	Not configured, or scanner in Idle state.
Red, solid	Fatal error (interface must be reinitialized).
Red, flashing	Recoverable fault.

Table 7.2: Network Status LED (NS)

State	Description
Off	No power or no IP address.
Green, solid	Connection established.
Green, flashing	Waiting for connections.
Red, solid	Duplicate IP address, or fatal error (interface must be reinitialized).
Red, flashing	One or more I/O connection timed out.

7.2 CYCLIC DATA

Cyclic data is the data normally used for status monitoring and equipment control. For EtherNet/IP protocol, the interface supports an I/O connection that allows communication up to 14 input words and 14 output words.

It is necessary the configuration to be made both at the slave and master.

7.3 ACYCLIC DATA

In addition to the cyclic data, the interface also provides acyclic data via explicit messaging. Using this type of communication, you can access any equipment parameter. Access to this type of data is commonly done using instructions for reading or writing data, which should indicate the class, instance, and attribute to the desired parameter. The following table describes how to address the parameters for CFW500 frequency inverter.

Table 7.3: Parameter Addressing

Parameter	Class	Instance	Atribute
P0001	162 (A2h)	1	5
P0002	162 (A2h)	2	5
P0003	162 (A2h)	3	5
⋮	⋮	⋮	⋮
P0400	162 (A2h)	400	5
⋮	⋮	⋮	⋮

The data is transmitted as an integer value, without the indication of the decimal places.

7.4 EDS FILE

Each device on an EtherNet/IP network has an EDS configuration file, which contains information about the device functions on the network. This file is used by a master or configuration software to program devices present at EtherNet/IP network.

The EDS configuration file is supplied on a CD with the product. Observe the software version of the equipment, to use an EDS file that is compatible with this version.

7.5 MODBUS TCP CONNECTIONS

The plug-in module for EtherNet/IP also provides up to 2 Modbus TCP connections. These connections can be used for parameterization, as well as access to markers and data used for CFW500 ladder programming. The available Modbus functions and communication data are described in item 6.

7.6 STARTUP GUIDE

Next it describes the main steps for commissioning CFW500 frequency inverter on Ethernet network using the EtherNet/IP protocol. These steps represent an example of use. Refer to specific chapters for details on the steps.

7.6.1 Installing the Ethernet Module

1. Install the Ethernet communication module, as indicated in the installation guide supplied with the module.
2. Connect the Ethernet cable to the module, considering the necessary care in network installation, as described in section 4:
 - Use shielded cable.
 - Properly ground the network devices.
 - Avoid laying communication cables next to power cables.

7.6.2 Configuring the Drive

1. Follow the recommendations described in the user's manual to program the related to device settings, motor parameters, desired functions for I/O signs, etc..
2. Program command sources for local and remote mode, as desired for application.
3. Program communication parameters such as DHCP, IP address, baud rate, etc.
4. Set the desired action for communication errors, through the P0313.
5. Set number of I/O words as well as the contents of each word using parameters P0820 to P0831 and P0835 to P0846.
6. If necessary, restart the Ethernet module using P0849.

7.6.3 Configuring the Master

The way you do the network setup depends largely on the master and the configuration tool. It is important to know these tools to perform this activity. In general, the following steps are required to do the network configuration.

1. Load the EDS file on the CD that supplied with the product ² to the list of devices in the network configuration tool.
2. Select CFW500 frequency inverter from the available list of devices on the network configuration tool. This can be done manually or automatically, if allowed by the tool.
3. For the master configuration, in addition to the IP address used by the EtherNet/IP module, you must indicate the number of instances of I/O and the amount of data exchanged with the master in each instance. For the communication module for EtherNet/IP, the following values must be programmed:
 - Input instance: 100
 - Output instance: 150
4. The EtherNet/IP module is described as “Generic Ethernet Module” on the device list. Using these settings you can program the network master to communicate with the equipment.

7.6.4 Communication Status

Once you install the network and program the master, you can use the LEDs and equipment parameters to identify some states related to communication.

- The LEDs “MS”, “NS” and “Link” provide information about the state of the interface and communication.
- The parameter P0801 indicates the status of communication between the device and the network master.

The network master must also provide information about the communication with slave.

7.6.5 Operation Using Process Data

Once the communication is established, the data mapped in the I/O area is automatically updated between master and slave. Among the main parameters that can be used to control the device, we can mention:

- P0680 - Status word
- P0681 - Motor speed em 13 bits
- P0684 - Control word
- P0685 - Speed reference

It is important to know these parameters to program the master as desired for the application.

²It is important to note if the EDS configuration file is compatible with the firmware version of CFW500 frequency inverter.

8 PROFINET

Following it shows operating characteristics of the frequency inverter CFW500 using plug-in module for PROFINET communication.

8.1 INDICATION LEDS

The MS and NS LEDs present on the Ethernet module, have the following information for PROFINET protocol:

Table 8.1: Module Status LED (MS)

State	Description
Off	No power or initialization.
Green, solid	Normal operation.
Green, flashing (2 flashes and 1 interval)	Used by engineering tools to identify the node on the network.
Red, solid	Fatal error (interface must be reinitialized).
Red, flashing (1 flash and 1 interval)	Configuration error, expected identification differs from real identification.
Red, flashing (2 flashes and 1 interval)	IP address not set.
Red, flashing (3 flashes and 1 interval)	Station name not set.
Red, flashing (4 flashes and 1 interval)	Internal error (interface must be reinitialized).

Table 8.2: Network Status LED (NS)

State	Description
Off	No power or no connection with controller.
Green, solid	Connection with controller established, controller in RUN mode.
Green, flashing	Connection with controller established, controller in STOP mode.

8.2 CYCLIC DATA

Cyclic data is the data normally used for status monitoring and equipment control. For PROFINET protocol, the interface supports an I/O connection that allows communication up to 14 input words and 14 output words.

It is necessary the configuration to be made both at the slave and master.

8.3 ACYCLIC DATA

In addition to the cyclic data, the PROFINET protocol also provides acyclic data, mainly used to communicate diagnoses data, parameterization and configuration. For the CFW500 frequency inverter using the Ethernet module, the parameter list is available using this communication method.

The PROFINET protocol defines the following structure to address the components for network configuration:

- AR (Application Relation)
- API (Application Process Identifier)
- Slot
- Subslot

The AR and API are used to identify the Ethernet module during the network configuration steps. Slot/subslot are not relevant for accessing acyclic data. Once the module is identified, the parameters are accessed indicating the index and the data length:

- Index: represents the parameter number;
- Length: the length of data, in bytes. All device parameter are 2 bytes in length (Word).

The data is transmitted as an integer value, without the indication of the decimal places.

8.4 XML FILE

Each device on an PROFINET network has an GSDML configuration file, which contains information about the device functions on the network. This file is used by a master or configuration software to program devices present at PROFINET network.

The GSDML configuration file is supplied on a CD with the product. Observe the software version of the equipment, to use an EDS file that is compatible with this version.

8.5 MODBUS TCP CONNECTIONS

The plug-in module for PROFINET IO also provides up to 2 Modbus TCP connections. These connections can be used for parameterization, as well as access to markers and data used for CFW500 ladder programming. The available Modbus functions and communication data are described in item 6.

8.6 STARTUP GUIDE

Next it describes the main steps for commissioning CFW500 frequency inverter on Ethernet network using the PROFINET protocol. These steps represent an example of use. Refer to specific chapters for details on the steps.

8.6.1 Installing the Ethernet Module

1. Install the Ethernet communication module, as indicated in the installation guide supplied with the module.
2. Connect the Ethernet cable to the module, considering the necessary care in network installation, as described in section 4:
 - Use shielded cable.
 - Properly ground the network devices.
 - Avoid laying communication cables next to power cables.

8.6.2 Configuring the Drive

1. Follow the recommendations described in the user's manual to program the related to device settings, motor parameters, desired functions for I/O signs, etc..
2. Program command sources for local and remote mode, as desired for application.
3. Program communication parameters such as DHCP, IP address, baud rate, etc.
4. Set the desired action for communication errors, through the P0313.

5. Set number of I/O words as well as the contents of each word using parameters P0820 to P0831 and P0835 to P0846.
6. If necessary, restart the Ethernet module using P0849.

8.6.3 Configuring the Master

The way you do the network setup depends largely on the master and the configuration tool. It is important to know these tools to perform this activity. In general, the following steps are required to do the network configuration:

1. Load the GSDML file on the CD that supplied with the product³ to the list of devices in the network configuration tool.
2. Select CFW500 frequency inverter from the available list of devices on the network configuration tool. This can be done manually or automatically, if allowed by the tool. The PROFINET module is recognized as "CFW500", at the "General" category.
3. For the master configuration, you must indicate the number of I/O words exchanged with the master. It is necessary to select word by word, first selecting all input words and then all output words.

8.6.4 Communication Status

Once you install the network and program the master, you can use the LEDs and equipment parameters to identify some states related to communication.

- The LEDs "MS", "NS" and "Link" provide information about the state of the interface and communication.
- The parameter P0801 indicates the status of communication between the device and the network master.

The network master must also provide information about the communication with slave.

8.6.5 Operation Using Process Data

Once the communication is established, the data mapped in the I/O area is automatically updated between master and slave. Among the main parameters that can be used to control the device, we can mention:

- P0680 - Status word
- P0681 - Motor speed em 13 bits
- P0684 - Control word
- P0685 - Speed reference

It is important to know these parameters to program the master as desired for the application.

³It is important to note if the GSDML configuration file is compatible with the firmware version of CFW500 frequency inverter.

9 WEB SERVER

Besides the communication protocol, the Ethernet interface also provides a WEB server with a simple HTML page to access CFW500 frequency inverter data. If the IP address is known, you can use a web browser by typing the IP address in the browser address bar, and it will present a web page with links to interface settings and device data.

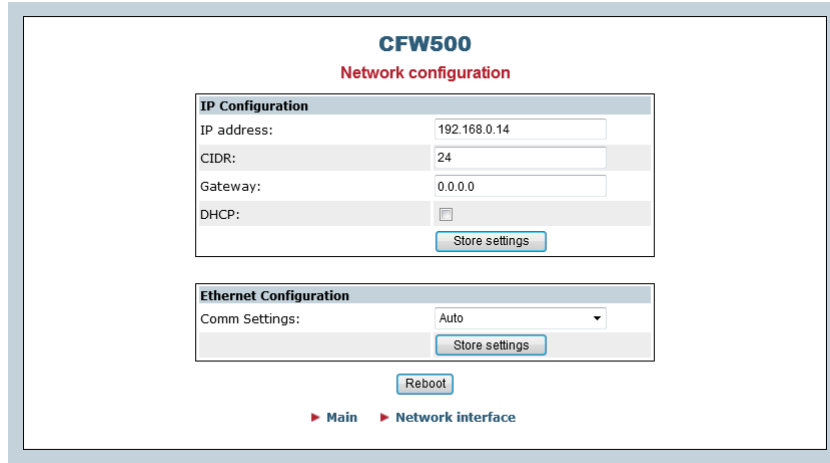

CFW500
Network configuration

IP Configuration	
IP address:	192.168.0.14
CIDR:	24
Gateway:	0.0.0.0
DHCP:	<input type="checkbox"/>
Store settings	

Ethernet Configuration	
Comm Settings:	Auto
Store settings	

[Reboot](#)

▶ [Main](#) ▶ [Network interface](#)

Figure 9.1: WEB page for interface configuration

In the interface settings, it presents several fields for programming the IP address, subnet, DHCP, among others. The parameter list of the equipment can also be accessed through the WEB browser via "Parameter Data" link. This list is presented in a simplified format, with only the integer values, with no indication of decimal places.

10 FAULTS AND ALARMS

A0148/F0248 - ETHERNET INTERFACE ACCESS ERROR

Description:

Indicates error in data exchange between CFW500 frequency inverter and Ethernet module.

Actuation:

It occurs when the control board can not exchange data with the Ethernet module, when the Ethernet module identifies some internal error, or when there is a hardware incompatibility.

In this case, the device will show in the HMI an alarm message A0148 - or fault F0248, depending on the P0313 programming. You must reboot the Ethernet module, power cycling the product or using P0849.

Possible Causes/Correction:

- Check if Ethernet module is properly connected to product.
- Check if the device firmware version supports this module.
- Hardware errors caused by the improper handling or installation of the accessory can cause this error. If possible, test it by replacing the communication module.

A0149/F0249 - ETHERNET OFFLINE

Description:

Indicates communication failure between the slave and the network controller.

Actuation:

It occurs when, once established communication between the slave and the network master, there is an interruption in this communication. The method for detecting the interruption of communication depends on the network:

- Modbus TCP: not receiving a valid Modbus TCP telegram by preset period at P0806.
- EtherNet/IP: timeout in I/O connection, or master goes to IDLE state.
- PROFINET: timeout on the cyclic communication between master and slave, or master goes to STOP state.

In this case, the device will show in the HMI an alarm message A0149 - or fault F0249, depending on the P0313 programming. In case of alarm, the indication will automatically disappear at the moment when the communication is reestablished.

Possible Causes/Correction:

- Verify whether the network master is properly configured and operating normally.
- Search for short-circuit or bad contact in the communication cables.
- Verify the entire network installation – cable laying, grounding.