

HEPAtech™

Air Purification System

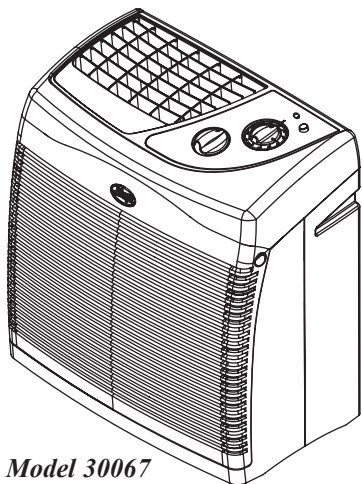

*Model 30067
& 30124*

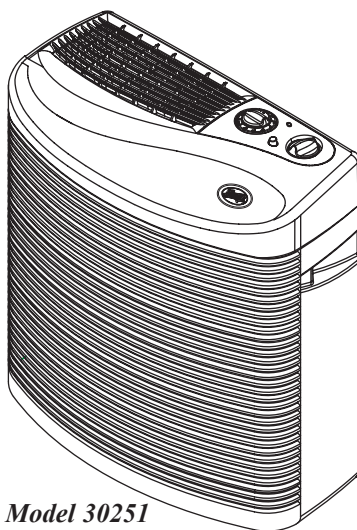

Model 30251

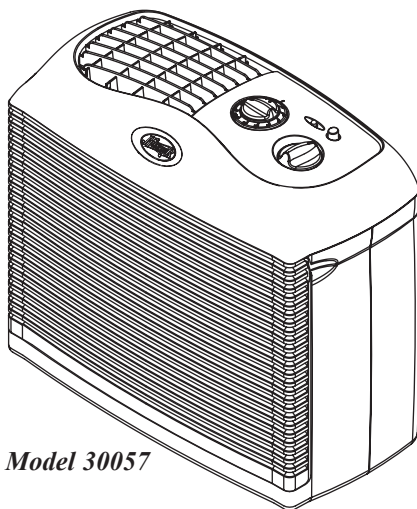

Model 30057



IMPORTANT SAFETY INSTRUCTIONS

READ ALL INSTRUCTIONS BEFORE USING THIS AIR PURIFIER AND SAVE THESE IMPORTANT INSTRUCTIONS

1. **This Air Purifier is designed for use on a flat, level surface and may not work properly on an uneven surface. ALWAYS place this Air Purifier on a firm, level surface. ALWAYS place the Air Purifier at least six (6) inches away from walls and heat sources such as stoves, radiators, or heaters.**
2. **Place the Air Purifier in an area that is out of the reach of children.**
3. **Before using the Air Purifier, extend the cord and inspect for any signs of damage. DO NOT use the product if the cord has been damaged.**
4. **This product has a polarized plug (one blade is wider than the other) as a safety feature. This plug will fit into a polarized outlet only one way. If the plug does not fit fully into the outlet, reverse the plug. If it still does not fit, contact a qualified electrician. DO NOT attempt to defeat or override this safety feature.**
5. **ALWAYS UNPLUG the Air Purifier when it is not in operation, while the filter is being changed, and while it is being cleaned.**
6. **DO NOT tilt or move the Air Purifier while it is in operation. Shut off and unplug before moving.**
7. **DO NOT immerse the Air Purifier in water as permanent damage will occur. Refer to and follow the CLEANING AND FILTER REPLACEMENT instructions.**

Introduction

Thank you for purchasing the HEPAtch™ Air Purification System from Hunter Fan Company. You have purchased our latest development in portable Air Purification Systems. This system has been developed to improve the quality of the air you breathe.

Our HEPAtch™ Air Purification System out performs other air purification systems by quickly and effectively removing dust, smoke, and pollen particles as small as .1 microns in size. Room air is pulled in through the front grill and cleaned across the HEPAtch™ filter. Clean air is then released out the top grill in order to avoid stirring up settled particles.

Using the Ionizer

Using the ionizer improves the quality of air in the room. Negative ions are released into the air and positively charged dust, smoke, and pollen particles are attracted to the negative ions. These particles settle out of the air and can be vacuumed up during normal cleaning. These particles are also more easily captured by the HEPAtch™ filter as they pass through the HEPAtch™ Air Purification System. To ensure the best air circulation in the room, we recommend that you place your air purifier six inches away from any walls.

Using Your Air Purifier

1. Remove your air purifier from the box and take it out of the clear plastic protective bag.
2. Place your HEPAtch™ Air Purification System on a firm, flat surface.
3. Before turning the Air Purifier ‘on’, you need to open the front grill.

For Models 30057 & 30251:

To release the front grill, place your fingers behind the tabs and pull forward.

For Models 30067 & 30124:

To release the front grill, press the buttons on the side until the front grill slides easily over the buttons.

4. The filter will be installed in the correct position. Grasp the filter and pull it forward. Remove the plastic wrapping and replace the filter in the unit. The white filter material should be facing outward (towards you) and the wire mesh side should be hidden from view (inside the unit).
5. Replace the front grill. Be sure that the bottom tabs are in location first, and then push the top of the grill forward until it is closed. The unit is now ready for normal operation. Note: This unit will not operate unless the door is placed in the correct position.
6. Plug the unit into a 120V electrical outlet.

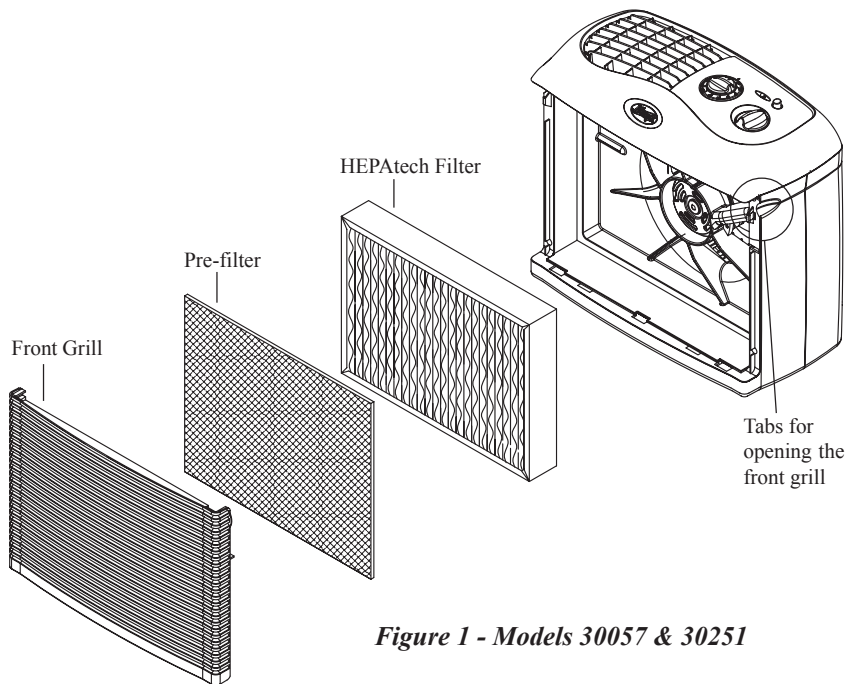

Figure 1 - Models 30057 & 30251

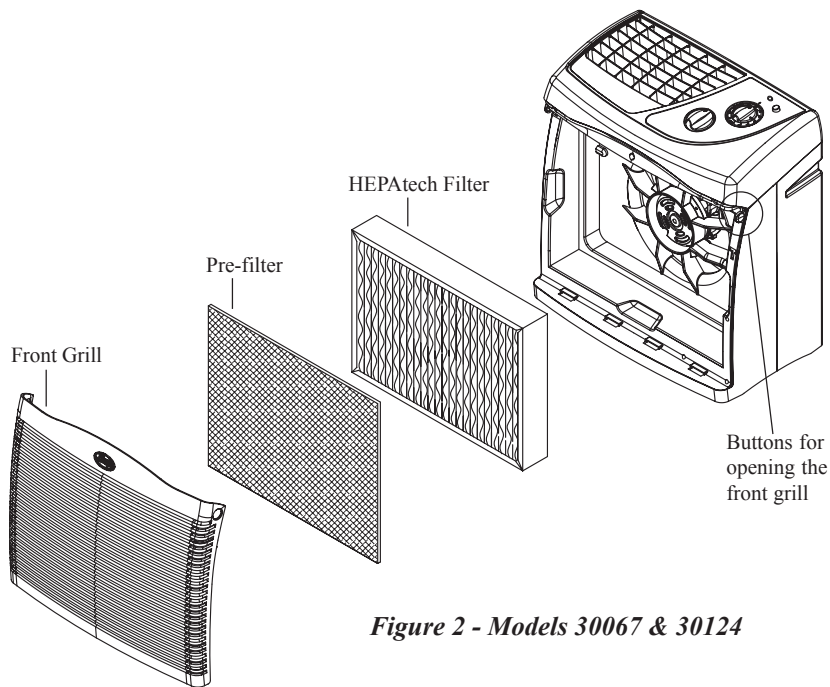

Figure 2 - Models 30067 & 30124

Operating Your Air Purifier

Ionizer: Press this button to turn ‘on’ the ionizer. When the ionizer is ‘on’, the green light near the button will be illuminated.

On/Speed Control: Rotate the Speed Control knob to set the desired speed. A setting of zero (0) indicates that the unit is off, one (1) is low speed, two (2) is medium speed, and three (3) is high speed. The fan speed can be adjusted at any time.

Filter Change Calendar: The filter counter is designed to optimize the performance of the air purifier by reminding you when to change the HEPAtch Filter and pre-filter.

HEPAtch Filter Calendar: The HEPAtch Filter indicator is located at the top of the calendar ring. To set the HEPAtch Filter counter, rotate the calendar ring to align the month that you installed the filter with the top indicator. Since the filter is designed for 6 months use, the two indicators will serve as reminders to change the filter every 6 months.

Pre-filter Calendar: The inner knob of the filter counter is the pre-filter counter. To use, align the knob with the month that you installed the pre-filter. The replace symbol on the inner knob points to the month in which you should install a new pre-filter. The pre-filter is designed for three months of usage.

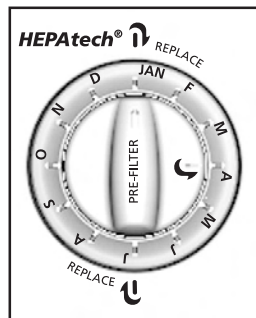

Figure 3 - Calendar Knob

Cleaning And Filter Replacement

1. Clean the outside of the unit with a soft, damp cloth. The front grill can be removed and cleaned in soapy water.
2. At least every 90 days, open the front grill, remove the carbon pre-filter, and replace it. This is necessary to maintain proper odor-removing and overall filtration performance. If necessary, it can be changed more often. Mark the new filter installation sticker included with the new carbon pre-filter. Be sure to remove any plastic wrapping that may be on the new filter before you place it into the Air Purifier.
3. While replacing the pre-filter, you should view the condition of the HEPAtch Filter. Compare the filter to the color coded chart that is on the inside of the housing. If the filter matches the dark color on the chart, you should remove the filter and replace it with a new filter. Be sure to remove any plastic wrapping that may be on the new filter before you place it into the Air Purifier.

Mounting the Air Purifier to the Wall

For Model 30057 Only:

Your air purifier has keyhole slots on the back which can be used to mount your air purifier to the wall. To mount your air purifier to the wall, use plastic dry wall type anchors #14-16 and 1/4" lag screws 1 1/2" long, or equivalent. While your unit is designed to accommodate wall mounting, the optimum performance will be achieved when the unit is placed on the floor, 6 inches away from the walls.

Replacement Filters:

To obtain a replacement filter for your Air Purifier, call 1-800-4Hunter for your nearest retailer or Hunter Customer Service at 901-248-2222. Please be prepared to tell the operator the model number of your Air Purifier and the model number of the filter you need to replace.

Air Purifier Mdl. No.	Filter Mdl. No.	Pre-Filter Mdl. No.
30057	30928	30901
30067	30928	30901
30124	30928	30901
30251	30931	30901

How The HEPAtch™ System Works

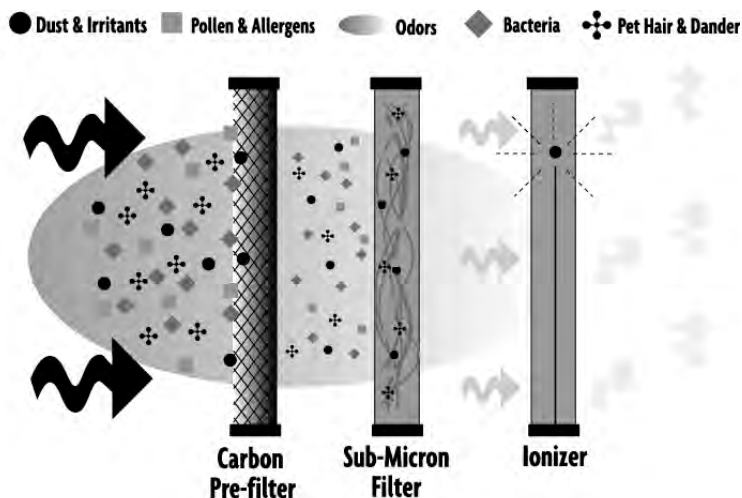

The above is an illustration of how the HEPAtch air purification system works. Dust and other irritants are pulled into the air purification system and cleaned through the HEPAtch Filter. Clean, purified air is then released into the room.

Hunter Fan Company
HEPAtech™ Air Purification System
5 YEAR LIMITED WARRANTY

The Hunter Fan Company makes the following limited warranty to the original residential user or consumer purchaser of the HEPAtch™ Air Purification System:

If any part of your HEPAtch™ Air Purification System (“Air Purifier”) motor fails during the first five (5) years from the date of installation to you due to a defect in material or workmanship, we will provide a replacement Air Purifier free of charge. Installation is deemed to occur at the date of purchase.

If the Air Purifier cord, ionizer, or front grill fails any time within one (1) year after installation due to a defect in material or workmanship, we will replace or, at our option, repair the unit free of charge at our nearest service centre or at our Service Department in Memphis, Tennessee. You will be responsible for all parts and labour costs after this one-year period.

USE OF A NON-HUNTER FILTER WILL INVALIDATE THIS WARRANTY. IF THE ORIGINAL RESIDENTIAL USER OR CONSUMER PURCHASER CEASES TO OWN THE AIR PURIFIER, THIS WARRANTY AND ANY IMPLIED WARRANTY WHICH THEN REMAINS IN EFFECT, INCLUDING BUT NOT LIMITED TO ANY IMPLIED WARRANTY OF MERCHANTABILITY OR FITNESS FOR A PARTICULAR PURPOSE, ARE VOIDED.

NO WARRANTY, EXPRESSED OR IMPLIED, INCLUDING ANY WARRANTY OF MERCHANTABILITY OR FITNESS FOR A PARTICULAR PURPOSE, IS MADE IN RESPECT TO THE FILTER MATERIAL OR CARBON FILTER.

THIS WARRANTY IS IN LIEU OF ALL OTHER EXPRESS WARRANTIES. THE DURATION OF ANY IMPLIED WARRANTY INCLUDING BUT NOT LIMITED TO ANY IMPLIED WARRANTY OF MERCHANTABILITY OR FITNESS FOR A PARTICULAR PURPOSE, IN RESPECT TO THE MOTOR IS EXPRESSLY LIMITED TO THE PERIOD OF THE EXPRESS WARRANTY SET FORTH ABOVE.

This warranty is voided if the air purifier is not purchased and used in the USA or Canada.

This warranty excludes and does not cover defects, malfunctions or failures of the Air Purifier which were caused by repairs by persons not authorized by us, use of parts or accessories not authorized by us, mishandling, modifications, or damage to the Air Purifier while in your possession, or unreasonable use, including failure to provide reasonable and necessary maintenance. This warranty does not cover Air Purifiers used in commercial applications. There are no express or implied warranties as to commercial purchasers or users.

To obtain service, contact the nearest Hunter authorized service centre or the Hunter Fan Company Service Department, 2500 Frisco Avenue, Memphis, Tennessee 38114, 901-248-2222. For the name of our nearest authorized Hunter Fan Company Service Centre, write to the Hunter Fan Company at the preceding address. You will be responsible for insurance and freight or other transportation to our factory service center. We will return the Air Purifier freight prepaid. The Air Purifier should be properly packaged to avoid damage in transit since we will not be responsible for any such damage. Proof of purchase is required when requesting warranty service. The purchaser must present sales receipt or other document that establishes proof of purchase.



Hunter Fan Company
2500 Frisco Avenue
Memphis, Tennessee 38114
<http://www.hunterfan.com>