



User's Manual

LINE THERMAL PRINTER

MODEL **EP-50**

CONTENTS

1	OUTLINE	13
1.1	Features	13
1.2	Unpacking	14
2	BASIC SPECIFICATIONS	15
2.1	Basic specifications	15
2.2	Paper Specifications	16
3	OUTER APPEARANCE AND COMPONENT PARTS	18
4	OPERATION	20
4.1	Connecting AC Adapter	20
4.2	Connecting Interface Cable	21
4.3	Inserting the Paper	21
4.4	Eliminating the Paper Jam	23
4.5	LEDs	24
4.6	FEED Switch Function	24
4.7	Paper End Function	24
4.8	How to Remove Remaining Paper Roll	24
5	DIP SWITCH SETTING	25
5.1	Location of DIP Switch	25
5.2	DIP Switch Function	25
6	SERIAL INTERFACE CABLE ATTACHMENT	27
6.1	Serial Interface	27
6.2	Input-output Signals	27
6.3	Signal Description	27
6.4	Dataflow Control	27
7	POWER CONNECTOR	28
8	COMMAND IIST	29
9	DETAILED DESCRIPTION	31

THE INFORMATION IN THIS DOCUMENT CANNOT BE REPRODUCED IN ANY
MECHANICAL, ELECTRICAL OR ELECTRONIC WAY AND UNDER ANY
CIRCUMSTANCES WITHOUT THE WRITTEN CONSENT FROM DATECS LTD.

Sofia 1784 - BULGARIA, tel: +359 2 974 00 55, fax: +359 2 974 11 00,

e-mail: sales@datecs.bg <http://www.datecs.bg>

VERSION 1.08 / november 2007 / EN

IMPORTANT SAFETY INSTRUCTIONS

- Read all of these instructions and save them for future reference.
- Follow all warnings and instructions marked on the product.
- Unplug this product from the wall outlet before cleaning. Do not use liquid or aerosol cleaners. Use a damp cloth for cleaning.
- Do not use this product near water.
- Do not place this product on an unstable cart, stand or table. The product may fall, causing serious damage to the product.
- Slots and openings on the back or cover these openings. The openings should never be blocked by placing the product on a bed, sofa, rug or other similar surface. This product should never be placed near or over a radiator or heater. This product should not be placed in an built-in installation unless proper ventilation is provided.
- This product should be operated from the type of power source indicated on the marking label. If you are not sure of the type of power available, consult your dealer or local power company.
- Do not allow anything to rest on the power cord. Do not place this product where the cord will be walked on.
- If an extension cord is used with this product, make sure that the total of the ampere ratings of the products plugged into the extension cord does not exceed the extension cord ampere rating. Also, make sure that the total of all products plugged into the wall outlet does not exceed 15 amperes.
- Never push objects of any kind into this product through cabinet slots as they may touch dangerous voltage points or short out parts that could result in a risk of fire or electric shock. Never spill liquid of any kind on the product.
- Except as explained elsewhere in this manual, do not attempt to service this product by yourself. Opening and removing the covers that are marked „Do Not Remove“ may expose you to dangerous voltage points or other risks. Refer all servicing on those compartments service to service personnel.
- Unplug this product from the wall outlet and refer servicing to qualified service personnel under the following conditions:
 - A. When the power cord or plug is damaged or frayed.
 - B. If liquid has been spilled into the product.

- C. If the product has been exposed to rain or water.
 - D. If the product does not operate normally when the operating instructions are followed. Adjust only those controls that are covered by the operating instructions since improper adjustment of other controls may result in damage and will often require extensive work by a qualified technician to restore the product to normal operation.
 - E. If the product has been dropped or the cabinet has been damaged.
 - F. If the product exhibits a distinct change in performance, indicating a need for service.
- Please keep the poly bag which this equipment is packed in away from children or throw it away from children or throw it away to prevent children from putting it on. Putting it on may cause suffocation.

CAUTIONS

- Prior to using the equipment, be sure to read this User's Manual thoroughly. Please keep it handy for reference whenever it may be needed.
- The information contained herein may be changed without prior notice.
- Reproduction of part or all of this User's Manual without permission is strictly prohibited.
- Never service, disassemble, or repair parts that are not mentioned in this User's Manual.
- Note that we will not be responsible for damages attributable to a user's incorrect operation/handling or an improper operating environment .
- Operate the equipment only as described in this User's Manual; otherwise accidents or problems may result.
- Data are basically temporary; they cannot be stored or saved permanently or for a long time. Please note that we will not be responsible for damages or losses of profit resulting from losses of the data attributable to accidents, repairs, tests, and so on.
- If you have any questions or notice any clerical errors or omissions regarding the information in this manual, please contact our office.
- Please note that, notwithstanding them 8 above, we will not be responsible for any effects resulting from operation of the equipment.

SAFETY PRECAUTIONS – BE SURE TO OBSERVE

In order to prevent hazards to an operator or other persons and damage to property, be sure to observe the following precautions.

- The following describes the degrees of hazards and damages that can occur if the given instructions are neglected or the printer is incorrectly operated.

 **WARNING**

Negligence of this precaution may result in death or serious injury.

 **CAUTION**

Negligence of this precaution may result in injury or damage to property.

 This is an illustration mark used to alert your attention.

 This is an illustration mark used to indicate such information as an instruction or the like.

 **WARNING**

- **Never handle the equipment in the following manners, as it may break, become out of order, or overheat causing smoke and resulting in fire or electric shock. If the equipment is used in an abnormal condition, such as when broken, then problems, smoke emission, abnormal odor/noise, and fire can result. If an abnormal condition exists, be sure to disconnect the power plug from a plug socket, and contact our dealer. Never repair the equipment on your own – it is very dangerous.**
- Do not allow the equipment to receive a strong impact or shock, such as kicking, stamping, hitting, dropping, and the like.
- Install the equipment in a well-ventilated place. Do not use it in such a manner that its ventilation port will be blocked.
- Do not install the equipment in a place like a laboratory where chemical reactions are expected, or in a place where salt or gases are contained in the air.
- Do not connect/disconnect a power cord or a data cable, while holding the cable.
- Do not pull, install, use, or carry the equipment in such a manner that force will be applied to the cables.
- Do not drop or insert any foreign substances, such as clips or pins, into the equipment.
- Do not spill any liquid or spray any chemical-containing liquid over the equipment. If any liquid is spilled on it, turn off power, disconnect the power cable and power cord from the plug socket, and contract our dealer.
- Never disassemble or remodel the equipment. Negligence of this may cause fire or electric shock.
- Use the equipment only with the specified commercial power supply and AC adapter. Negligence of this may result in fire, electric shock, or problems.
- If you drop or break the AC adapter, or if water or the like gets inside it, unplug it immediately from the socket and contact your dealer.
- Do not damage, break, process, bend/pull by force, twist, or head an AC adapter cord. Also, do not put a heavy substance on it or heat it. The AC adapter cord could be broken, resulting in fire, electric shock, or trouble. If the AC adapter cord is damaged, contact our dealer.
- Do not connect/disconnect the AC adapter with wet hands.
- Do not overload a single electrical outlet, using a table tap or a current tap socket.
- An equipment packing bag must be discarded or kept away from children. A child can suffocate if the bag is placed over the head.

 **PRECAUTIONS FOR INSTALLATION**

- Do not use or store the equipment in a place exposed to fire, moisture, or direct sunshine, or in a place near a heater or thermal device where the prescribed operating temperature and humidity are not met, or in a place exposed to much oil, iron powder, or dust. The equipment may become out of order, emit smoke, or catch fire.
- Do not install or use the equipment in a place like a laboratory where chemical reactions are expected, or in a place where salt or gases are contained in the air. There is a danger of fire or electric shock.
- Install the printer on a flat, stable desk or table that is free from vibration, in a well-ventilated place.
- Do not install the printer at a location where its operation could be hindered.
- Do not place anything on the printer or leave small objects, like a clip or pin, around it. A foreign object could cause trouble if it gets inside.
- Do not use any sharp-pointed object, such as a pen, for example, to touch the operation panel of the printer. It could cause trouble.
- Do not use the equipment near a radio or TV receiver. Do not share the power from a plug socket a radio or TV receiver is connected to. It may cause a reception problem.
- Use the equipment only at the specified power supply, voltage and frequency. Otherwise, it may emit smoke and catch fire or cause other problems.
- Connect only the specified power source. Use of an unspecified power source could cause trouble or smoke/fire.
- Confirm that a plug socket used for connection has sufficient capacity.
- Avoid connecting a power cable to a plug socket shared by other devices or extending the wiring too far. It may result in the cable catching fire or a power outage. Also, do not step on or apply an excessive force (Pull, Load) to the cable, and do not use the printer with such a force applied to it.
- Never connect a grounding cable (Frame ground) to a gas pipe. There is a danger of explosion. When connecting or disconnecting the grounding cable, be sure to disconnect the power cable and the power plug from the plug socket.
- When connecting/disconnecting the cables, be sure to turn off the power first, including the connected side, and then connect/disconnect them, holding a plug and a connector. Pulling the cable itself could cause it to snap or become damaged.
- Connect a power cable or a connector cable securely. If a reverse-polarity connection is made, internal elements may be broken or a mating device may be adversely affected.

- Use a shielding wire or twisted pair wire for a signal line, in order to minimize noise effect. Do not route the cable too long or connect it to a noisy device. Connection to a noisy device could cause erroneous printing due to corrupt data, and so on.
- Use the equipment in an environment where there is a plug socket near the main body and you can easily disconnect the power plug from it, to shut off the power.
- When the equipment will not be used for a long period of time, unplug it and remove the paper roll from it.
- When transporting the equipment, remove the paper roll from paper holder.

PRECAUTIONS FOR HANDLING

Do not handle the equipment in the following manners, because problems may result.

- Do not use any other power source besides the accessory AC adapter. Also, do not use the AC adapter for other purposes.
- Do not print without paper.
- Do not drop or put any foreign object, such as a clip, pin, or the like, inside the printer.
- Do not spill any liquid or spray any chemical-containing liquid over the equipment.
- Never use a pointed object, such as a pen, to operate the operation panel.
- Do not use Scotch tape to fasten paper together for continuous use. It could damage the printing head.
- Never pull the set paper forcibly. When opening/closing the printer cover, take care that the paper will not be caught. It could cause the paper to jam.
- Be sure to use the specified paper. Use of other paper could deteriorate the print quality or cause a problem with the printing head.

To Prevent and Spreading of Damage

- Never touch the printing head motor, or paper cutting blade. Your finger may be cut.
- During power-on or immediately after printing, do not touch electrical parts or moving parts, such as the mechanism, motor, internal gear, etc. They may be very hot and can burn your hand/finger.
- Be careful to avoid bodily injury or damaging other objects with an edge of sheet metal.
- Should any error occur while operating the equipment, stop it immediately and disconnect the power plug from the plug socket.
- Only a qualified serviceman is allowed to disassemble or repair the printer.
- Should a problem occur, leave solving it to our serviceman. Do not disassemble the equipment on your own.
- When opening/closing the printer cover, and so on, be careful not to catch your hand or finger on the equipment.
- After using the equipment, turn off the power switch and unplug the AC adapter from a plug socket.

DAILY MAINTENANCE

- At the time of maintenance, be sure to turn off the power switch of the printer and unplug it from the socket.
- Use a dry soft cloth to wipe off stains and dust from the surfaces of the main body case. For severe soiling, dip the cloth in water and wring it, for wiping off the soil. Never use organic solvents, such as alcohol, thinner, trichlene, benzene, ketone, or chemical dusters.
- If the equipment is contaminated with paper powder, use a soft brush to clean it. Be careful not to damage the printing head.
- Cleaning the Printing Head
 1. Referring to „Removing Paper Jam“, detach the platen roller unit.
 2. Moisten gauze slightly with alcohol, and clean the heating surface of the printing head with it.
 3. Reattach the platen roller unit.

CAUTION

The printing head and motor are very hot. Be careful not to touch them immediately after printing. Do not touch the heating surface of the head with a bare hand or metal. When detaching or reattaching the platen roller unit, be sure to raise up the printing head, otherwise, they could be damaged. Handle the detached platen roller unit carefully so as not to damage it.

1. OUTLINE

The EP-50 is a compact-sized, line thermal printer developed for variety of applications. It can be used as a data communication terminal, POS terminal, kitchen terminal, etc.

1.1 Features

It can be used in variety of applications because:

- It is compact and light
- The thermal printing mechanism combines both high speed and low noise printing
- It has high exploitation reliability due to the mechanical endurance of the thermal printing head
- Prints variety of barcodes
- There is an independent power supply (AC adapter)

1.2 Unpacking

When unpacking the package, confirm that the following parts are provided:

- Printer body 1 unit
- Sample paper roll 1 roll
- AC adapter 1 piece
- User's manual 1 copy
- Disc 1 piece

CAUTION

- Install the printer body on a flat and stable desk or mount it onto the wall, etc., using a hook, etc.
- Do not install the printer near a heater or in a place exposed to the direct sunshine.
- Do not use the printer in a high-temperature, high-humidity, or contaminated environment.
- Do not allow dew condensation to form on the printer. If such condensation should form, do not turn on the power until it has completely gone away.
- Use only the accessory AC adapter. Do not use it for any other purpose.
- If you do not use the printer for a long period, disconnect the power cable from the socket.
- Keep this manual carefully at hand for ready reference.

2. BASIC SPECIFICATIONS

2.1 Basic specifications

Printing system	Line thermal dot printing
Printing width	48 mm (384 dots/line)
Dot density	8 dots/mm (Width, Length)
Paper feed pitch	0.125 mm
Printing speed	up to 50 mm/s
Character size	12×24, 9×16, 24×24 (only for asian versions)
Character types	Alphanumerals, symbols, international characters (Choose from 20 countries)
Barcode type	UPC-A/E, JAN(EAN) 13-/8-column, ITF, CODE 39, CODE 93, CODE 128, CODABAR, PDF417
Paper	Thermal paper roll: 58 + 0/- 1 mm × φ 83 (max) mm, 60~75 μm thick Thermal label paper: 58 + 0/- 1 mm × φ 83 (max), 150 μm thick (max) (L and M Spec. only) Label width: 56 mm (max) Label length: 25 mm/sh. (min)
Interface	Serial (RS-232C), Parallel (CENTRONICS compliant)
Input buffer	16 KB
Download characters	To downloaded fonts: 12×24, 9×16
AC adapter	Rated input : 100~240 V, 50/60 Hz, 40 VA Rated output : 12 V DC, 2.5 A
Power consumption	At non-printing: Approx. 2 W At printing: Approx. 15 W (approx. 20 W at maximum)
Weight	Main body: Approx. 600 g (Paper roll excluded) AC adapter: Approx. 350 g
Outer dimensions	106 (W) × 184 (D) × 110 (H) mm
Operating temperature and humidity	5~40°C, 35~85 % RH (No dew condensation)
Storage temperature and humidity	-20~60°C, 10~90% RH (No dew condensation)
Reliability	Printing head life: (25°C) Pulse resistance: 50 million pulses or more (Print rate 12.5%) Wear resistance: 50 km or more (With recommended thermal paper at normal temperature and humidity)

2.2 Paper Specifications

2.2.1 Recommended Paper

- Thermal paper roll
- Type: Thermal paper
- Paper width: 58 + 0/-1 mm
- Paper thickness: 60~75µm
- Roll diameter: ϕ 83 mm or less
- Printing surface: Outside of the roll (Surface)
- Recommended paper: TF50KS-E2C (Monochrome) made by NIPPON SEISHI or its equivalent 735FA (2-color, Black based) made by RICOH or its equivalent PB670 (2-color, Red based) made by MITSUBISHI SEISHI or its equivalent
- Core: ϕ 12 mm (Inner dia.), ϕ 18 mm (Outer dia.)

CAUTION

- Use of non-specified paper may cause irregularity of print density.
- Do not paste the paper to the core.
- If the paper comes in contact with a chemical or oil, it may discolor or lose a record.
- Do not rub the paper surface strongly with a nail or hard metal. It may discolor.
- Discoloring starts at about 70°C. Watch out for effects of heat, humidity, light, and so on.
- Do not use the label paper when the printer has been set for thermal paper, and vice versa. Be careful not to mistake a type of label paper. It could cause malfunctioning or damage the printing head.

2.2.2 Recommended Paper

Thermal paper

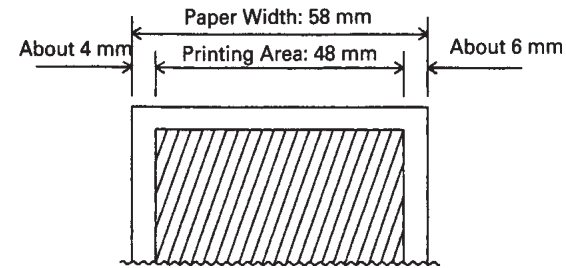

2.2.3 Printing Head and Paper Cutter Layout

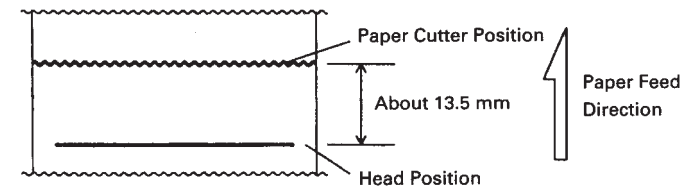

3. OUTER APPEARANCE AND COMPONENT PARTS

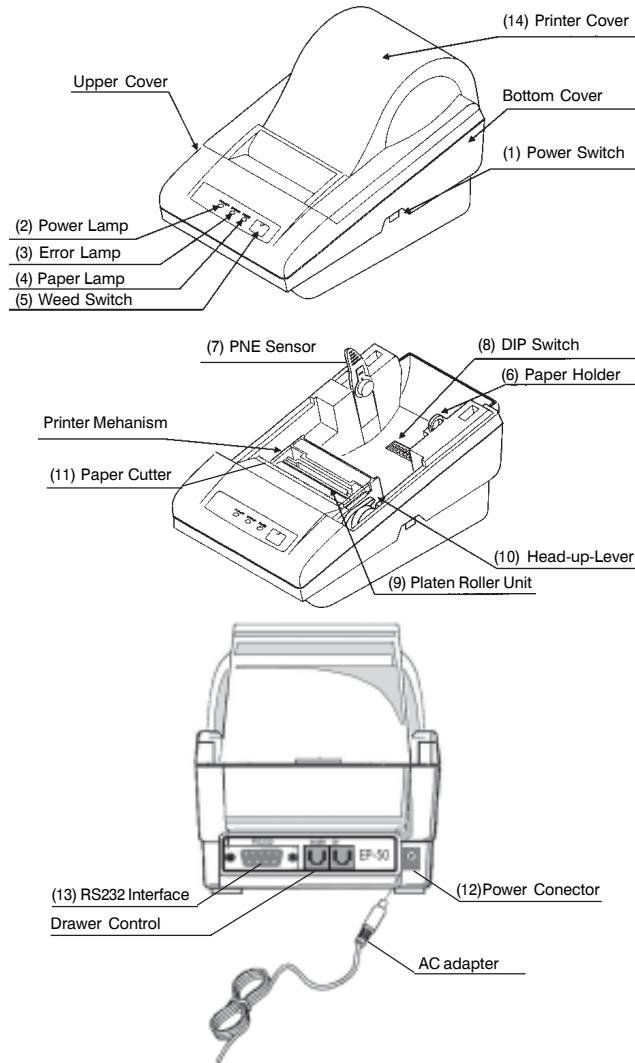

- (1) POWER switch
Turns on/off the power for the printer body.
- (2) POWERlamp
Lights green when the printer is switched on
- (3) ERRORlamp
Flashes red when the printing head is overheated.
- (4) PAPERlamp
Flashes red when the printer is out of paper, lights red constantly if the paper is put, but the lever is not pushed down.
- (5) FEED switch (Button LF)
Feeds the paper. It is fed continuously while the switch is held down.
- (6) Paper holder
Set the paper roll in this holder.
- (7) PNE sensor
Detects that the paper is running out.
- (8) DIP switch
Initially sets the printer at power-on and sets the functions.
- (9) Platen roller unit
Detach this unit when the paper is jamming or when you clean the head.
- (10) Head-up lever
Used when replacing the paper or detaching/reattaching the platen roller unit.
- (11) Paper cutter
Cuts the printed paper.
- (12) Power connector
Connects to the accessory AC adapter.
- (13) Interface connector
Connects to a communication interface cable.
- (14) Printer cover
Detach this cover when replacing the paper.

4. OPERATION

4.1 Connecting AC Adapter

- 1 Turn off the power.
- 2 Connect the cable connector of the AC adapter to the power connector located on the back of the printer.
- 3 Connect the AC power cord of the AC adapter, and plug it into a socket.



CAUTION

- Use only the specified AC adapter.
- When disconnecting/reconnecting the cable connector of the AC adapter, be sure to hold the connector.
- Separate the AC adapter from other noise-generating devices.
- Pulling the AC power cord may damage it, resulting in a fire, electric shock, or snapping.
- If a thunder/lightning storm is nearby, disconnect the AC adapter from the socket and do not use the printer, because a fire or electric shock may occur.
- Do not put the AC power cord close to a heating device. Its coating can melt and cause a fire or electric shock.
- Install the printer in a well-ventilated place, because the AC adapter generates heat when it is used.
- Use the specified AC power source. Connect to a power source with sufficient capacity. If the capacity is insufficient, a fire may result from heat generation.
- After using the printer or when not using it for a long period of time, be sure to unplug the AC adapter from a plug socket for your safety.

4.2 Connecting Interface Cable

- 1 Turn off the power. (Mating side included)
- 2 Check the top and bottom of cable terminals, and connect to the interface connector.
- 3 Connect the cable to the host computer.

4.3 Inserting the Paper

CAUTION

- Be sure to use the specified paper roll.
- Use of non-specified paper may not guarantee the print quality, printing head life, and so on.

- 1 Hold the convexity on the rear of the printer cover, and raise it upward.
- 2 Cut the front end of the paper roll almost at a right angle.
- 3 Make sure that the power is turned on.
- 4 Pull the head-up level to this side to raise up the printing head.
- 5 If there is still some paper remaining after a paper-out indication, eliminate the paper roll according to "4.8 How to Remove Remaining Paper Roll."
- 6 Insert the front end of the paper roll straight into a paper insertion slot.
- 7 Set the paper roll firmly in the paper holder.
- 8 Put back the head-up lever. The paper roll is automatically pulled in by the platen roller to feed a constant amount of paper. (When auto-loading is enabled.)
- 9 Put back the printer cover.



CAUTION

- The printer cover is not stationary (Opening/Closing). After detaching it, be careful not to lose or break it
- Do not insert a ragged or dog-eared end of the paper roll, because it could result in a paper jam or insertion error.

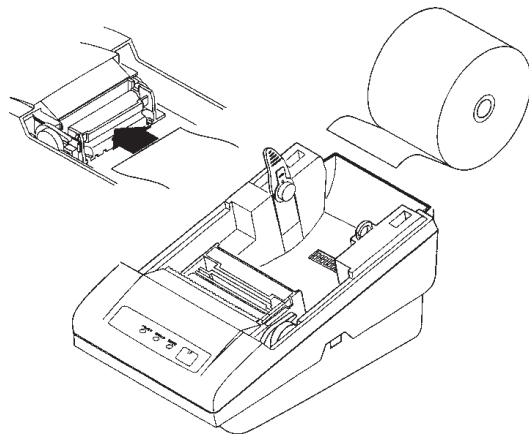

CAUTION

- If the paper roll is still slack, rewind the paper to remove the slack
- If the paper roll is tilted, raise the head-up lever to correct the paper roll position, or pull out the paper roll and set it again.
- Do not open the printer cover while printing.
- Do not hold or press the paper roll while printing, because it could cause a paper jam.
- After the paper is set, the printer is made ready to start printing. Note that if data is remaining in the buffer, the printer will start printing after the paper is set.
- Do not run the printer with its cover removed, because it could cause malfunctioning or an irregularity of the sensor.

4.4 Eliminating the Paper Jam

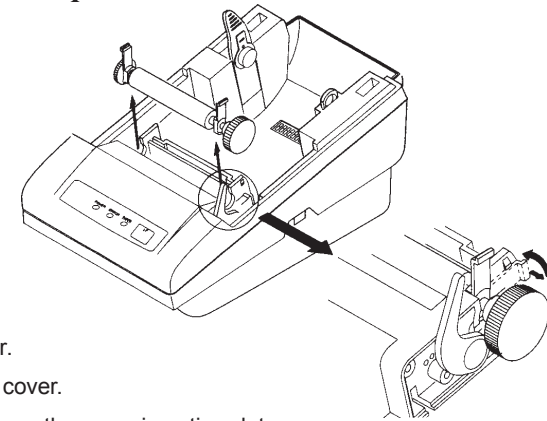

- 1 Turn off the power.
- 2 Detach the printer cover.
- 3 Cut the paper roll near the paper insertion slot.
- 4 Raise the head-up lever.
- 5 Raise the blue levers located on both sides of the platen roller unit, to gently detach the unit. The platen roller unit can be detached by manually raising the blue levers.
- 6 Remove the remaining paper roll completely from the paper passage.
- 7 Confirming the direction of the platen roller unit, reattach it to the mechanism. Shift down the blue levers on both sides, to fix the unit.
- 8 Lower the head-up lever.

CAUTION

- Do not carry out this work just after printing because the printing head is very hot.
- Be sure to turn off the power when detaching the platen roller unit.
- When eliminating remaining paper, do not touch the heating surface of the head with a bare hand or metal piece.
- Do not detach the platen roller unit unless necessary, such as for a paper jam.
- When putting back the platen roller unit, be sure to confirm that it is correctly reattached.
- Never detach or reattach the platen roller unit with the head-up lever lowered.

4.5 LEDs

- POWER** Lights green when the printer is switched on.
- ERROR** Flashes red when the printing head is overheated.
- PAPER** Flashes red when the printer is out of paper, lights red constantly if the paper is put, but the lever is not pushed down.

4.6 FEED Switch Function

- ✓ Pressing this button feeds the paper until it is released.
- ✓ The button must be pressed to continue printing after out of paper error.
- ✓ If a manual macro execution is selected the button must be pressed for each macro execution.
- ✓ Holding down the button while the printer is switched on prints the self test when the button is released.

4.7 Paper End Function

After replacing the paper the printer will resume printing after the Line Feed buttons pressed once. Replace the paper according to "4.3 Inserting the Paper."

4.8 How to Remove Remaining Paper Roll

- 1 Remove the printer cover.
- 2 Raiser the head-up lever.
- 3 Gently pull out the paper to the near side. If the paper roll is still remaining, cut it just before the paper insertion slot before pulling it out.

CAUTION

- Do not pull out the paper roll in the opposite direction.
- Never take out paper with the head-up lever lowered, because it could damage the printing head.
- The printer mechanism may be very hot just after printing, so be duly careful.

5. DIP SWITCH SETTING

5.1 Location of DIP Switch

- 1 Turn off the power.
- 2 Detach the printer cover, and take out the paper roll. (The switch is ound under the paper roll.)
- 3 There is 1 DIP switch (8-pole) for the serial interface.

5.2 DIP Switch Function

Sw1	Sw2	Sw3	Baud rate (bps)
OFF	OFF	OFF	1200
ON	OFF	OFF	2400
OFF	ON	OFF	4800
ON	ON	OFF	9600
OFF	OFF	ON	19200
ON	OFF	ON	38400
OFF	ON	ON	57600
ON	ON	ON	115200

	OFF	ON
Sw4	Hardware protocol	XON / XOFF protocol
Sw5	Standard commands	Extended commands

Sw6	Sw7	Sw8	Code page
OFF	OFF	OFF	Uses the flash setting, ESC t enabled
OFF	OFF	ON	USA CP437
OFF	ON	OFF	Bulgarian CP856
OFF	ON	ON	Russian CP866
ON	OFF	OFF	Latvian
ON	OFF	ON	Lithuanian
ON	ON	OFF	Polish
ON	ON	ON	Uses the flash setting, ESC t disabled



If the code table is selected using the DIP switches, **ESC t** command is disabled and the code table cannot be changed by a command.



In the chinese version of the printer only **Sw8** is defined for changing the code table:

Sw6	Sw7	Sw8	Code page
N/A		OFF	USA CP437
N/A		ON	Chinese GB2312

6. SERIAL INTERFACE CABLE ATTACHMENT

Turn off the printer before attaching the cable. After connecting the connectors screw the two screws.

6.1 Serial Interface

Baud rate	1200, 2400, 4800, 9600, 19200, 38400, 57600, 115200 bps
Serial port parameters	1 start bit, 8 data bits, 1 stop bit, no parity
Signal characteristics	RS232C Mark - logical 1 (-3V □□ -12V) Space - logical 0 (+3V □□ +12V)
DTR control	RS232C Mark - Data transfer disabled Space - Data transfer enabled

6.2 Input-output Signals

RD	Serial input data signal
TD	Serial output data signal
DTR	Reception control signal
GND	Ground

6.3 Signal Description

1 Start bit

One "Space" level bit. Indicates the beginning of data byte.

2 Data bits

Eight consequent bits. First is the least significant bit.

3 Stop bit

One "Mark" level bit. Indicates the end of the byte.

6.4 Dataflow Control

If a hardware protocol is selected the computer could send data only at "Space" level on the **DTR** line. Data reception is disabled when the buffer is close to its upper limit. Reception is re-enabled when the number of bytes in the buffer is below some limit.

If a software (XON/XOFF) protocol is selected the printer sends special control characters – XON (11h) to enable and XOFF (13h) to disable transmission.

7. POWER CONNECTOR

This connector is to supply the power from the special AC adapter (DATECS PS).
Connector Schematic

No.	Function
1	12V
2	GND

Jack used: HEC0470-01-640 (HOSHIDEN) or its equivalent
Applicable plug: JXP series type A (I.D.: 2.45 mm, O.D.: 5.5 mm) (HOSHIDEN) or its equivalent

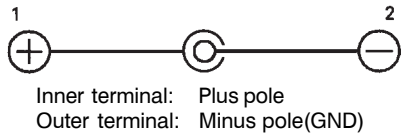

⚠ CAUTION

Inner terminal: Plus pole:

- Be sure to use the specified AC adapter. Use of any other power source could cause trouble to or break the printer.
- Do not connect the power source with different polarity.
- After using the printer or when not using it for a long period of time, be sure to unplug the AC adapter from a plug socket for your safety.

8. COMMAND LIST

1	BEL	Sounds the beeper	07H
2	HT	Horizontal tab command	09H
3	LF	Printing and paper feed	0AH
4	CR	Print command	0DH
5	ESC RS	Sounds the beeper	1BH 1EH
6	ESC SP	Setting the right space amount of the character	1BH 20H n
7	ESC \$	Specifying the absolute positions	1BH 24H n1 n2
8	ESC %	Selecting user character set	1BH 25H n
9	ESC &	Define user characters	1BH 26H m n1 n2
10	ESC !	Collective specifying printing mode	1BH 21H n
11	ESC *	Specifying the bit image mode	1BH 2AH m n1n2[d]k
12	ESC -	Specifying/cancelling underline	1BH 2DH n
13	ESC .	Self test / demo	
14	ESC ,	Printing diagnostic information	1BH 54H
15	ESC 2	Specifying 1/6-inch line feed rate	1BH 32H
16	ESC 3	Setting line feed rate of minimum pitch	1BH 33H n
17	ESC =	Data input control	1BH 3DH n
18	ESC >	Set Factory Defaults	1BH 3EH n
19	ESC @	Initializing the Printer	1BH 40H
20	ESC D	Setting horizontal tab position	1BH 44H [n]k 00H
21	ESC E	Specifying/cancelling highlighting	1BH 45H n
22	ESC G	Specifying/cancelling double printing	1BH 47H n
23	ESC I	Specifying/cancelling italic printing	1BH 49H n
24	ESC J	Printing and feeding paper n/203 inch	1BH 4AH n
25	ESC M	Selecting character font A or B	1BH 4DH n
26	ESC R	Setting the international character set	
27	ESC V	Specifying/canceling 90°-right-turned characters	1BH 56H n
28	ESC X	Select maximal printing speed	
29	ESC Y	Selecting intensity level	1BH 59H n
30	ESC Z	Transmits identification string	1BH 5AH
31	ESC \	Specifying the relative positions	1BH 5CH n1 n2

32	ESC _	Restore factory settings	1BH 5FH
33	ESC '	Transmits current battery voltage and the print head temperature	1BH 60H
34	ESC a	Aligning the characters	1BH 61H n
35	ESC c5	Enabling/disabling the panel switches	1BH 63H 35H n
36	ESC d	Printing and feeding the paper by n lines	1BH 64H n
37	ESC i	Cutting the paper	
38	ESC m	Cutting the paper	
39	ESC p	Generating a drawer-kick pulse	
40	ESC t	Selecting the character code table	
41	ESC v	Transmitting the printer status	1BH 76H n
42	ESC x	Reversing the print direction	1BH 78H n
43	ESC {	Specifying/canceling the inverted characters	1BH 7BH n
44	GS (A	Printing a self-test	
45	GS B	Specifying/canceling the black/white inverted printing	
46	GS C	Reading the real time clock	1DH 43H
47	GS L	Setting the left margin	1DH 4CH n1 n2
48	GS V	Cutting the paper	
49	GS c	Setting the real time clock	1DH 63H
50	GS k	Printing the bar code	1DH 6BH n [d]
51	GS w	Selecting the horizontal size (scale factor) of bar code	1DH 77H n
52	GS h	Selecting the height of the bar code	1DH 68H n
53	GS H	Selecting of print position of HRI code	1DH 48H n
54	GS f	Selecting the font of HRI code	1DH 66H n
55	GS p	Setting bar code PDF-417 parameters	1DH 70H
56	GS v 0	Printing of raster bit image	
57	GS *	Defining the downloaded bit image	1DH2An1n2[d]n1xn2
58	GS /	Printing the downloaded bit image	1DH 2FH m
59	GS :	Starting/ending macro definition	1DH 3AH
60	GS ^	Executing the macro	1DH 5EH n1 n2 n3
61	FS p	Printing the downloaded NV bit image	
62	FS q	Defining the downloaded bit image	

9. DETAILED DESCRIPTION

XXXX ALL

[Function] Command Function

[Code] A sequence of code constituting a command is represented in hexadecimal number for <>H, binary number for <>B, and decimal number for <>, respectively; []k represents a repeat count of k-times.

[Range] Describes an argument value(setting range) for the command.

[Outline] Describes a command outline.

[Caution] Describes a caution as required.

[Default] Describes an initial value for the command when accompanied by an argument.

[See Also] Describes the associated commands for use.

[Sample Program]

Describes a coding example in the Q-BASIC sample program.

* This example is only for your reference and differs depending on the language used, version, and so on. For details, see the manual for the language used.

1. BEL

Sounds the beeper

[Code] **[07h]**

[Outline] Sounds the beeper.

2. HT

Horizontal Tab Command

[Code] **[09h]**

[Outline] Shifts the printing position to the next horizontal tab position.

- Ignored when the next horizontal tab position has not been set.
- The horizontal tab position is set by ESC D.
- Initial setting of the horizontal tab position is each 8 characters in 9th, 17th, 25th, columns.

[See Also] ESCD

[Sample Program]

```
LPRINT "0123456789012345678901";
LPRINT CHR$ (&HA);
LPRINT CHR$ (&H9) + "AAA";
LPRINT CHR$ (&H9) + "BBB";
LPRINT CHR$ (&HA);
LPRINT CHR$ (&H1B) + "D";
LPRINT CHR$ (3) + CHR$ (7) + CHR$ (14) + CHR$ (0);
LPRINT CHR$ (&H9) + "AAA";
LPRINT CHR$ (&H9) + "BBB";
LPRINT CHR$ (&H9) + "CCC" + CHR$ (&HA);
```

[Print Results]

```
0123456789012345678901
   AAA   BBB ← Initially set horizontal tab
AAA BBB   CCC ← When set to the 4th, 8th, and 15th
                columns
```

3. LF

Printing and Paper Feed Command

[Code] **[0Ah]**

[Outline] Prints data inside the input buffer and feeds lines based on the line feed amount having been set. The head of the line becomes the next print starting position.

[See Also] ESC 2, ESC 3

[Sample Program]

```
LPRINT "AAA" + CHR$ (&HA);
LPRINT "BBB" + CHR$ (&HA);
LPRINT CHR$ (&HA);
LPRINT "CCC" + CHR$ (&HA);
```

[Print Results]

```
AAA ← Print and line feed
BBB ← Print and line feed
    ← Line feed only
CCC ← Print and line feed
```

4. CR

Print Command

[Code] **[0Dh]**
This command is ignored.

5. ESC RS

Sounds the beeper

[Code] **[1Bh] + [1Eh]**

[Outline] Sounds the beeper.

6. ESC SP n

Setting the right space amount of the character

[Code] **[1Bh] + [20h] + n**

[Range] {0 ≤ n ≤ 20}

[Outline] The rightward space amount is set in dot unit (1/203 inch unit).

[Caution] The rightward space amount in double width mode is made double of the set volume.

[Default] n = 0

[Sample Program]

```
LPRINT CHR$ (&H1B) + " " + CHR$ (0);
LPRINT "AAAAA" + CHR$ (&HA);
LPRINT CHR$ (&H1B) + " " + CHR$ (1);
LPRINT "AAAAA" + CHR$ (&HA);
LPRINT CHR$ (&H1B) + " " + CHR$ (12);
LPRINT "AAAAA" + CHR$ (&HA);
```

[Print Results]

```
AAAAA ← 0-dot space
AAAAA ← 1-dot space
A A A A A ← 12-dot space
```

7. ESC \$ n1 n2

Specifying the Absolute Positions

[Code] **[1Bh] + [24h] + n1 + n2**

[Range] {0 <= n1 <= FFh}
 {0 <= n2 <= 2}
 {0 <= n1+n2*256 <= 384}

[Outline] The printing start position is specified in the number of dots (1/203 inch unit) from the beginning of line.
 • The number of dots is divided by 256, whose quotient is taken as n2 and the residual as n1.
 • Therefore, the printing start position is equal to n1 + n2 x 256 from the beginning of line.

[Caution] • Specifying beyond the line end is ignored.

[Default] • The initial value is not specified.

[See Also] ESC \

[Sample Program]

```
LPRINT CHR$ (&H1B) + "$";
LPRINT CHR$ (0) + CHR$ (0) + "A";
LPRINT CHR$ (&H1B) + "$";
LPRINT CHR$ (50) + CHR$ (0) + "B";
LPRINT CHR$ (&H1B) + "$";
LPRINT CHR$ (0) + CHR$ (1) + "C";
LPRINT CHR$ (&HA);
LPRINT CHR$ (&H1B) + "$";
LPRINT CHR$ (100) + CHR$ (0) + "A";
LPRINT CHR$ (&H1B) + "&#165;";
LPRINT CHR$ (&HC2) + CHR$ (&HFF) + "B";
LPRINT CHR$ (&HA);
```

[Print Results]

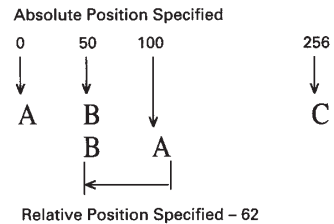

8. ESC % n

Select/cancel user defined characters

[Code] **[1Bh] + [25h] + n**

- Only bit 0 of n is defined
- Value 0: Selected
- Value 1: Not selected

[See also] ESC &

9. ESC & s n1 n2 [a [d] s x a] k

ESC & m n1 n2 [d] k

Define user characters

There are two different types of this command selected by switch 5's position.

If switch 5 is OFF:

[Code] **[1Bh] + [26h] + s + n + m + [a₁ + D₁] + ... + [a_{m-n+1} + D_{m-n+1}]**

[Range] {s = 3}
 {20h <= n <= FFh}
 {n <= m <= FFh}
 {0 <= a <= 12}
 {0 <= D_i <= FFh}

[Outline] Defines a group of downloaded characters where:
 „s“ is the number of bytes in vertical direction – always three.
 „n“ indicates the start character code and „m“ indicates the end character code. To define only one character set n=m.
 „a“ is the number of dots in horizontal direction.
 „D_i“ is the data to be defined. The number of data for each symbol is s x a. Each symbol defines with three bytes of data in vertical direction followed by the next three bytes that define the next one-dot column, etc.

The downloaded font is cleared by ESC @ and ESC _ commands and when the printer is switched off.

[Default] The default downloaded font is equal to the default character set. However the downloaded font is not reset when the code page is changed, thus it remains the same as the previous code page.

If switch 5 is ON:

[Code] **[1Bh] + [26h] + a + n1 + n2 + D1₁ + ... + D_{(m-n+1)k}**

[Range] { m = 0-3 Subcommand }
 { 20h <= n1 <= FFh }
 { n1 <= n2 <= FFh }
 { k = (n2-n1+1)*48 for m=2 and k = (n2-n1+1)*16 for m=3 }

[Outline] Defines a group of user characters.

m=0: Copy internal character set A to user character set A (Parameters n1, n2 and d are omitted)

m=1: Copy internal character set B to user character set B (Parameters n1, n2 and d are omitted)

m=2: Define character group with ASCII codes between >=n1 and <=n2 for character set A (12x24). Every character is 48 bytes, two bytes for each line. Only the first nibble of the second byte is used.

m=3: Define character group with ASCII codes between >=n1 and <=n2 for character set B (9x16). Every character is 16 bytes.

n1 is the ASCII code of the first and **n2** is the ASCII code of the last of (n2-n1+1) consecutive symbols. To define a single symbol n1=n2.

d is the data that defines the symbols. Every Font A symbol consists of 48 bytes while every Font B symbol consists of 16 bytes. A Font A symbol is defined left to right, top to bottom, two bytes for each horizontal line, as only the four most significant bits of the second byte are used. Every bit denotes one dot. A bit set to '1' means black dot. The most significant bit is the starting. Every horizontal line of Font B symbol consists of one byte, as the ninth point is always white. The most significant bit is the starting. The user-defined characters are kept after printer off.

[See Also] ESC %

10. ESC ! n

Collective Specifying Printing Mode

[Code] **[1Bh] + [21h] + n**

[Range] { 0 <= n <= FFh }

[Outline] Printing mode is assigned. Each n bit indicates the following:

Bit	Function	Value 0	Value 1
0	Character Font	Font A	Font B
1		Undefined	
2		Undefined	
3	High-lighting	Canceled	Specified
4	Double height	Canceled	Specified
5	Double width	Canceled	Specified
6		Undefined	
7	Underline	Canceled	Specified

- [Caution]
- With double height and double width being specified simultaneously, double wide and double high characters are consisted.
 - An underline is attached to the full character width, which, however, is not attached to the part having been skipped by the horizontal tab. Neither is it attached to 90°-right-turned characters.
 - The underline width is as having been specified by <ESC ->. (The default setting is 1 dot width)
 - In case that double wide character and normal character exist in same one line, the layout of underline is consistent one.

[Default] n = 0

[See Also] ESC E, ESC -

[Sample Program]

```
LPRINT CHR$(&H1B) + "!" + CHR$(&H00) + "H" ;
LPRINT CHR$(&H1B) + "!" + CHR$(&H01) + "H" ;
LPRINT CHR$(&H1B) + "!" + CHR$(&H08) + "H" ;
LPRINT CHR$(&H1B) + "!" + CHR$(&H10) + "H" ;
LPRINT CHR$(&H1B) + "!" + CHR$(&H20) + "H" ;
LPRINT CHR$(&H1B) + "!" + CHR$(&HB9) + "H" ;
LPRINT CHR$(&HA) ;
END
```

[Print Results]

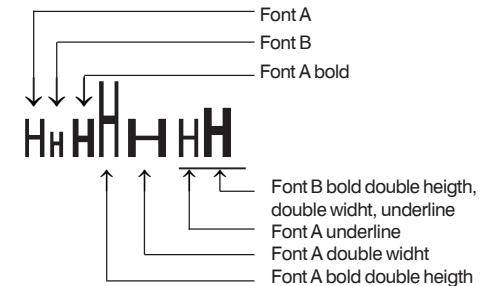

11. ESC * m n1 n2 [d] k

Specifying the Bit Image Mode

[Code] **[1Bh] + [2Ah] + m + n1 + n2 + D₁ + ... + D_k**

[Range] {m = 0, 1, 32, 33 bit image mode (See the table below.)}
 {0 <= n1 <= FFh}
 {0 <= n2 <= 3}
 {0 <= d <= FFh}
 {k = n1 + 256 X n2 (m = 0, 1)}
 {k = (n1+256 X n2) X 3} (m = 32, 33)

[Outline] According to the number of dots specified in n, n2, specify the bit image of mode m.

- The total number of dots printed in the bit image is equal to n1 + (256 x n2).
- When bit image data have been input in excess of dot position of one line (384 dots), the excess data are discarded.
- d is bit image data, the bits subject to printing are taken as "1" and those not as "0".
- The bit image modes specified by m are shown as follows:

		Vertical Direction		Horizontal Direction	
m	Mode	Dots	Dot Density	Dot Density	Max. Dots
0	8-dot single density	8	67 DPI	101 DPI	192
1	8-dot double density	8	67 DPI	203 DPI	384
32	24-dot single density	24	203 DPI	101 DPI	192
33	24-dot double density	24	203 DPI	203 DPI	384

[Caution] • When the values set in m (bit image mode) are out of the above range, the data following after n1 is processed as normal printing data.
 • After completion of bit image printing, printer returns to normal data processing mode.

The command has another variant with four new modes:

ESC * m n [d] k

ESC * m n a f [d] k

Specifying the Bit Image Mode (Sending graphics data horizontally)

[Code] **[1Bh] + [2Ah] + m + n + { a + [00h] } + D₁ + ... + D_k**

[Range] {m = 16, 17, 18, 20 bit image mode }
 {0 <= n <= 40h}
 {0 <= d <= FFh}
 {k = n * 24 * 48} (m = 16)
 {k = n * 24 * 48} (m = 17) { After decompression }
 {k = n * h * 48} (m = 18) { After decompression }
 {k = n * 24 * 48} (m = 20) { After decompression }
 {0 <= a <= 24 (Used only for mode 18.)}
 {f = 0 (Used only for mode 18.)}

[Outline] In these graphics modes is sent a graphics block with variable width n*8 dots and height 24 dots for modes 16,17 and a dots for mode 18. In mode 17 data is compressed, and the bytes count specified is before the compression. In mode 16 the same data is without compression. Mode 20 is similar to mode 17, but every byte is mirrored before putting in the print buffer (bits 0 and 7, 1 and 6, 2 and 5, 3 and 4 change places). All modes are high resolution (203 x 203 DPI).

- When bit image data have been input in excess of dot position of one line (384 dots) , the excess data are discarded.
- d is bit image data, the bits subject to printing are taken as "1" and those not as "0".

[Caution] • When the values set in m (bit image mode) are out of the above range, the data following after n is processed as normal printing data.
 • After completion of bit image printing, printer returns to normal data processing mode.

[Compression procedure for mode 17 and 18]

A simple RLE encoding like this in PCX files is used. If two most significant bits of the byte are set, the 6 LSB contain a repeat counter (1-63), and the next byte contains the data to be repeated. A single data byte with 2 MSB set must be sent as two bytes.

12. ESC – n

Specifying/ Canceling Underline

[Code] **[1Bh] + [2Dh] + n**

[Range] {0 <= n <= 2}

[Outline] Specifying/canceling an underline.

- Types of underlines by n value are shown below:

- 0 Canceling an underline.
- 1 Specifying an underline for 1-dot width.
- 2 Specifying an underline for 2-dots width.

[Caution] • An underline is attached to the full character width. It is, however, not attached to the part having been skipped by horizontal tab command.
 • An underline is not attached to a 90°-right-turned characters.

[See Also] ESC!

[Sample Program]

```
LPRINT CHR$(&H1B) + "-" + CHR$(0);
LPRINT "AAAAA";
LPRINT CHR$(&H1B) + "-" + CHR$(1);
LPRINT "AAAAA" + CHR$(&HA);
END
```

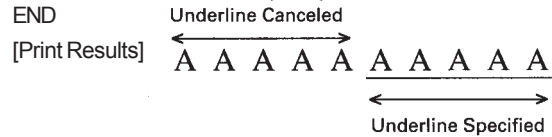

13. ESC .

Selftest.

[Code] **[1Bh] + [2Eh]**

[Outline] Prints character table, character samples with different attributes and diagnostic information.

[See also] ESC,

14. ESC ,

Printing diagnostic information

[Code] **[1Bh] + [2Ch]**

[Outline] Printing current intensity level, temperature, code tables, communication mode, protocol and serial port speed if a serial communication board is installed.

[See also] ESC.

15. ESC 2

Specifying 1/6-inch line feed rate

[Code] **[1Bh] + [32h]**

[Outline] The line feed rate per line is specified by 1/6 inch.

[Sample Program]

```
LPRINT "AAAAA" + CHR$ (&HA);
LPRINT CHR$ (&H1B) + "3" + CHR$ (0);
LPRINT "AAAAA" + CHR$ (&HA);
LPRINT CHR$ (&H1B) + "3" + CHR$ (50);
LPRINT "AAAAA" + CHR$ (&HA);
LPRINT CHR$ (&H1B) + "2";
LPRINT "AAAAA" + CHR$ (&HA);
LPRINT "AAAAA";
LPRINT CHR$ (&H1B) + "J" + CHR$ (100);
LPRINT "AAAAA" + CHR$ (&HA);
LPRINT "AAAAA" + CHR$ (&HA);
```

[Print Results]

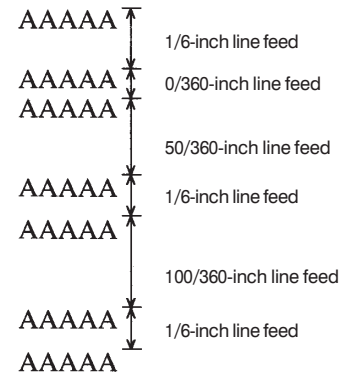

16. ESC 3 n

Setting line feed rate of minimum pitch

[Code] **[1Bh] + [33h] + n**

[Range] {0 <= n <= FFh}

[Outline] The line feed rate per line is specified by n/203 inch.

[Default] The initial value is n = 34 (1/6 inch) (22H), being 4.23 mm line feed rate.

17. ESC = n

Data Input Control

[Code] **[1Bh] + [3D] + n**

[Range] {0 <= n <= FFh}

[Outline] Selecting equipment in which data input from the host is effective.

- Only bit 0 is defined
Value 0: Selected
Value 1: Not selected
- When the printer has not been selected, this printer abandons all the received data until it is selected by this command.

[Caution] • Even when the printer has not been selected, it can become BUSY state through printer operation.
• When the printer is deselected, this printer discards all the data until it is selected with this command.

[Default] • The initial value of n is "1".

[Sample Program]

```
LPRINT "AAAAA";
LPRINT CHR$ (&H1B) + "=" + CHR$ (0);
LPRINT "aaaaa" + CHR$ (&HA);
LPRINT CHR$ (&H1B) + "=" + CHR$ (1);
LPRINT "AAAAA" + CHR$ (&HA);
```

[Print Results]

```

A A A A C C C C C
  ↑
  AAAAA is not printed
```

18. ESC > n

Set Factory Defaults

[Code] **[1Bh] + [3Eh] + n**

[Range] {0 <= n <= FFh}

[Outline] This command writes the current code tables, the intensity level and the current printing speed into the flash memory. These values will be retrieved at first power up or after a power failure.

- Value of n doesn't matter. It is left for compatibility purpose.

[Default] • The initial values are: code tables 0 (US American CP437), intensity level 100%, maximum printing speed.

19. ESC @

Restore saved to nonvolatile RAM settings

[Code] **[1Bh] + [40h]**

[Outline] Clears data stored in the print buffer and brings various settings to the initial state.

[Caution] • Data inside the internal input buffer are not cleared.
• The current code tables, print intensity and printing speed are not reset.
• If switch 5 is OFF, the command clears the downloaded font and bit image too.

[See also] ESC ^ and ESC _

[Sample Program]

```
LPRINT CHR$ (&H1B) + "!" + CHR$ (&H30);
LPRINT CHR$ (&H1B) + "V" + CHR$ (1);
LPRINT "AAA" + CHR$ (&HA);
LPRINT CHR$ (&H1B) + "@";
LPRINT "AAA" + CHR$ (&HA);
```

[Print Results]

```

V V V
```

AAA ← Each setting has been initialized by the reset command.

20. ESC D [n] k NUL

Setting Horizontal Tab Position

[Code] **[1Bh] + [44h] + n₁ + ... + n_k + [00h]**

[Range] {0 <= n <= FFh}
{0 <= k <= 20h}.

- [Outline] Specifying a horizontal tab position.
- "n" indicates the no. of columns from the beginning to the horizontal tab position. At this time, n= set position 1 is to be specified. For example, to set the position at 9th column, n=8 is to be specified.
 - k denotes the number of horizontal tab positions you want to set.
 - The tab position is set at position where it is "character width x n" from the line beginning. The character width, at this time, includes the rightward space amount. In double wide characters, it is made double of the ordinary case.
 - Tab positions can be specified are maximum 32. Specifying exceeding this is ignored.
 - <n> k, which denotes a setting position, is input in the increasing order and ends at <00>H.
 - ESC D NUL clears all the set tab positions. Following clearing, horizontal tab command is ignored.

[Caution] When the data, <n> k, is equal to or smaller than its preceding data, <n>k-1, it is assumed that tab setting is finished. If this is the case, the next data onward will be processed as normal data. When the data, <n> k, exceeds a 1-line print area, set the horizontal tab position, assuming "Set digit position = Maximum print digits + 1." The horizontal tab position does not change even if the character width is altered after setting the horizontal tab position.

[Default] • Initial value is specified for each eight characters (9 th .17 th .25 th column).

[See Also] HT

21. ESC E n

Specifying/canceling highlighting

[Code] **[1Bh] + [45h] + n**

[Range] {0 <= n <= FFh}

- [Outline] Specifying/canceling the highlighting characters.
- "n" is valid only for the lowest bit (n0).
 - Control by the lowest bit (n0) is shown as follows:
 - 0 Canceling highlighting.
 - 1 Specifying highlighting.
 - This is effective to all characters of font A.
 - Characters of font B are not highlighted.
 - Dot configuration of a highlighted character includes one extra dot added at its side.

[Caution] • The print result of Double printing and highlight character printing is completely same.

[See Also] ESC!

[Sample Program]

```
LPRINT CHR$ (&H1B) + "E" + CHR$ (0);
LPRINT "AAABBB" + CHR$ (&HA);
LPRINT CHR$ (&H1B) + "E" + CHR$ (1);
LPRINT "AAABBB" + CHR$ (&HA);
```

[Print Results]

A A A B B B ← Highlighting canceled

A A A B B B ← Highlighting specified

22. ESC G n

Specifying/canceling Double Printing (ESC G n)

[Code] **[1Bh] + [47h] + n**

[Range] {0 <= n <= FFh}

[Outline] Specifying/canceling the double printing.

- "n" is valid only for the lowest bit (n0).
- Control by n is shown as follows.
 - 0** Canceling double printing.
 - 1** Specifying double printing.
- This is effective to all characters of font A.
- Characters of font B are not highlighted.

[Caution] • The print result of Double printing and highlight character printing is completely same.

[See Also] ESC E

[Sample Program]

```
LPRINT CHR$ (&H1B) + "G" + CHR$ (0);
LPRINT "AAABBB" + CHR$ (&HA);
LPRINT CHR$ (&H1B) + "G" + CHR$ (1);
LPRINT "AAABBB" + CHR$ (&HA);
```

[Print Results]

A A A B B B ← Highlighting canceled

A A A B B B ← Highlighting specified

23. ESC I n

Specifying/canceling italic printing (ESC I n)

[Code] **[1Bh] + [49h] + n**

[Range] {0 <= n <= FFh}

[Outline] Specifying/canceling the double printing.

- "n" is valid only for the lowest bit (n0).
- Control by n is shown as follows.
 - 0** Canceling italic printing.
 - 1** Specifying italic printing.

[Sample Program]

```
LPRINT CHR$(&H1B) + "I" + CHR$(0);
LPRINT "BBBBB";
LPRINT CHR$(&H1B) + "I" + CHR$(1);
LPRINT "BBBBB";
```

[Print Results]

BBBBBBBBBB

24. ESC J n

Printing and feeding paper n/203 inch

[Code] **[1Bh] + [4Ah] + n**

[Range] {0 <= n <= FFh}

[Outline] Prints data inside the print buffer and feeds paper by n/203 inch. Since an actual mechanical pitch is 1/203 inch, it is internally converted approximate to the value specified with this command.

- Specified volume does not remain.
- The beginning of the line is to be considered as the next printing start position.
- Initial value is not defined.

25. ESC M n

Specifying/canceling highlighting

[Code] **[1Bh] + [4Dh] + n**

[Range] {0 <= n <= FFh}

[Outline] Selects character font.

- "n" is valid only for the lowest bit (n0).
- Control by the lowest bit (n0) is shown as follows:
 - 0 Selection of font A (12x24).
 - 1 Selection of font B (9x16).

[Caution] ESC ! can also select fonts, but the setting made by the command processed last is valid.

[See also] ESC !

[Sample Program]

```
LPRINT CHR$(&H1B) + "M" + CHR$(0);
LPRINT "AAAAA";
LPRINT CHR$(&H1B) + "M" + CHR$(1);
LPRINT "AAAAA";
```

[Print Results]

AAAAA_AAAAA

26. ESC R n

Selecting international character set

[Code] **[1Bh] + [52h] + n**

[Range] {0 <= n <= 10}

[Outline] Depending on the value of „n“, one of the following character sets is selected:

n	Country	Character Set											
		23h	24h	40h	5Bh	5Ch	5Dh	5Eh	60h	7Bh	7Ch	7Dh	7Eh
0	U.S.A.	#	\$	@	[\]	^	`	{		}	~
1	France	#	\$	à	°	€	§	^	`	é	ù	è	~
2	Germany	#	\$	§	Ä	Ö	Ü	^	`	ä	ö	ü	ß
3	U.K.	£	\$	@	[\]	^	`	{		}	~
4	Denmark I	#	\$	@	Æ	Ø	Å	^	`	æ	ø	å	~
5	Sweden	#	\$	É	Ä	Ö	Å	Ü	é	ä	ö	å	ü
6	Italy	#	\$	@	°	\	é	^	ù	à	ò	è	ì
7	Spain I	Pt	\$	@	ı	Ñ	ı	^	`	ñ	ı	ı	~
8	Japan	#	\$	@	[¥]	^	`	{		}	~
9	Norway	#	□	É	Æ	Ø	Å	Ü	é	æ	ø	å	ü
10	Denmark II	#	\$	É	Æ	Ø	Å	Ü	é	æ	ø	å	ü

27. ESC V n

Specifying/Canceling 90e -right- turned Characters

[Code] **[1Bh] + [56h] + n**

[Range] {0 <= n <= 1}.

[Outline] Specifying/canceling characters 90e -right- turned character.

- "n" means the followings.
 - 0 Canceling 90e -right- turned Characters
 - 1 Specifying 90e -right- turned Characters

[Caution] • No underlines are attached to 90e -right- turned characters .

[Default] • The initial value of n is "0".

[Sample Program]

```
LPRINT CHR$ (&H1B) + "V" + CHR$ (0);
LPRINT "AAAAA";
LPRINT CHR$ (&H1B) + "V" + CHR$ (1);
LPRINT "AAAAA" + CHR$ (&HA);
```

[Print Results]

90° Rotation Canceled
 AAAAA
 90° Rotation Specified

28. ESC X n

Select maximum printing speed

[Code] **[1Bh] + [58h] + n**

[Range] {0 <= n <= 3}
 {'0' <= n <= '3'}

[Outline] Selects the maximum printing speed according to the value of 'n':
 0 or '0' about 50 mm/s
 1 or '1' about 42 mm/s
 2 or '2' about 33 mm/s
 3 or '3' about 25 mm/s
 These values are approximate. The real maximum speed depends on the print intensity and the printing head's temperature.

[Default] The default value is 0 – maximal printing speed.

29. ESC Y n

Selecting the intensity level

[Code] **[1Bh] + [59h] + n**

[Range] {0 <= n <= 5}

[Outline] Set the intensity level.

- “n” means the followings.

- 0** Set intensity 70 %

- 1** Set intensity 80 %

- 2** Set intensity 90 %

- 3** Set intensity 100 %

- 4** Set intensity 120 %

- 5** Set intensity 150 %

[Caution] • Higher intensities can cause a lower speed.

[Default] • The initial value of n is 3.

[Sample Program]

```
LPRINT CHR$ (&H1B) + "Y" + CHR$ (0);
```

```
LPRINT "AAAAA";
```

```
LPRINT CHR$ (&H1B) + "Y" + CHR$ (5);
```

```
LPRINT "AAAAA" + CHR$ (&HA);
```

30. ESC Z

Transmits identification string.

[Code] **[1Bh] + [5Ah]**

[Outline] The printer transmits 32 bytes of information with the following structure:

1 – 22: Printer name complemented with space up to 22 symbols.

23 – 25: Firmware version – 3 digits (in ASCII format).

26 – 26: Language version – 2 letters.

28 – 32: 5 bytes flags. Each bit describes a printer feature, as '1' means that the feature is present, while '0' means its absence. Bits are described as follows:

Bit	Meaning
28.0	Supports IrDA mode
28.1	Supports magnetic card reader
28.2	Supports simultaneous reading of three tracks from a magnetic card
28.3	ASCII codes above 127 contain Katakana symbols
28.4	Supports JIS and Shift-JIS symbols
28.5	Prints when ESC . and ESC T, and transmits when ESC ' the temperature in ° Fahrenheit
28.6	Not Used
28.7	Reserved – always 1
29.0	Supports downloadable fonts and firmware
29.1	Korean support
29.2	Black mark support
29.3	Barcode reader support
29.4	USB A installed
29.5	USB B installed
29.6	Not Used
29.7	Reserved – always 1
30.0	Not Used
30.1	Not Used
30.2	Not Used
30.3	Not Used
30.4	Not Used
30.5	Not Used
30.6	Not Used
30.7	Reserved – always 1
31.0	Not Used
31.1	Not Used
31.2	Not Used
31.3	Not Used
31.4	Not Used
31.5	Not Used

31.6	Not Used
31.7	Reserved – always 1
32.0	Not Used
32.1	Not Used
32.2	Not Used
32.3	Not Used
32.4	Not Used
32.5	Not Used
32.6	Not Used
32.7	Reserved – always 1

31. ESC \ n1 n2

Specifying the Relative Positions

[Code] **[1Bh] + [5Ch] + n1 + n2**

[Range] {0 <= n1 <= FFh}
{0 <= n2 <= FFh}

[Outline] The printing start position is specified in the number of dots (1/203 inch unit) from the current position.

- Rightward direction is taken as plus and leftward direction as minus.
- To specify N dot in minus (left) direction, use a complement of N for assignment.
– N dots = 65536 – N
- The number of dots is divided by 256, whose quotient is taken as n2 and the residual as n1.
- There are 384 dots per line (positions from 0 to 383).

[Caution] • Specifying exceeding the beginning of the line or the end of the line ignored.

[Default] • The initial value is not specified.

[See Also] ESC\$

32. ESC _

Restore factory defaults and save them to nonvolatile RAM

[Code] **[1Bh] + [5Fh]**

[Outline] Select font A, no bold, no underline, etc. Restore tab defaults. The parameters are read from the flash memory. Downloaded font and downloaded bit image are cleared. Copy internal fonts A and B to user fonts. DIP switches are read again. Data in the input buffer is not cleared.

[See also] ESC@

33. ESC ‘

Transmits the current power supply voltage and the print head temperature.

[Code] **<1B>H<60>H**

[Outline] The printer transmits two bytes data. First byte is the power supply voltage given as 0.1 mV plus 20h. the second byte is the print head temperature, in degrees Celsius, plus 20h.

[Example] **If the battery voltage is 6.4 V, and the print head temperature is 33°C, the printer will transmit <60h><41h>, which is <40h+20h><21h+20h> or <64+32><33+32>.**

34. ESC a n

Aligning the characters

[Code] **[1Bh] + [61h] + n**

[Range] {0 <= n <= 2}
{4 <= n <= 6 }

[Outline] This command is extended and has the following format: All the printed text data, the barcode or the raster bit image (GS v0) within one line are aligned in the specified position. If used before printing a barcode with this command can be specified vertical direction for printing the barcode.

- Depending on **n** value, positional alignment is carried out as in the table below:

- 0** Left end alignment
- 1** Centering
- 2** Right end alignment
- 4** Left end aligned vertical barcode
- 5** Centered vertical barcode
- 6** Right end aligned vertical barcode

[Default] • The initial value of **n** is "0".

[Sample Program]

```
LPRINT CHR$ (&H1B) + "a" + CHR$ (0);
LPRINT "AAAAA" + CHR$ (&HA);
LPRINT CHR$ (&H1B) + "a" + CHR$ (1);
LPRINT "AAAAA" + CHR$ (&HA);
LPRINT CHR$ (&H1B) + "a" + CHR$ (2);
LPRINT "AAAAA" + CHR$ (&HA);
```

[Print Results]

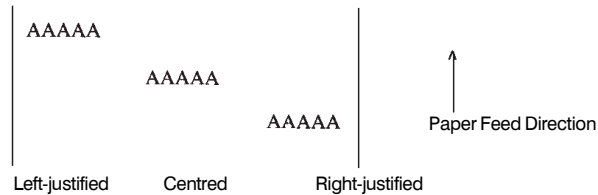

35. ESC c5 n

Enabling/Disabling Panel Switches

[Code] **[1Bh] + [63h] + [35h] + n**

[Range] {0 <= n <= FFh}

[Outline] Selecting the LF switch valid/invalid.

- "n" is valid only in the lowest bit (n0).
- "n" bit means the followings.
 - 0** LFSW valid.
 - 1** LFSW invalid.

[Caution] When the panel switch is disabled with this command, the LF switch is disabled. Therefore, the paper cannot be fed by operating the LF switch.

[Default] • The initial value of **n** is "0".

[Sample Program]

```
LPRINT CHR$ (&H1B) + "c5" + CHR$ (0); &#188;&#188;
When enabling the LF switch
LPRINT CHR$ (&H1B) + "c5" + CHR$ (1); &#188;&#188;
When disabling the LF switch
```

36. ESC d n

Printing and Feeding the paper by **n** lines

[Code] **[1Bh] + [64h] + n**

[Range] {0 <= n <= FFh}

[Outline] Prints data inside the buffer and feeds paper by **n** lines.

- Specified line does not remain.
- The beginning of the line is to be considered as the next printing start position.

[Default] • The initial value is not defined.

[Sample Program]

```
LPRINT "AAAAA"
LPRINT CHR$ (&H1B) + "d" + CHR$ (2);
LPRINT "AAAAA" + CHR$ (&HA);
```

[Print Results]

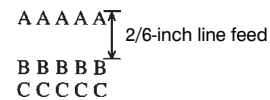

37. ESC i

Cutting the paper

[Code] **[1Bh] + [69h]**
 [Outline] Performs a paper feed, so the last printed line remains after the cover's cutting edge.
 This command is valid only at the beginning of the line.

38. ESC m

Cutting the paper

[Code] **[1Bh] + [6Dh]**
 [Outline] The command is exactly the same as ESC i.

39. ESC p

Generating a drawer-kick pulse

[Code] **[1Bh] + [70h] + m + n1 + n2**
 [Range] { 0 <= m <= 255 }
 { 0 <= n1 <= 255 }
 { 0 <= n2 <= 255 }
 [Outline] The value of **m** is ignored.
 The printer generates a 2*n1 milliseconds long pulse and 2*n2 milliseconds long rest after the pulse. n2 must be at least four times greater than n1 or the command will be discarded.

[Sample Program]
 LPRINT CHR\$(&H1B) + "p";
 LPRINT CHR\$(0);
 LPRINT CHR\$(5); Sets ON time to 10ms
 LPRINT CHR\$(50); Sets OFF time to 100ms
 END

40. ESC t

Selecting the character code table

[Code] **[1Bh] + [74h] + n**
 [Range] { 0 <= n <= 19 }
 [Outline] Selects the code table for ASCII codes 80h-FFh.
 In the international version of the printer one of the following supported code tables is selected according to the value of **n**:

n	Code Table
0	USA (CP437)
1	Litva
2	West Europe Latin I (CP850)
3	Brasil (CP860)
4	Poland
5	Bulgarian (CP856)
6	Central Europe Latin II (CP852)
7	Russian (CP866)
8	Turkish (CP857)
9	Windows English Latin I (CP1252)
10	Baltic (CP775)
11	Latvia
12	Greek (CP737)
13	Hebrew (CP862)
14	Windows Central European Latin II (CP1250)
15	Windows Cyrilic (CP1251)
16	Windows Greek (CP1253)
17	Windows Turkish (CP1254)
18	Windows Hebrew (CP1255)
19	Windows Baltic (CP1257)

In the Chinese version of the printer one of the following supported code tables is selected according to the value of **n**:

n	Code Table
0	USA (CP437)
1	Chinese GB2312

[Caution] In the international version of the printer when the code page is set by the DIP switches the command is disabled and a code page other than this one cannot be set.
 In the Chinese version of the printer the code table can be changed regardless of the DIP switch setting.
 If the code page is set by the DIP switches the command ESC > will store this code page into the flash for further use.

[Default] The default value is 0 – USA CP437 code page.

41. ESC v

Transmitting the printer status

[Code] **[1Bh] + [76h]**

[Outline] Current printer status is transmitted.
 Status sent out consists of 1 byte whose content is as in the table below.

Bit	Function	Value 0	Value 1
0		Not defined	
1		Not defined	
2	Paper end	With paper	Without paper
3	Head temperature	Normal	Overheated
4		Not defined	
5		Not defined	
6		Not defined	
7		Not defined	

[Sample Program]

```
OPEN "COM1:N81NN" AS #1;
PRINT #1, CHR$ (&H1B); "v";
A$ = INPUT$ (1, #1);
CLOSE #1
END
```

42. ESC x n

Reversing the print direction

[Code] **[1Bh] + [78h] + n**

[Outline] This command changes the characters' print direction from left to right to right to left. The character itself is not mirrored horizontally. The command is intended for languages that use right to left scripting, like Hebrew and Arabic.
 Only the lowest bit of "n" is valid with the following meaning:
 0 – left to right printing
 1 – right to left printing

[Caution] The command changes only the print direction of the characters - all graphics and bar codes are unaffected.
 This command is ignored in the Chinese version of the printer.
 The command reverses all print attributes of the line and the characters, though the characters themselves are not mirrored horizontally.
 Though the command allows mixing reversed and non-reversed characters in one line the print results could be unsatisfactory and unreliable.

[Default] The default value is 0 – left to right printing.

[Example] 

43. ESC { n

Specifying/Canceling the Inverted Characters

[Code] **[1Bh] + [7Bh] + n**

[Range] {0 <= n <= FFh}

[Outline] Specifying/canceling inverted characters.
 • "n" is valid only for the lowest bit (n0).
 • Bit n (n0) means the followings.
 0 Canceling inverted characters.
 1 Specifying inverted characters.

[Caution] • Inverted printing means printing the line at 180° turned.
 • Valid is the last value specified in a line.

[Default] • The initial value of n is "0".

[Sample Program]

```
LPRINT CHR$ (&H1B) + "{" + CHR$ (0);
LPRINT "AAAAA" + CHR$ (&HA);
LPRINT "BBBBB" + CHR$ (&HA);
LPRINT CHR$ (&H1B) + "{" + CHR$ (1);
LPRINT "AAAAA" + CHR$ (&HA);
LPRINT "BBBBB" + CHR$ (&HA);
```

[Print Results]

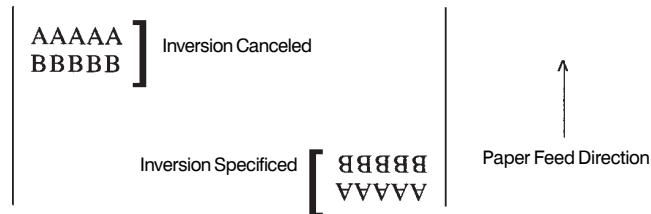

44. GS (A pL pH n m

Printing a self-test

[Code] **[1Dh] + [28h] + [41h] + pL + pH + n + m**

[Range] { 0 <= pL <= 255 }
 { 0 <= pH <= 255 }
 { 0 <= n <= 255 }
 { 2 <= m <= 3 }

[Outline] This command is intended for compatibility purposes. A "short" or "long" test is printed depending on the value of m.
 m = 2 – printing a "long" test (ESC .)
 m = 3 – printing diagnostic information ("short" test) (ESC ,)

45. GS B n

Specifying/canceling the black/white inverted printing

[Code] **[1Dh] + [62h] + n**

[Range] { 0 <= n <= 255 }

[Outline] According to the least significant bit of n (n0) the following modes are possible:

- n0 = 0 – Black/white inverted printing is canceled
- n0 = 1 – Black/white inverted printing is specified

The space skipped by tab command or by positioning commands (ESC \$, ESC \) is not affected.

Both built-in and downloaded character sets are inverted by this command.

The black/white inversion works on the right space defined by ESC SP command.

[Default] The initial value is n=0

[Sample Program]

```
LPRINT CHR$(&H1D) + "B" + CHR$(0);
LPRINT "AAAAA";
LPRINT CHR$(&H1D) + "B" + CHR$(1);
LPRINT "AAAAA";
```

[Print Results]

```
AAAAA AAAAA
```

46. GS C

Getting current date and time

[Code] **[1Dh] + [43h]**

[Outline] • Gets the current date and time. The result string consists of six decimal numbers in ASCII format each consisting of two digits. The numbers are divided by space, the string ends with a NULL character.

• The parameters are in order: year, month, day, day of the week, hour, minute, seconds.

• If the real time clock is not set only NULL character is returned.

47. GS L n1 n2

Setting the left margin

[Code] **[1Dh] + [4Ch] + n1 + n2**

[Range] {0 <= n1 <= FFh}
{0 <= n2 <= FFh}
{n1+256*n2 < 384}

[Outline] Sets the position in dots (1/203 inches) from which each line starts. This command works only if entered at the beginning of the line. The start position is equal to **n1+256*n2** dots from the left end of the printable area.

[Caution] If a value that exceeds the length of the print area is set the left margin is set to 0.

[Default] Default value is 0.

48. (1) GS V m

(2) GS V m n

Cutting the paper

[Code] **(1) [1Dh] + [56h] + m**
(2) [1Dh] + [56h] + m + n

[Range] (1) {m=1, m=49}
(2) {m=66}
{0 <= n <= 255}

[Outline] Depending on the value of **m** one of the following actions is performed:

- If m=1 or m=49 ('1') a paper feed, so the last printed line remains after the cover's cutting edge is performed.
- If m=66 ('B') the paper is fed by n/8 mm.
In both cases the paper is first fed to the cut position so the last printed line remains after the cutter's edge. This means at in case (2) the paper is fed by "cut position + n/8" millimeters total.

49. GS c parameter string

Setting the real time clock

[Code] **[1Dh] + [63h] + ASCII string**

[Outline] • Sets the real time clock. The parameter string consists of six decimal numbers in ASCII format each consisting of two digits. The numbers are divided by space, the string ends with a NULL character.

• The parameters are in order: year, month, day, day of the week, hour, minute.

[Default] • The initial value is not specified.

50. (1) GS k m [d] k NUL

(2) GS k m n [d] k

(3) GS k m a [d] k NUL

(4) GS k m a xL xH [d] k

Printing the barcode

[Code] **(1) [1Dh] + [6Bh] + m + D_i + [00h]**
(2) [1Dh] + [6Bh] + m + n + D_i
(3) [1Dh] + [6Bh] + m + a + D_i + [00h]
(4) [1Dh] + [6Bh] + m + a + xL + xH + D_i

[Range] (1) {0 <= m <= 6}
(2) {65 <= m <= 73}
(3) {m=9; a=0,1}
(4) {m=74; 256*xH+xL <= 3000; a=0,1}

[Outline] Specifying a type of barcode and printing barcodes.

- The beginning of line is considered as the next printing start position.
- Depending on the value of **m**, the following barcode can be selected.
d indicates a barcode data to be printed and **k** indicates the number of character to be printed.
n indicates number of characters when 65 <= m <= 73.

a is a setting for PDF-417 barcode. Setting **a=0** will make the printer to automatically choose PDF-417 compression modes, while **a=1** will force byte compression mode.

xL and **xH** indicates the number of bytes for PDF-417 barcode when **m=74**. The number of bytes is equal to **256*xH+xL**.

m determines barcode type and it is one of the following:

m(1)	Barcode type	Length	Range of 'd'
0	UPC-A	11	48 ≤ D _i ≤ 57
1	UPC-E	11	48 ≤ D _i ≤ 57
2	EAN13 (JAN13)	12	48 ≤ D _i ≤ 57
3	EAN 8 (JAN8)	7	48 ≤ D _i ≤ 57
4	CODE 39	-	48 ≤ D _i ≤ 57, 65 ≤ D _i ≤ 90, 32, 36, 37, 43, 45, 46, 47
5	ITF	-	48 ≤ D _i ≤ 57
6	CODABAR (NW-7)	-	48 ≤ D _i ≤ 57, 65 ≤ D _i ≤ 68, 36, 43, 45, 46, 47, 58
7	CODE 93	-	1 ≤ D _i ≤ 127
8	CODE 128	-	1 ≤ D _i ≤ 127
9	PDF-417	-	1 ≤ D _i ≤ 255

M(2)	Barcode type	Length	Range of 'd'
65	UPC-A	11	48 ≤ D _i ≤ 57
66	UPC-E	11	48 ≤ D _i ≤ 57
67	EAN13 (JAN13)	12	48 ≤ D _i ≤ 57
68	EAN 8 (JAN8)	7	48 ≤ D _i ≤ 57
69	CODE 39	-	48 ≤ D _i ≤ 57, 65 ≤ D _i ≤ 90, 32, 36, 37, 43, 45, 46, 47
70	ITF	-	48 ≤ D _i ≤ 57
71	CODABAR (NW-7)	-	48 ≤ D _i ≤ 57, 65 ≤ D _i ≤ 68, 36, 43, 45, 46, 47, 58
72	CODE 93	-	0 ≤ D _i ≤ 127
73	CODE 128	-	0 ≤ D _i ≤ 127
74	PDF-417	-	0 ≤ D _i ≤ 255

[Caution]

- When data being held in the print buffer, this command is ignored.
- Regardless of the specified feed pitch, this command feeds the paper that is required to print a barcode.
- If the character code d cannot be printed in the respective barcode system, the barcode so far will be printed, processing the subsequent data as normal data.

- When a barcode whose number of characters to be printed is fixed has been selected, the number of characters **k** have to be always made equal to the number of characters to be printed. (The barcode is not printed when not matching.)
- When the horizontal direction exceeds one line length, the barcode is not printed.

[CODE 128 additional information]

Code 128 covers all ASCII codes from 0 to 127, and it has three tables A, B and C that can be used in the same bar code.

Table A: contains ASCII symbols with codes 0 to 95 and control symbols FNC1, FNC2, FNC3, FNC4, SHIFT, CODEB, CODEC.

Table B: contains symbols with ASCII codes from 32 to 127 and control characters FNC1, FNC2, FNC3, FNC4, SHIFT, CODEA, CODEC.

Table C: It is used for coding bar code areas that consist only of numerals. Each symbol gives two digits that are coded with ASCII codes from 0 to 99. Control characters FNC1, CODEA, CODEB are also available.

The bar code must start with one of the symbols CODEA, CODEB or CODEC, that determines which table will be used. If it is necessary the current table could be changed later by inserting one of these symbols in to the bar code. The symbol following SHIFT character is considered to be from table B, if table A is current, or from table A, if table B is current. If a symbol that is not valid for the current table is used, the whole bar code is not printed.

Control symbols are assigned two bytes as follows:

Symbol	Code system		
	Decimal	Hexadecimal	Text
FNC1	123, 49	7B, 31	{1
FNC2	123, 50	7B, 32	{2
FNC3	123, 51	7B, 33	{3
FNC4	123, 52	7B, 34	{4
CODEA	123, 65	7B, 41	{A
CODEB	123, 66	7B, 42	{B
CODEC	123, 67	7B, 43	{C
SHIFT	123, 83	7B, 53	{S
{	123, 123	7B, 7B	{{

51. GS w n

Selecting the horizontal size (Scale factor) of the bar code

- [Code] **[1Dh] + [77h] + n**
- [Range] {2 <= n <= 4}
- [Outline] Selecting bar code width.
n denotes the number of dots in fine element width.
- [Default] • The initial value of this width is "3".

```
[Sample Program]
LPRINT CHR$ (&H1D) + "h" + CHR$ (30);
LPRINT CHR$ (&H1D) + "w" + CHR$ (2);
GOSUB BC
LPRINT CHR$ (&H1D) + "h" + CHR$ (50);
LPRINT CHR$ (&H1D) + "w" + CHR$ (3);
GOSUB BC
END
BC:
LPRINT CHR$ (&H1D) + "k";
LPRINT CHR$ (4);
LPRINT "12" + CHR$ (0);
RETURN
```

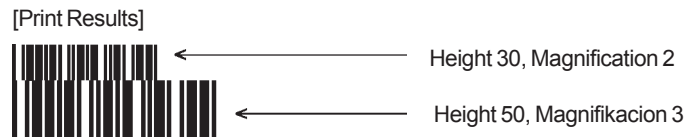

52. GS h n

Selecting the height of the Barcode

- [Code] **[1Dh] + [68h] + n**
- [Range] {1 <= n <= FFh}
- [Outline] Selecting barcode height.
n denotes the number of dots in the vertical direction.
- [Default] • The initial value of n is "162".

53. GS H n

Selecting of Printing Position of HRI Code

- [Code] **[1Dh] + [48h] + n**
- [Range] {0 <= n <= 3}
- [Outline] Selecting printing position of HRI code in printing barcodes.
 - "n" means the followings.
 - 0 No printing
 - 1 Above the barcode
 - 2 Below the barcode
 - 3 Both above and below the barcode

The HRI code refers to the barcode-turned characters so that you can read them.

[Caution] The HRI code is printed in the font selected with GS f. Specify before the GS k command.

[Default] • The initial value of n is "0".

[See Also] GS f

```
[Sample Program]
LPRINT CHR$ (&H1B) + "3" + CHR$ (5);
LPRINT CHR$ (&H1D) + "h" + CHR$ (50);
LPRINT CHR$ (&H1D) + "H" + CHR$ (0);
GOSUB BC
LPRINT CHR$ (&H1D) + "H" + CHR$ (1);
GOSUB BC
LPRINT CHR$ (&H1D) + "H" + CHR$ (2);
GOSUB BC
LPRINT CHR$ (&H1D) + "H" + CHR$ (3);
GOSUB BC
END
BC:
LPRINT CHR$ (&H1D) + "k";
LPRINT CHR$ (4);
LPRINT "12" + CHR$ (0);
LPRINT CHR$ (&HA);
RETURN
```

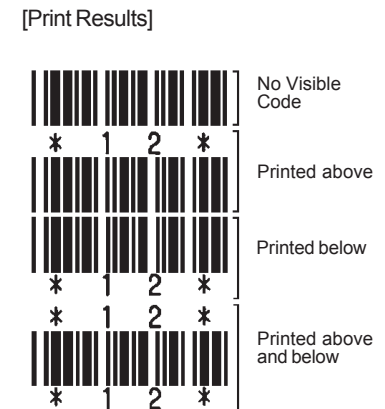

54. GS f n

Selecting the font of HRI code

[Code] **[1Dh] + [66h] + n**

[Range] n = 0, 1

[Outline] Selecting the font of HRI code in printing barcode.
The type of font can be printed by selecting n is as follows.

0 Font A

1 Font B

The HRI code refers to the barcode-turned characters so that you can read them.

[Caution] The HRI code is printed at the position specified with GS h.

[Default] The initial value of n is "0".

[See Also] GSH

[Sample Program]

```
LPRINT CHR$ (&H1D) + "h" + CHR$ (50);
LPRINT CHR$ (&H1D) + "H" + CHR$ (2);
LPRINT CHR$ (&H1D) + "f" + CHR$ (0);
GOSUB BC
LPRINT CHR$ (&H1D) + "f" + CHR$ (1);
GOSUB BC
END
BC:
LPRINT CHR$ (&H1D) + "k";
LPRINT CHR$ (4);
LPRINT "123" + CHR$ (0);
LPRINT CHR$ (&HA);
RETURN
```

[Print Results]



55. GS p n1 n2 n3

Setting barcode PDF-417 parameters

[Code] **[1Dh] + [70h] + n1 + n2 + n3**

[Range] {0 <= n1 <= 255}
{0 <= n2 <= 30}
{n3=0; 3 <= n3 <= 90}

[Outline] **n1** selects PDF-417 security level. Setting a security level higher than eight forces the printer to automatically adjust the security level according to the following table:

EC level	EC Codewords	Auto Select Level
0	2	-
1	4	0-31
2	8	32-63
3	16	64-127
4	32	128-255
5	64	256-511
6	128	512-928
7	256	-
8	512	-

- Only real data codewords in the security level calculation (any pad codewords are ignored).
- n2** – number of data columns. If **n2=0** the number of data columns is automatically calculated.
- n3** – number of rows. If **n3=0** the number of rows is automatically calculated.

[Caution] If any value is out of range this value remains unchanged. Thus the other values are changed.

[Default] The initial value of n1 is "9" (auto select).
The initial value of n2 is "0" (auto select).
The initial value of n3 is "0" (auto select).

[See Also] GS k

[Sample Program]

```
LPRINT CHR$( &H1D) + "p";
LPRINT CHR$(4) + CHR$(2) + CHR$(0);
LPRINT CHR$( &H1D) + "k";
LPRINT CHR$(9) + CHR$(0);
LPRINT "ABCDEF 0123456789 abcdef";
LPRINT CHR$(0);
```

[Print Results]



56. GS v0

Printing of raster bit image

[Code] **[1Dh] + [76h] + [30h] + m + xL + xH + yL + yH + D₁ + ... + D_n**

[Range] {0 <= m <= 3; 48 <= m <= 51}
 {0 <= xL <= 255}
 {0 <= xH <= 255}
 {0 <= yL <= 255}
 {0 <= yH <= 255}
 {0 <= D_i <= 255}

[Outline] The value of xH is ignored.
 Although yH could be from 0 to 255 the high four bits are ignored, so yH could actually be from 0 to 15.
 xL is the number of bytes in horizontal direction (xL*8 dots).
 The number of dots in horizontal direction is equal to yL+yH*256.
 The number of data bytes k=xL * (yL+yH*256). However k must not be equal to 0 or the bit image will be discarded.
 m defines the printing mode of the bit image according to the following table:

m	Mode	Dot density in vertical direction	Dot density in horizontal direction
0	Normal	203 DPI	203 DPI
1	Double width	203 DPI	101 DPI
2	Double height	101 DPI	203 DPI
3	Quadruple	101 DPI	101 DPI

The bit image is defined line by line from left to right. The most significant bit of each byte is the leftmost dot and the least significant bit is rightmost dot.

The data that exceeds the printing width of the line is discarded.

The raster bit image could be positioned using the commands ESC \, ESC \$ and GS L.

The raster bit image could be justified using the ESC a command. If this command is executed during a macro definition, the macro definition is finished and the command is executed.

57. GS *

Defining the Download Bit Image

There are two variants of this command depending of the position of switch 5.

If switch 5 is OFF:

[Code] **[1Dh] + [2Ah] + n1 + n2 + D₁ + ... + D_n**

[Range] {0 <= n1 <= 255}
 {0 <= n2 <= 68}
 {0 <= D_i <= 255}

[Outline] n1 denotes the horizontal size of the bit image
 n2 denotes the vertical size of the bit image
 There are **n1*n2*8** bytes of data in order from top to bottom and from left to right, n1 bytes in each vertical column of dots.
 This command defines a bit image with number of dots determined by n1 and n2. There are n1*8 dots in horizontal direction and n2*8 number of dots in vertical direction.
 If n1 is 0 the downloaded bit image is cleared.
 The command GS / is used to print downloaded bit image.

If switch 5 is ON:

[Code] **[1Dh] + [2Ah] + n1 + n2 { + n21 + n22 } + D₁ + ... + D_N**
 [Range] {0 <= n1 <= 7Fh}
 {0 <= n2 <= F8h}
 {0 <= D₁ <= FFh}
 {1 <= n21+256*n22 <= 544}

[Outline] If n2 is 0 two more bytes are read. These two bytes then determine the vertical size of the bit image. The vertical size then is N= n21+256*n22 rows.
 If N is the vertical size of the bit image, N=n2 or N= n21+256*n22.
 D_i is the bit image's data. The number of data bytes is n1*N.
 There are n1 bytes in the first row then n1 bytes in the second, etc. There are N rows in the bit image, and the number of dots in the bit image is n1*N*8. Each data bit defines one dot, value of "1" corresponds to black.
 If n1 is 0 the downloaded bit image is cleared.
 The downloaded bit image remains effective even if the printer is switched off.

[See Also] GS /

[Sample Program]

```
GOSUB IMG
LPRINT CHR$ (&H1D) + "/" + CHR$ (0);
LPRINT CHR$ (&H1D) + "/" + CHR$ (1);
LPRINT CHR$ (&H1D) + "/" + CHR$ (2);
LPRINT CHR$ (&H1D) + "/" + CHR$ (3);
END
IMG:
n 1 = 10 : n 2 = 5
LPRINT CHR$ (&H1D) + "****";
LPRINT CHR$ (n1) + CHR$ (n2);
FOR J=1 TO n1*8
FOR I=1 TO n2
LPRINT CHR$ (J);
NEXT I
NEXT J
RETURN
```

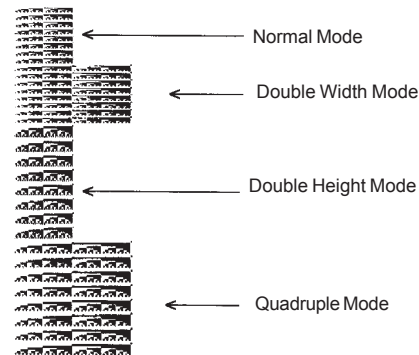

[Print Results]

58. GS / m

Printing the downloaded bit image

[Code] **[1Dh] + [2Fh] + m**
 [Range] {0 <= m <= 3}

[Outline] Prints download bit image in a mode specified by m.

m	Mode Name	Dots in Vertical Direction	Dots in Horizontal Direction
0	Normal mode	203 DPI	203 DPI
1	Double wide mode	203 DPI	101 DPI
2	Double high mode	101 DPI	203 DPI
3	DW/DH mode	101 DPI	101 DPI

[Caution] • When data exist inside the print buffer, this command is ignored.
 • When a download bit image has not been defined, this command is ignored.
 • A portion of a download bit image exceeding one line length is not printed.

[Default] • The initial value is not specified.

[See Also] GS *

59. GS :

Starting / Ending Macro Definition

[Code] **[1Dh] + [3Ah]**

[Outline] Specifying starting / ending macro definition. Means termination when received while defining a macro.

[Caution] Maximum content available for macro definition is 3823 bytes. A portion exceeding 3823 bytes is not defined.

- Even with ESC @ (initialization of the printer) having been executed, defined content is not cleared. Therefore, it is possible to include ESC @ into the content of macro definition.
- Normal printing operation is carried out even while in macro definition

[Default] • Initially, Macro is not specified.

[See Also] GS ^

[Sample Program]

```
LPRINT CHR$ (&H1D) + ":";
LPRINT "+ " + CHR$ (&HA);
LPRINT " | | " + CHR$ (&HA);
LPRINT "+ " + CHR$ (&HA);
LPRINT CHR$ (&H1D) + ":";
LPRINT CHR$ (&H1D) + "^";
LPRINT CHR$ (2) + CHR$ (10);
LPRINT CHR$ (0);
```

[Print Results]

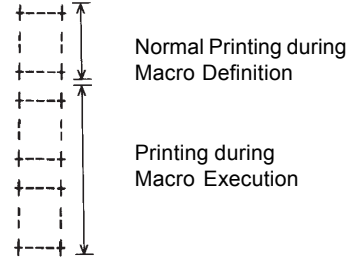

60. GS ^ n1 n2 n3

Executing the Macro

[Code] **[1Dh] + [5Eh] + n1 + n2 + n3**

[Range] {0 <= n1 <= FFh}
 {0 <= n2 <= FFh}
 {0 <= 3 <= 1}.

[Outline] Executing contents defined in macro.

• “n1~n3” indicate as follows:

- n1 : The number of times of macro execution
- n2 : Waiting time on macro execution

Waiting time of n2 x 100 msec is given for every execution.

- n3 : Macro execution mode
 - 0 Continuous execution
 - 1 Execution by LFSW

Continuous execution: The Macro is executed n1 times continuously at the time intervals specified by n2.

Execution by FEED S: After waiting for lapse of time specified by n2, the LF switch is waited to be pressed. When it is pressed, the macro is executed once. This action is repeated n1 times.

- [Caution]
- When this command is received while in macro definition, suspension of macro definition is indicated. At this time, the defined content is cleared.
 - No execution takes place when macro is held undefined or n1=0.
 - While in macro execution with n3=1, paper feed with the LF SW is not available.

[Default] • Initially, this command is not specified.

[See Also] GS :

61. FS p n m

Printing the downloaded NV bit image

[Code] **[1Ch] + [70h] + n + m**

[Range] {0 <= n <= FFh}
 {0 <= m <= 3}
 {48 <= m <= 51}

[Outline] Printing the downloaded NV bit image defined by FS q command.

m	Mode Name	Dots in Vertical Direction	Dots in Horizontal Direction
0, 48	Normal mode	203DPI	203DPI
1, 49	Double wide mode	203DPI	101DPI
2, 50	Double high mode	101DPI	203DPI
3, 51	DW/DH mode	101DPI	101DPI

“n” is discarded - the printer supports only one NV bit image.
 “m” is the bit image printing mode.

62. FS q n [xL xH yL yH D1 D2 ... Dk]

Defining the downloaded NV bit image

There are two variants of this command depending of the position of switch 5.

If switch 5 is OFF:

[Code] **[1Ch] + [71h] + n + xL + xH + yL + yH + D1 + D2 + ... + Dk**

[Range] {0 <= n <= FFh}
 {0 <= xL <= FFh}
 {0 <= xH <= FFh}
 {0 <= yL <= FFh}
 {0 <= yH <= FFh}
 {0 <= D <= FFh}

[Outline] This command defines the specified NV (non volatile) bit image. The bit image is stored into the flash.

n is ignored – the printer supports only one bit image.

xL and xH denote the horizontal size of the NV bit image as (xL + xH x 256) x 8 dots.

yL and **yH** denote the vertical size of the **NV** bit image as
 $(yL + yH \times 256) \times 8$ dots.

Total amount of data defining the bit image is
 $(xL + xH \times 256) \times (yL + yH \times 256) \times 8$ bytes.

- [Details] The maximum printable size of the NV bit image is 384×512 dots. This corresponds to $(xL + xH \times 256) < 48$ and $(yL + yH \times 256) < 64$.
 The exceeding data is read but discarded.
 The order of the data is from top to bottom and then from left to right, $(yL + yH \times 256)$ bytes in each vertical column of dots.
 The printer will become busy before each writing cycle in the NV memory. Any data sent while the printer is busy may not be processed and therefore could be lost.
 $xL = xH = yL = yH = 0$ clears the downloaded bit image.

If **switch 5** is **ON**:

[Code] **[1Ch] + [71h] + n + xL + xH + yL + yH + D1 + D2 + ... + Dk**

[Range] {0 <= n <= FFh}
 {0 <= xL <= FFh}
 {0 <= xH <= FFh}
 {0 <= yL <= FFh}
 {0 <= yH <= FFh}
 {0 <= D <= FFh}

- [Outline] This command defines the specified NV (non volatile) bit image. The bit image is stored into the flash.
n is ignored – the printer supports only one bit image.
xL and **xH** denote the horizontal size of the **NV** bit image as
 $(xL + xH \times 256) \times 8$ dots.
yL and **yH** denote the vertical size of the **NV** bit image as
 $(yL + yH \times 256)$ dots.
 Total amount of data defining the bit image is
 $(xL + xH \times 256) \times (yL + yH \times 256)$ bytes.

- [Details] The maximum printable size of the NV bit image is 384×512 dots. This corresponds to $(xL + xH \times 256) < 48$ and $(yL + yH \times 256) < 512$.
 The exceeding data is read but discarded.
 The order of the data is from left to right and then from top to bottom, $(xL + xH \times 256)$ bytes in each horizontal row of dots.
 The printer will become busy before each writing cycle in the **NV** memory. Any data sent while the printer is busy may not be processed and therefore could be lost.
 $xL = xH = yL = yH = 0$ clears the downloaded bit image.