

**USCutter** 

# *ZenCut Black*

## **User Manual**



## **NOTICE**

USCutter reserves the right to modify the information contained in this user manual at any time without prior notice; un-authorized modification, copying distribution or display is prohibited. All comments, queries or suggestions concerning this manual please consult our service department.

## **USCUTTER SERVICE POLICIES**

- 24/7 Online Support: If you should experience a problem with your machine, please go to [www.uscutter.com](http://www.uscutter.com) and click “**Support.**” Click on '**Submit A Ticket**'. You will then be prompted to enter your information and describe the situation. Please be specific in your explanation of the problem.
- Our Technical Support Staff will review your ticket and contact you regarding troubleshooting procedures. PLEASE BE PATIENT! Our technicians respond to tickets in the order that they are received.
- Technical Support will assist you in troubleshooting and repairing your machine via phone or internet.
- If we determine that repair cannot be accomplished via these methods, an RMA (Return Merchant Authorization) will be issued. **Returns without an RMA with not be accepted.** **Repair costs may apply for non-warranty issues.** If a replacement part is needed, a deposit MUST be paid for the replacement at the time the part order is placed. It will be refunded upon our receipt of the defective part. You are responsible for shipping costs to and from our facility.

### ADDRESS FOR RETURNS:

USCutter RMA #-----  
19510 144th Ave NE, Ste. C1  
Woodinville, WA, 98072

### TO REACH SERVICE BY PHONE:

425-481-3555 x Option 2  
Hours: 8:00am-5:00pm Mon-Fri (Pacific)

## **ZENCUT WARRANTY**

This product comes with TWO YEAR(Green) (THREE YEAR Black) warranty from date of retail purchase for US buyers only. Warranty repairs will require buyer to pay for shipping both ways. Warranty does not cover consumable parts and does not cover misuse or abuse of equipment. This includes damage caused by improper shipment packaging on the part of the customer.

## **15 - DAY RETURN POLICY**

We do not offer full refunds on returned items. If you want to return your unit within 15 days of purchase, you may return it to us as long as we receive the unit back as it was originally boxed, with all accessories, and no damage. We have had some returns where customers are careless about packaging the return shipment, and we must stress, if you do not package the unit well, damage costs will be deducted from your refund. The customer is required to pay the return shipping. You will be refunded the purchase price minus original shipping charges and be charged a 20% restocking fee.

## Important Information

Thanks for your purchase of ZenCut Black Cutting Plotter. For your safety and to optimize the performance of the ZenCut Black, please read the user manual completely and keep it in a convenient location.

### PRECAUTIONS IN USE

- For safety reasons, please always lift the cutter firmly **from the bottom** when moving it. Do not move the cutter by clasping the depression area on either side.

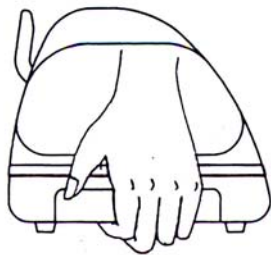

(O)

hold from the bottom

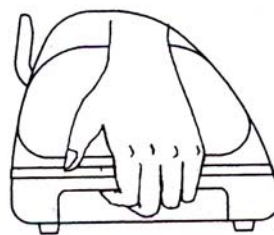

(X)

hold the depression area

- Do not shake or drop the blade holder, as the blade may become loose.
- During operation, keep away from any moving parts of the cutter (such as the carriage, drums). Also be careful of loose clothing and other foreign objects.
- Always connect the power cable to a grounded outlet.
- Always use the accessory power cable that is provided. Do not bend or pinch the power cable.
- Do not plug power cable into an outlet with other appliances, or use an extension cable. There is danger of overheating and/or machine malfunction.
- Keep the tools out of the reach of children.
- Always put the pinch rollers within position of the white marks.

**Warning**

Never press the top release grip and pull the bottom release grip at the same time. Correct operation is shown below:

**O (CORRECT)**

**X (INCORRECT)**

**Press**

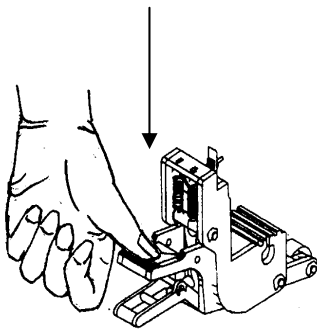

**DISABLE**



**Press down**

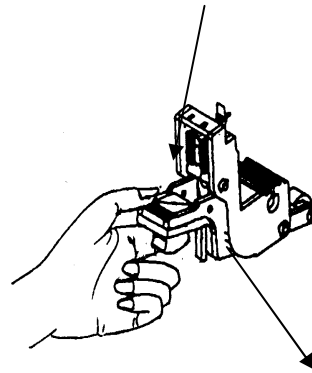

**Stop bar**

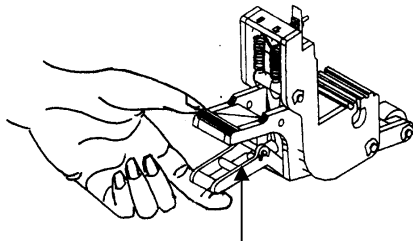

**Pull up bottom to release *grip***

**ENABLE**



**NOTE**

If the grips have clipped together due to incorrect operation, you can use tweezers to pull out the stop bar while pressing down the top release grip. Keep the stop bar pulled out, then release the grips as shown in the bottom-left figure.

# Table of Contents

## Important Information

### 1. General Information

1.1	Introduction	1-1
1.2	Package Items	1-1
1.3	Product Features	1-2
1.4	Appearance of ZenCut Black	
1.4.1	The Front View	1-3
1.4.2	The Back View	1-3
1.4.3	The Whole View	1-4
1.4.4	The Left-hand Side	1-4
1.4.5	The Right-hand Side	1-5

### 2. Installation

2.1	Precaution	2-1
2.2	Stand & Flexible Media Support System	2-2
2.3	Desktop Flexible Media Support System	2-6
2.4	Blade Installation	2-8
2.5	Cable Connections	
2.5.1	USB Interface	2-10
2.5.2	Parallel Interface	2-10
2.5.3	RS-232 Interface	2-11
2.5.4	Data Transmitting	2-11

### 3. The Control Panel

3.1	The LCD Panel	3-1
3.2	Menu in On-line Mode	3-2
3.3	Menu in Off-line Mode	3-3
3.4	Menu Items	3-4

### 4. Operation

4.1	Media Loading	
4.1.1	Loading the Sheet Media	4-1
4.1.2	Loading the Roll Media	4-3
4.2	Tracking Performance	4-5
4.3	Cutting Force and Offset Adjustment	4-6
4.4	How to Cut 3mm Letter	4-7
4.5	How to Make A Long Plot	4-7
4.6	When Completing the Cutting Job	4-8

### 5. Accu-Aligning System

5.1	Introduction	5-1
5.2	Calibrating the System	
5.2.1	Media Calibration	5-2
5.2.2	AAS Calibration	5-2
5.2.3	AAS II on ZenCut Black	5-3
5.3	Printer Test	5-4
5.4	Contour Cutting	5-6

---

5.5	Tips for AAS	5-8
<b>6. Maintenance</b>		
6.1	Cleaning the Cutting Plotter	6-1
6.2	Cleaning the Grid Drum	6-2
6.3	Cleaning the Pinch Rollers	6-2
<b>7. Trouble Shooting</b>		
7.1	Non-Operational Problems	7-1
7.2	Operational Problems	7-2
7.3	Communication Problems	7-3
7.4	Software Problems	7-4
7.5	Cutting Quality Problem	7-5
7.6	USB connection Problems	7-6
<b>Appendix</b>		
A-1	ZenCut Black Specification	A-1
A-2	Blade Specification	A-2
A-3	CoreIDRAW Plug-In Instruction	A-3

# Chapter 1 General Information

## 1.1 Introduction

ZenCut Black series cutting plotters have been designed to produce computer-generated images or perform contour cutting on sheets or rolls of vinyl media.

This manual covers the following models of ZenCut Black series cutting plotters:

• ZCB-61	for media width: 2"(50mm) ~ 30"(770mm)
• ZCB-101S	for media width: 2"(50mm) ~ 50"(1270mm)
• ZCB-132S	for media width: 2"(50mm) ~ 62.7"(594mm)
• ZCB-183S	for media width: 12"300mm) ~ 74.8"(1900mm)

## 1.2 Package Items

The ZenCut Black package contains the following items. Please check carefully before assembling. If you find any item(s) missing, please consult your dealer for further assistance.

Standard Item	Quantity
<b>1. Cutting Plotter</b>	<b>1</b>
<b>2. Stand Set ( for ZCB-101S/132S/183S only )(Optional for ZCB-61)</b>	<b>1</b>
● 1 H-shape stand	
● 2 stands	
● 1 stand beam	
● 4 Hold Plugs	
● 24 M6 screws	
● 1 M5 L-shape hexagon screw driver	
● 4 Stand Wheels	
● 1 Installation Guide for Stand Set	

<b>3. Flexible Media Support System Package</b>			<b>1</b>
Items	183S/132S/101S	61	
1 set of Roll Media Flange (2 pieces)	V	V	
1 set of Roll Holder (2 pieces)	V	V	
1 set of Roll Holder Guide Bushes (4 pieces)	V	V	
1 set of Roll Holder Support (2 pieces)	V	V	
1 M6 L-shape hexagon screw driver	V	V	
1 Installation Guide for Roll Holder		V	
1 M5 L-shape hexagon screw driver		V	
1 set of Desktop Support Brackets (2 pieces)		V	
4 Plastic Foot		V	
4 M4 screws		V	
12 M6 screws		V	
1 M4 L-shape hexagon screw driver		V	
<b>4. Accessory Bag</b> <ul style="list-style-type: none"> <li>● 1 User CD</li> <li>● 1 AC power Cord</li> <li>● 1 data cable (RS-232C)</li> <li>● 1 data cable (Print cable)</li> <li>● 1 data cable (USB cable)</li> <li>● 1 Blade Holder Assembly (Installed in tool carriage of the cutting plotter)</li> <li>● 1 Blade (Installed in Blade Holder)</li> <li>● 1 Safe Blade</li> <li>● 1 Cutting Pad for Vinyl Cutting</li> <li>● 1 Tweezers</li> </ul>			<b>1</b>

### 1.3 Product Features

The following are the main features of the ZenCut Black series cutting plotters:

- Tri-port connectivity provides you with greater flexibility.
- Up to 600-gram cutting force.
- Up to 60-inch/per second cutting speed.
- Guaranty 10-meter tracking.
- User friendly, multi-language control panel
- Convenient media basket.
- Enhanced Accu-Aligning System for contour cutting.



## 1.4 Appearance of ZenCut Black

### 1.4.1 The Front View (Figure 1-1)

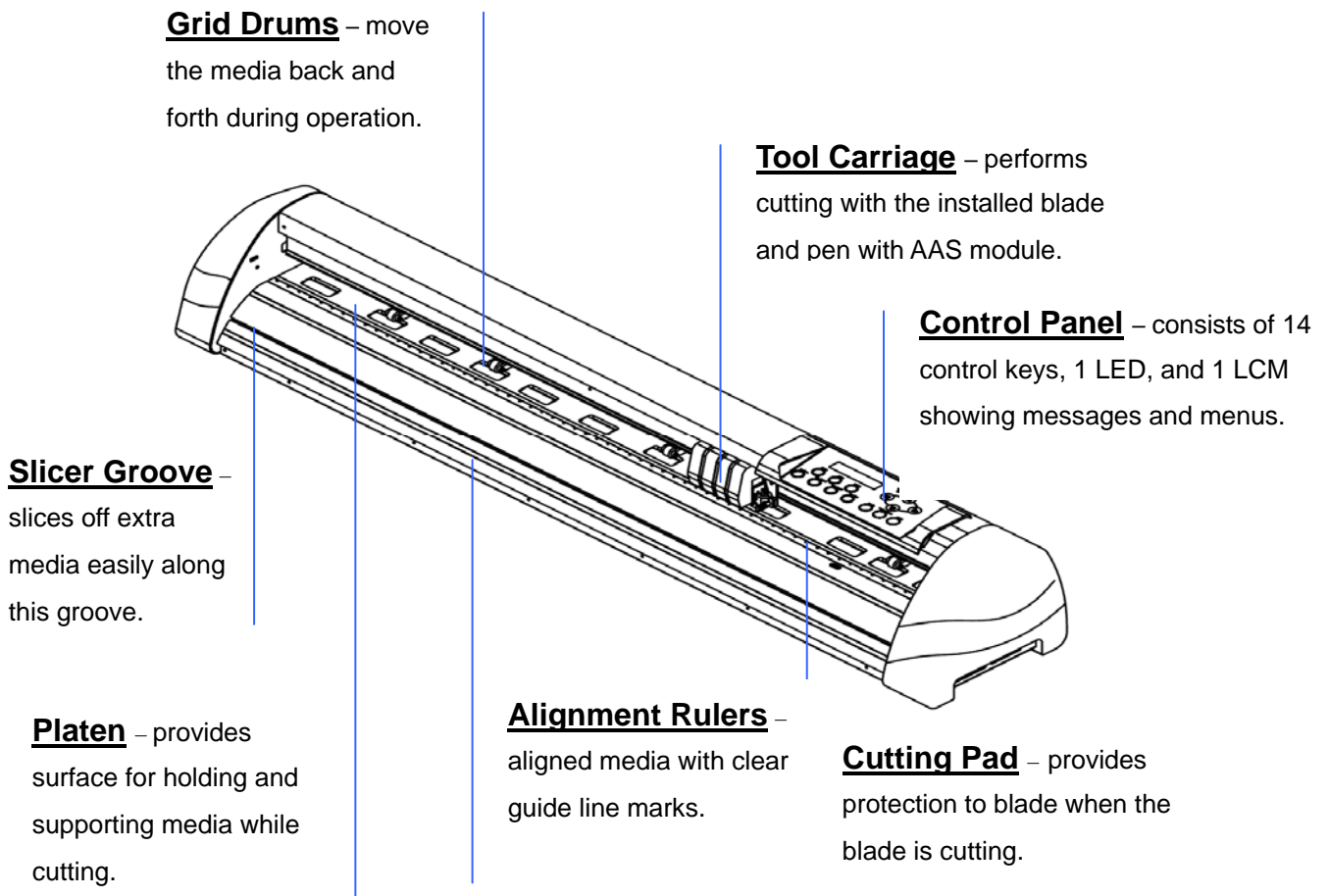

Figure 1-1

### 1.4.2 The Back View (Figure 1-2)

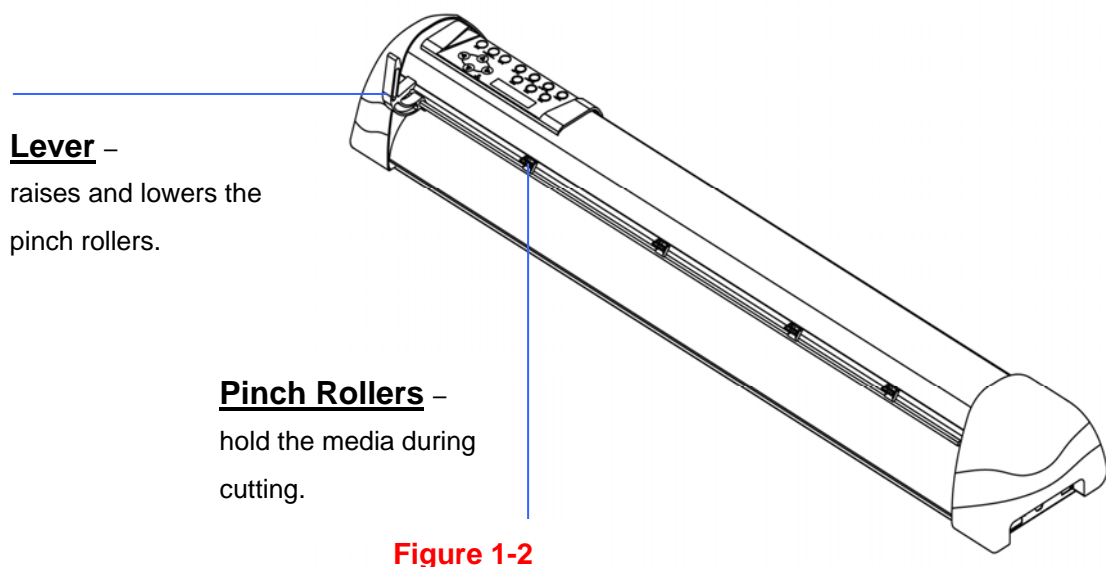
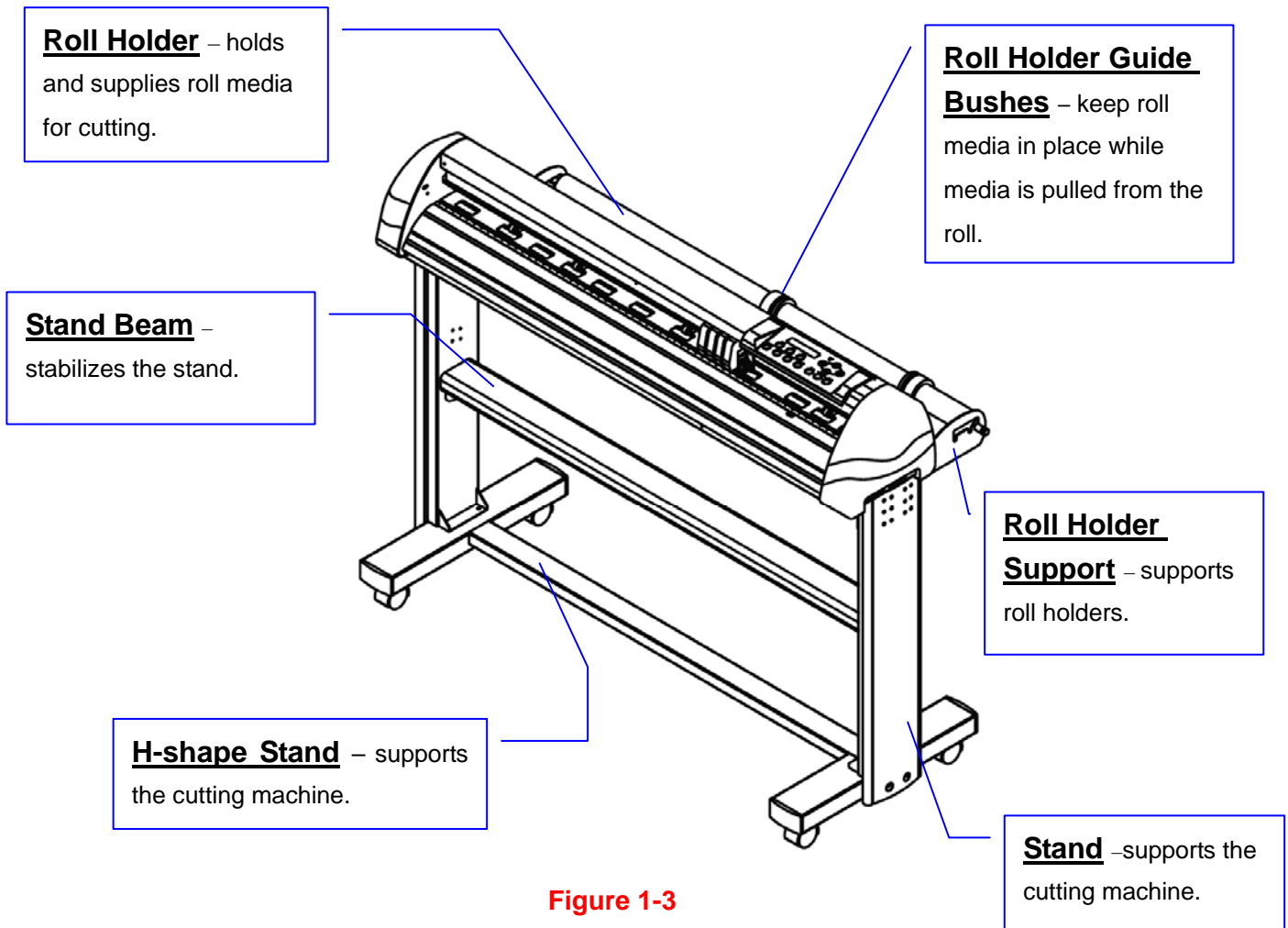
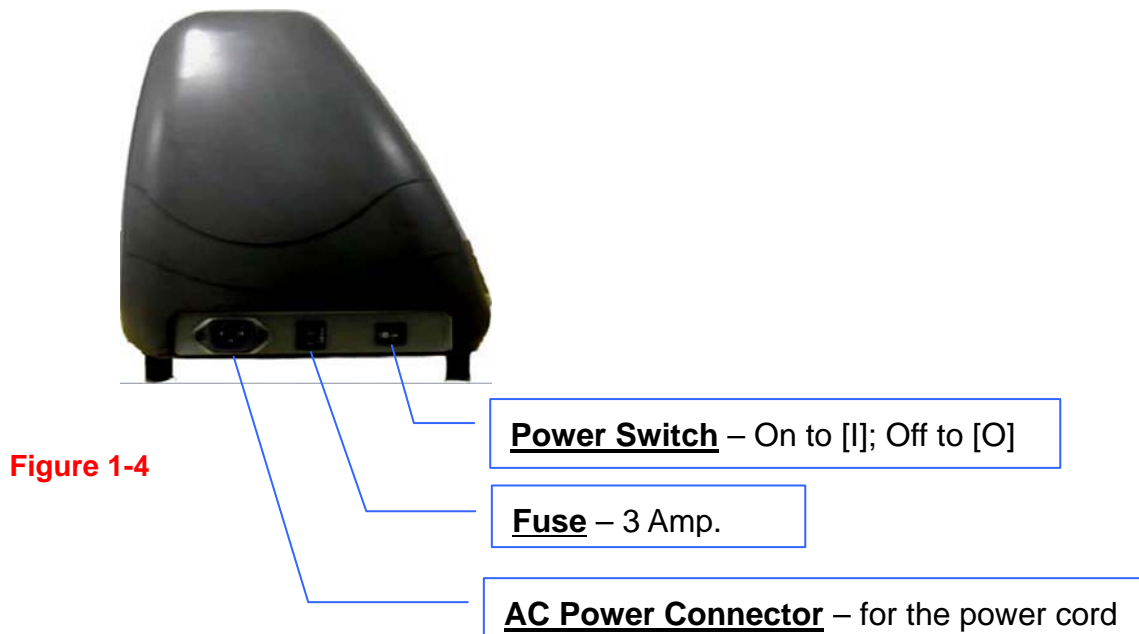

Figure 1-2

1.4.3 The Whole View (Figure 1-3)



1.4.4 The Left-hand Side (Figure 1-4)



1.4.5 The Right-hand Side (Figure 1-5)

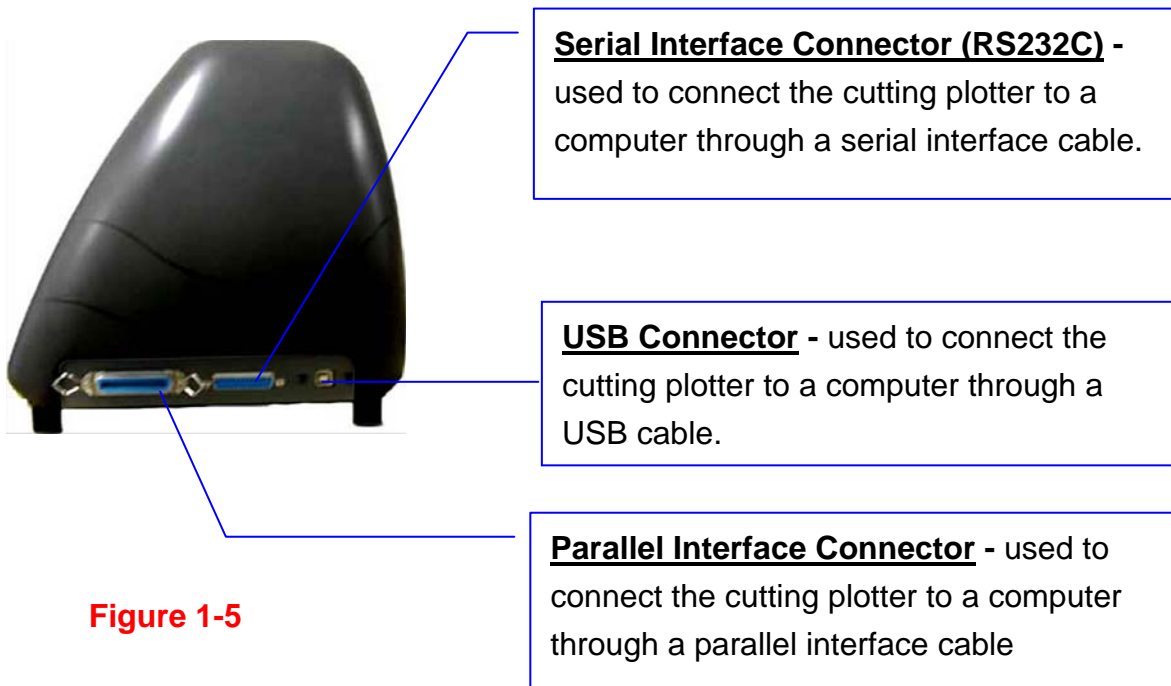

Figure 1-5

## Chapter 2 Installation

### 2.1 Precautions



Please read below information carefully before you start installation.

#### Notice 1

- Make sure the power switch is off before installing the cutting plotter.
- Carefully handle the cutter to prevent any injuries.

#### Notice 2 Choose a proper place before setting up the cutting plotter

Before installing your cutting plotter, select a suitable location, which meets the following conditions.

- The machine can be approached easily from any direction.
- There should be enough space for the machine, accessories and supplies.
- The working area should be stable and level, to prevent machine vibration.
- Keep the temperature between **50-95°F (10-35°C)** in the work area.
- Keep the relative humidity between **25% and 75%** in the work area.
- Protect the machine from dust and strong air currents.
- Do not place the machine in direct sunlight or extremely bright lighting.

#### Notice 3 Connecting the Power Supply

The power cord included is compatible with standard AC 100-240V wall outlets, standard within the United States. Check ZenCut Black Specifications for compatibility.

- Insert the plug (male) into a grounded power outlet.
- Insert the other end (female) of power cord into the AC connector of cutting plotter.

## 2.2 Stand & Flexible Media Support System (for ZCB-101S/132S/183S)

### Step 1

Please review the supplied items in the accessory box of stand carton:

- 1 M6 L-shape hexagon screw driver
- 1 M5 L-shape hexagon screw driver
- 24 M6 screws
- 4 hold plugs
- 4 Stand Wheels
- 1 Installation Guide for Stand Set

### Step 2

- Place the stands upright on the H-stand and follow the number ①②③ to assemble.  
(See Figure 2-1 & 2-2)

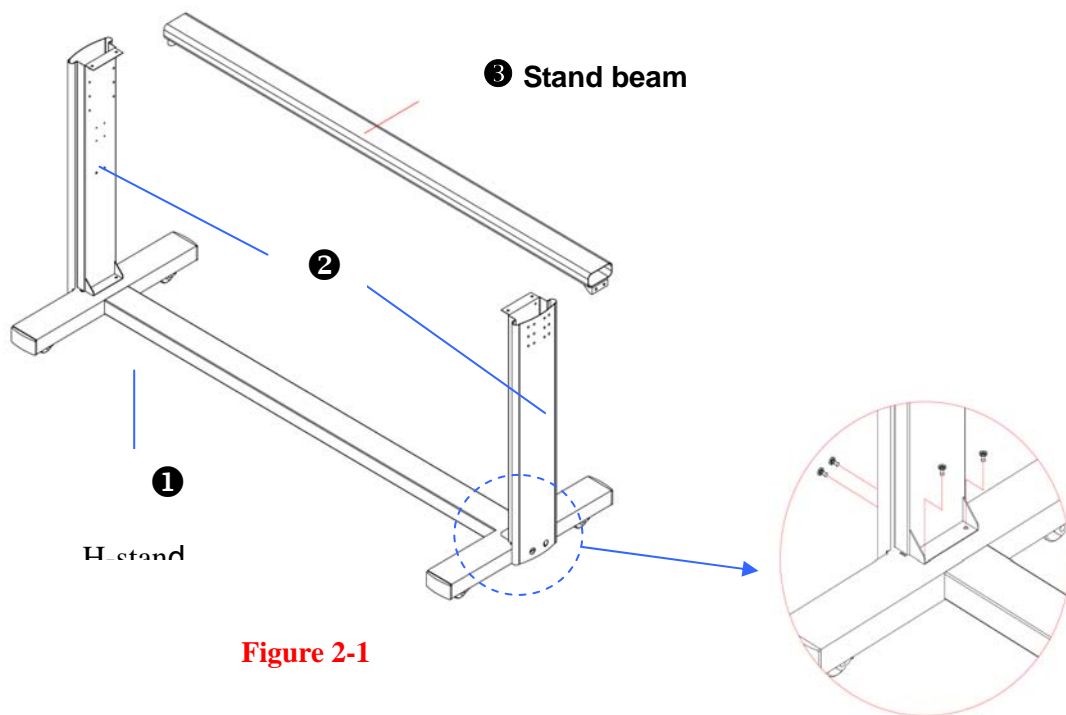

Figure 2-1

Figure 2-2

**Step 3**

Then, connect Part ② and ①. Insert 4 screws into the holes on H-stand and fasten them as shown in Figure 2-2.

**Step 4**

Position the stand beam perpendicularly to part ② and place the screws into the holes. Tighten them as Figure 2-3. The complete picture of stand will look like **Figure 2-4**.

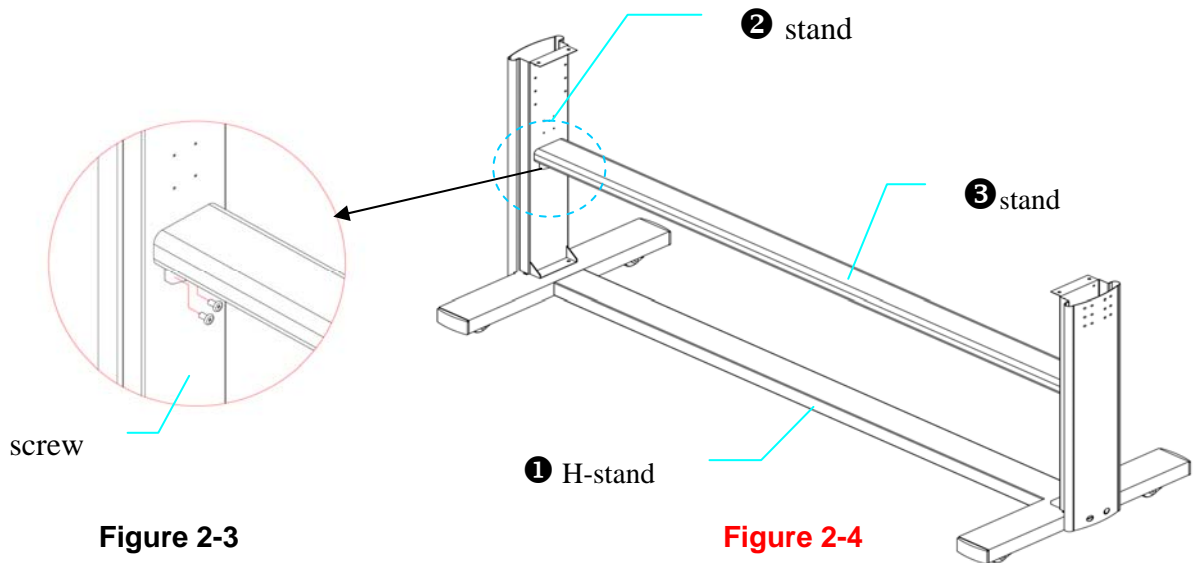

**Step 5**

Remove the cutting plotter from the carton. Position your stand under the plotter, and then insert the screws into the holes on bottom of plotter. Tighten them as shown in **Figure 2-5**.

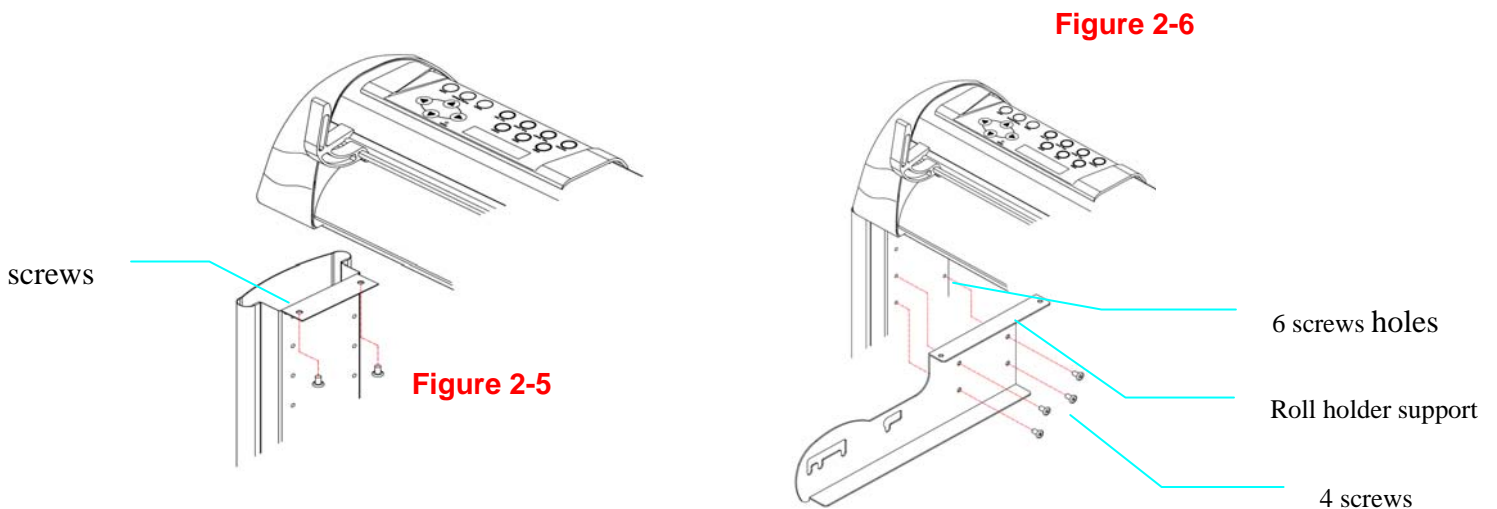

**Step 6**

Insert the roll holder support with the screws into the holes of the stand, then tighten them up as shown in **Figure 2-6**. You can change decide roll holder support's position by inserting into different holes.

**Step 7**

Place two roll holders into the holes in the roll holder support (**Figure 2-7**)

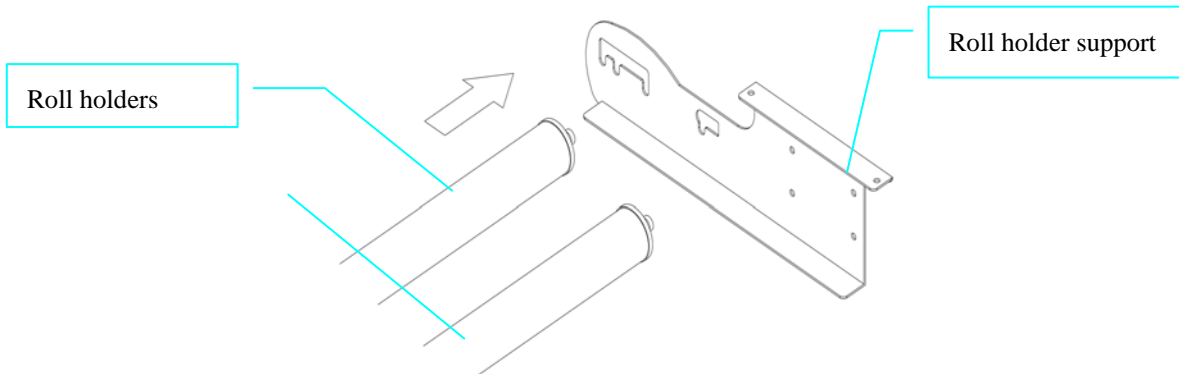

**Figure 2-7**

**Step 8**

The fully assembled plotter is shown below. (see **Figure 2-8**)

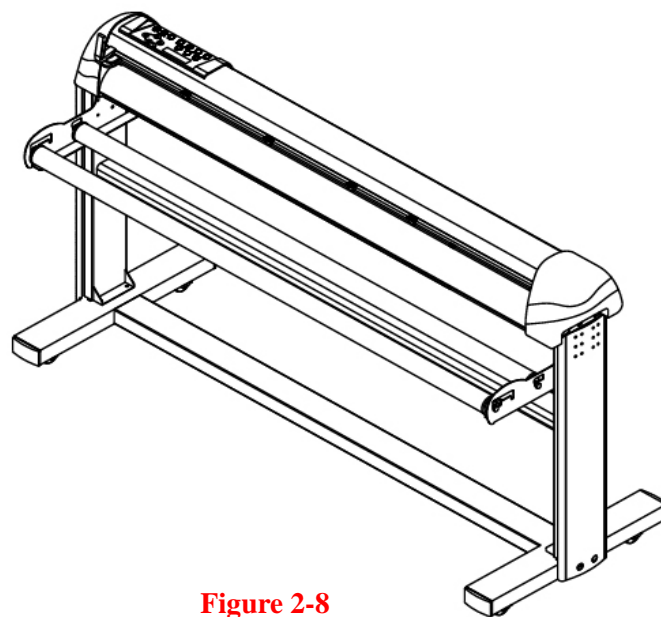

**Figure 2-8**

## 2.3 Desktop Flexible Media Support System (For ZCB-61 only)

### Step 1

Please review the following items in stand carton's accessory box:

- 1 set of Roll Media Flange (2 pieces)
- 1 set of Roll Holder (2 pieces)
- 1 set of Roll Holder Guide Bushes (4 pieces)
- 1 set of Roll Holder Support (2 pieces)
- 1 set of Desktop Support Bracket (2 pieces)
- 4 Plastic Feet
- 4 M4 screws
- 12 M6 screws
- 1 M4 L-shape hexagon screw driver
- 1 M5 L-shape hexagon screw driver
- 1 M6 L-shape hexagon screw driver (for adjusting the screws of Roll Holders)
- 1 Installation Guide for Roll Holder

### Step 2

Put the 4 Plastic Feet under the Roll Holder Support and insert the M4 screw into the hole of Plastic Foot. Tighten them with the M4 L-shape screw driver. (Figure 2-7)

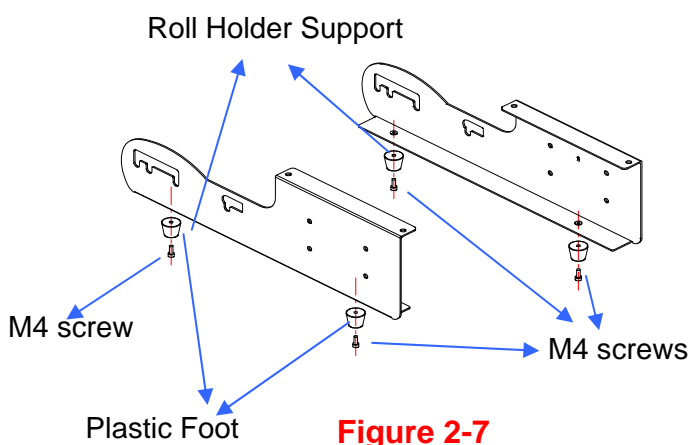

**Figure 2-7**

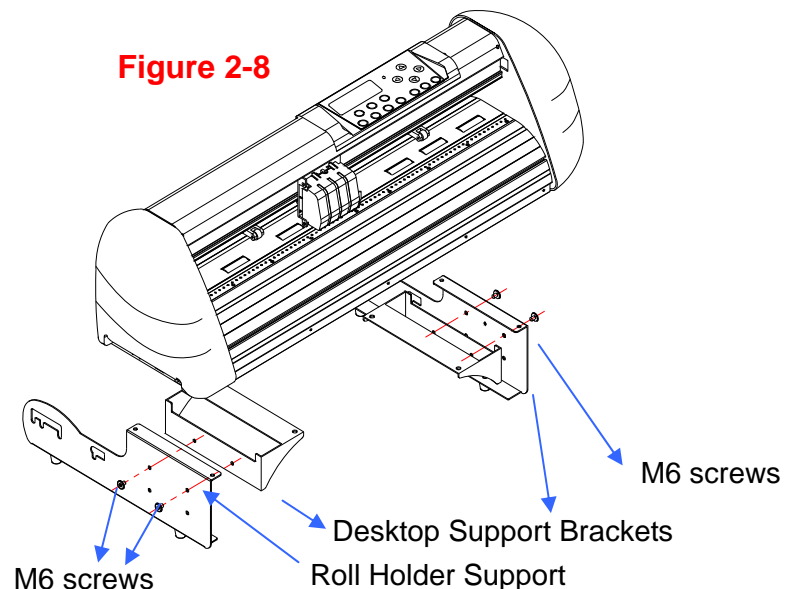

**Figure 2-8**

**Step 3** Position the Desktop Support Brackets beside the Roll Holder Support and insert M6 screws into the Roll Holder Support. Tighten them with M6 L-shape screw driver. (Refer to Figure 2-8 at the left).



**Step 4**

Carefully tip the machine onto its side, and position the Roll Holder Assembly beside the bottom of the machine. Then, insert the M6 screws into the holes of Roll Holder support assembly and tighten them with M6 L-shape screwdriver. Like Figure 2-9.

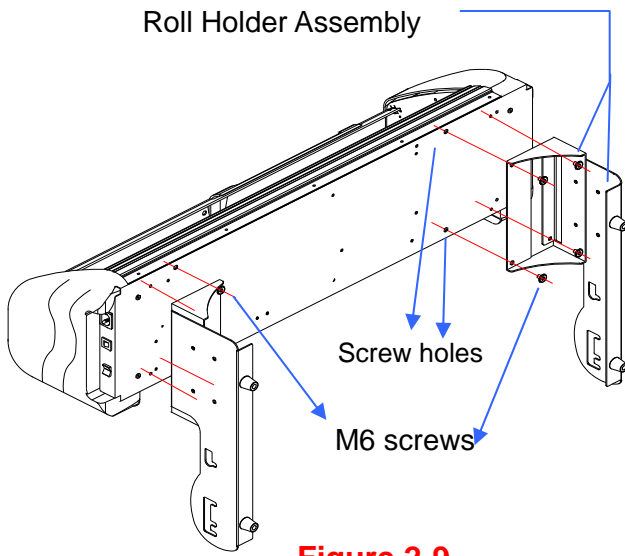

**Figure 2-9**

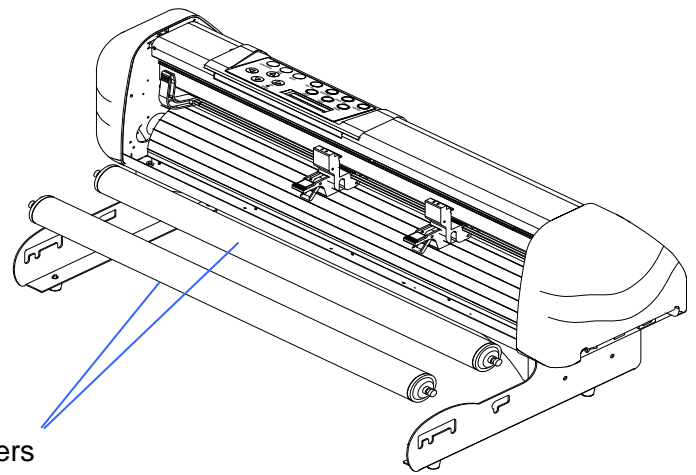

**Figure 2-10**

**Step 5**

Place the two roll holders into the holes of Roll Holder Support (Figure 2-10).

**Step 6**

The complete Desktop Media Support System will look like Figure 2-11.

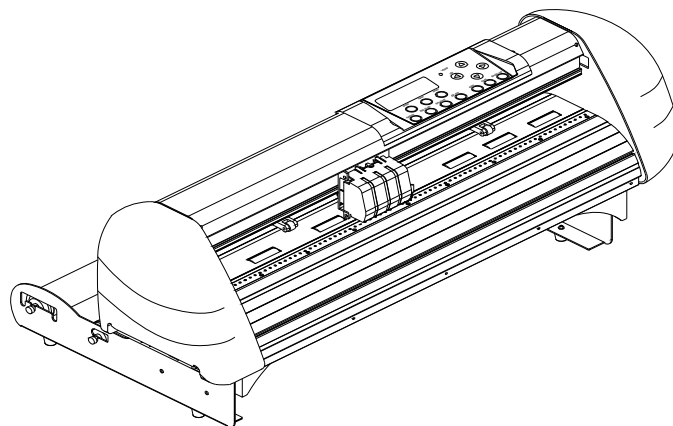

**Figure 2-11**

## 2.4 Blade Installation

Figure 2-12 is the illustration of the blade holder. Insert a blade into the bottom of the blade holder. Remove the blade by pushing the pin. Make sure that your fingers are away from the blade tip.

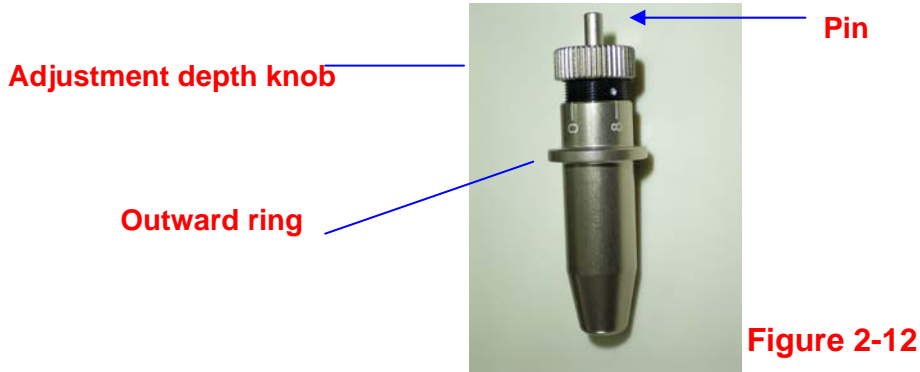

### Step 1

Install blade (Figure 2-13).



Figure 2-13



Figure 2-14

### Step 2

Push the blade to the bottom of the blade holder. (Figure 2-14).

### Step 3

Adjust the blade tip to suitable length by rotating “blade tip adjustment screw” clockwise or counter-clockwise. (Figure 2-15).



Figure 2-15

#### Tips:

“The suitable length” means the blade’s length is adjusted 0.1mm more than film’s thickness. That is, if the thickness of film is 0.5mm, then blade’s length is properly adjusted 0.6mm and it can completely cut through the film layer without cutting through backing paper.

**Step 4**

Insert the blade holder into tool carriage. Please note the outward ring of the holder must be put into the grooves of carriage firmly (see Figure 2-16), then fasten the case (Figure 2-17).



**Figure 2-16**



**Figure 2-17**

**Step 5** Reverse the steps mentioned above to remove the blade holder.

**Step 6** Press the push-pin to remove the blade from the blade holder when replacing blade.

**Caution**

The blade will lose its sharpness after a period of usage, and the cutting quality might be affected. By increasing the cutting force, the blade may still cut. However, once the blade is no longer provides a reliable cutting, you should replace it with a new one. The blade is a consumable item and must be replaced as often as necessary to maintain the cutting quality. Be sure to use a high quality blade to ensure good cutting results.

## 2.5 Cable Connection

The cutting plotter communicates with a computer through a **USB (Universal Serial Bus)**, **Parallel port (Centronics)**, or **Serial port (RS-232C)**. This chapter shows you how to connect the cutting plotter to a host computer and how to set up the computer/cutting plotter interconnection.

---

**!! Notice:** When USB connection is enabled, both parallel port and serial port will be disabled automatically.

---



Figure 2-18

### 2.5.1 USB Interface

ZenCut Black's built-in USB interface are based on the Universal Serial Bus Specifications Revision 1.1. (Operation systems Windows 95 and Windows NT do not support USB).

#### ■ USB driver installation

**Caution!! Do not plug USB cable into plotter before you install USB driver.**

- a. Put USB cable aside (don't plug it into ZenCut Green).
- b. Insert "User CD", and then click on "USB driver" to install USB driver. USB driver will remove drivers which occupy USB port first, then install ZenCut Green USB driver. The USB driver was installed successful when a popup window shows "USB Driver installed".

#### ■ Connection

Plug the USB cable into the ZenCut Black USB interface connector. Plug the other end of the cable into the PC's USB interface connector.

#### ■ Cutting driver or sign cutting software installation

Insert "User CD", and then click on "Driver" to install driver working with CorelDraw or your own sign-making software.

### 2.5.2 Parallel Interface

#### ● Connecting to the Parallel (Centronics) Port

1. Connect a parallel cable to the cutting plotter and the host computer.
2. Set up the output port **LPT1** or **LPT2** from your software package.
3. Send the data to your cutting plotter directly. Or, use DOS commands like **TYPE** or **PRINT** to output data.

**Caution!! Please turn off the plotter before plugging the print cable.**

### 2.5.3 RS-232 Interface

- Connecting to the RS-232 (Serial) Port
1. For IBM PC, PS/2 users or compatibles, connect the RS-232C cable to the serial connector of the assigned serial port (COM1 or COM2) of your host computer.
  2. Set up the communication parameters (Baud Rate and Data Bits/Parity) to match the setting of software package, refer to chapter 3 – “Misc” key description.

**Caution!! Please turn off the plotter before plugging the RS-232C cable.**

### 2.5.4 Data Transmitting

There are two options to transmit the data from the computer to the cutting plotter:

**Option 1:** With proper interface settings, the data can be transmitted from your application software package to the cutting plotters directly.

**Option 2:** Most cutting software packages are able to emulate **HP-GL** or **HP-GL/2** commands, therefore, use DOS commands like **TYPE** or **PRINT** to output your file. As long as the file is **HP-GL** or **HP-GL/2** format, the cutting plotter can output the data precisely.

For example, a file with **PLT** extension can be transmitted directly to the plotter at the DOS prompt, and then be cut out. Before outputting at the DOS prompt, set up a transmission protocol between your cutting plotter and computer by a DOS command, **MODE**. Make sure that your PC has the same communication protocol as the cutter. For example:

**MODE COM2: 9600, N, 8, 1, P**

Then, use **TYPE** command to output via **COM2** if **COM2** is the assigned output port.

**TYPE filename > COM2**

**Tip:**

Add the **MODE** command line to your system's **AUTOEXEC.BAT** to automatically execute **MODE** command every time you want to output your data at the DOS prompt via serial connection. However, values in a **MODE** command should comply with the related requirements of your software. Refer to DOS manual for further information.

# Chapter 3 The Control Panel

This chapter describes the button operations with the LCM menu flowcharts of ZenCut Black. When the cutting plotter is set up as described in Chapter 1 & 2, all functions are under default parameters.

## 3.1 The LCD Panel

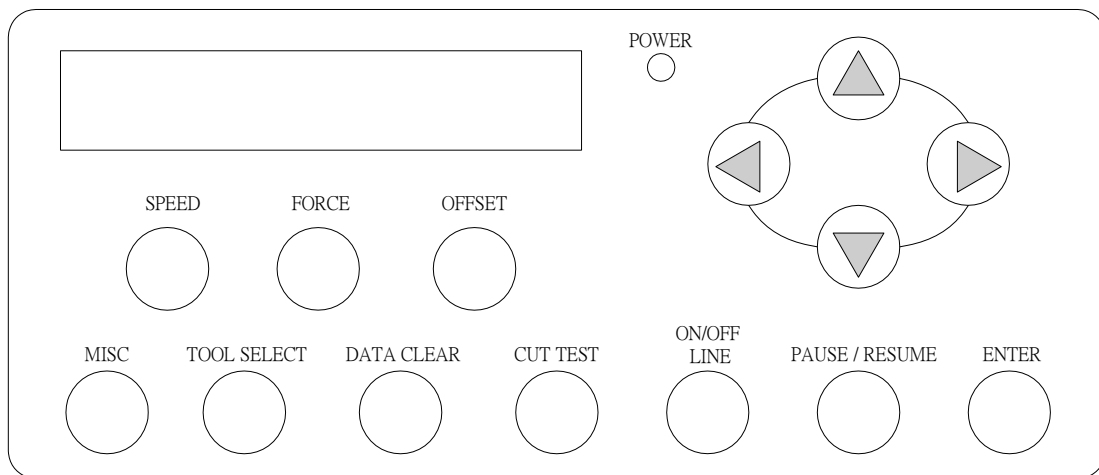

< LCD Control Panel on ZenCut Black series >

Key	Function
LCD Screen	To display functions and error messages.
Power LED	To indicate the power status ( light up: power on; light off: power off )
4 Arrow Keys	To move position, select function, or change setting.
ENTER	To set item or register the immediately preceding input value.
PAUSE/RESUME	To temporarily halt cutting process or to continue
ON/OFF LINE	To switch modes, stop cutting job, or abort changes of settings.
OFFSET	To adjust the value of blade's offset.
FORCE	To adjust the value of cutting force.
SPEED	To adjust the value of cutting speed and quality.
CUT TEST	To perform cutting tests in different ways.
DATA CLEAR	To clear up buffer memory.
TOOL SELECT	To select tools.

**MISC** To set up functions.

Please see details in "3.4 Menu Items"

### 3.2 Menu in On-line Mode

**Power On** ZenCut Black in processing

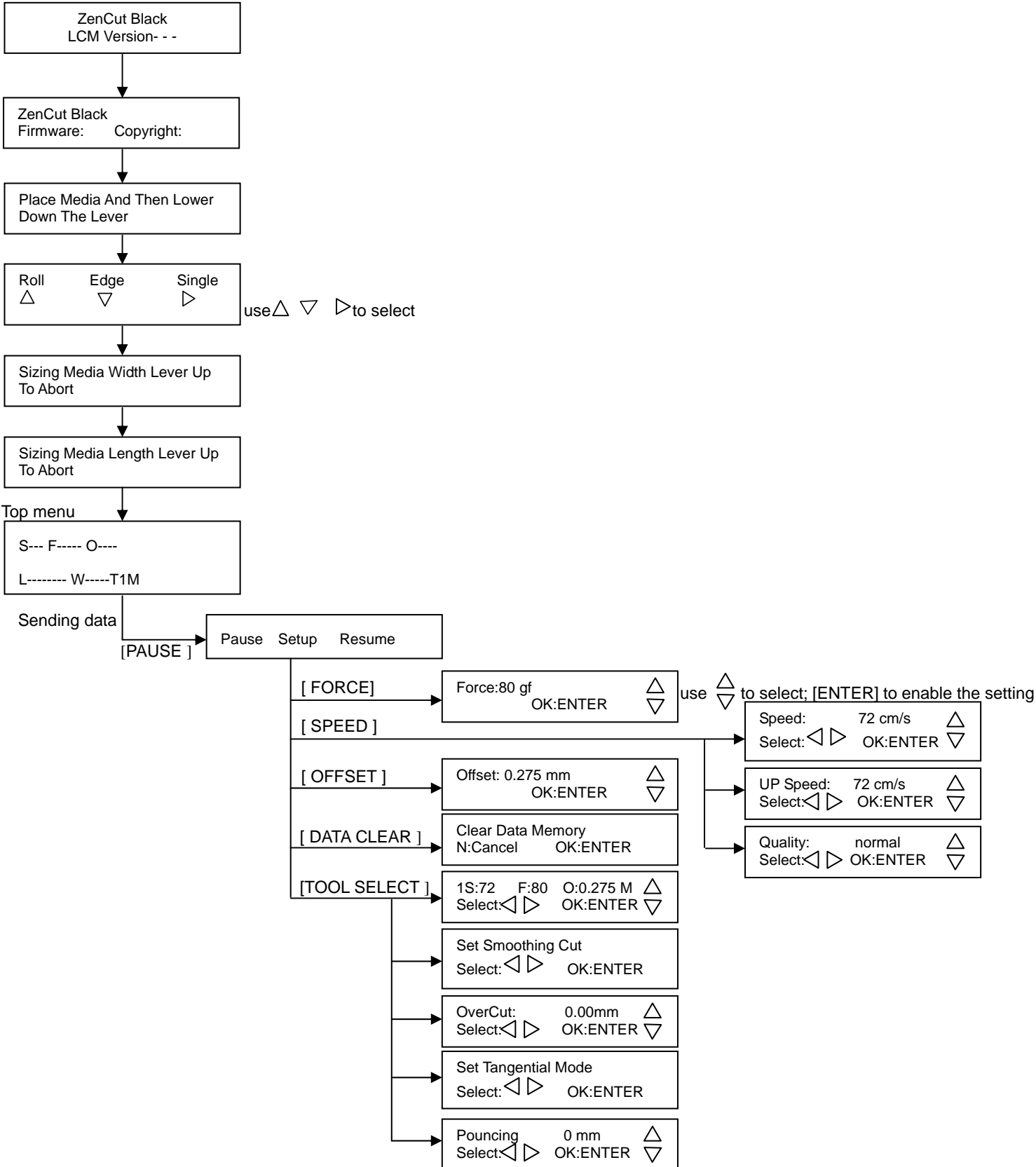

### 3.3 Menu in Off-line Mode

Press [ON/OFF LINE] to switch to the offline mode

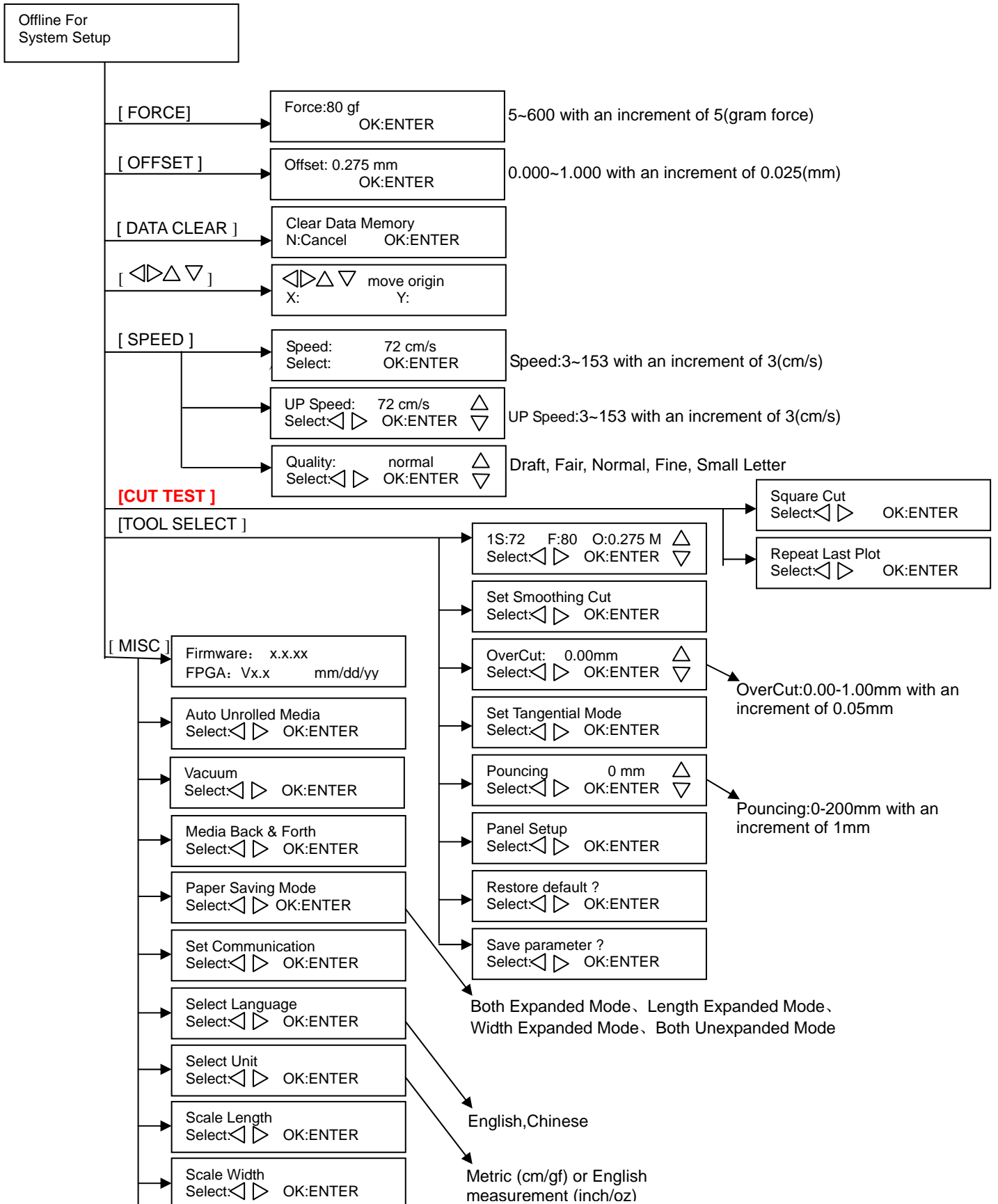



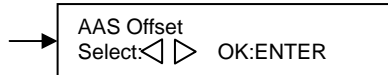

### 3.4 Menu Items

Below describes the functions of menu items

Menu or Key	Function	Setting	Default
<b>--- Media sizing ---</b>			
Roll	To measure media width.	Maximum Tracking 150 meters	
Edge	To measure media width and pull media back until front paper sensor opens.	Maximum Tracking 150 meters	
Single	To measure media width and length.	Maximum Tracking 10 meters	
<b>--- POWER ---</b>			
	To indicate the power status.		
<b>[ Arrow Keys ]</b>			
	1. To move the tool carriage position on X or Y axis. 2. To select functions or change values of settings.		
<b>[ ENTER ]</b>			
	1. The displayed parameters will be saved automatically. 2. To set a new origin at the present tool carriage position. In "offline" mode, moving the tool carriage to desired position by [Arrow Keys], then press [ENTER] key to set a new origin. While moving with the parameters of XY-axes displayed, press [MISC] key will enable fine-tune movement; press [MISC] key again to disable the function.		
<b>[ PAUSE/RESUME ]</b>			
	To temporarily halt the cutting process. To resume the process by press [Pause/Resume] key again.		
<b>[ ONLINE/OFFLINE ]</b>			
	1. To switch between online mode and offline mode. 2. To stop the cutting job or abort changes of settings. Once this key is pressed, the cutting job will be terminated immediately and cannot be resumed.		
<b>[ OFFSET ]</b>			
	To set or modify the distance between the blade tip and the center axis.	0.000~1.000mm	0.275mm
<b>[ FORCE ]</b>			
	To set or modify the value of tool force.	5~600gram; 5 gram/per step	80 gram
<b>[ SPEED ]</b>			
Speed	To set or modify horizontal tool speed.	3~153cm/sec; 3cm/sec per step	72cm/sec
Up Speed	To set or modify vertical tool speed.	3~153cm/sec; 3cm/sec per step	72cm/sec
Cutting Quality	To set or modify cutting quality. While cutting small letters, set as "Small letter". While cutting in high speed, set as "Draft". For normal operation, set as "Normal".	Draft, Fair, Normal, Fine, Small Letter	Normal
<b>[ CUT TEST ]</b>			

Square Cut	To perform a cutting test at present blade position. For more information, please refer to “4.3 Adjusting the Cutting Force and Offset” to adjust blade force and cutting speed.		
Repeat Last Plot	Recut: To repeat the last job without re-sending the data.	1~99; 1 per step	
	Copy: To copy the last job without re-sending the data.  * 1mm gap will be auto-generated between 2 copies). * If the media length is not enough to continue, it will show below message on LCM:  <div style="border: 1px solid black; padding: 5px; display: inline-block;">O u t O f S p a c e ; # o f C o p i e s f i n i s h e d</div>  * If both functions are enabled at the same time, the cutter will perform the last setting only.	1~99; 1 per step	
<b>[ DATA CLEAR ]</b>			
	To clear buffer memory.		
<b>[ TOOL SELECT ]</b>			
Set Smoothing Cut	To enable smooth-cutting function.		Enable
Over Cut	To generate an overcut to facilitate weeding.	0.00mm-1.00mm 0.05mm/per step	0.00mm
Set Tangential Mode	To enable the emulated tangential-cutting mode for thicker media types and small letter cuts. Note: While the Offset value setting at 0.000 mm, “Set Tangential Mode” will automatically be disabled.		Enable
Pouncing	To make perforated patterns. * In order to use this function, Pouncing tool must be installed. * Before Pouncing, place pouncing strip on top of the cutting pad to protect it. * Set the value as 0 mm to disable Pouncing mode. * Pouncing tool is an optional item.	0~200mm	0mm
Panel Setup	Accept setup command: To accept commands of the Force, Speed, Cutting Quality, and Offset only via software.		
	Control panel only: To accept commands of the Force, Speed, Cutting Quality, and Offset only via control panel of the cutter.		
Restore Default	To turn all parameters of the menu items to factory-default settings.		
Save Parameter	To save pattern(s) of cutting parameters for later use.	Patterns1~4	Pattern 1
<b>[ MISC ]</b>			
Auto Unrolled Media	To avoid paper jam and motor crash by automatically unrolling media (50cm and up) before cutting (while enabled). * Auto-unroll only applies to roll/edge media. * Using Single mode to size media will disable this function automatically. * If the length of the rolled media is less than 2 meters or the weight is light, it is recommended to disable this mode.		Enable

Vacuum	To help improve tracking and cutting accuracy by turning on the fans. If you turn off the vacuum system, the fans will remain inactive during cutting or plotting.		Enable
AAS Offset	To set or modify AAS offset value. You can refer to "5.3 Printer Test" for more details.		
Media Back & Forth	To save time on repeated cutting jobs and get better tracking. After cutting job has finished, the media will move back to the origin, then move to the end of the plot.		Disable
Paper Saving Mode	To save media by four different modes: 1. Length expanded mode    2. Width expanded mode 3. Both expanded mode      4. Both unexpanded mode		Both unexpanded mode
Set Communication	To build up the communication between host computer and cutter. <i>Baud Rate</i> is to determine the speed of data transmission. <i>Data Bits</i> refers to the size of one block of data. <i>Parity</i> is used to check if data was received correctly or not. 9600, n, 7, 1, p      9600pbs, 7 Bits with NO Parity 9600, o, 7, 1, p      9600pbs, 7 Bits with ODD Parity 9600, e, 7, 1, p      9600pbs, 7 Bits with EVEN Parity 9600, n, 8, 1, p      9600pbs, 8 Bits with NO Parity 9600, o, 8, 1, p      9600pbs, 8 Bits with ODD Parity 9600, e, 8, 1, p      9600pbs, 8 Bits with EVEN Parity 19200, n, 7, 1, p      19200pbs, 7 Bits with NO Parity 19200, o, 7, 1, p      19200pbs, 7 Bits with ODD Parity 19200, e, 7, 1, p      19200pbs, 7 Bits with EVEN Parity 19200, n, 8, 1, p      19200pbs, 8 Bits with NO Parity 19200, o, 8, 1, p      19200pbs, 8 Bits with ODD Parity 19200, e, 8, 1, p      19200pbs, 8 Bits with EVEN Parity		
Firmware Version	To display the version number of Firmware and FPGA code.		
Select Language	To select displayed languages on LCM panel in English, Spanish, Italian, Deutsch, Japanese, Portuguese, Polish, Turkish or French.		English
Select Units	Provide two-unit systems for users convenience.	cm/gram; inch/oz	Metric
Scale Length	To adjust the scale of media length and width that may change with the thickness of the media.  The Denominator is the actual length, and the Numerator is the ideal length measured from the resultant.  For example, cutting a line with 500.0 mm length. The procedure as follows:		
Scale Width	1. Press the [LEFT ARROW] to choose the Numerator and select 500.0 mm, 2. Cut the length by sending a graph file, 3. Measure the length then use the [RIGHT ARROW] key to choose the Denominator, then 4. Press [UP ARROW /DOWN ARROW] to change the values of the actual length.		

## Chapter 4 Operation

### 4.1 Media Loading

#### 4.1.1 Loading the Sheet Media

To load the media properly, please follow the procedures listed below:

##### Step 1

Use the lever on the upper right side of the cutting plotter to raise or lower down pinch rollers. Pull the lever forward until it makes a clicking sound then the pinch rollers are raised (Figure 4-1).

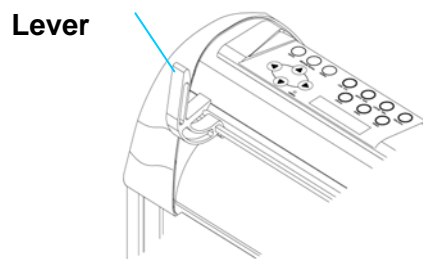

Figure 4-1

##### Step 2

Load your media on the platen and slide it under the pinch rollers from either the front side or the backside. The **alignment rulers** on the platen extension will help you to adjust the media precisely.

##### Note:

When loading the media, be sure that the media must be covered by the paper sensors on the platen. At least one of the two paper sensors (Figure 4-2) should be covered. Once the media covers the sensor, the cutting plotter will size the media width and length automatically.

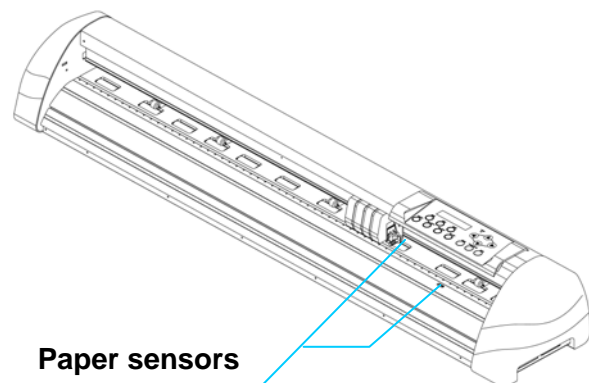
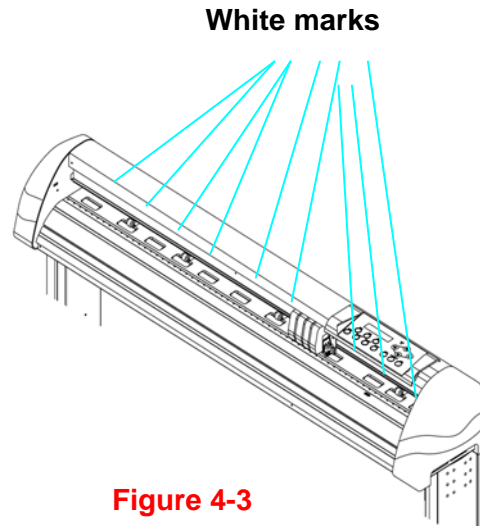

Figure 4-2

**Step 3**

Move the pinch rollers manually to the proper position. Be sure the pinch rollers are positioned above the grid drum. The **white marks** on the top rail will remind you where the grid drums are (Figure 4-3).

**Figure 4-3****Step 4**

Push the lever backward to lower down the pinch rollers.

**Step 5**

Turn on the power. The tool carriage will measure the size of the media automatically.

**Note:**

1. Always adjust the position with the pinch roller raised.
2. Move the pinch roller by applying force at the rear portion of the pinch roller support.
3. **Do not** move the pinch roller by holding the front rubber roller (Figure 4-4).

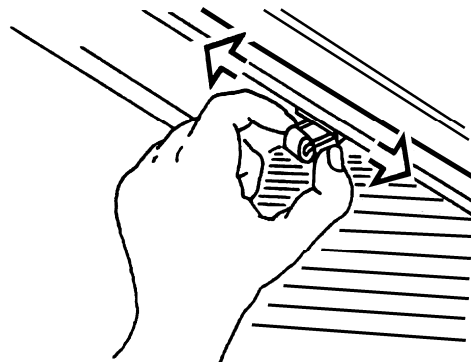
**(X)****Incorrect****Figure 4-4**

**4.1.2 Loading the Roll Media**

**Step 1**

Place the roll media guide bushes on the two roll holders (Figure 4-5).

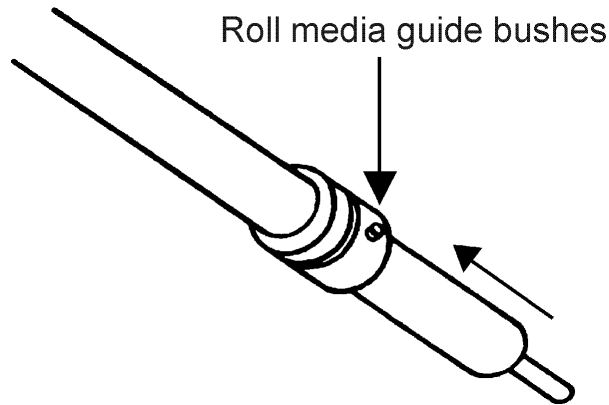
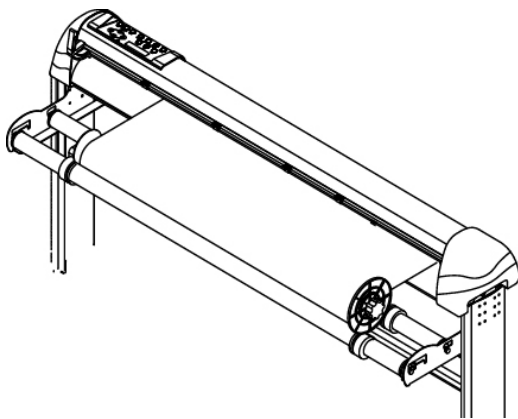

**Figure 4-5**

**Step 2**

**-- Option A (Recommended)**

Insert the two roll holders into the roll media support set, then place the roll media directly between the two roll holders (Figure 4-6).



**Figure 4-6**

**-- Option B (Use the media flanges)**

Insert a roll media flange at the end of each roll media and tighten the thumbscrew until the roll media is firmly gripped (see Figure 4-7).

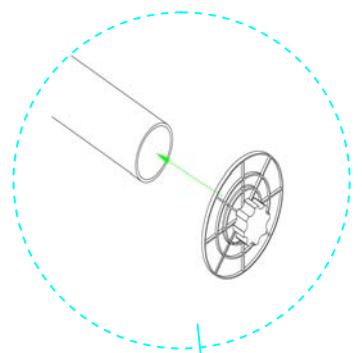

**Figure 4-7**

Then put the roll media on the roll holders. Adjust the position of the roll media so that the media flanges are able to rotate in the grooves of media guide bushes. (Figure 4-8)

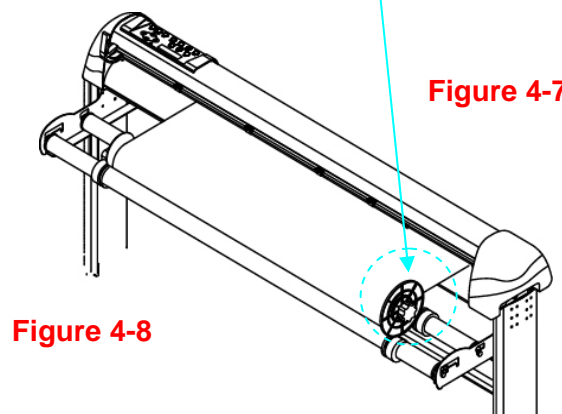

**Figure 4-8**

**Step 3**

Load the media on the platen. Please refer to “4.1.1 Loading the sheet media”. After loading the roll media, flatten the media on the platen and hold the front edge of the roll media firmly (Figure 4-9).

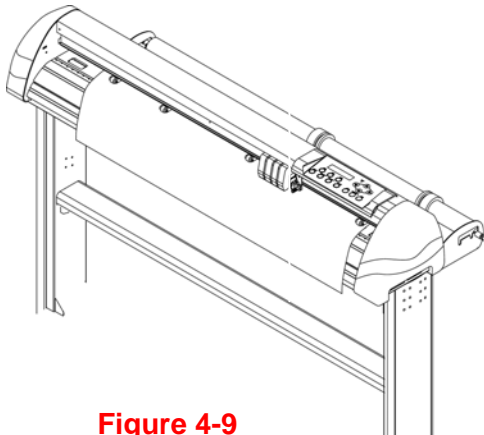
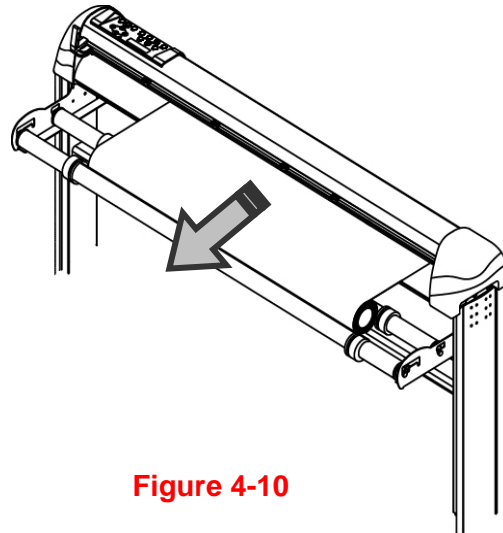
**Figure 4-9****Figure 4-10****Step 4**

Turn the roll downward to equalize tension across the media (Figure 4-10)

**Step 5**

Move the pinch rollers to the appropriate location and note that the pinch rollers must be positioned above the grid drums.

**Note :**

Make sure that the media tension is equally distributed from left to right. If the media is not taut enough against the platen, it will cause tracking problems!

**Step 6**

Push the lever backward to lower down the pinch rollers.

**Step 7**

Fix roll media guide bushes on the roll holder to secure the roll media.

**Step 8**

Turn on the power switch. The tool carriage will size the media automatically. Now the cutting plotter is ready to operate.

**Step 9**

Use the reverse steps to remove the media.

### 4.2 Tracking Performance

In order to achieve the best tracking performance for a long plot, we recommend following this procedure to load media:

If the media length is less than 13 feet (4 meters), leave the margin .01 in-1 in(0.5mm-25mm) in the left and right edges of the media (Figure 4-11).

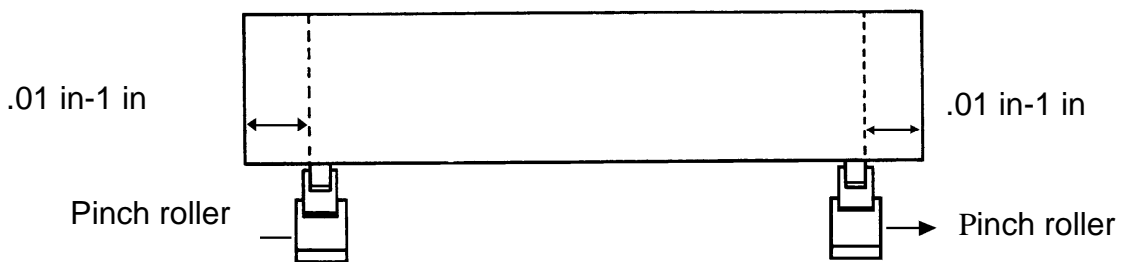

Figure 4-11

If the media length is greater than 13 feet (4 meters), leave at least 1 in (25mm) margin on the left and right edges of the media (Figure 4-12).

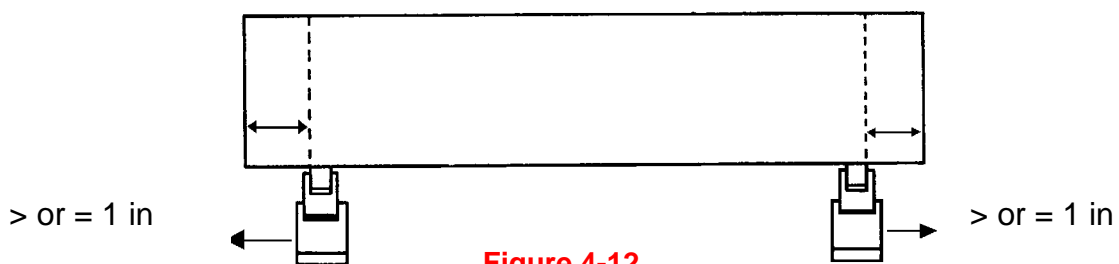

Figure 4-12

Please refer to the paragraph "4.5 How to Make A Long Plot" for more details.



### 4.3 Cutting Force and Offset Adjustment

Before sending your designs from computer to ZenCut Green for cutting, please make “Cut Test” to adjust cutting force and offset value. The “Cut Test” should be repeated several times until the optimum settings are achieved.

After sizing the media, press [CUT TEST] button to select the “square cut”, and press [ENTER KEY] to confirm.

The default cutting force and offset value of the cutting test are 80gf and 0.275mm respectively. Press [ARROW KEY] to move the tool carriage to the position where you like. Then, press the [ENTER KEY] to perform Cut Test.

Note: At the same time, the new origin is also set at the cutting test position.

When the cutting test is completed, a test cut sample design appears. Peel off the design to see if it can be easily separated from the media base. If yes, the setup tool force is appropriate. If not, or the blade has cut through the media backing, press [FORCE KEY] to adjust the tool force until an optimum force is set (Figure 4-13).

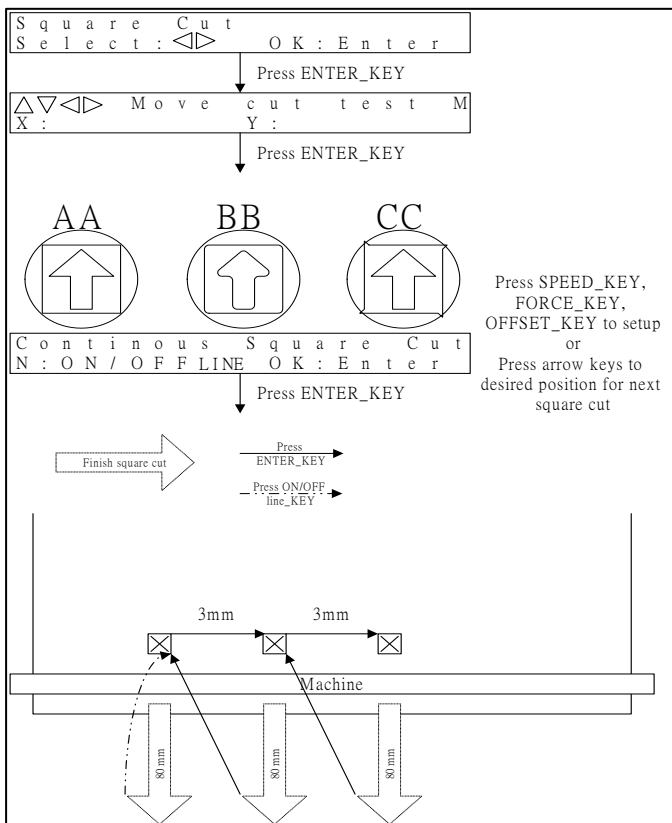

If the design appears to be BB or CC layout, press [OFFSET KEY] to adjust the offset value until AA test cut design is achieved.

Figure 4-13

## 4.4 How to Cut 3mm Letters

To obtain good quality output, narrow media is recommended. However, if wide media is used, you should:

1. Position two pinch rollers as close as possible to both edges of the cutting area.
2. Make sure the loaded media is held flat with equal tension across the platen.
3. Suggested operation settings:

Tool force: 55 gf. (or depending on the material)

Cutting speed: 45-50 cm/sec

Tool up speed: 45-60 cm/sec

Smooth cut: Disable

Quality: Small Letter

## 4.5 How to Make A Long Plot

When you are making a long plot with a roll of heavy and wide vinyl or paper, you need to use the "AUTO UNROLL MEDIA" function. The following parameter settings are to help users get the best cutting quality. The actual output quality may vary when using different kind of materials.

1. If the length of graphic is between 3m(9.84 ft) and 5m(16.4 ft), the cutting speed is better at a speed lower than 72cm/sec, with the cutting quality is set as Normal.
2. If the length is longer than 5m(16.4 ft), or if the material type is difficult to cut, it is better to further slow down the cutting speed.
3. After loading the roll media, all pinch rollers should be raised at this stage. Flatten the media on the platen and hold the front edge of the roll media firmly (Figure 4-14).

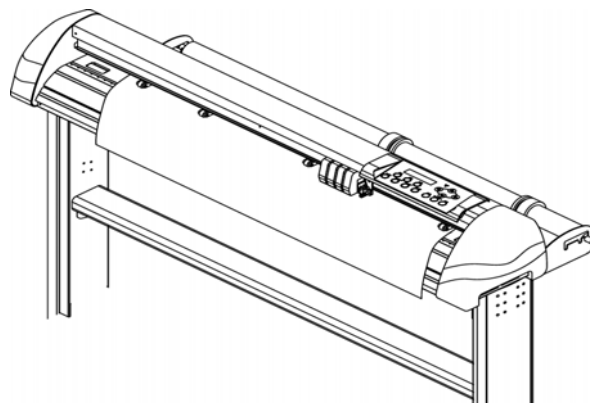

**Figure 4-14**

Then turn the roll downward to make an equal tension across the media  
(See Figure 4-15)

Make sure that the media tension is equally distributed from left to right. If the media is not taut enough against the platen, it will cause tracking problems.

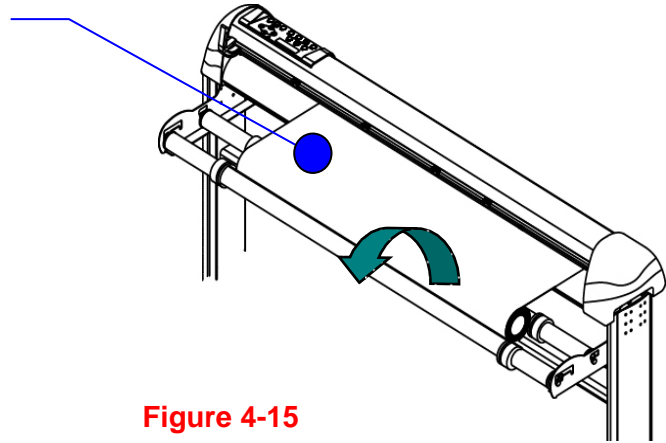

**Figure 4-15**

4. Engage pinch rollers.
5. Adjust roll media guide bushes on the roll holder to secure the roll media.
6. The protrusion length of the blade should be longer than the thickness of the vinyl. (Please check the “Blade Specification: About the Tool” in Appendix.) Once all of the above settings are correct, you’re ready to cut for large signs.

## 4.6 When Completing the Cutting Job

After completing the cutting job, raise the sheet-loading lever, and then remove the material. You can also cut off the finished job using the Safe Blade (a standard accessory) along the knife guide. (Figure 4-16)



**Figure 4-16**

## Chapter 5 Accu-Aligning System

### 5.1 Introduction

The ZenCut Black series cutting plotters feature a standard Accu-Aligning System (AAS II) to guarantee precise contour cutting quality by detecting the registration marks printed around the graphic.

#### Notice

- Eliminate light sources from the side of the AAS module, as this may interfere with operation.

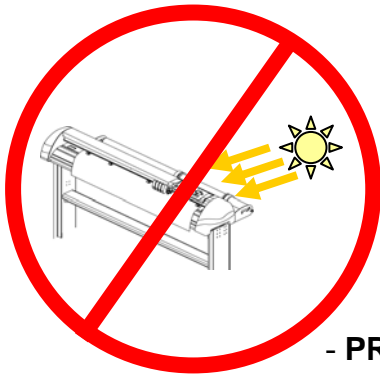

- PROHIBITED

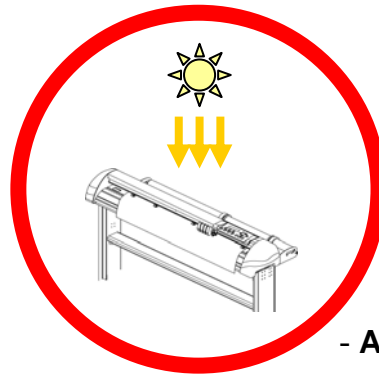

- ACCEPTABLE

- DO NOT take off the cover of AAS module while in operation.



- PROHIBITED

## 5.2 AAS Calibrating the System

The AAS system has a calibration procedure to ensure maximum accuracy. To operate the AAS, please first review the following media feeding instructions. (Refer to 4.1 Media Loading.)

### 5.2.1 Media Calibration

Media Calibration is to ensure that the sensor will be able to recognize the registration marks. The factory default works on a wide range of materials. However, certain types of materials require calibration to achieve good results. Media calibration adjusts the media feeding according to media type for better accuracy during cutting.

#### ■ When to use

We suggest white media for best cutting result. It is not necessary to perform media calibration every time unless the registration marks on the printed media become undetectable in AAS sensing process.

### 5.2.2 AAS Calibration

The first registration mark has a different design in order for AAS auto-detection to identify the origin. The following must be known for registration marks to be read automatically.

- Type of media
- Registration mark pattern
- Reading range required for detection the registration marks
- Position for registration marks and medium

The registration marks have to be:

- Created by cutting software or CorelDRAW plug-in
- Black in color
- “L” Mark Length: 10mm~50mm(.39in~1.97in), suggested 25 mm (about 1in)
- “L” Mark Thickness: 1mm~2mm, suggested 1 mm
- Margin: 1mm~50mm(.04in~1.97in), suggested 5 mm (about .2in)

The cutter cannot detect the marks when:

- Cutter carriage is not located near the outside area of first mark (See the picture in page 5-7 for auto-detecting area of first mark.)
- Medium thickness is more than 0.8mm
- Transparent medium is used
- Non-monochrome drawing. The marks can't be read if is printed on colored medium
- Dirty or creased medium surface

### 5.2.3 AAS II on ZenCut Black

There are three types of AAS II mark patterns: 4-Point Positioning, Segmental Positioning, and Multiple Copies. Note that before print out your designs using inkjet printers, the registration marks have to be created on your graphic designs by cutting software or the CorelDraw plug-in. Hand-made marks or drawings won't be reorganized by ZenCut cutting plotters. For more details about registration mark setting in cutting software, please refer to 'Appendix A-3 : CorelDraw Plug-In Instruction.'

#### 1. 4-Point Positioning

This is the basic mark pattern that AAS II will auto detect: four registration marks and contour cut images inside those marks.

- Command: Esc.D1;(XDist);(YDist):
- Layout: 4 L-shaped marks at the 4 corners around the design

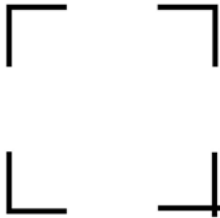

#### 2. Segmental Positioning

In addition to 4 original points, intermediate registration marks are added on both X axis and Y axis to help contour cut accurately, especially when cutting large images.

- **Command:** Esc.D2;(XDist);(YDist);(XStep);(YStep):
- **Layout:**  
 In-between distance on X: 200~600mm (7.8in~23.6in), default 300mm (about 11.8 in)  
 In-between distance on Y: 200~600mm (7.8in~23.6in), default 300mm (about 11.8 in)

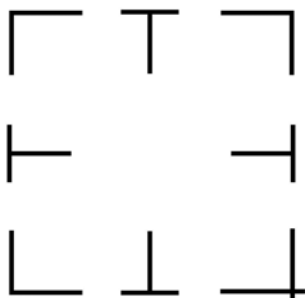

#### 3. Multiple Copies

This function is used to duplicate images so that you can cut multiple images at the same time. The AAS II sensor will automatically scan registration marks for each individual image to ensure the contour cutting precision.

- **Command:** Esc.D3;(XCopies);(YCopies);(Space):
- **Layout:**

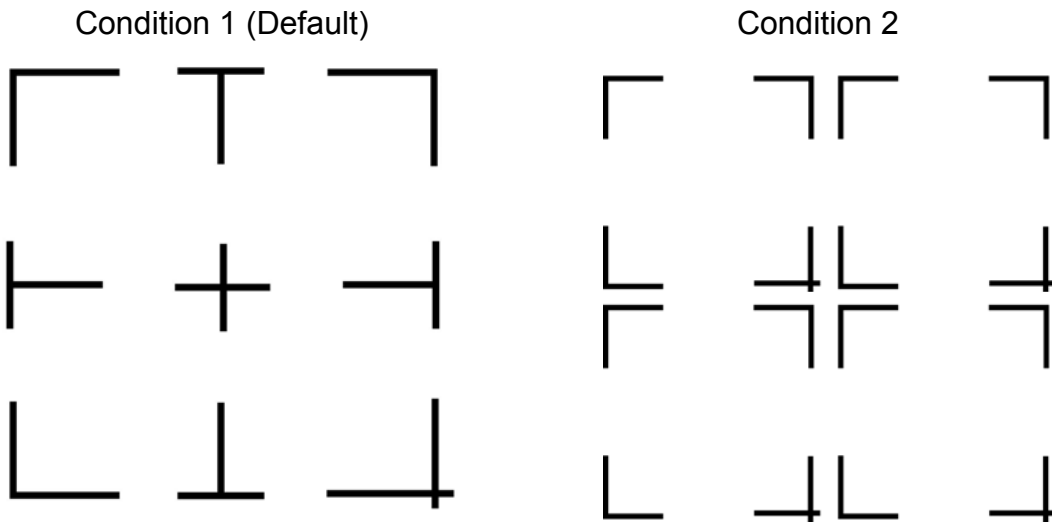

### 5.3 Printer Test

Before performing AAS contour cutting, it's recommended that you print out a test file. You can find in the enclosed User CD.

There are two testing files for AASII:

1. AAS II\_X\_Y\_Offset\_Caberation\_A4 .eps (A4 size)
2. AAS II\_X\_Y\_Offset\_Caberation\_600\_600 .eps (Default setting is recommended for testing)

- Print out the testing graphic. (Please use printer capable of printing high resolution graphics.)
- Load the graphic to ZenCut Black and send the file to test the cutting job.
- If there are any adjustments to be made, you can change the offset value by following the steps:
  - Measure the offset values from the printed line and the actual cutting line.
  - Enter the AAS Offset under MISC function for the values you just measured, then press Enter
  - Test the cutting again
  - AAS II offset X and Y value is defined as following:  
Horizontal line is defined as X and vertical is defined as Y

- When the actual cutting line and the printed line need to be changed towards the direction of origin mark, then simply add the **negative** value of the offset. If the direction is from the opposite of the origin mark, then enter **positive** values for the offset. This method applies on both X and Y axis.

**For example:**

If the values set in cutter are X: 0.50 mm Y 0.50 mm and the measurement is X1:-0.25 mm Y 1:+0.25 mm. (In following figure, the Blue Line refers to the Y Value, and the Red Line refers to the X value.)

We need to adjust AASII offset X new : (X + X1) Y new : (Y + Y1) which means X new : 0.25 mm Y new : 0.75, then save the set new value to cutter.

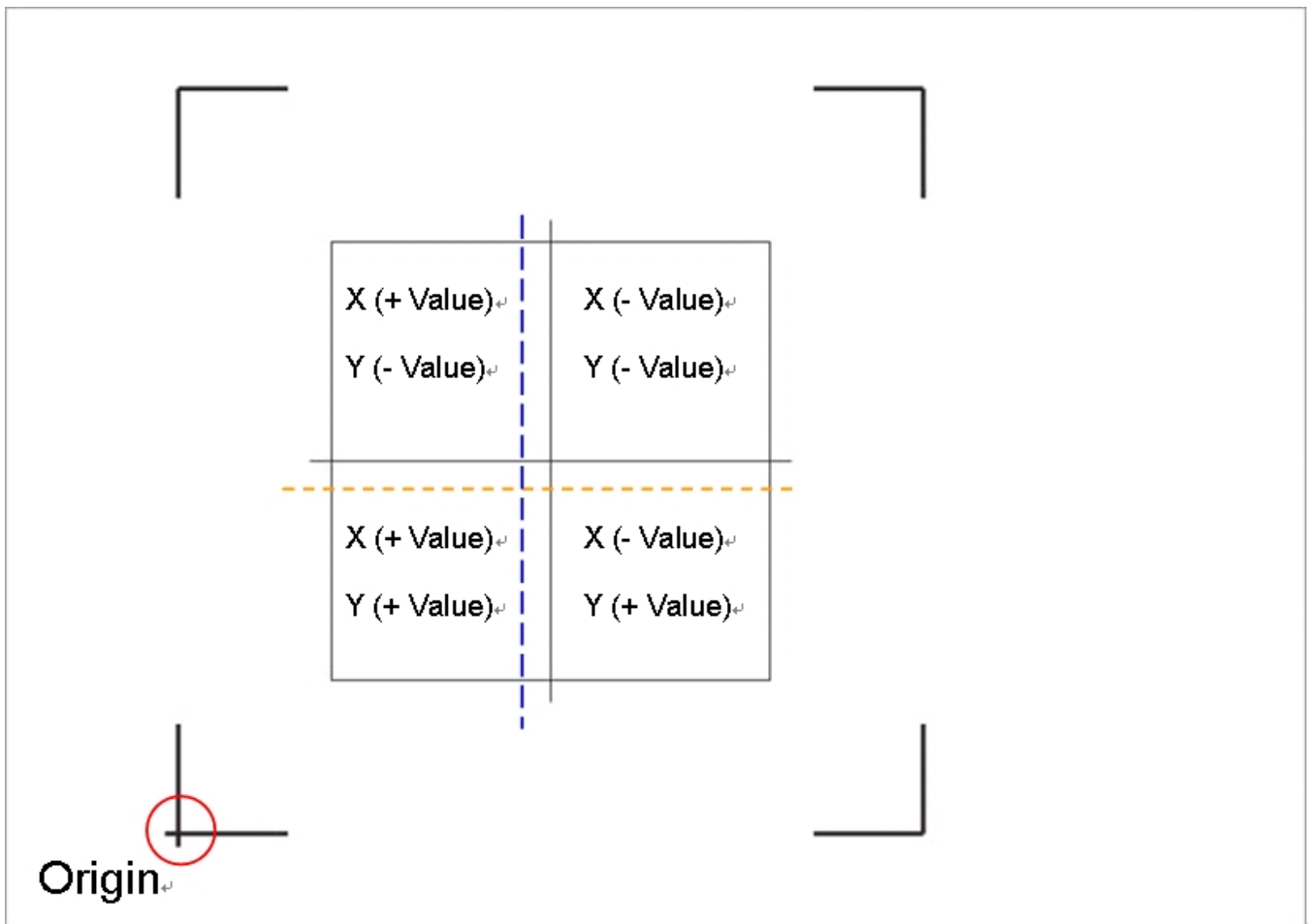

Note:

- Before adjusting the AAS II settings, please proceed with scaling for width and length.
- The blade offset value isn't set for this test graphic, please set it according to the blade you use.
- If you have any question, please contact your dealer for assistance.



## 5.4 Contour Cutting

For accurate contour cutting with AAS function, please proceed the following steps:

### Step 1 Creating Graphics

- Create the graphic that you want to print and cut in your software.



- Create a contour for cutting around the graphic.



TIP 1: Leave some space between the graphic and contour line.

TIP 2: Create the contour in a separate layer and assign a different color for it.

- Add registration marks around the graphic.

#### Note:

The Multiple Copies function is also available. It automatically copy the graphic and registration marks.

**Step 2** Placing the Registration Marks

- The AAS Layout Instruction:

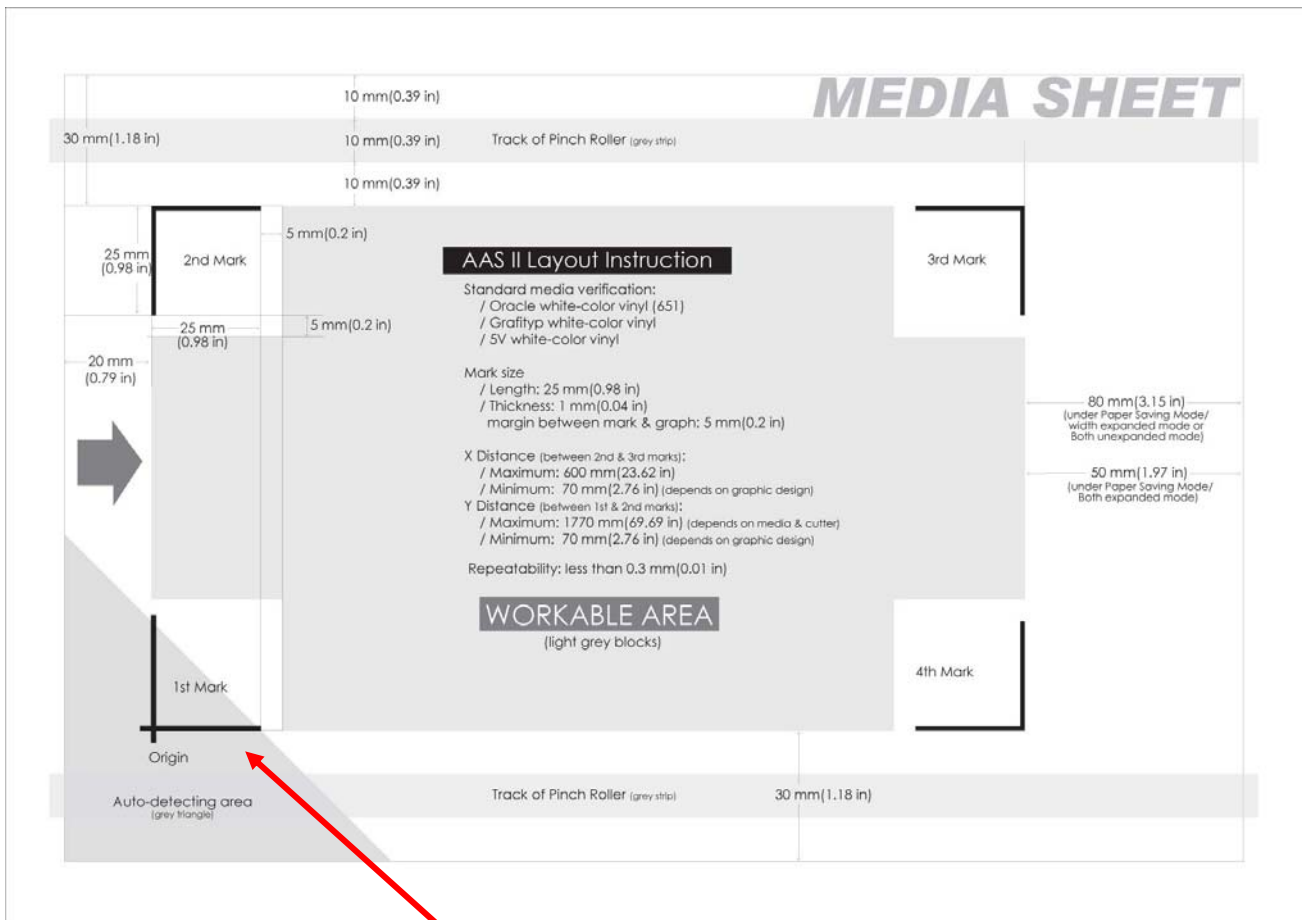

\* Auto-detection function on the 1<sup>st</sup> mark covers the grey area

- Suggested 30mm (1.18in) margin on both left and right sides of media sheet.
- Suggested 20~30mm (.75~1.18in) margin on top of media sheet, and at least 50mm margin on the bottom edge to prevent sheets dropping or any error occurred while media sizing.

**Step 3** Print the Graphics

- Print the graphic and the marks with your printer

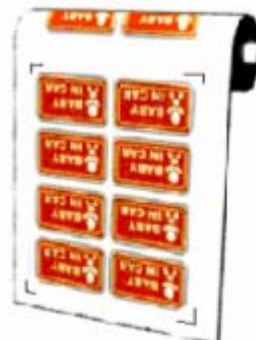

(Scaling = 100%).

- When printing on roll media, make sure the orientation is as follows:

#### Step 4 Load the printout onto cutter

- The Origin Mark is different from the rest of the registration marks. Please make sure the media is fed in the right direction.

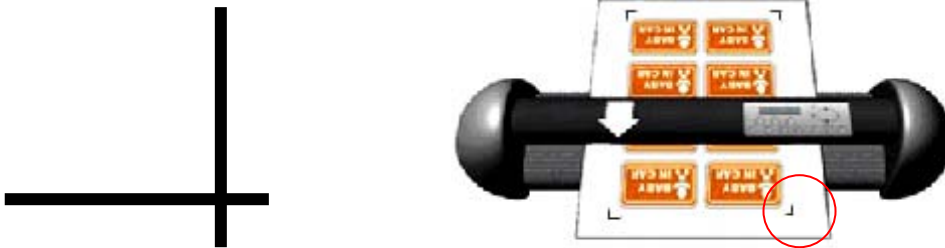

#### Step 5 Cut the Contour

- Send the command from your software to perform the contour cutting job.

## 5.5 Tips for AAS

To get the best results in contour cutting, please follow these tips:

- Keep light sources simple and avoid illuminating from the sides of cutter.
- Before operating AAS, set the appropriate maximum paper size in ZenCut Black driver property.
  - STEP 1** Find the **ZenCut Black model** in the “Printer & Fax” folder of your PC.
  - STEP 2** Open the Properties window and select the “Paper” tab.
  - STEP 3** Change the maximum Paper Size of X to **1200mm** (about 47”)
- Adjust the cutting speed to between 300~600mm/sec. (11.8~23.6in/sec)
- Avoid the registration marks located on the tracks of pinch rollers.

## Chapter 6 Basic Maintenance

This chapter explains the basic maintenance (i.e. cleaning the cutting plotter) required for the cutting plotter. Except for the below mentioned, all other maintenance must be performed by a qualified service technician.

### 6.1 Cleaning the Cutting Plotter

In order to keep the cutting plotter under good condition and best performance, you need to clean the machine properly and regularly.

#### Precaution in Cleaning



- ✧ Unplug the cutting plotter before cleaning
- ✧ Never use **solvents, abrasive cleaners or strong detergents** for cleaning. They may damage the surface of the cutting plotter and the moving parts.

#### Recommended Methods

- ✧ Gently wipe the cutting plotter surface with a lint-free cloth. If necessary, clean with a damp cloth or an alcohol-immersed cloth. Wipe with water to rinse off any residue and dry with a soft, lint-free cloth.
- ✧ Wipe all dust and dirt from the tool carriage rails.
- ✧ Use a vacuum cleaner to empty any accumulated dirt and media residue from beneath the pinch roller housing.
- ✧ Clean the platen, paper sensors and pinch rollers with a damp cloth or an alcohol-immersed cloth, and dry with a soft, lint-free cloth.
- ✧ Wipe dust and dirt from the stand.

## 6.2 Cleaning the Grid Drum

1. Turn off the cutting plotter, and move the tool carriage away from the area needed to be cleaned.
2. Raise the pinch rollers and move them away from the grid drum for cleaning.
3. Use a bristle brush (a toothbrush is acceptable) to remove dust from the drum surface. Rotate the drum manually while cleaning. Refer to Figure 6-1.

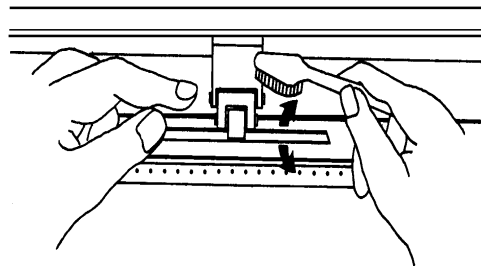

**Figure 6-1**

## 6.3 Cleaning the Pinch Rollers

1. If the pinch rollers require a thorough cleaning, use a lint-free cloth or cotton swab to wipe away the accumulated dust from the rubber portion of the pinch rollers. To prevent the pinch rollers from rotating while cleaning, use your finger to hold them in place.
2. To remove the deeply-embedded or persistent dust, use the lint-free cloth or cotton swab moistened with rubbing alcohol.

**Note:** Daily maintenance of your cutting plotter is very important. Be sure to clean the grid drum and pinch rollers regularly for better cutting accuracy and output quality.

## Chapter 7 Trouble Shooting

This chapter is to help you correct some common problems you may come across. Prior to getting into the details of this chapter, please be sure that your application environment is compatible with the cutting plotter.

**Note:**

Before having your cutting plotter serviced, please make certain that the malfunction is in your cutting plotter, not the result of an interface problem, a malfunction with your computer, or a software problem.



***Why is the cutting plotter not functioning?***

### ***Possible Causes:***

#### **7.1 Non-Operational Problems**

Check the following first:

- Does the AC power cord plug in properly?
- Does the AC power cord connect to the power connector properly?
- Does the power LED still illuminate?

#### **Solutions:**

If the LCM is able to display the message, the cutting plotter should be operational. Switch off the cutting plotter and turn it on again to see if the problem still persists.

If the LCM is able displaying any message, contact your dealer's service department.

## 7.2 Operational Problems

Some mechanical problems or failure during operation will result in an error message. When you get an error message, please follow the recommended actions. If the problem still exists after the recommended actions have been attempted, have your cutting plotter serviced.

**Error, Check Media  
Or Drum or X Motor**

This message indicates that there might be a problem on the **X axis**. Check if the drum is working well and if the media is properly loaded. Correct the problem and re-power on to reboot system.

**Error, Check Media  
Or Y Motor**

This message indicates that there might be an obstruction to carriage relating to a problem on the **Y axis**. Correct the problem and re-power on to reboot system.

**Error, Check Carriage  
Sensor or VC Motor**

This message indicates that there is a blade up/down sensor malfunction. Re-power on to reboot system. If the problem still persists, contact your dealer.

**Graph Was Clipped.  
Data In Buffer**

This message indicates that the design exceeds the cutting limit. Reload larger media or re-scale the design to a smaller size; then press the key followed by the display of LCM to continue.

## 7.3 Cutting Plotter/Computer Communication Problems

The messages showed below present problems in relation to cutting plotter/computer communication.

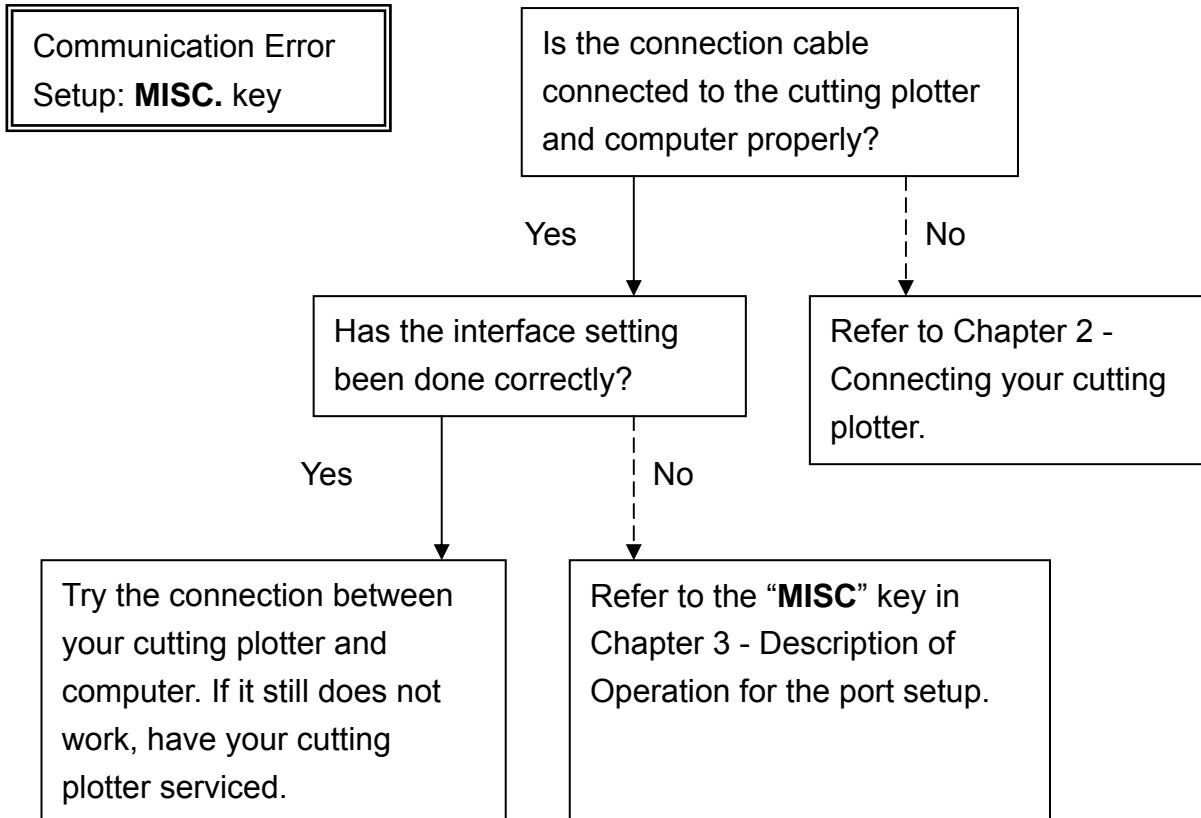

**Note:**  
The computer also needs to set up communication parameters that are compatible with the cutting plotter set up.

HP-GL/2 Cmd. Error

If your cutting plotter cannot recognize the HP-GL/2 or HP-GL commands, please check that the HP-GL/2 or HP-GL commands applied to your cutting plotter are used properly.

## 7.4 Software Problems



**Check the following first:**

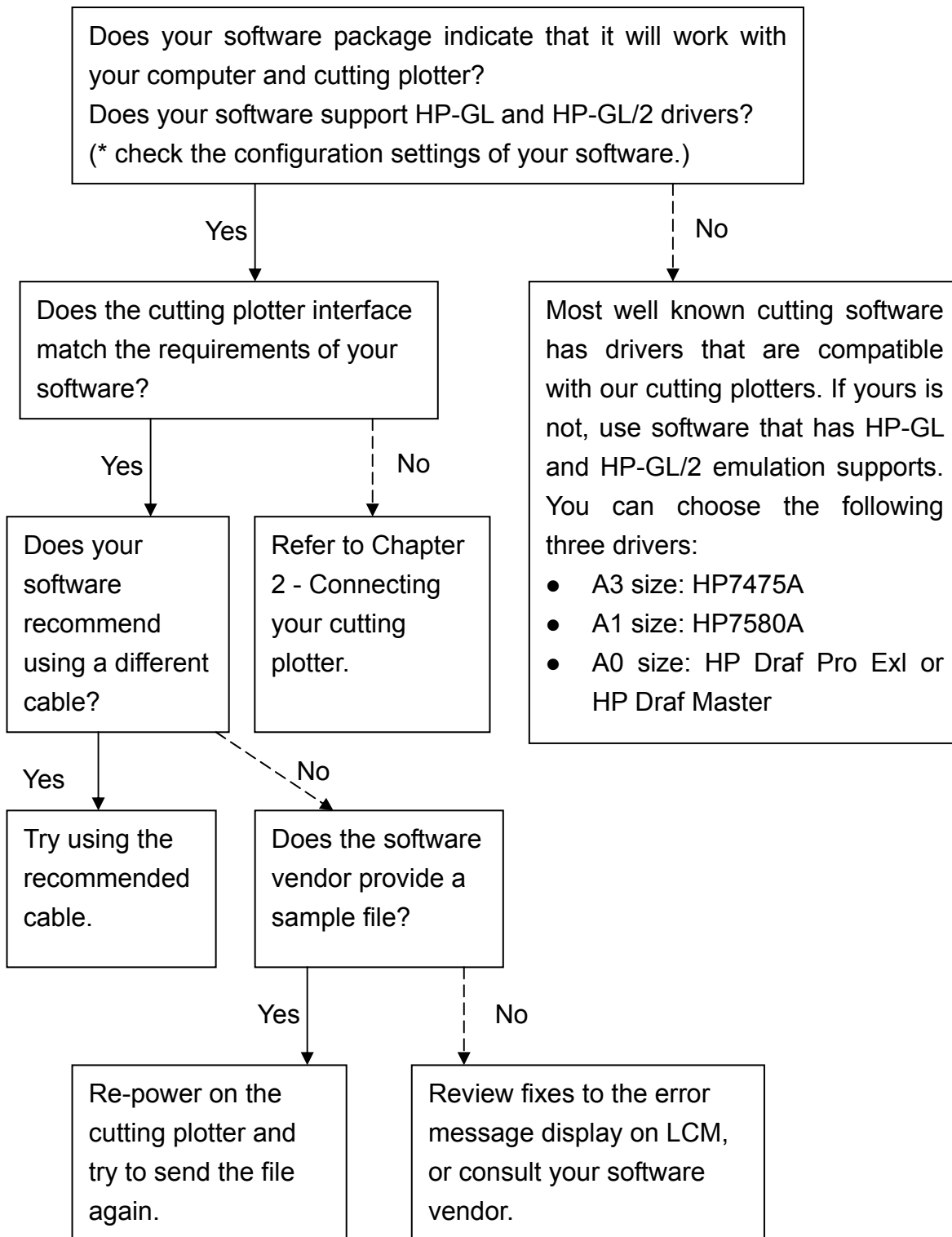

**7.5 Cutting Quality Problems**

**Note:** Daily maintenance of your cutting plotter is very important. Be sure to clean the grid drum and pinch rollers regularly for better cutting accuracy and output quality.

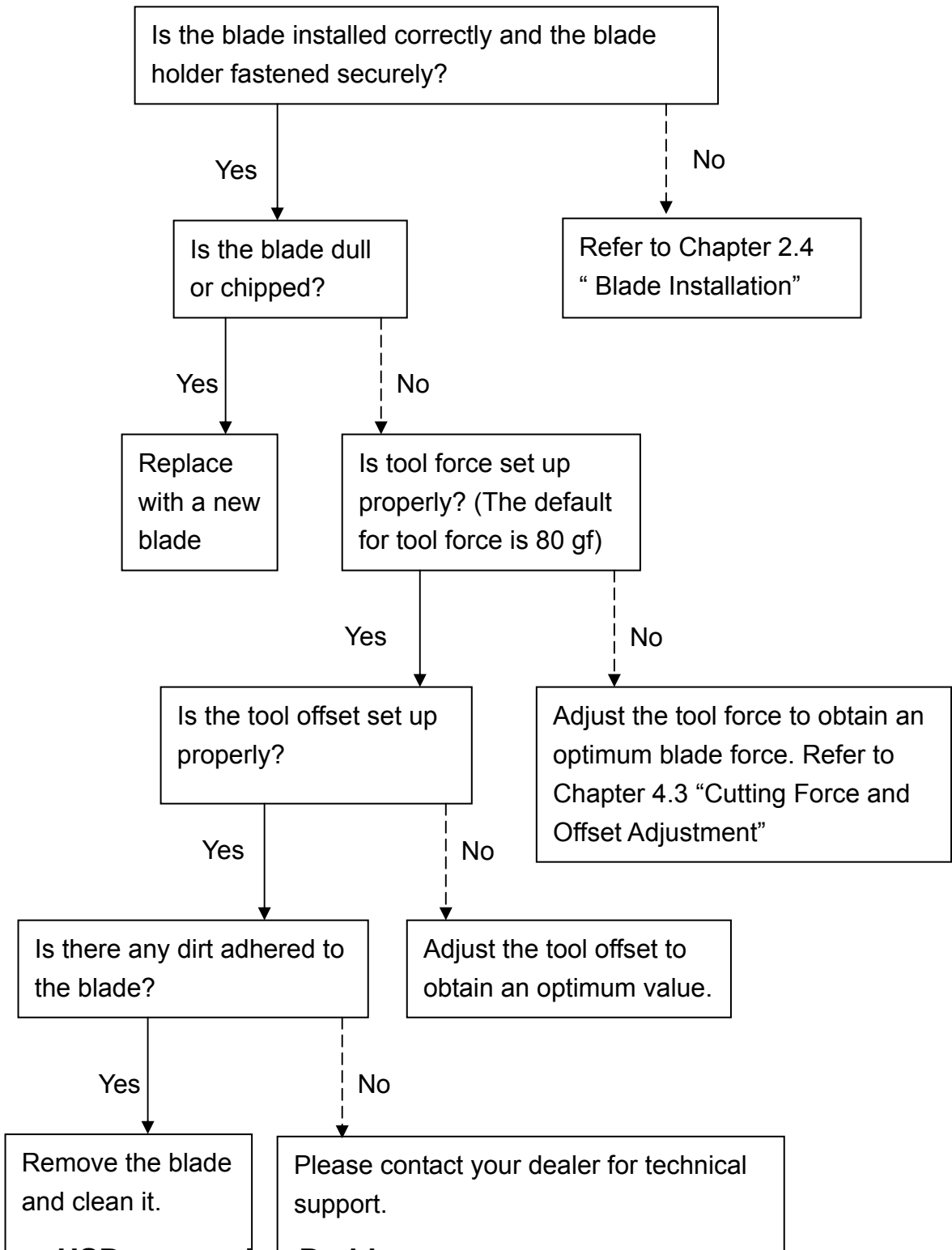

**7.6 USB connection Problems**

**Symptom:**

1. Some customers report that the USB cannot be detected by computer when the USB cable is connected and the plotter is turned on.
2. The USB port can only accept the original port that USB driver was installed. If user connects USB on other USB port, then the computer cannot recognize it or will ask to install driver again.

**Solution:**

Make sure that you have installed the latest ZENCUT BLACK USB driver. After installation, the computer can detect USB connected when plotter is on and the USB cable is connected to computer.

When the USB driver is installed on one USB port and then the USB cable is re-connected to another USB port on the same PC next time, most computers will show the “New Hardware” icon and will ask user if they want to install USB driver again.

(This is the “New Hardware” icon that you may see:)



With some computers (laptops mostly), there is no response when the USB cable is connected, and the “New Hardware” icon cannot be found in the bottom right corner of the screen. Most often, these computers have hardware problems, or the computer has virus and cannot detect some new USB components.

If there is no response when the USB cable is connected, you can follow the below steps to install your ZenCut cutter.

1: Select “Start” → ”Control Panel” → “Add Hardware”

2: Click “Next”.



3. It will take a few moments to detect the USB port.

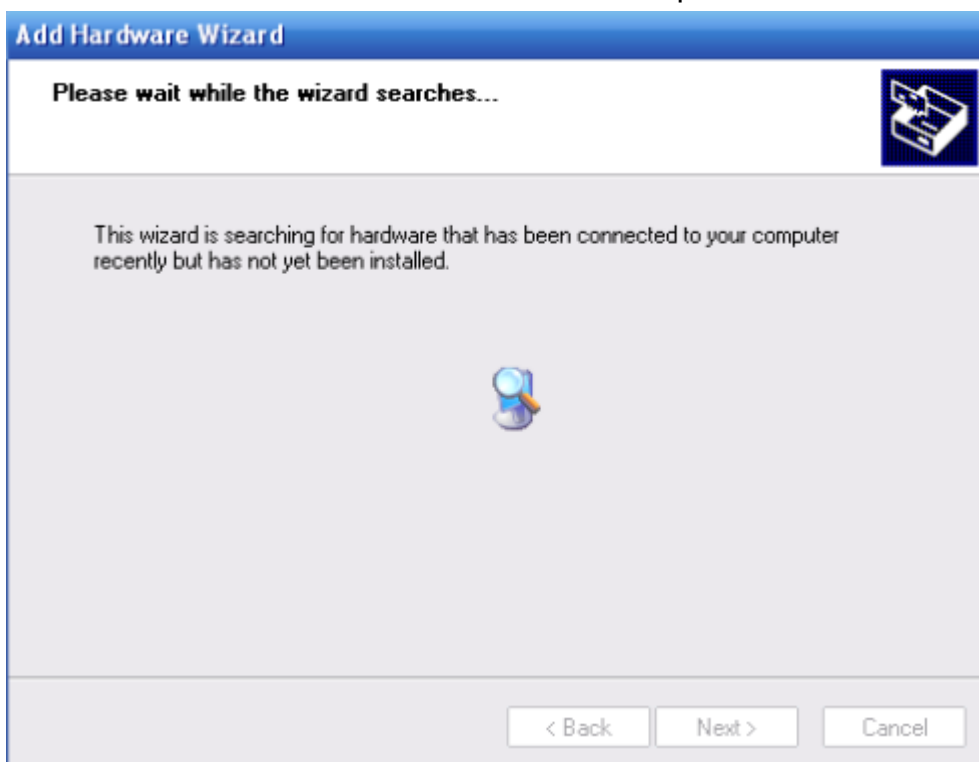

4. Connect ZenCut cutter and select “Yes, I have already connected the hardware.”



5. Select “USB-PRINTER” and click “Next”

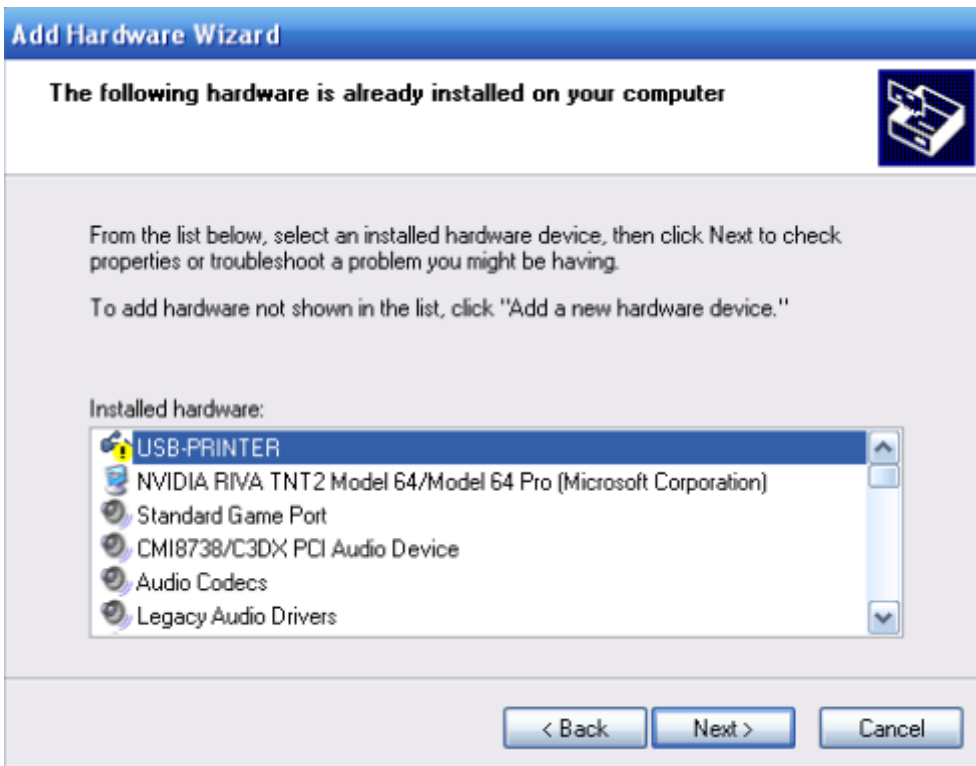

6. Finish



7. Choose "Install the software automatically (Recommended)."



8. Wait a few minutes.

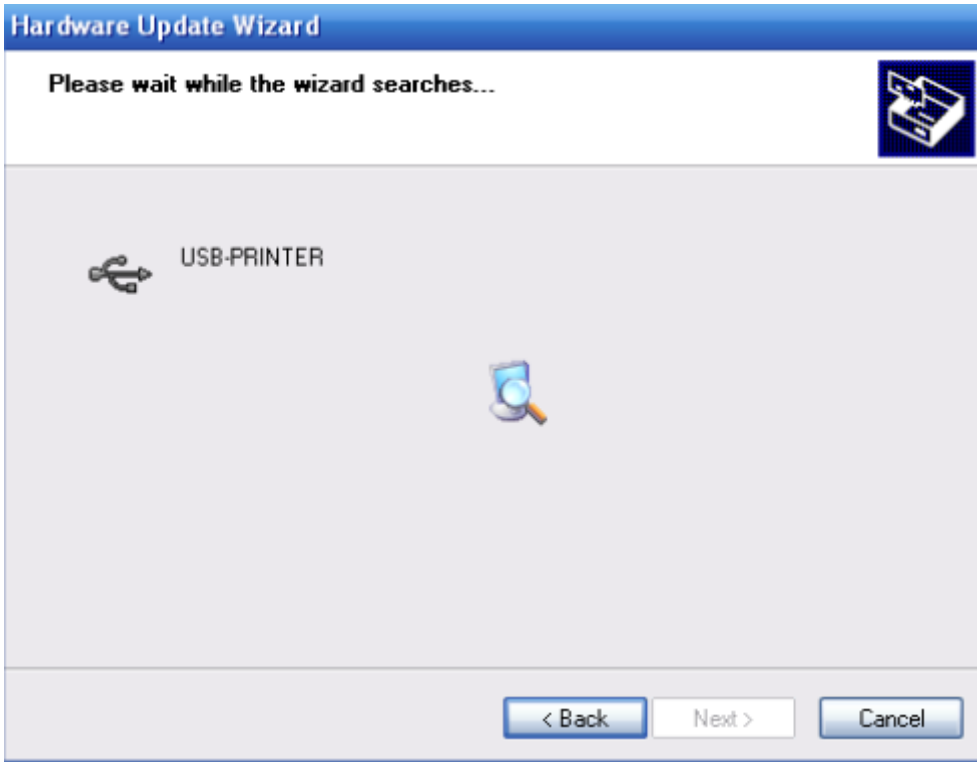

9. Now you can use your ZenCut Black cutter.







## ZenCut Green Specifications

Model Number	ZCB-61	ZCB-101S	ZCB-132S	ZCB-183S
Operational Method	Roller-Type			
Max. Cutting Width	610mm (24in)	1016mm (40in)	1320mm (52in)	1830mm(72in)
Max. Cutting Length	50m (164ft)			
Max. Media Loading Width	770mm (30.3in)	1270mm(50in)	1594mm(62.7in)	1900mm(74.8in)
Min. Media Loading Width	50mm (1.97in)			300mm (11.8in)
Number of Pinch Rollers	3	4	6	
Acceptable Material Thickness	0.8mm (0.03in)			
Drive Motor	DC Servo Control			
Cutting Force	0~600 g			
Max. Cutting Speed	1530 mm/sec (60ips / Diagonal)			
Acceleration	4.2 G (gravity)			
Offset	0~1.0 mm (with an increase of 0.025mm)			
Memory Buffer	4 MB			
Interfaces	USB1.1, Parallel and Serial (RS-232C)			
Type of Command	HP-GL, HP-GL/2			
Mechanical Resolution	0.00625mm			
Software Resolution	0.025 mm			
Repeatability	±0.1mm			
Curve & Arc Smoothing	Yes			
Configurable Origin	Yes			
Test Cut capability	Yes			
Tangential	Yes			
Repeat	Yes			
Copy	Yes			
Pouncing	Yes			
Control Panel	LCD (20 digits x 2 lines), 14 Keys, 1 Power LED			
Power Supply	AC 100-240V, 50~60 Hz (auto switching)			
Power Consumption	Max. 110watts			
Dimension (HxWxD) mm	414 * 930 * 490	1166 * 1430 * 667	1166 * 1754 * 667	750 * 2170 * 1160
(HxWxD) in	16.3 * 36.6 * 19.2	45.9 * 56.0 * 26.3	45.9 * 69.1 * 26.3	29.5 * 85.4 * 45.7
Net Weight	37.2 kg	53.3 kg	61 kg	105 kg
Stand	Optional	Standard		
Accu-Aligning System	Standard AAS-II			
Media Basket	Optional			
Operation	Temperature	10°C~35°C / 50°F~95°F		
Environment	Humidity	25% ~ 75%		

- The specification and data sheet may vary with different materials used. In order to obtain the best output quality, please maintain the machine regularly and properly.
- USCutter reserves the right to change specifications at any time without notice.



# Blade Specifications

26500057G	For cutting thick fluorescent and reflective vinyl. Also for cutting detailed work in standard vinyl.
	The blade is 45° with <b>Red Cap</b> , 0.25 mm offset
	
26500058G	For cutting reflective vinyl, cardboard, sandblast, flock, and stencil sharp edge.
	The blade is 60° with <b>Green Cap</b> , 0.50 mm blade offset
	
26500059G	For cutting thin sandblast mask and stencil with friction feed or sprocket feed machine.
	The blade is 60° with <b>Blue Cap</b> , 0.25 mm blade offset
	
26500060G	For Cutting small text and fine detail. Sharp blade with smallest offset.
	The blade is 0.175 mm blade offset with <b>Black Cap</b>
	

## About the Blade

A generic term referring to the blade that cuts the sheet, the pen that does plotting, and the LED bombsight (option) used for pointing to the reference point.

OFFSET is the distance that the blade tip is displaced from the centerline of the blade.

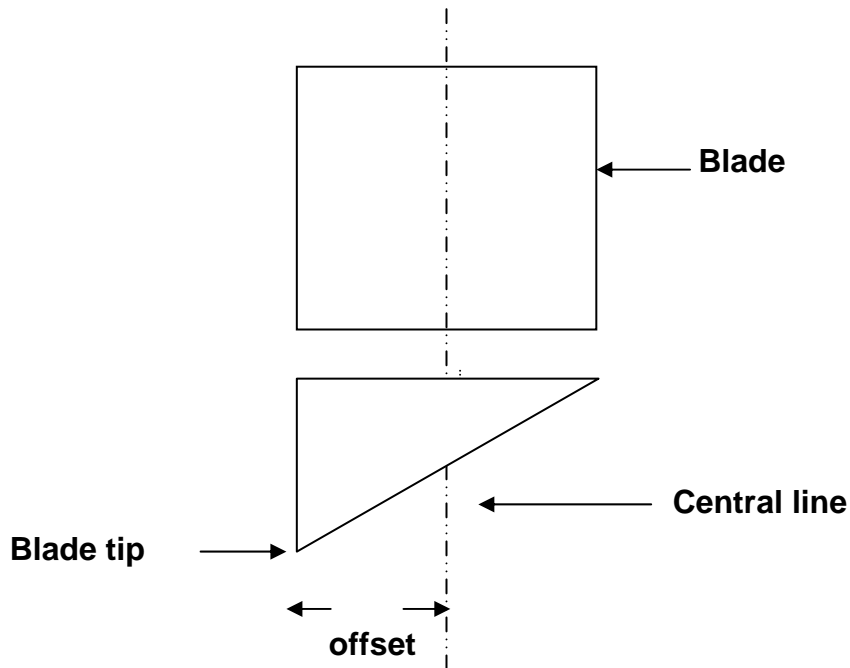

### Protrusion Length of the Blade

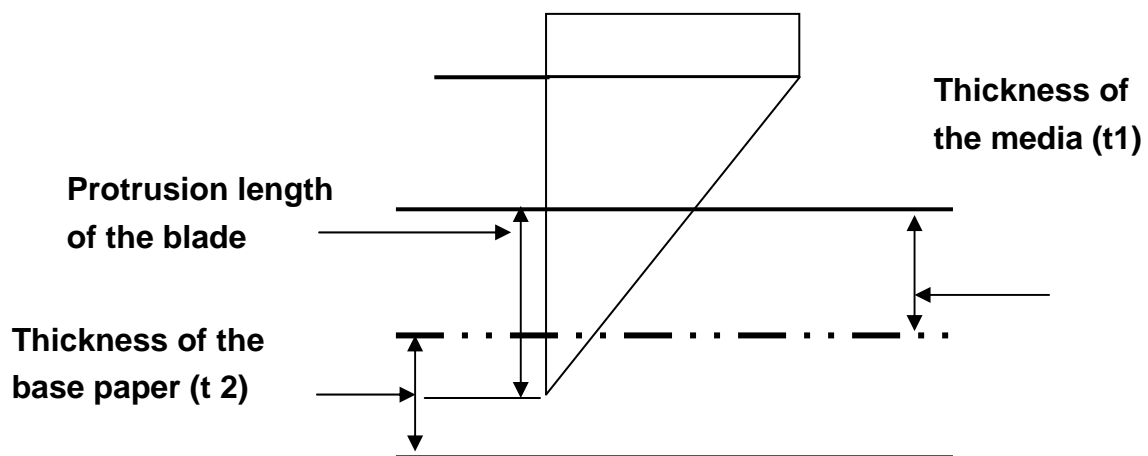

Length of protrusion =  $t_1 + t_2 / 2$ , but for your convenience you may just set it about 0.3mm ~ 0.5mm beyond the blade holder tip.

# CoreIDRAW Plug-In Instruction

AASII VAB Installer is applicable for CoreIDRAW Version 11,12,13,14

## Installation

1. Check the “AAS CoreIDraw Installer” folder in ZenCut Black User CD, and double click the “AASIIInstaller.exe” file to run the installation program.



2. Press “Install” button and start to install ZenCut AASII CoreIDRAW VBA.

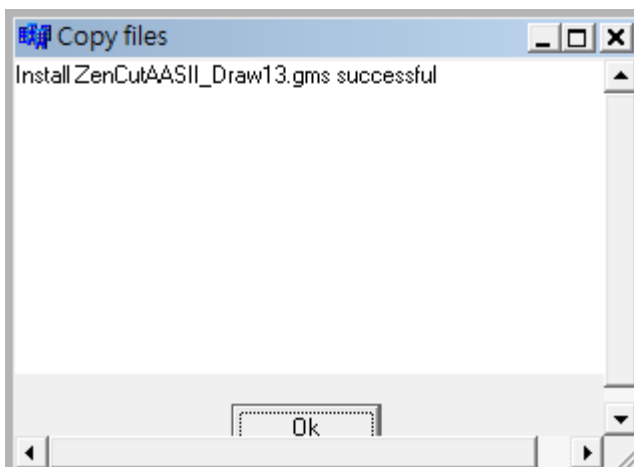
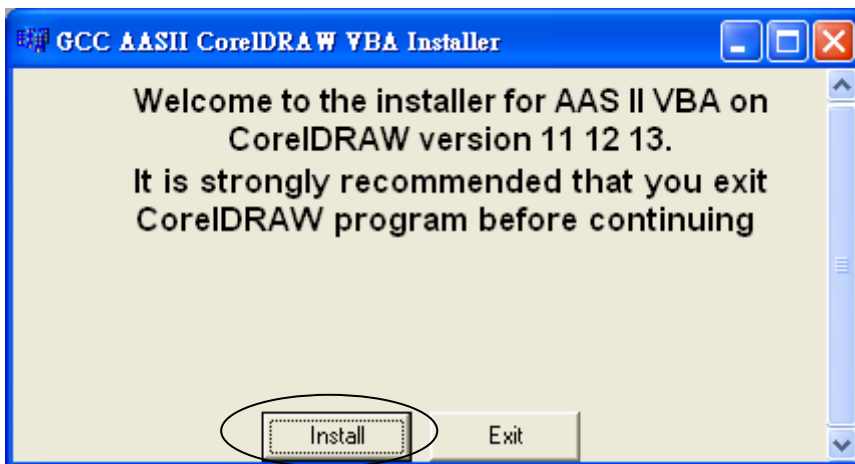

## User Instructions

1. Open CorelDRAW, finish editing all the files you wish to plot and select all the image at once.

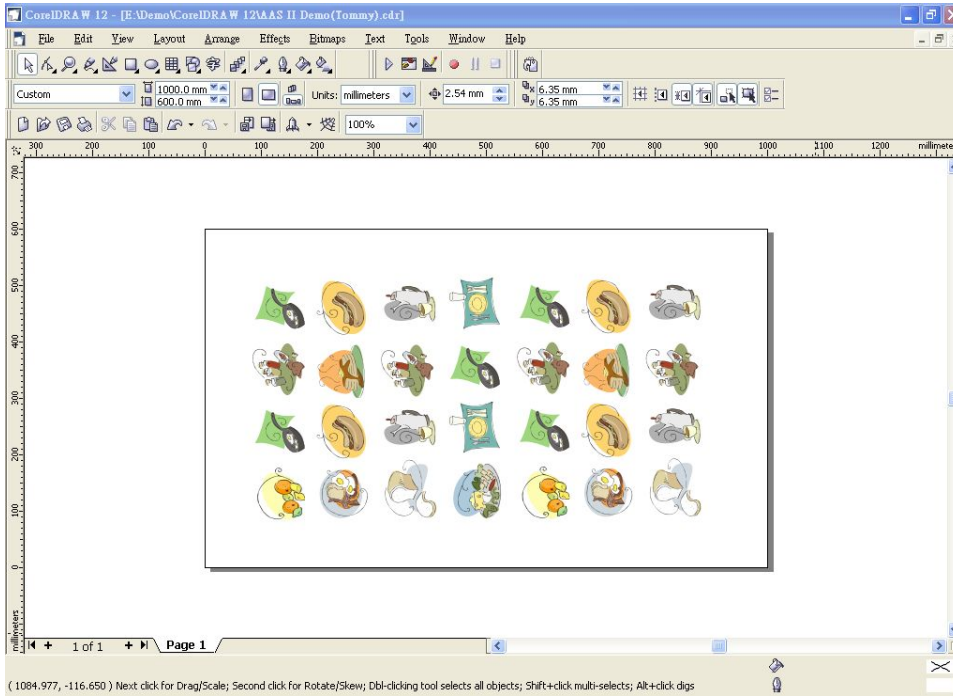

2. Select "Tools→Visual Basic→Play".

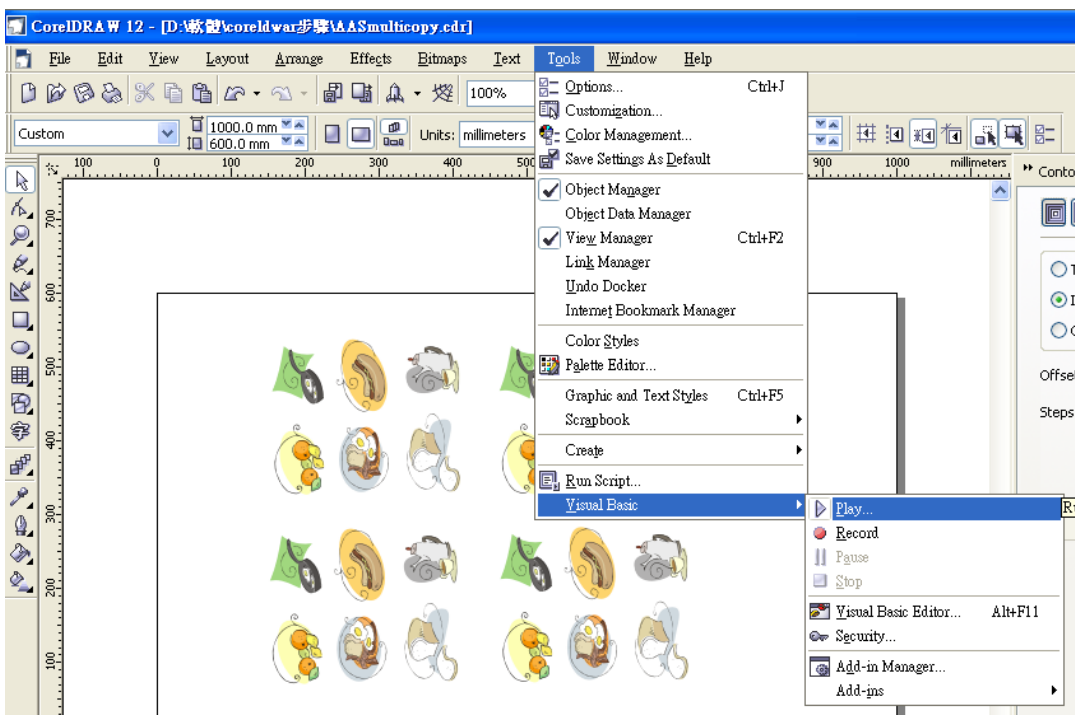

The **Visual Basic for Applications Marcos** window will pop up.

Select **GlobalMacros (ZenCutAASII\_Draw13.gms)** under the “Micros in” manual, and press “Run”.

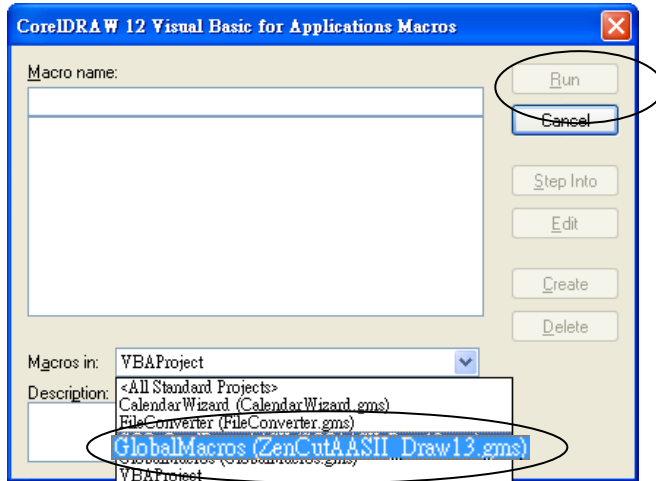

3. Click on “Apply”.

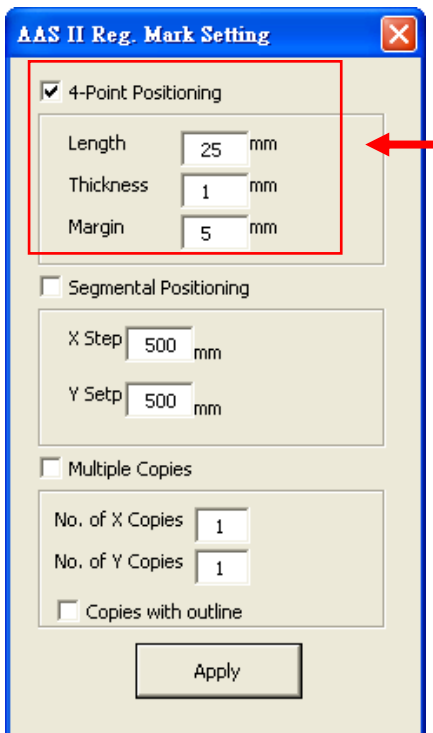

**4-Point Positioning**

- Length: The length of marks  
→ Range: 10mm~50mm  
→ Optimized Setting: 25mm
- Thickness: The line thickness of marks  
→ Range: 1mm~2mm  
→ Optimized Setting: 1mm
- Margin: The distance between marks and images  
→ Range: 1mm~50mm  
→ Optimized Setting: 5mm

**Segmental Positioning**

- X Step: The distance of intermediate position on the X axis
- Y Step: The distance of intermediate position on the Y axis  
→ Range: 200mm~600mm  
→ Optimized Setting: Less than 500mm

**Multiple Copies**

- No. of X Copies: The numbers of copies on X axis
- No. of Y Copies: The numbers of copies on Y axis  
→ Range: 1~50. (The more copies you make, the more time is needed for data transmission.)  
→ Numbers of X Copies \* Numbers of Y Copies = The total amount of image copies

- Copies with outline: To show outlines of image graphics

The system will create the necessary 4 marks on the picture.

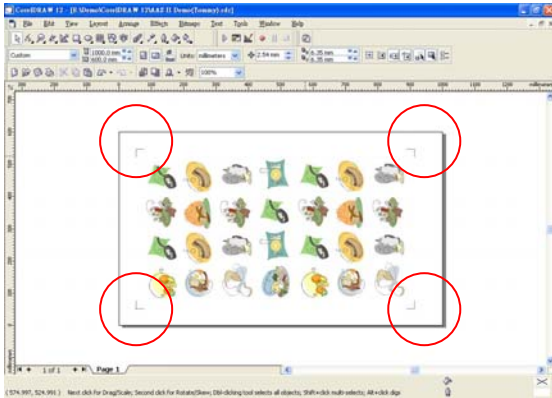

4. Now you can output the image file directly to ZenCut Black to run the AAS function.

**You can also pull out a Hot Icon for the AAS II Plug-in**

Step 1: Select “Tools→Customization→Commands→Macros”.

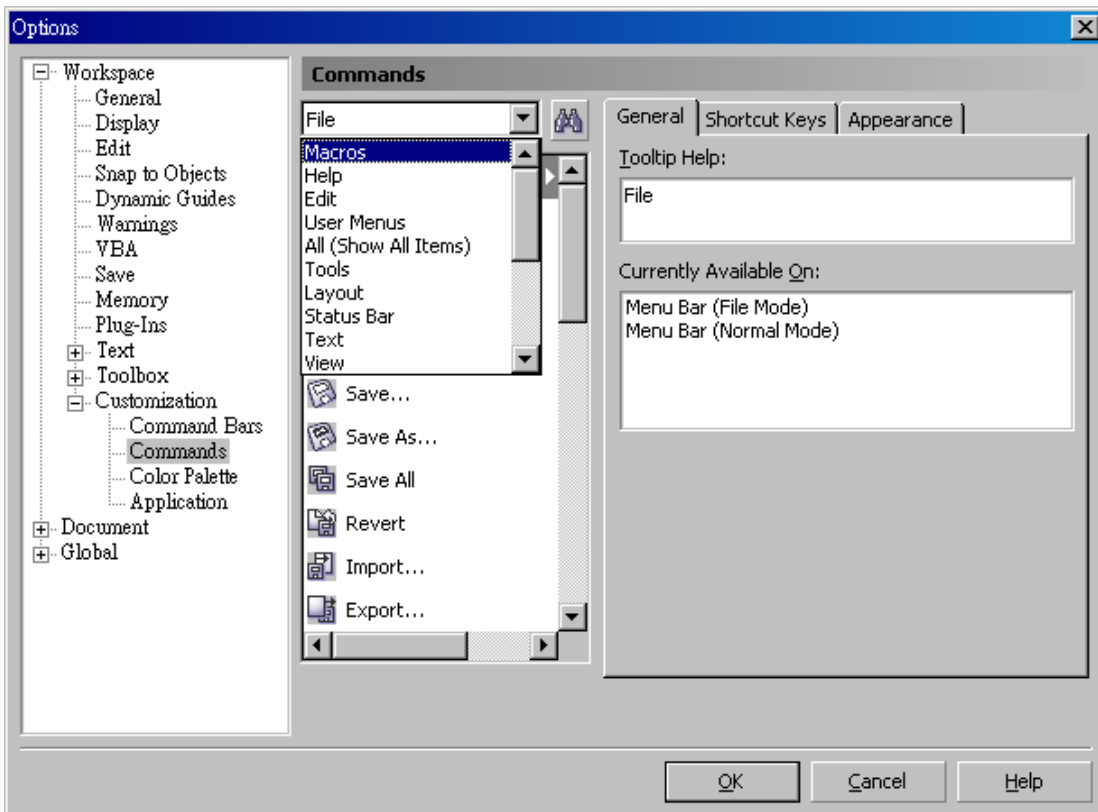

Step 2: Choose **【ZenModule.Zen\_AASII】** and drag it to “commands” bar.

Step 3: If you want to have a different icon, select “Tools→Customization→Commands→Appearance” to import the graphics. Choose an icon and press OK to finish this setting.

