

NXS0003V35A2H1 - NXS0730V35A2L0

NXS0003V35A5H1 - NXS0460V35A5L0

NXS INVERTERS

PRODUCT DATA



- Trip free operation with safety switch
- Silent motor operation with 10 kHz switching frequency
- Over temperature Ride Through
- Power Ride Through
- Integrated PID controller
- Special application software capabilities
- Stand-Alone cabinet design with units higher than 160kW (smaller powers as wall mounted)
- Integrated PFC (Pump & Fan Cascade) –Controller
- The best available fully controlled pump cascade system with special software - Multimaster PFC

SPECIFICATIONS

Mains Connection

Input voltage U_{in} 380...500 Vac (-15 ...+10%) 3~

Input Frequency 45...66 Hz
Connection to mains Once per minute or less

Motor Connection

Output voltage 0... U_{in}

Continuous output current:

Low overload I_L : +40°C, overload 1.1 x I_L
 (for Fan/Pump) (1min/10min)

High overload I_H : +50°C, overload 1.5 x I_H
 (for machines) (1min/10min)

Starting Torque:

Low overload 150%
 (for Fan/Pump)

High overload 200%
 (for machines)

Starting Current $2xI_H$ for 2s/20s

Output Frequency 0...320 Hz; up to 7200 Hz with special software

Frequency resolution 0,01 Hz

GENERAL

These variable frequency drives provide step less speed control for all open loop (no speed feedback from motor) applications in HVAC and industrial environments:

- Pumps
- Fans
- Compressors
- Conveyors
- Lifts
- Escalators
- Mixers

FEATURES

- **Most compact size in the market (especially IP54)**
- **Integrated RFI-filters and AC-chokes**
- **Application adapting Start Up Wizard**
- **Application adapting Quick menu**
- **Flexible "ALL IN ONE" multipurpose software with predefined applications**
- **Alphanumeric keypad with memory and backup functions**
- **Easy "keypad – remote" change with 1 button**

® U.S. Registered Trademark

Copyright © 2011 Honeywell Inc. • All rights reserved



EN0B0620GE51 R0611

Control Characteristics

Control Method Frequency Control U/f
Open Loop Sensorless Vector Control

Switching Frequency:
FR4 – FR6 (1.1-30kW) 1...16 kHz;
NXS0003...- NXS0061... Default: 10 kHz (no derating)

FR7 – FR11 (37-400 kW) 1... 10 kHz
NXS0072...- NXS0730... Default: 3.6 kHz

Frequency reference:
Analogue input Resolution 0.1% (10bit), accuracy $\pm 1\%$

Keypad reference Resolution 0.01 Hz

Field Weakening point 8...320 Hz

Acceleration time 0...3000 sec

Deceleration time 0...3000 sec

Braking torque DC-brake: 30%*TN (without brake option)

Ambient Conditions

Ambient operating Temperature:
Low overload (for Fan/Pump) -10°C (no frost)... $+45^{\circ}\text{C}$ (with 24h average $+40^{\circ}\text{C}$)

Storage temperature -40°C ... $+70^{\circ}\text{C}$

Relative humidity 0...95% RH, non-condensing, non-corrosive, no dripping water

Air quality:
Chemical vapors IEC 721-3-3, unit in operation, class 3C2

Mechanical particles IEC 721-3-3, unit in operation, class 3S2

Altitude 100% load capacity (no derating) up to 1000m
1-% derating for each 100m above 1000m; max. 3000m

Relative humidity 0...95% RH, non-condensing, non-corrosive, no dripping water

Vibration:
EN50178/EN60068-2-6 5...150 Hz
Displacement amplitude 1(peak) mm at 5...15.8 Hz
Max acceleration amplitude 1 G at 15.8...150 Hz

Shock:
EN50178, IEC 68-2-27 UPS Drop Test (for applicable UPS weights)
Storage and shipping: max 15 G, 11 ms (in package)

Enclosure class IP21 : NXS___ V35A2...
IP54 : NXS___ V35A5...

Enclosure type

Standard in 1,1-160 kW Wall mounted IP21 and IP54
NXS0003...- NXS0310...

Standard in 200-400 kW Stand-Alone cabinet design
NXS0385...- NXS0730... IP21 and IP54 (up to 250 kW)

Electro Magnetic Compatibility (EMC)

Immunity EN61800-3 (both industrial and public electrical network requirements fulfilled as standard)

Emissions:
Standard in 1.1-160 kW EMC-level H: EN 61800-3
NXS0003...- NXS0310... (2004) Category C2

Standard in 200-400 kW EMC-level L: EN 61800-3
NXS0385...- NXS0730... (2004) Category C3

Safety

EN60204-1, CE, EN61800-5
(see unit nameplate for more detailed approvals)

Control connections

Analogue input voltage 0...+10V, Ri = 200k Ω , Resolution 10 bit, accuracy $\pm 1\%$

Analogue input current 0(4)...20 mA, Ri = 250 Ω differential resolution 0.1%, accuracy $\pm 1\%$

Digital inputs 6 positive logic; 18...24VDC

Auxiliary voltage +24V, $\pm 15\%$, max. 100mA

Output reference voltage +10V, +3%, max. load 10mA

Analogue output 0(4)...20mA; RL max. 500 Ω ; resolution 16 bit; accuracy $\pm 1\%$

Relay outputs 2 programmable change over relay output (1 NO/NC and 1 NO). Switching capacity: 24VDC/8A, 250VAC/8A, 125VDC/0.4A. Min.switching load: 5 V/10 mA

Digital output	Open collector output 50 mA/48 V	Motor overload protection	YES
Motor thermistor Input	Rtrip = 4.7 kΩ (PTC) Galvanically isolated	Motor stall protection <i>(fan/pump blocked)</i>	YES
		Motor underload protection <i>(pump dry / belt broken detection)</i>	YES
Protections		Short-circuit protection of +24V and +10V reference voltages	YES
Overvoltage protection	911VDC		
Undervoltage protection	333VDC		
Earth-fault protection	In case of earth fault in motor or motor cable, only the inverter is protected		
Input phase supervision	YES		
Motor phase supervision	YES		
Overcurrent protection	Trip limit $4,0 \cdot I_H$ instantaneously		
Unit overtemperature protection	YES		

PRODUCT IDENTIFICATION CODE

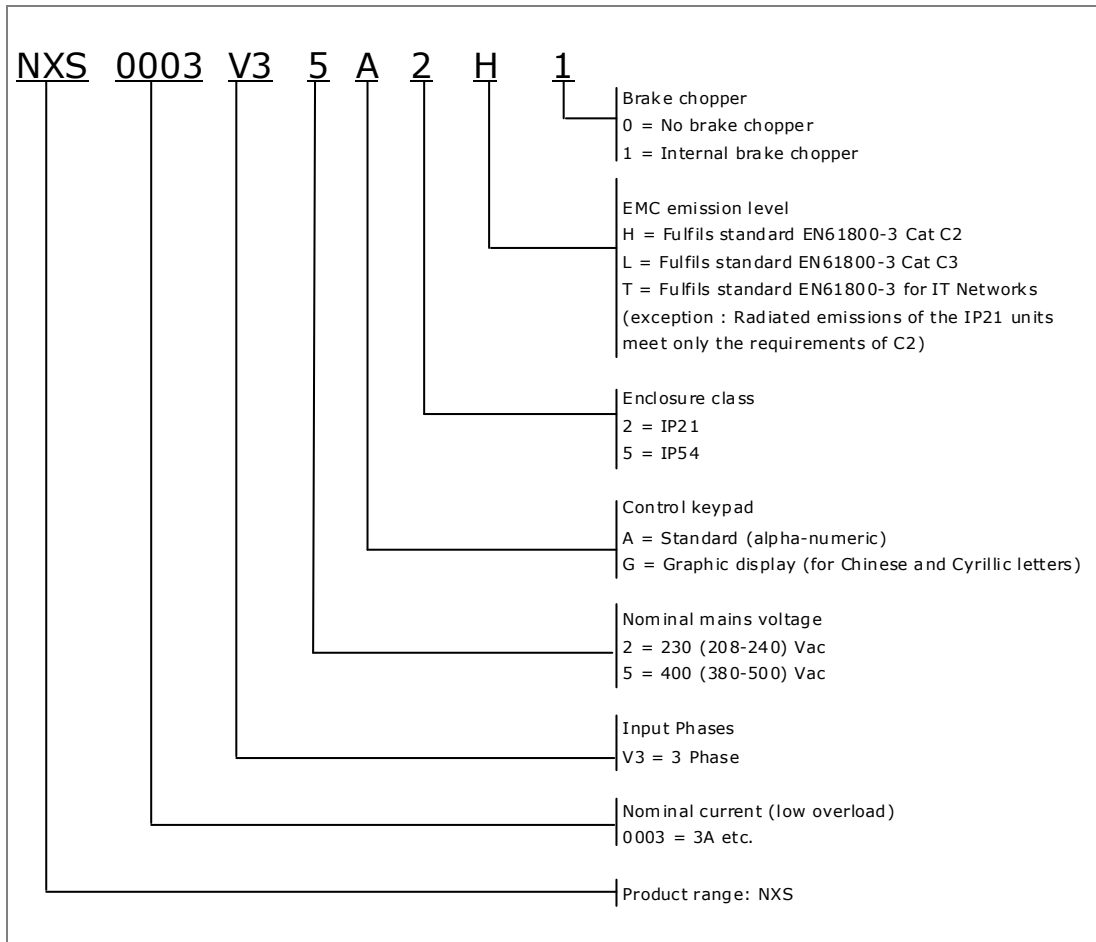

Fig. 1. Product Identification Code

MODELS IN STANDARD SELECTION

Mains voltage 3~ 380-500 V, 50/60 Hz, Series NXS									
Product type	Motor shaft power		Loadability				Mechanical size enclosure / protection class	Dimensions WxHxD [mm]	Weight [kg]
	400V supply		Low		High				
	Low overload (for Pump / Fan) 40°C P [kW]	High overload (for Machines) 50°C P [kW]	Rated continuous current I _L [A]	10% overload current [A]	Rated continuous current I _H [A]	50% overload current [A]			
NXS0003V35A2H1	1,1	0,75	3,3	3,6	2,2	3,3	FR4/IP21	128x292x190	5
NXS0004V35A2H1	1,5	1,1	4,3	4,7	3,3	5,0	FR4/IP21	128x292x190	5
NXS0005V35A2H1	2,2	1,5	5,6	6,2	4,3	6,5	FR4/IP21	128x292x190	5
NXS0007V35A2H1	3	2,2	7,6	8,4	5,6	8,4	FR4/IP21	128x292x190	5
NXS0009V35A2H1	4	3	9	9,9	7,6	11,4	FR4/IP21	128x292x190	5
NXS0012V35A2H1	5,5	4	12	13,2	9	13,5	FR4/IP21	128x292x190	5
NXS0016V35A2H1	7,5	5,5	16	17,6	12	18	FR5/IP21	144x391x214	8,1
NXS0022V35A2H1	11	7,5	23	25,3	16	24	FR5/IP21	144x391x214	8,1
NXS0031V35A2H1	15	11	31	34	23	35	FR5/IP21	144x391x214	8,1
NXS0038V35A2H1	18,5	15	38	42	31	47	FR6/IP21	195x519x237	18,5
NXS0045V35A2H1	22	18,5	46	51	38	57	FR6/IP21	195x519x237	18,5
NXS0061V35A2H1	30	22	61	67	46	69	FR6/IP21	195x519x237	18,5
NXS0072V35A2H0	37	30	72	79	61	92	FR7/IP21	237x591x257	35
NXS0087V35A2H0	45	37	87	96	72	108	FR7/IP21	237x591x257	35
NXS0105V35A2H0	55	45	105	116	87	131	FR7/IP21	237x591x257	35
NXS0140V35A2H0	75	55	140	154	105	158	FR8/IP21	291x758x344	58
NXS0168V35A2H0	90	75	170	187	140	210	FR8/IP21	291x758x344	58
NXS0205V35A2H0	110	90	205	226	170	255	FR8/IP21	291x758x344	58
NXS0260V35A2H0	132	110	261	287	205	308	FR9/IP21	480x1150x362	146
NXS0310V35A2H0	160	132	300	330	245	368	FR9/IP21	480x1150x362	146
NXS0385V35A2L0	200	160	385	424	300	450	FR10/IP21	595x2018x602	270
NXS0460V35A2L0	250	200	460	506	385	578	FR10/IP21	595x2018x602	270
NXS0590V35A2L0	315	250	590	649	520	780	FR11/IP21	794x2018x602	470
NXS0650V35A2L0	355	315	650	715	590	885	FR11/IP21	794x2018x602	470
NXS0730V35A2L0	400	355	730	803	650	975	FR11/IP21	794x2018x602	470

NXS0003V35A5H1	1,1	0,75	3,3	3,6	2,2	3,3	FR4/IP54	128x292x190	5
NXS0004V35A5H1	1,5	1,1	4,3	4,7	3,3	5,0	FR4/IP54	128x292x190	5
NXS0005V35A5H1	2,2	1,5	5,6	6,2	4,3	6,5	FR4/IP54	128x292x190	5
NXS0007V35A5H1	3	2,2	7,6	8,4	5,6	8,4	FR4/IP54	128x292x190	5
NXS0009V35A5H1	4	3	9	9,9	7,6	11,4	FR4/IP54	128x292x190	5
NXS0012V35A5H1	5,5	4	12	13,2	9	13,5	FR4/IP54	128x292x190	5
NXS0016V35A5H1	7,5	5,5	16	17,6	12	18	FR5/IP54	144x391x214	8,1
NXS0022V35A5H1	11	7,5	23	25,3	16	24	FR5/IP54	144x391x214	8,1
NXS0031V35A5H1	15	11	31	34	23	35	FR5/IP54	144x391x214	8,1
NXS0038V35A5H1	18,5	15	38	42	31	47	FR6/IP54	195x519x237	18,5
NXS0045V35A5H1	22	18,5	46	51	38	57	FR6/IP54	195x519x237	18,5
NXS0061V35A5H1	30	22	61	67	46	69	FR6/IP54	195x519x237	18,5
NXS0072V35A5H0	37	30	72	79	61	92	FR7/IP54	237x591x257	35
NXS0087V35A5H0	45	37	87	96	72	108	FR7/IP54	237x591x257	35
NXS0105V35A5H0	55	45	105	116	87	131	FR7/IP54	237x591x257	35
NXS0140V35A5H0	75	55	140	154	105	158	FR8/IP54	291x758x344	58
NXS0168V35A5H0	90	75	170	187	140	210	FR8/IP54	291x758x344	58
NXS0205V35A5H0	110	90	205	226	170	255	FR8/IP54	291x758x344	58
NXS0260V35A5H0	132	110	261	287	205	308	FR9/IP54	480x1150x362	146
NXS0310V35A5H0	160	132	300	330	245	368	FR9/IP54	480x1150x362	146
NXS0385V35A5L0	200	160	385	424	300	450	FR10/IP54	595x2018x602	270
NXS0460V35A5L0	250	200	460	506	385	578	FR10/IP54	595x2018x602	270

HONEYWELL EMC CLASSES AND MARKET REQUIREMENTS

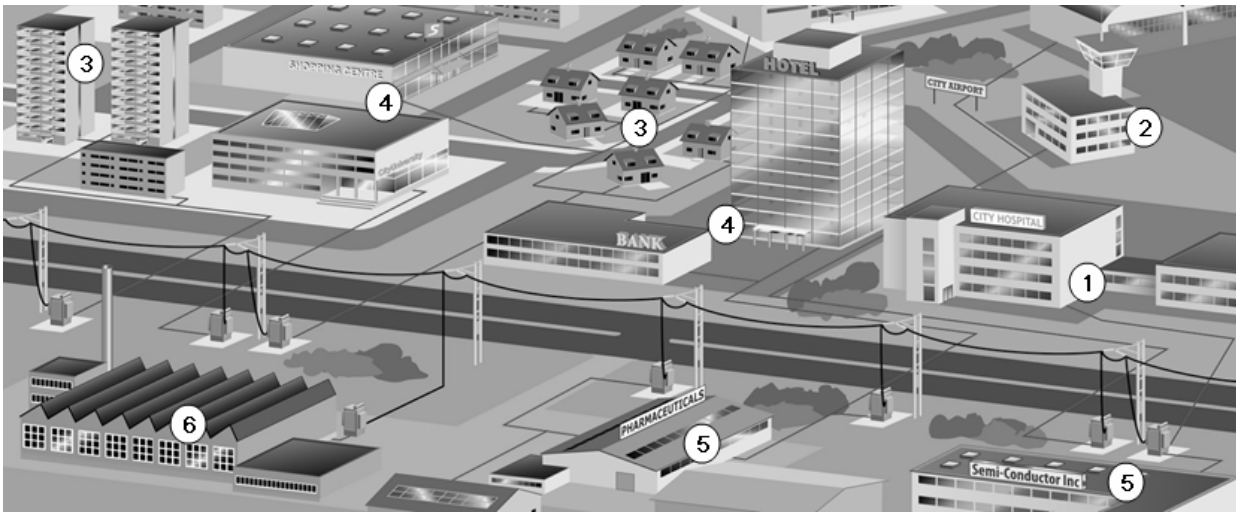

Fig. 2. EMC classes in practice



EMC levels	Hospital	Airport	Residential Area	Commercial	Light Industry Area	Heavy Industry
C	O	O				
H	R	R	R	R	O	O
L					R	R
T						R (IT Network)

O = Optional, R= Required

C = EN61800-3 [2004] Category C1 (only available with NXL HVAC inverter family)

H = EN61800-3 [2004] Category C2 (standard in NXS up to 160 kW)

L = EN61800-3 [2004] Category C3 (NXS units in 200 - 400 kW)

T = EN61800-3 [2004] IT network (e.g. ships) requirements fulfilled, size FR4-FR8 inverters (NXS0003-NXS0205) can be easily converted to T-class from standard EMC class. Instructions for this can be found from NX Series User's Manual included in all NXS deliveries or downloaded from <http://inverter.ecc.emea.honeywell.com>

MECHANICAL DIMENSIONS AND MOUNTING

The inverter can be mounted in either vertical or horizontal position on the wall or on the back plane of a cubicle. It shall be fixed with four screws (or bolts, depending on the unit size). Lift units bigger than FR7 out of the package using a jib crane.

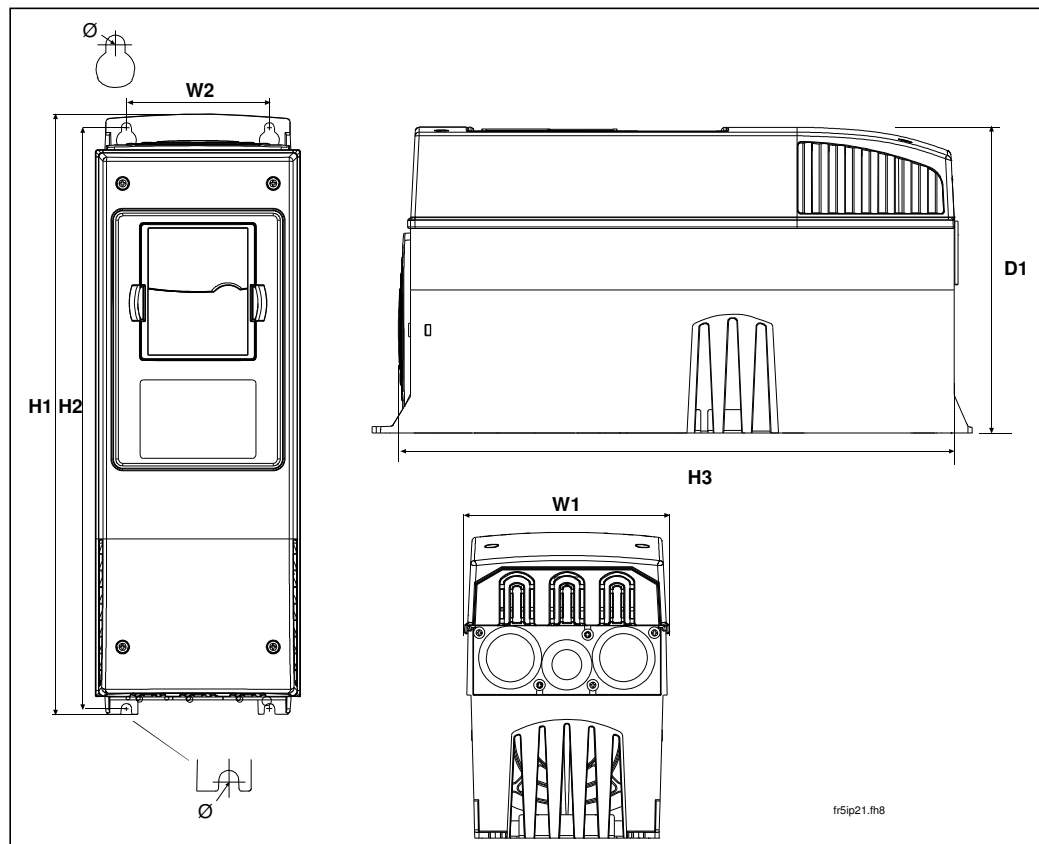

Fig. 3. NXS FR4 – FR8 (NXS0003... - NXS0205...) dimensions

Type	Dimensions [mm]								
	W1	W2	H1	H2	H3	D1	Ø	E1Ø	E2Ø*
NXS0003—NXS0012	128	100	327	313	292	190	7	3 x 28,3	
NXS0016—NXS0031	144	100	419	406	391	214	7	2 x 37	1 x 28,3
NXS0038—NXS0061	195	148	558	541	519	237	9	3 x 37	
NXS0072—NXS0105	237	190	630	614	591	257	9	3 x 47	
NXS0140—NXS0205	285	255	755	732	721	312	9	3 x 59	

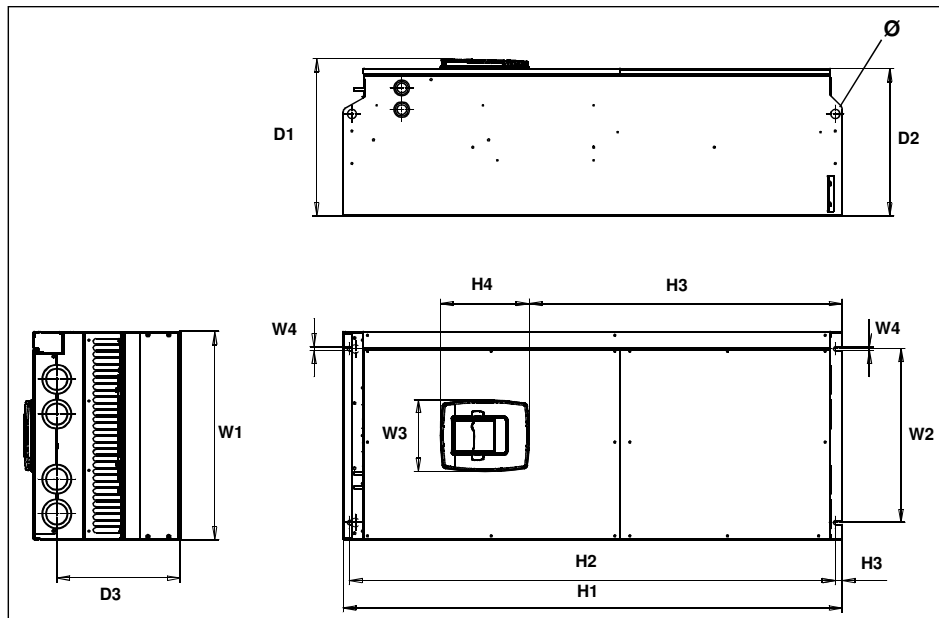

Fig. 4. NXS FR9 (NXS0260... - NXS0310...) dimensions

Type	Dimensions [mm]											
	W1	W2	W3	W4	H1	H2	H3	H4	D1	D2	D3	Ø
NXS0260—NXS0310	480	400	165	9	1150	1120	721	205	362	340	285	21

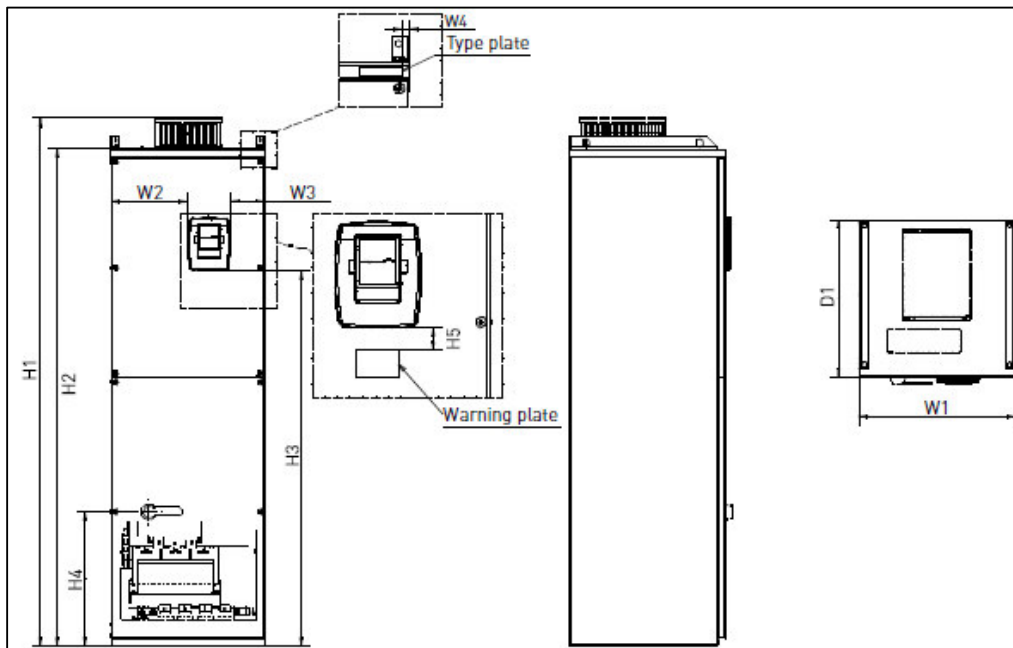
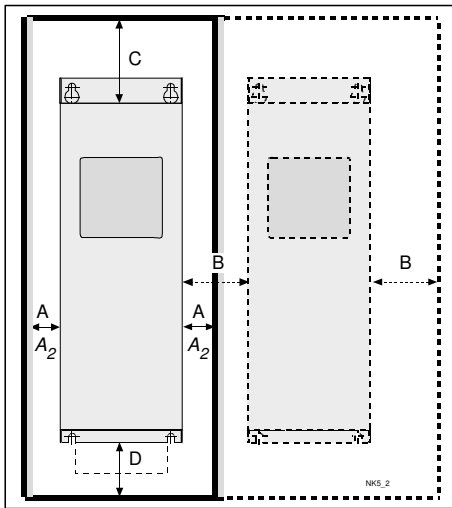

Fig. 5. NXS FR10 -11 (NXS0385... - NXS0730...) dimensions (floorstanding units)

Type	Dimensions [mm]									
	W1	W2	W3	W4	H1	H2	H3	H4	D1	
NXS0385—NXS0460	595	291	131	15	2018	1900	1435	512	602	
NXS0590—NXS0730	794	390	230	15	2018	1900	1435	512	602	

Enough free space shall be left above and below the inverter to ensure sufficient air circulation and cooling. You will find the required dimensions for free space in the table below.



Type	Dimensions				
	A	A ₂	B	C	D
NXS0003—NXS0012	20		20	100	50
NXS0016—NXS0031	20		20	120	60
NXS0038—NXS0061	30		20	160	80
NXS0072—NXS0105	80		80	300	100
NXS0140—NXS0205	80	150	80	300	200
NXS0260—NXS0310	50		80	400	250 (350*)

- A** = clearance around the inverter (see also A₂ and B)
- A₂** = clearance needed on either side of the inverter for fan change (without disconnecting the motor cables)
- B** = distance from one inverter to another or distance to cabinet wall
- C** = free space above the inverter
- D** = free space underneath the inverter
- * = min. clearance for fan change

Fig. 6. NXS FR4 – FR9 (NXS0003... - NXS0310...) installation space

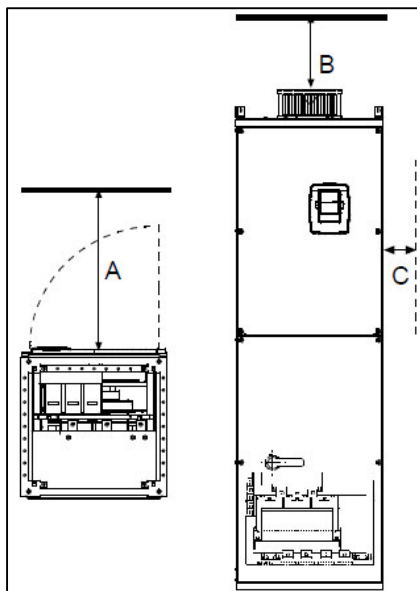

Type	Dimensions		
	A	B	C
NXS0385—NXS0730	800	200	20

- A** = clearance in front of the inverter
- B** = free space above the inverter
- C** = distance from one inverter to another or distance to wall

Fig. 7. NXS FR10 – FR11 (NXS0385... - NXS0730...) installation space

REQUIRED COOLING AIR

Type	Cooling air required [m ³ /h]
FR4: NXS0003—NXS0012	70
FR5: NXS0016—NXS0031	190
FR6: NXS0038—NXS0061	425
FR7: NXS0072—NXS0105	425
FR8: NXS0140—NXS0205	650
FR9: NXS0260—NXS0310	1300
FR10: NXS0385—NXS0460	2600
FR11: NXS0590—NXS0730	3900

CABLING

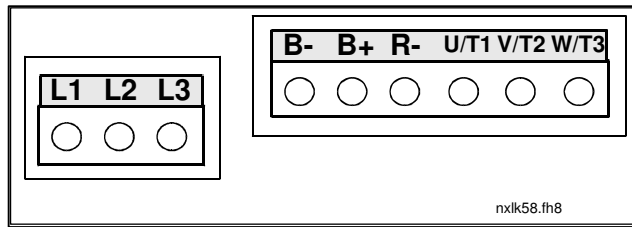

Fig. 8. NXS power connections FR4-FR6 in FR7-FR11 connectors B-, B+ and R- do not exist as standard.

Use cables with heat resistance of at least +70°C. The cables and the fuses must be dimensioned according to the tables below. The fuses function also as cable overload protection. These instructions apply only to cases with one motor and one cable connection from the inverter to the motor. In any other case, ask the technical support for more information.

Connection	Cable type
Mains cable	Power cable intended for fixed installation and the specific mains voltage. Shielded cable not required. (NKCABLES/MCMK or similar recommended)
Motor cable	Power cable equipped with compact low-impedance shield and intended for the specific mains voltage. (NKCABLES/MCCMK, SAB/ÖZCUY-J or similar recommended). (360° earthing of both motor and FC connection required to meet the EMC requirements)
Control cable	Screened cable equipped with compact low-impedance shield (NKCABLES /jamak, SAB/ÖZCuY-O or similar)

Frame	Type	I _L [A]	Fuse [A]	Mains and motor cable Cu [mm ²]	Terminal cable size	
					Main terminal [mm ²]	Earth terminal [mm ²]
FR4	NXS0003—NXS0009	3—9	10	3*1.5+1.5	1—4	1—2.5
	NXS0012	12	16	3*2.5+2.5	1—4	1—2.5
FR5	NXS0016	16	20	3*4+4	1—10	1—10
	NXS0022	22	25	3*6+6	1—10	1—10
	NXS0031	31	35	3*10+10	1—10	1—10
FR6	NXS0038—NXS0045	38—45	50	3*10+10	2.5—50 Cu 6—50 Al	6—35
	NXS0061	61	63	3*16+16	2.5—50 Cu 6—50 Al	6—35
FR7	NXS0072	72	80	3*25+16	2.5—50 Cu 6—50 Al	6—70
	NXS0087	87	100	3*35+16	2.5—50 Cu 6—50 Al	6—70
	NXS0105	105	125	3*50+25	2.5—50 Cu 6—50 Al	6—70
FR8	NXS0140	140	160	3*70+35	25—95 Cu/Al	25—95
	NXS0168	168	200	3*95+50	95—185 Cu/Al	25—95
	NXS0205	205	250	3*150+70	95—185 Cu/Al	25—95
FR9	NXS0260	261	315	3*185+95 or 2*(3*120+70)	95—185 Cu/Al 2	5—95
	NXS0310	300	315	2*(3*120+70)	95—185 Cu/Al 2	5—95
FR10	NXS0385	385	400	2*(3*120+70)		
	NXS0460	460	500	2*(3*150+70)		
FR11	NXS0590	590	630	2*(3*240+120)		
	NXS0650	650	800	4*(3*95+50)		
	NXS0730	730	800	4*(3*120+70)		

1	+10 V _{ref}	Reference output (voltage for potentiometer etc.)
2	AI1 +	Analogue Input 1 (V signal)
3	AI1 -	I/O ground
4	AI2 +	Analogue Input 2 (mA signal)
5	AI2 -	
6	+24 V	+24 V input/output (max. 0.1 A)
7	GND	I/O ground
8	DIN1	Digital Input 1
9	DIN2	Digital Input 2
10	DIN3	Digital Input 3

11	CMA	Digital input common for DIN1, DIN2 and DIN3
12	+24 V	Same as terminal 6
13	GND	I/O ground
14	DIN4	Digital Input 4
15	DIN5	Digital Input 5
16	DIN6	Digital Input 6
17	CMB	Digital input common for DIN4, DIN5 and DIN6
18	AO1 +	Analogue output 1, default range: 0–20 mA/R _L , max. 500 Ω
19	AO1 -	
20	DO1	Open collector Output

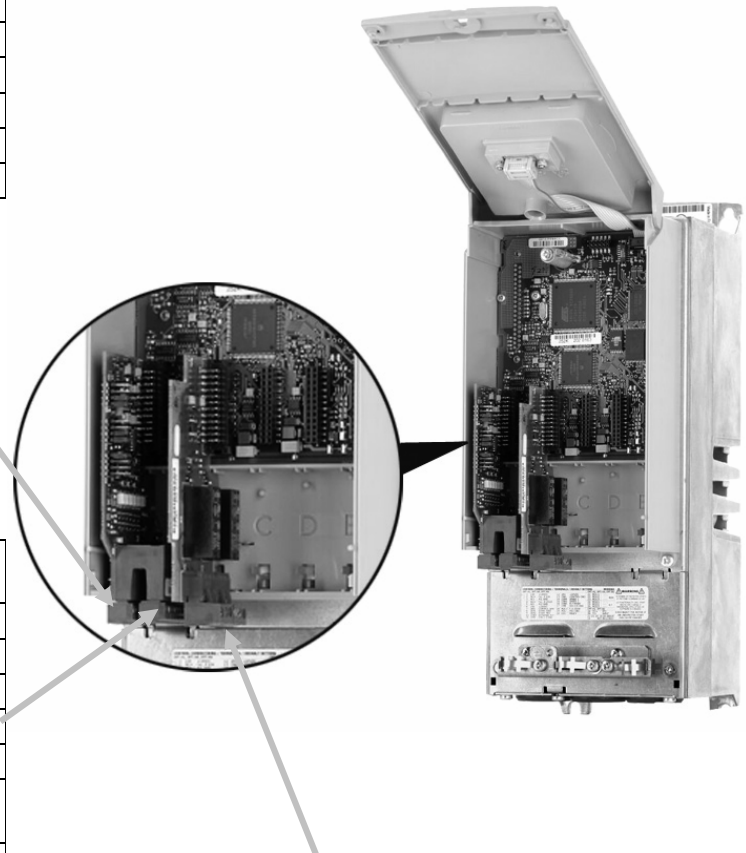

21	RO1		Relay 1 NO/NC
22	RO1		
23	RO1		
25	RO2		Relay 2 NO
26	RO2		
28	TI+	Thermistor Input; R _{trip} = 4.7 kΩ (PTC)	
29	TI-		

Fig. 9. NXS control connections

FEATURES / FUNCTIONS

- **Easy to set-up and operate features**

Alphanumeric keypad is included as standard

- Clear text display with multilanguage support
- Possibility to use real units in monitoring
- Possibility to monitor 3 values simultaneously with Multimonitor view
- Password protection possible



Keypad equipped with memory and backup function

- Keypad equipped with memory for uploading and downloading parameters. Possibility to copy parameters from unit to unit with standard keypad
- Keypad can be used as a backup for parameter settings

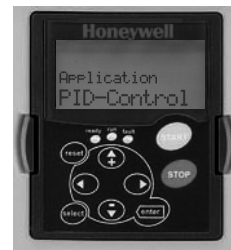

Application adapting Start Up Wizard

- Real text based wizard which guides the user through setup of all applications easily
- Start up wizard adapts to the application selected and guides the operator to do the settings which are relevant for just the application in question



Application adapting Quick Menu

- Quick menu called "Basic Parameters- group" adapts to the application selected
- Includes always the relevant parameters for just the application in question in to the group



"Keypad – Remote" Operation

- Single button operation to change the control to manual (keypad) and back
- Useful function when commissioning and testing HVAC applications.
- Consistency: all Honeywell VFDs behave in similar way



Press
LEFT ARROW for 3 s to
change control place

• **Compact and Robust design**

Features	Functions	Benefits
Enclosure Class	<ul style="list-style-type: none"> • NXS available with both IP21 and IP54 • Smallest and lightest inverter available in the market (especially IP54) 	<ul style="list-style-type: none"> • Consumes less space • Easy to install
Modular design	<ul style="list-style-type: none"> • Separated cooling channel (no electronics in air flow) • Power electronics fully enclosed in metal • Easily replaceable cooling fans 	<ul style="list-style-type: none"> • Increased reliability • Easy maintenance
Built in input AC choke and RFI filter	<ul style="list-style-type: none"> • Protection against input voltage surges • Lower total harmonic distortion THD • Fulfills all EMC requirements in buildings 	<ul style="list-style-type: none"> • Compact • No additional costs

• **Uninterruptible operation and energy saving functions**

Features	Functions	Benefits
Over Temperature ride through	Automatically adjusts switching frequency to adapt to unusual increase in ambient temperature	<ul style="list-style-type: none"> • Uninterruptible operation
Power ride through	Automatically lowers motor speed to adapt to sudden voltage drop such as power loss	<ul style="list-style-type: none"> • Uninterruptible operation
Triplex output switching	Ensures triplex operation when an output switch (e.g. safety switch) is operated between the motor and the VFD. Truly intelligent and highly reliable function to ensure better functionality than with any other VFD	<ul style="list-style-type: none"> • Uninterruptible operation
Auto restart function	Auto restart function can be configured to make VFD restart automatically once fault is addressed	<ul style="list-style-type: none"> • Uninterruptible operation
Energy Saving Function "Flux Optimization"	Flux Optimization automatically minimizes energy consumption.	<ul style="list-style-type: none"> • Even 5% increase in energy savings.

• **VFD and motor control features**

Features	Functions	Benefits
Best in performance Flying start	Ability to get an already spinning fan under speed control	<ul style="list-style-type: none"> • Important in clean room production to ensure the standard conditions
Automatic torque boost function	Boosts initial voltage to start high inertia fans	<ul style="list-style-type: none"> • Avoids tripping and enables smooth starts also to high inertia loads
Motor auto identification	Performs measurements to find out motor internal variables such as stator resistance.	<ul style="list-style-type: none"> • Increases reliability
High Switching Frequency	Honeywell NXS has higher switching frequency than the most of the competition as standard (= no derating required)	<ul style="list-style-type: none"> • Less audible noise from the motor
Prohibit frequency	Overriding the critical frequencies to avoid resonance	<ul style="list-style-type: none"> • Elimination of resonance
Temperature-controlled fans	Fan stops operating when not needed	<ul style="list-style-type: none"> • Less audible noise from VFD itself • Increase of energy savings

• **HVAC control features**

Features	Functions	Benefits
Inbuilt PID controllers	<ul style="list-style-type: none"> • Normal and Inverse Regulation • Delta P regulation with 2 standard pressure transmitters • Volume flow control • Less wiring since sensor normally close to inverter 	<ul style="list-style-type: none"> • Cost savings • Faster response in process closed loop
Sleep Mode	Shutting down the motor, when no demand	<ul style="list-style-type: none"> • Saves energy
Fire override mode	Keeps fan/pump running in case of fire	<ul style="list-style-type: none"> • Legal requirement
PFC (Pump and Fan Cascade) -Controller	Controls total pumping system with several parallel pumps by equally sharing the load	<ul style="list-style-type: none"> • Longer lifetime of the system • Lower investment cost for pumping system

• **Special application software**

Features	Functions	Benefits
Multimaster PFC	<ul style="list-style-type: none"> • The best available fully controlled pump cascade VFD system in the market • System with a VFD for each pump • Only 2 wires needed for the connection between inverters – no additional hardware • Full control over the total pumping system • Equal usage of each pump • Fully redundant system 	<ul style="list-style-type: none"> • Longer lifetime of the system • Increased reliability • Increased energy savings with optimized usage of pumps • Fully independent pump control system can be created for pumping stations

- **“ALL IN ONE” MULTIPURPOSE software**

Flexible “ALL IN ONE” multipurpose software offers predefined applications as described below for different kind of needs. This flexible package really makes it possible to answer any needs from the application with Honeywell NXS.

Basic application

- The most typical choice for HVAC - covers most of the applications
- Everything needed for basic speed control
- Includes only one small group of parameters with default values to create simple selection
- Very simple commissioning
- The control signals of this application are fixed with default functions (not configurable)
- The Basic Application is set as the default when the drive leaves the factory.

Standard application

- The 2nd most typical choice for HVAC - extended version of the basic application
- For more demanding cases where more functionality is required
- The Standard Application has the same I/O-configuration and control logic as the Basic application - i.e. no rewiring needed.
- All inputs and all outputs are freely configurable
- More functions, e.g. dynamic braking, DC braking, Prohibit Frequency for resonance elimination

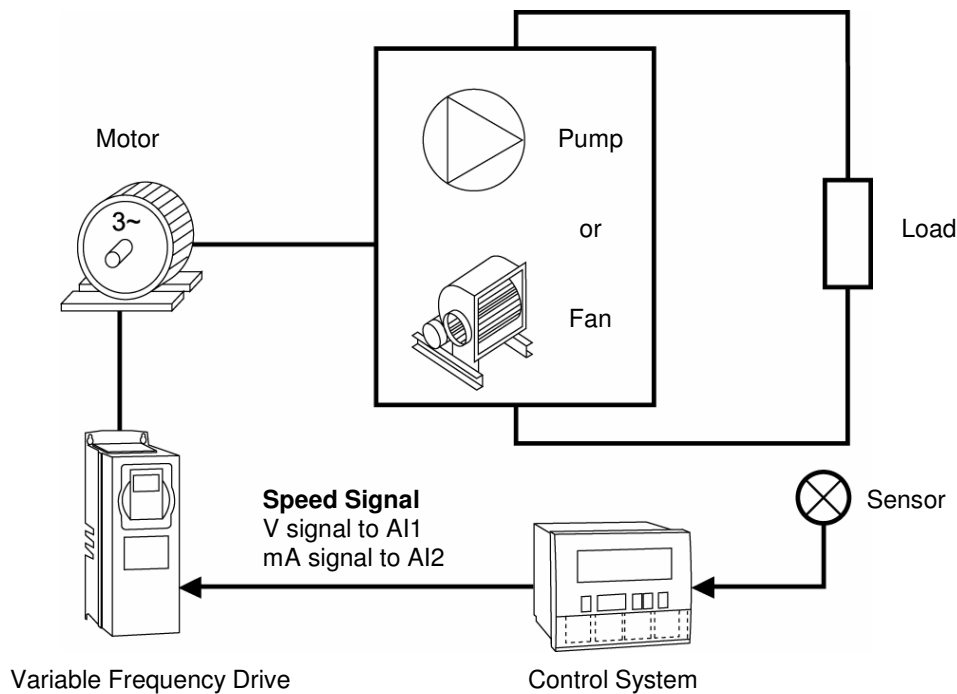

Fig. 10. Basic speed control – the typical use of basic and standard application

Local/Remote application

- The Local/Remote Control Application can be used in applications where the drive must be controlled from two different locations. control logic as the Basic application - i.e. no rewiring needed.
- The control locations (A&B) are programmable and can be selected via digital inputs.
- There can be separate references for operation and Start/Stop-inputs
- All inputs and all outputs are freely configurable

Multi-Step Speed Application

- The Multi-Step Speed Control Application can be used in applications where multiple fixed speeds are required.
- A total of 15 +2 speeds are available:
 - o one basic speed (analogue voltage or current)
 - o 15 multi-step speeds
 - o one jogging speed.
- Selection of the speeds is via digital inputs.
- Mechanical brake control available.
- All inputs and outputs are freely configurable

PID-Control Application

- The PID Control Application can be used where there is a need to keep a constant temperature or pressure etc.
- 2 control locations available (by-pass of regulator possible)
- Source A is PID-controller
 - o analogue input or a mathematical function of the analogue inputs
- Source B is a direct speed reference
 - o analogue input, a motorized potentiometer or control panel
- Stable control for a variety of tasks
- All inputs and outputs are freely configurable

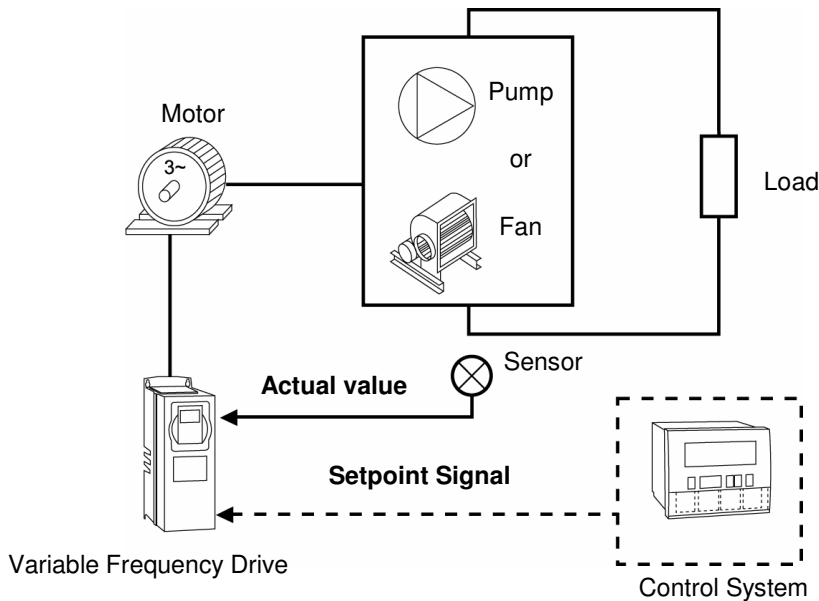

Fig. 11. PID – Control with Variable frequency drive

Multi-Purpose Control Application

- The most flexible application
- The frequency reference can be an analogue input, joystick, motor potentiometer or a mathematical function of the analogue inputs.
- Multi-step speeds or jogging speed can also be programmed.
- More programmable digital inputs
- Best option with difficult applications – all Honeywell NXS capabilities accessible through this application

PFC (Pump and Fan Cascade) Control Application

- Used for controlling a group of pumps or fans.
- The internal PID regulator controls the speed of one motor and provides start/stop commands for 1 to 4 auxiliary motors (connected directly to mains)
- Provides redundancy and high efficiency.
- Four auxiliary pumps or fans can be connected
- Autochange (if activated) allows to set the starting and stopping order of the drives, controlled by the pump and fan automatics (including the main drive)

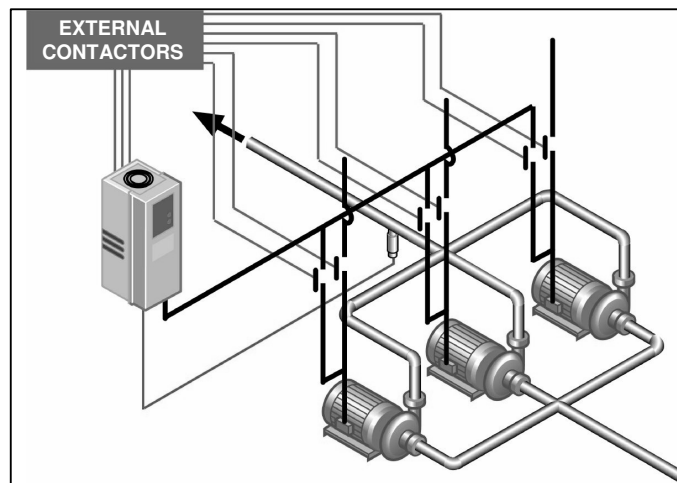

Fig. 12. PFC- controller application with autochange

- **Optional application software**

Several special application software are available for download from Honeywell support web site free of charge. And also special features can be created with the built in PLC if required. In below there is presented one of the most commonly used special applications Multimaster PFC. Special software can be downloaded from: <http://inverter.ecc.emea.honeywell.com>

Multimaster PFC (Pump and Fan Cascade) Application

- Dedicated solution for parallel pumping applications
- Unique on the market
- Replaces traditional contactor systems and can perfectly work as a stand alone system
- Fully integrated in VFD
- Only 2 wire connection required between inverters - no additional hardware
- Recommended for main pumping, booster stations, watering systems, sewage water pumping stations
- Adds reliability, minimizes risk for interruptions, fully redundant
- Functionality: PID, Autochange anytime, Sleep function

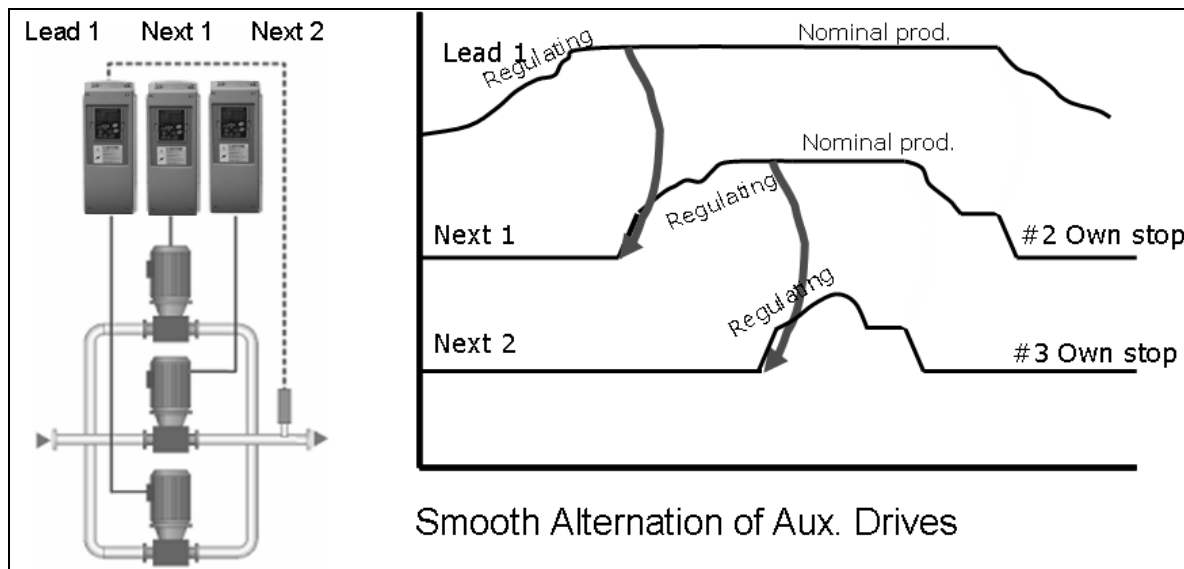

Fig. 13. Multimaster PFC system

- One NXS Inverter for each pump
- Integrated control of 2-3 pumps
- Redundant system
- Higher Efficiency at low consumption hours
- Automatic alternation without pressure spikes
- Individual or common pressure sensor
- Fewer parts than normal PFC application
- Uses Interlocks to take out pumps for service

OPTIONAL ACCESSORIES

Field bus option boards

Fieldbus	Order type code
LonWorks	OPTC4
Modbus RTU, Metasys N2	NXOPTC2
Profibus DP	NXOPTC3
CANopen (slave)	NXOPTC6
Devicenet	NXOPTC7
Modbus/TCP (Ethernet)	NXOPTCI
Bacnet MS/TP	NXOPTCJ

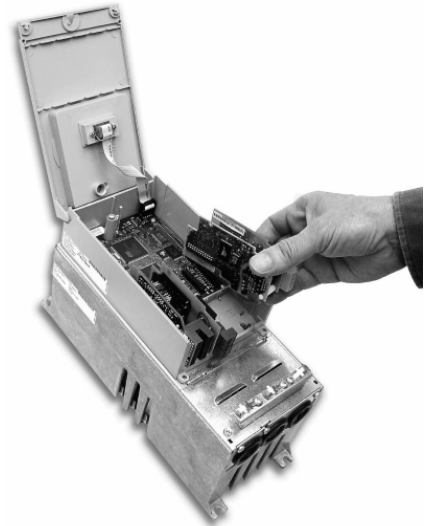

I/O expander option boards

Additional I/O	Order type code
6 Digital Inputs/Outputs (programmable)	OPTB1
1 Analogue Input (mA), 2 Analogue Output (mA)	OPTB4
3 Relays	OPTB5
1 Relay, 5 Vac inputs (42-240 Vac)	OPTB9
2 Relays, 1 Thermistor	NXOPTB2
3 Pt100 inputs	NXOPTB8

Other typical accessories

Option	Order type code	Note
Panel door installation sets	DRA02B	NXS Door installation set for display panel, 2m cable
	DRA-04B	NXS Door installation set for display panel, 4m cable
Keypad	NXPANG	NXS graphical keypad (for Chinese and Cyrillic letters)
RS232 Cables*	RS232C2M	2m RS232 serial link cable for PC connection
	RS232C-4M	4m RS232 serial link cable for PC connection

* NXS has standard RS232 connection so no additional adapters are required

SPARE PARTS

Type	Order type code	Note
Standard I/O spareparts	NXOPTA1	Standard I/O replacement for: 6DI, 1DO, 2AI(mA/V), 1AO(mA/V)
	NXOPTA3	Standard I/O replacement for: 1RO(NO/NC),1RO(NC),Therm
Keypad spareparts	NXPANA	NXS standard alphanumeric keypad
Main cooling fans	NX-FAN-4	FR4 (NXS0003-0012) main cooling fan assembly
	NX-FAN-5	FR5 (NXS0016-0031) main cooling fan assembly
	NX-FAN-6	FR6 (NXS0038-0061) main cooling fan assembly
	NX-FAN-7	FR7 (NXS0072-0105) main cooling fan assembly

Honeywell

Manufactured for and on behalf of the Environmental and Combustion Controls Division of Honeywell Technologies Sàrl, Rolle, Z.A. La Pièce 16, Switzerland by its Authorized Representative::

Automation and Control Solutions

Honeywell GmbH
 Böblinger Straße 17
 71101 Schönaich
 Germany
 Phone: (49) 7031 63701
 Fax: (49) 7031 637493
<http://ecc.emea.honeywell.com>

Subject to change without notice. Printed in Germany

EN0B0620GE51 R0611