



**MOTOROLA** **Freescale Semiconductor, Inc.** Motorola Semiconductor Israel Ltd.

COMMUNICATIONS & ADVANCED  
CONSUMER TECHNOLOGY GROUP

**MPC821 APPLICATION  
DEVELOPMENT SYSTEM  
(ADS)  
USER'S MANUAL**

Board Revision - A

Issue 0.1 - Draft 8/24/95 - ENG  
Issue 1.1a - 2/9/96 - ENG Revision  
Issue 1.2a - 5/6/96 - PILOT Revision  
Issue 1.3a - 6/26/96 - 'A' Revision

**For More Information On This Product,  
Go to: [www.freescale.com](http://www.freescale.com)**



**TABLE OF CONTENTS**

<b>1 -</b>	<b>General Information</b>	<b>1</b>
1•1	Introduction	1
1•2	Abbreviations' List	1
1•3	Related Documentation	1
1•4	SPECIFICATIONS	1
1•5	MPC821ADS Features	3
1•6	Revision Pilot to Revision A Changes	5
1•7	Revision ENG to Revision PILOT Changes	5
<b>2 -</b>	<b>Hardware Preparation and Installation</b>	<b>7</b>
2•1	INTRODUCTION	7
2•2	UNPACKING INSTRUCTIONS	7
2•3	HARDWARE PREPARATION	7
2•3•1	ADI Port Address Selection	9
2•3•2	Clock Source Selection	9
2•3•2•1	Clock Generator Replacement - U17	9
2•3•3	Power-On Reset Source Selection	10
2•3•4	VDDL Source Selection	11
2•3•5	Keep Alive Power Source Selection	11
2•4	INSTALLATION INSTRUCTIONS	12
2•4•1	Host Controlled Operation	12
2•4•2	Debug Port Controller For Target System	12
2•4•3	Stand Alone Operation	13
2•4•4	+5V Power Supply Connection	14
2•4•5	P8: +12V Power Supply Connection	14
2•4•6	ADI Installation	15
2•4•7	Host computer to MPC821ADS Connection	15
2•4•8	Terminal to MPC821ADS RS-232 Connection	15
2•4•9	Memory Installation	16
<b>3 -</b>	<b>OPERATING INSTRUCTIONS</b>	<b>17</b>
3•1	INTRODUCTION	17
3•2	CONTROLS AND INDICATORS	17
3•2•1	SOFT RESET Switch SW1	17
3•2•2	ABORT Switch SW2	17
3•2•3	HARD RESET - Switches SW1 & SW2	17
3•2•4	DS2 - Software Options Switch	17
3•2•5	J4 Power Bridge	18
3•2•6	GND Bridges	18
3•2•7	RUN Indicator - LD1	18
3•2•8	FLASH ON - LD2	18
3•2•9	DRAM ON - LD3	18
3•2•10	ETH ON - LD4	18
3•2•11	Ethernet RX Indicator - LD5	18
3•2•12	Ethernet TX Indicator - LD6	18
3•2•13	Ethernet JABB Indicator - LD7	18
3•2•14	IRD ON - LD8	18
3•2•15	Ethernet CLSN Indicator LD9	19
3•2•16	Ethernet PLR Indicator - LD10	19
3•2•17	Ethernet LIL Indicator - LD11	19

**TABLE OF CONTENTS**

3•2•18	RS232 ON - LD12	19
3•2•19	PCMCIA ON - LD13	19
3•2•20	5V Indicator - LD14	19
3•2•21	3.3V Indicator - LD15	19
3•3	MEMORY MAP	20
3•4	Programming The MPC Registers	20
3•4•1	Memory Controller Registers Programming	21
<b>4 -</b>	<b><i>Functional Description</i></b>	<b>34</b>
4•1	MPC821 Or MPC860	34
4•2	Reset & Reset - Configuration	34
4•2•1	Keep Alive Power-On Reset	34
4•2•2	Main Power - On Reset	34
4•2•3	Manual Soft Reset	34
4•2•4	Manual Hard Reset	35
4•2•5	MPC Internal Sources	35
4•2•6	Reset Configuration	35
4•2•6•1	Power - On Reset Configuration	35
4•2•6•2	Hard Reset Configuration	35
4•2•6•3	Soft Reset Configuration	36
4•3	Local Interrupter	36
4•4	Clock Generator	37
4•4•1	SPLL Support	37
4•5	Buffering	37
4•6	Chip - Select Generator	37
4•7	DRAM	38
4•7•1	DRAM 16 Bit Operation	38
4•7•2	DRAM Performance Figures	39
4•7•3	Refresh Control	40
4•7•4	Variable Bus-Width Control	41
4•8	Flash Memory	42
4•9	Ethernet Port	44
4•10	Infra - Red Port	44
4•11	RS232 Port	45
4•11•1	RS-232 Port Signal Description	45
4•12	PCMCIA Port	45
4•12•1	PCMCIA Power Control	46
4•13	LCD Port	46
4•14	Board Control & Status Register - BCSR	48
4•14•1	BCSR Disable Protection Logic	48
4•14•2	BCSR0 - Hard Reset Configuration Register	48
4•14•3	BCSR1 - Board Control Register	49
4•14•4	BCSR2 - Board Status Register - 1	51
4•14•5	BCSR3 - Auxiliary Control / Status Register	53
4•15	Debug Port Controller	56
4•15•1	MPC821ADS As Debug Port Controller For Target System	56
4•15•1•1	Debug Port Connection - Target System Requirements	57
4•15•2	Debug Port Control / Status Register	57
4•15•3	Standard MPCXXX Debug Port Connector Pin Description	58

**TABLE OF CONTENTS**

4•15•3•1	VFLS(0:1)	58
4•15•3•2	HRESET*	58
4•15•3•3	SRESET*	59
4•15•3•4	DSDI - Debug-port Serial Data In	59
4•15•3•5	DSCK - Debug-port Serial Clock	59
4•15•3•6	DSDO - Debug-port Serial Data Out	59
4•16	Power	59
4•16•1	5V Bus	61
4•16•2	3.3V Bus	61
4•16•3	2V Bus	61
4•16•4	12V Bus	61
4•16•5	Keep Alive Power	61
<b>5 -</b>	<b>Support Information</b>	<b>62</b>
5•1	Interconnect Signals	62
5•1•1	P1 ADI - Port Connector	62
5•1•2	P2 - Ethernet Port Connector	63
5•1•3	P3 - RS232 Port Connector	63
5•1•4	PCMCIA Port Connector	64
5•1•5	P5 - External Debug Port Controller Input Interconnect.	66
5•1•6	P6, P9, P10 & P12 Expansion and Logic Analyzer Connectors.	67
5•1•6•1	Connecting Application Boards to the Expansion Connectors	67
5•1•7	P7 - 5V Power Connector	88
5•1•8	P8 - 12V Power Connector	88
5•1•9	P11 - LCD Connector	88
5•1•10	P13 - QUADS Compatible Communication Connector	90
5•2	MPC821ADS Part List	95
<b>APPENDIX A -</b>	<b>Programmable Logic Equations</b>	<b>101</b>
A•1	U7 - Debug Port Controller	102
A•2	U10 - Auxiliary Board Control	126
A•3	U11 - Board Control & Status Register	142
<b>APPENDIX B -</b>	<b>ADI I/F</b>	<b>174</b>
B•1	ADI Port Signal Description	174
<b>APPENDIX C -</b>	<b>ADI Installation</b>	<b>176</b>
C•1	INTRODUCTION	176
C•2	IBM-PC/XT/AT to MPC821ADS Interface	176
C•2•1	ADI Installation in IBM-PC/XT/AT	176
C•3	SUN-4 to MPC821ADS Interface	177
C•3•1	ADI Installation in the SUN-4	178

**LIST OF FIGURES**

FIGURE 1-1	MPC821ADS Block Diagram	4
FIGURE 2-1	MPC821ADS Top Side Part Location diagram	8
FIGURE 2-2	Configuration Dip-Switch - DS1	9
FIGURE 2-3	U17 Power Sources	10
FIGURE 2-4	Power-On Reset Source Selection	11
FIGURE 2-5	VDDL Source Selection	11
FIGURE 2-6	Keep Alive Power Source Selection	12
FIGURE 2-7	Host Controlled Operation Scheme	12
FIGURE 2-8	Debug Port Controller For Target System Operation Scheme	13
FIGURE 2-9	Stand Alone Configuration	14
FIGURE 2-10	P7: +5V Power Connector	14
FIGURE 2-11	P8: +12V Power Connector	15
FIGURE 2-12	P1 - ADI Port Connector	15
FIGURE 2-13	P3 - RS-232 Serial Port Connector	16
FIGURE 2-14	Memory SIMM Installation	16
FIGURE 3-1	DS2 - Description	17
FIGURE 4-1	Refresh Scheme	40
FIGURE 4-2	DRAM Address Lines' Switching	42
FIGURE 4-3	Flash Memory SIMM Architecture	43
FIGURE 4-4	RS232 Serial Port Connector	45
FIGURE 4-5	PCMCIA Port Configuration	47
FIGURE 4-6	Debug Port Controller Block Diagram	56
FIGURE 4-7	Standard Debug Port Connector	58
FIGURE 4-8	MPC821ADS Power Scheme	60
FIGURE A-1	ADI Port Connector	174
FIGURE A-1	Physical Location of jumper JG1 and JG2	177
FIGURE A-2	JG1 Configuration Options	177
FIGURE A-3	ADI board for SBus	178

**LIST OF TABLES**

TABLE 1-1.	MPC821ADS Specifications	1
TABLE 3-1.	MPC821ADS Main Memory Map	20
TABLE 3-2.	SIU REGISTERS' PROGRAMMING	21
TABLE 3-3.	Memory Controller Initializations For 50Mhz	22
TABLE 3-4.	UPMA Initializations for 60nsec DRAMs @ 50MHz	24
TABLE 3-5.	UPMA Initializations for 70nsec DRAMs @ 50MHz	25
TABLE 3-6.	UPMA Initializations for 60nsec EDO DRAMs @ 50MHz	26
TABLE 3-7.	UPMA Initializations for 70nsec EDO DRAMs @ 50MHz	27
TABLE 3-8.	Memory Controller Initializations For 25Mhz	27
TABLE 3-9.	UPMA Initializations for 60nsec DRAMs @ 25MHz	30
TABLE 3-10.	UPMA Initializations for 70nsec DRAMs @ 25MHz	31
TABLE 3-11.	UPMA Initializations for 60nsec EDO DRAMs @ 25MHz	32
TABLE 3-12.	UPMA Initializations for 70nsec EDO DRAMs @ 25MHz	33
TABLE 4-1.	Regular DRAM Performance Figures	39
TABLE 4-2.	EDO DRAM Performance Figures	39
TABLE 4-3.	DRAM ADDRESS CONNECTIONS	42
TABLE 4-4.	Flash Memory Performance Figures	44
TABLE 4-5.	BCSR0 Description	49
TABLE 4-6.	BCSR1 Description	50
TABLE 4-7.	PCCVPP(0:1) Assignment	51
TABLE 4-8.	BCSR2 Description	52
TABLE 4-9.	Flash Presence Detect (4:1) Encoding	52
TABLE 4-10.	DRAM Presence Detect (2:1) Encoding	53
TABLE 4-11.	DRAM Presence Detect (4:3) Encoding	53
TABLE 4-12.	EXTOOLI(0:3) Assignment	53
TABLE 4-13.	BCSR3 Description	54
TABLE 4-14.	MPC821ADS Revision Number Conversion Table	54
TABLE 4-15.	FLASH Presence Detect (7:5) Encoding	55
TABLE 4-16.	Debug Port Control / Status Register	57
TABLE 4-17.	Off-board Application Maximum Current Consumption	60
TABLE 5-1	P1 - ADI Port Interconnect Signals	62
TABLE 5-2	P2 - Ethernet Port Interconnect Signals	63
TABLE 5-3	P3 - Interconnect Signals	63
TABLE 5-4.	P4 - PCMCIA Connector Interconnect Signals	64
TABLE 5-5.	P5 - Interconnect Signals	67
TABLE 5-6.	P6 - Interconnect Signals	69
TABLE 5-7.	P9 - Interconnect Signals	74
TABLE 5-8.	P10 - Interconnect Signals	79
TABLE 5-9.	P12 - Interconnect Signals	84
TABLE 5-10.	P7 - Interconnect Signals	88
TABLE 5-11.	P8 - Interconnect Signals	88
TABLE 5-12.	P11 - Interconnect Signals	89
TABLE 5-13.	P13 - Interconnect Signals	91
TABLE 5-14.	MPC821ADS Part List	95

**General Information**

**1 - General Information**

**1•1 Introduction**

This document is an operation guide for the MPC821ADS board. It contains operational, functional and general information about the ADS. The MPC821ADS is meant to serve as a platform for s/w and h/w development around the MPC821. Using its on-board resources and its associated debugger, a developer is able to load his code, run it, set breakpoints, display memory and registers and connect his own proprietary h/w via the expansion connectors, to be incorporated to a desired system with the pda.

This board could also be used as a demonstration tool, i.e., application s/w may be burned<sup>A</sup> into its flash memory and ran in exhibitions etc'.

**1•2 Abbreviations' List**

- PDA - Personal Digital Assistant, the MPC821
- UPM - User Programmable Machine
- GPCM - General Purpose Chip-select Machine
- GPL - General Purpose Line (associated with the UPM)
- I/R - Infra-Red
- MPCADS - the MPC821ADS, the subject of this document.
- BSCR - Board Control & Status Register.
- ZIF - Zero Input Force
- BGA - Ball Grid Array

**1•3 Related Documentation**

- MPC821 User's Manual.
- MC68160 Data Sheet.
- ADI Board Specification.
- 

**1•4 SPECIFICATIONS**

The MPC821ADS specifications are given in TABLE 1-1.

**TABLE 1-1. MPC821ADS Specifications**

CHARACTERISTICS	SPECIFICATIONS
Power requirements (no other boards attached)	+5Vdc @ 1.7 A (typical), 3 A (maximum) +12Vdc - @1A.
Microprocessor	MPC821 @ 50 MHz

---

A. Either on or off-board.

**General Information**

**TABLE 1-1. MPC821ADS Specifications**

CHARACTERISTICS	SPECIFICATIONS
Addressing Total address range:	4 GigaBytes
Flash Memory Dynamic RAM	2 MByte, 32 bits wide expandable to 8 MBytes 4 MByte, 36 bits wide SIMM (32 bit data, 4 bit parity) option to use higher density SIMM, up to 32 MByte
Operating temperature	0°C - 30°C
Storage temperature	-25°C to 85°C
Relative humidity	5% to 90% (non-condensing)
Dimensions: Height Depth Thickness	9.173 inches (233 mm) 7.08 inches (180 mm) 0.063 inches (1.6 mm)

ARCHIVED BY FREESCALE SEMICONDUCTOR, INC.



## General Information

### 1•5 MPC821ADS Features

- ❑ MPC821, running up to 50 MHz, mounted on ZIF BGA socket.
- ❑ 4 MBytes of 60-nsec DRAM, support is given to various types of memory varying from 4MByte configured as 1M X 32, upto 32MByte configured as 8M X 32.
- ❑ Support for EDO page mode DRAM SIMMs made by Micron - the MT8D432X and the MT16D832X.
- ❑ Automatic Dram SIMM identification.
- ❑ 2 MByte Flash SIMM. Support for upto 8 MByte.
- ❑ Automatic Flash SIMM identification.
- ❑ Memory Disable Option for all local memory map slaves.
- ❑ Board Control & Status Register - BCSR, Controlling Board's Operation.
- ❑ Programmable Hard-Reset Configuration via BCSR.
- ❑ T.P. Ethernet port via MC68160 - EEST on SCC1 with Standby Mode.
- ❑ Infra-Red Transceiver on SCC2 with Shutdown Option.
- ❑ 5V-only PCMCIA Socket With Full Buffering, Power Control and Port Disable Option. Complies with PCMCIA 2.1+ Standard.
- ❑ Module Enable Indications.
- ❑ RS232 port on SMC1 with Low-Power Option.
- ❑ On - Board Debug Port Controller with ADI I/F.
- ❑ MPC821ADS Serving as Debug Station for Target System option.
- ❑ LCD Display Connector.
- ❑ Optional Hard-Reset Configuration Burned in Flash<sup>A</sup>.
- ❑ All MPC Pins Available At Expansion & Logic Analyzer Connectors.
- ❑ External Tools' Identification Capability, via BCSR.
- ❑ Soft / Hard Reset Push - Button
- ❑ ABORT Push - Button
- ❑ Single<sup>B</sup> 5V Supply.
- ❑ Reverse / Over Voltage Protection for Power Inputs.
- ❑ 3.3V / 2V MPC Internal Logic Operation, 3.3V MPC I/O Operation.

---

A. Available only if supported also on-chip.

B. Unless a 12V supply is required for a PCMCIA card.

**General Information**

- ❑ External Keep Alive Power Source Option.
- ❑ Power Indications for Each Power Bus.
- ❑ Software Option Switch provides 16 S/W options via BCSR.

**FIGURE 1-1 MPC821ADS Block Diagram**

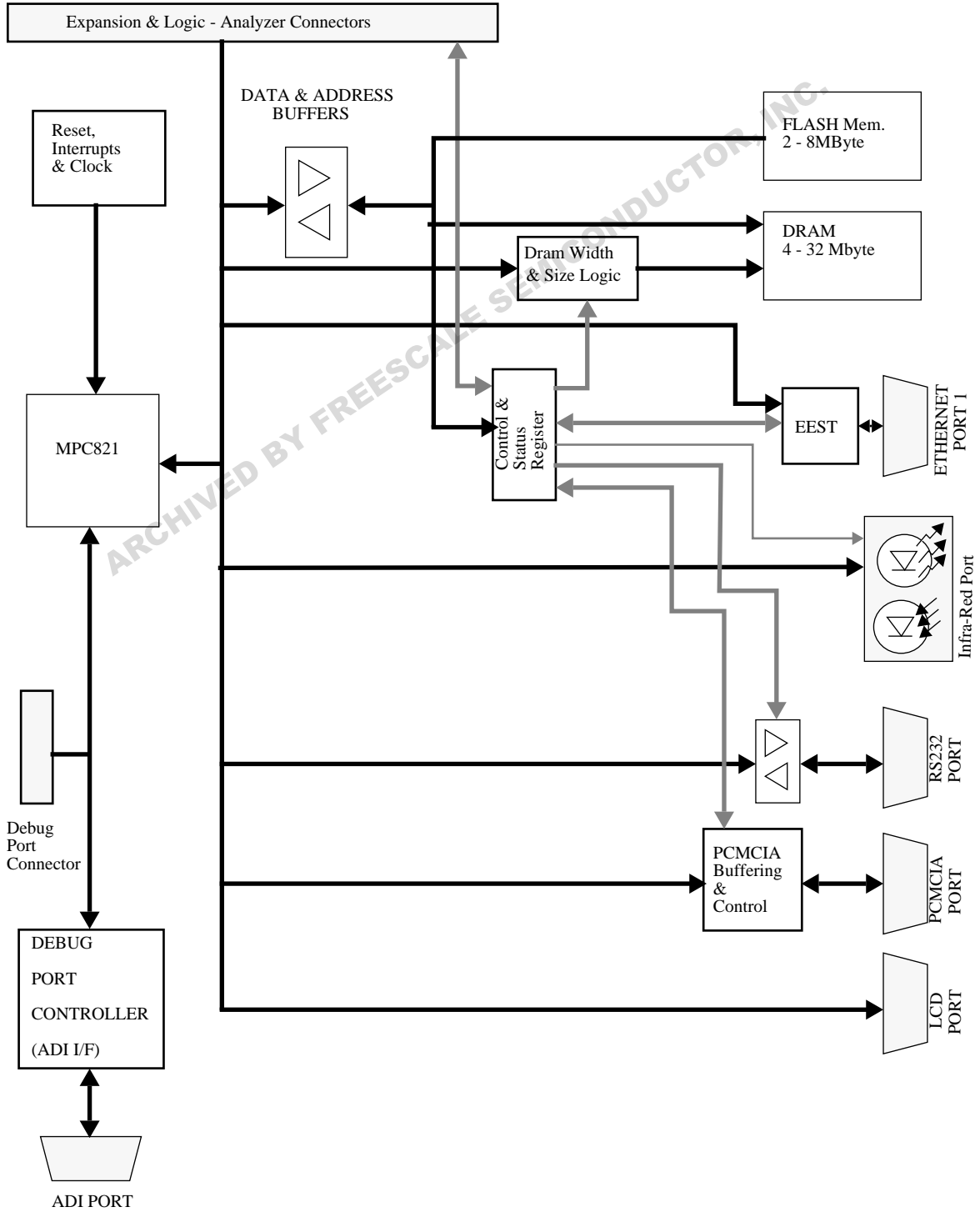

## General Information

### 1•6 Revision Pilot to Revision A Changes

- 1) DS2 which on PILOT revision was connected on SP2 with blue wires, is now integrated into the PCB, located nearby SP2.
- 2) UA38 which on revision PILOT was glued and connected with blue-wires, is now integrated into the PCB. Gate allocation within UA38, is different from revision PILOT, to provide better PCB routing.
- 3) Revision code in BCSR is changed to 2.
- 4) Added optional RA21 (0 ohm) and CA7 (0.01μF) for 10-Base-T interface network.
- 5) Some SMD pads were enlarged to assist manufacturing.

### 1•7 Revision ENG to Revision PILOT Changes

- 1) Added support for ads to function as debug station:
  - Added independent 20MHz clock generator for debug port controller
  - Added MUX (U38) so that internal logic is clocked by the above generator
  - Removed pervious debug clock logic, derived from CLKOUT of the MPC.
  - Added signal named CHINS~ (CHip-In-Socket, active-low) which is connected to one of the MPC's GND pins (isolated from GND layer). This signal controls the above mux and the indication LEDs illumination.
  - Added pull-up resistors on the Chip-Select lines, to avoid possible data-bus contention when MPC is off-socket.
  - DRAMEN~ becomes active-low to allow buffer manipulation supporting LEDs darkness when MPC off-socket. Signal RUN becomes active-high from the same reason.(Sh. 1, 7, 8, 9, 11, 14)
- 2) Signals EXTM(1:4) changed to BADDR(28:30),AS~ correspondingly, to support future external master support. (Sh. 1, 11, 13)
- 3) MODCK0 renamed to MODCK2, to comply with MPC's spec convention. (Sh 1, 3, 13)
- 4) Signal BCLOS~, which was optional for data buffers' enable logic, is found redundant and removed from ADS logic. Renamed to GPL4A~. (Sh 1, 2, 3, 12)
- 5) Added 3 Flash memory Presence Detect lines - F\_PD(5:7) to BCSR (U11/65:67) (ENG - U10) to support varying flash memory delays. (Sh 3, 4, 11)
- 6) Added support for SMART flash simms:
  - 12V VPP connected to SIMM
  - BA10 connected also to the SIMM, to support 1M X 8 devices(Sh. 4)
- 7) BCSR power on reset logic was changed to support board's power-up recovery when keep-alive power remained active. (Sh. 3, 9)
- 8) Power-on reset logic changes:
  - KA power-on reset is not driven by U10 (ENG - U9) but directly to the MPC.
  - Added AC14 (U23) powered by KAPWR to support this. (AC14's s-t is required for mach connection due to slow rise time of PORST~)
  - D3 and R12 powered from KAPWR from the same reason.
  - Added option for PON reset by main 3.3V bus. (J1)

## General Information

(Sh. 3, 9)

- 9) BA9 and BA10 are connected to U10 (ENG - U9) instead of BA11 and BA12, for flash bank selection. Bug correction. (Sh. 3)
- 10) Renewed support for 32Khz crystal:
  - CLK4IN is gated (UA38), so when working with 32768 Hz crystal, CLK4IN is driven constantly to '0'. This, to avoid clock jitter with this mode of operation.
  - Parallel resistor increased to 20MΩ.

(Sh. 7)

- 11) PLL's XFC capacitors were changed to react for formula change. Lower MF range capacitor is changed to 5nF to cover 1:5 to 1:10 MF range, while higher MF range capacitor was changed to 0.68uF to cover 1:458<sup>A</sup> to 1:1220<sup>B</sup> MF range

(Sh. 7)

- 12) PCMCIA power controller is changed to LTC1315 (by Linear Technologies):
  - PCCVPPG~ signal and indication are removed, not supported by this device
  - VPP selection code is changed.
  - DRAMEN no longer controls power to the dram.
  - Old 12V voltage pump remains as contingency for possible unavailability of the device, although the device switching outputs drive 12V. R55, R56 & R59 are therefore not assembled.

(Sh. 3, 9)

- 13) Added ADS board revision tag in BCSR.
- 14) Added signals RS\_EN~ and ETHEN~ to P13 - Quads Compatible connector, for tool designer benefit. (Sh. 16)
- 15) Added 4-switches dip-switch - DS2, connected over EXTOLI(0:3) lines, to provide s/w option selection capability.

---

A. Lowest MF allowed with 32768 Hz crystal, due to 15MHz minimal PLL frequency.

B. Highest MF allowed with 32768 Hz crystal, considering 40MHz rated MPC.

Hardware Preparation and Installation

## **2 - Hardware Preparation and Installation**

### **2•1 INTRODUCTION**

This chapter provides unpacking instructions, hardware preparation, and installation instructions for the MPC821ADS.

### **2•2 UNPACKING INSTRUCTIONS**

#### **NOTE**

If the shipping carton is damaged upon receipt, request carrier's agent to be present during unpacking and inspection of equipment.

Unpack equipment from shipping carton. Refer to packing list and verify that all items are present. Save packing material for storing and reshipping of equipment.

#### **CAUTION**

AVOID TOUCHING AREAS OF INTEGRATED CIRCUITRY; STATIC DISCHARGE CAN DAMAGE CIRCUITS.

### **2•3 HARDWARE PREPARATION**

To select the desired configuration and ensure proper operation of the MPC821ADS board, changes of the Dip-Switch settings may be required before installation. The location of the switches, LEDs, Dip-Switches, and connectors is illustrated in FIGURE 2-1. The board has been factory tested and is shipped with Dip-Switch settings as described in the following paragraphs. Parameters can be changed for the following conditions:

- ADI port address
- MPC Clock Source
- Power-On Reset Source.
- MPC Keep Alive Power Source
- MPC Internal Logic Supply Source

**Hardware Preparation and Installation**

**FIGURE 2-1 MPC821ADS Top Side Part Location diagram**

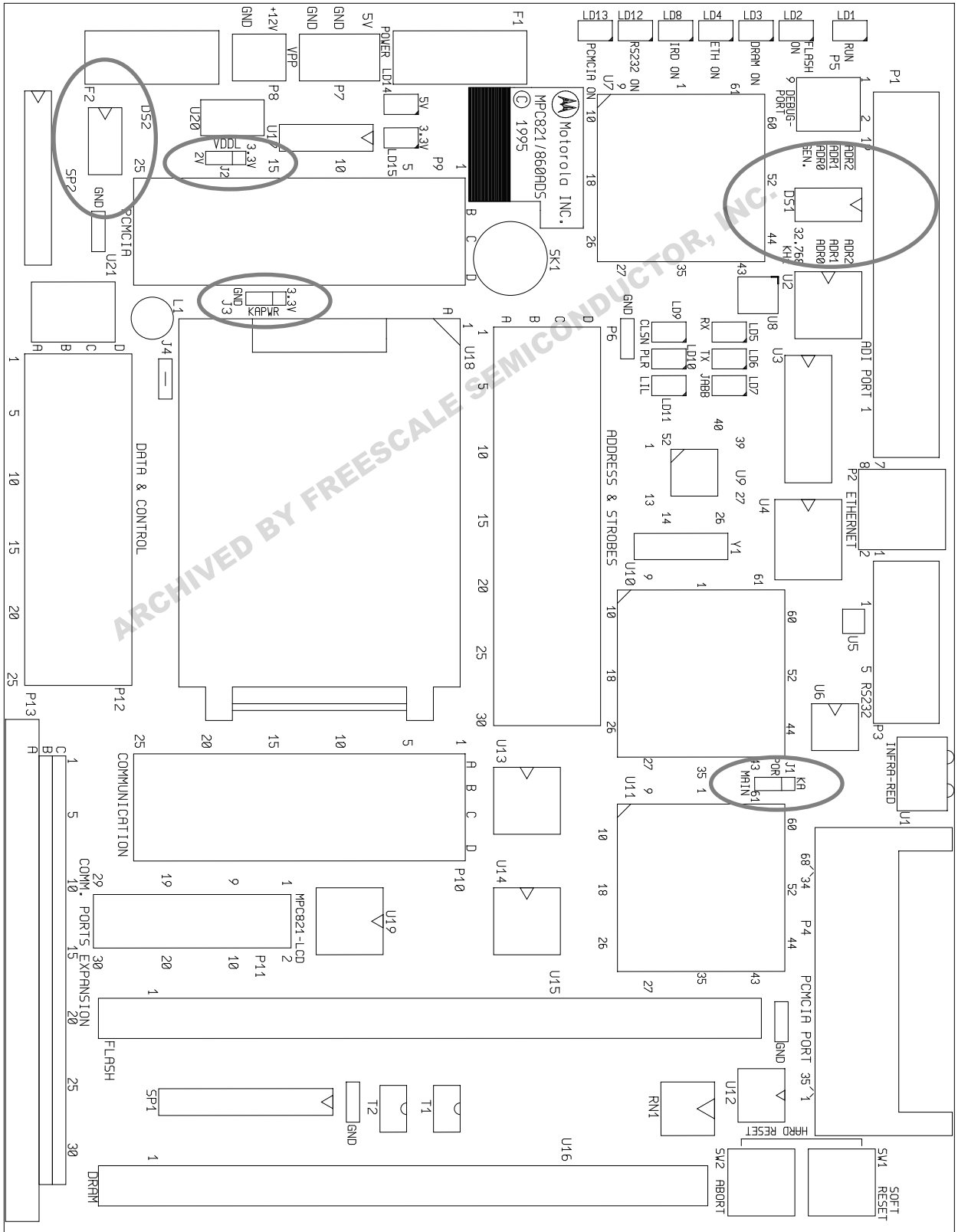

Freescale Semiconductor, Inc.

**Hardware Preparation and Installation**

**2•3•1 ADI Port Address Selection**

The MPC821ADS can have eight possible slave addresses set for its ADI port, enabling up to eight MPC821ADS boards to be connected to the same ADI board in the host computer. The selection of the slave address is done by setting switches 1, 2 & 3 in the Dip-Switch - DS1. Switch 1 stands for the most-significant bit of the address and switch 3 stands for the least-significant bit. If the switch is in the 'ON' state, it stands for logical '1'. In FIGURE 2-2 DS1 is shown to be configured to address '0'.

**FIGURE 2-2 Configuration Dip-Switch - DS1**

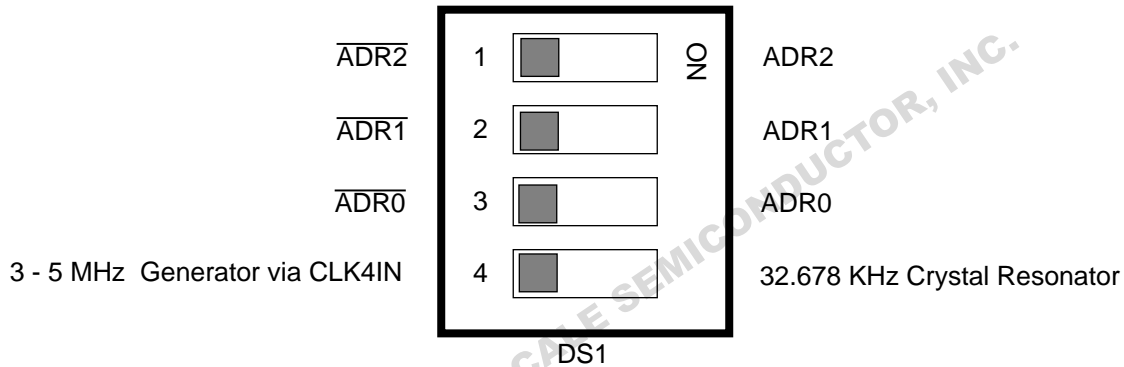

Table 2-1 describes the switch settings for each slave address:

**Table 2-1 ADI Address Selection**

ADDRESS	Switch 1	Switch 2	Switch 3
0	OFF	OFF	OFF
1	OFF	OFF	ON
2	OFF	ON	OFF
3	OFF	ON	ON
4	ON	OFF	OFF
5	ON	OFF	ON
6	ON	ON	OFF
7	ON	ON	ON

**2•3•2 Clock Source Selection**

Switch #4 on DS1 selects the clock source for the MPC. When it is in the 'ON' position while the ADS is powered-up, the on-board 32.768 KHz crystal resonator becomes the clock source and the PLL multiplication factor becomes 1:513. When switch #4 is in the 'OFF' position while the ADS is powered-up, the on-board 4<sup>A</sup>MHz clock generator (U17) becomes the clock source while the PLL multiplication factor becomes 1:5.

**2•3•2•1 Clock Generator Replacement - U17**

When replacing U17 with another clock generator it should be noticed that there are 2 supply level available at U17:

- 1) 5V supply at pin 14.

---

A. A 5MHz clock generator is provided as well.

## Hardware Preparation and Installation

- 2) 3.3V supply available at pin 11.

**FIGURE 2-3 U17 Power Sources**

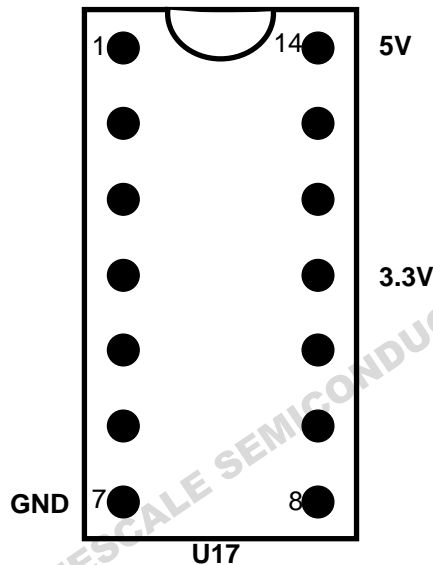

From looking at FIGURE 2-3 "U17 Power Sources" above, we see that 5V oscillator may be used with 14 pins only form-factor while 3.3V oscillators may be used with 8 pins only form-factor.

### **WARNING**

**IF A 14 Pin Form-Factor, 3.3V Clock Generator is inserted to U17, PERMANENT DAMAGE Might Be Inflicted To The Device.**

### **WARNING**

**Since the MPC clock input is NOT 5V FRIENDLY, any clock generator inserted to U17, MUST BE 3.3V compatible. If a 5V output clock generator is inserted to U17, PERMANENT DAMAGE might be inflicted to the MPC.**

### **2•3•3 Power-On Reset Source Selection**

As there are differences between MPC revisions regarding the functionality of the Power-On Reset logic, it is therefore necessary to select different sources for Power-ON reset generation.

J1 on the ADS is used to select Power-On Reset source: when a jumper is placed between positions 1 - 2 of J1, Power-On reset to the MPC is generated by the Keep-Alive power rail. I.e., When KAPWR goes below 2.005V - Power-On reset is generated. When a jumper is placed between position 2 - 3 of J1, Power-On reset to the MPC is generated from the MAIN 3.3V power rail. I.e, when the MAIN 3.3V power rail goes below 2.805V Power-On reset is generated.



**Hardware Preparation and Installation**

**FIGURE 2-4 Power-On Reset Source Selection**

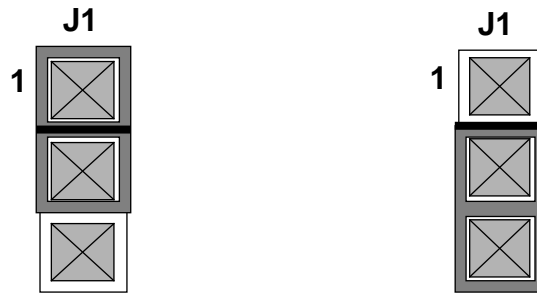

**KA Power Rail**

**MAIN Power Rail**

**2•3•4 VDDL Source Selection**

J2 serves as a selector for VDDL - MPC internal logic supply. When a jumper is placed between positions 1 - 2 of J2, VDDL is supplied with 3.3V. When a jumper is placed between positions 2 - 3 of J2, VDDL is supplied by 2V power source. The jumper on J2 is factory set between positions 1 - 2 to supply 3.3 to VDDL.

**FIGURE 2-5 VDDL Source Selection**

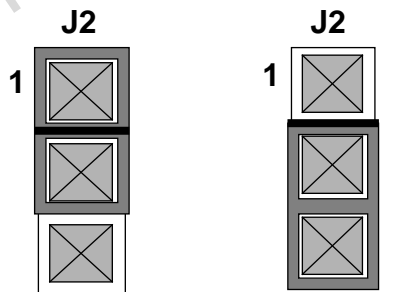

**VDDL - 3.3V**

**VDDL - 2V**

**2•3•5 Keep Alive Power Source Selection**

J3 selects the Keep Alive power source of the MPC. When a jumper is placed between positions 1 - 2 of J3, the Keep Alive power is fed from the main 3.3V bus. When an external power source<sup>A</sup> is to be connected to the Keep Alive power rail, it should be connected between positions 2 (the positive pole) and position 3 (GND) of J3.

---

A. E.g., a battery.

**Hardware Preparation and Installation**

**FIGURE 2-6 Keep Alive Power Source Selection**

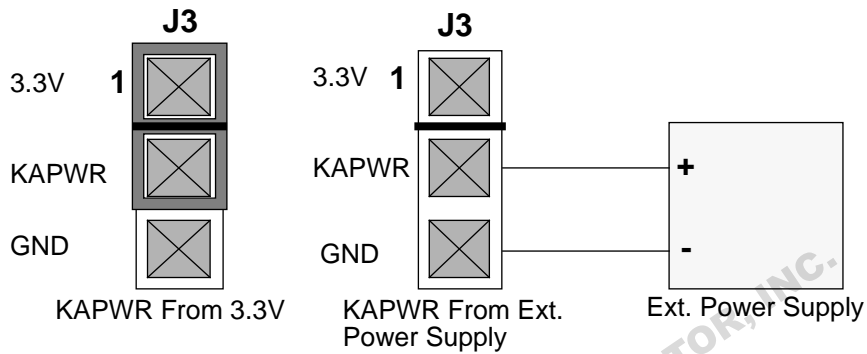

**2•4 INSTALLATION INSTRUCTIONS**

When the MPC821ADS has been configured as desired by the user, it can be installed according to the required working environment as follows:

- Host Controlled Operation
- Debug Port Controller for Target System
- Stand-Alone

**2•4•1 Host Controlled Operation**

In this configuration the MPC821ADS is controlled by a host computer via the ADI through the debug port. This configuration allows for extensive debugging using on-host debugger.

**FIGURE 2-7 Host Controlled Operation Scheme**

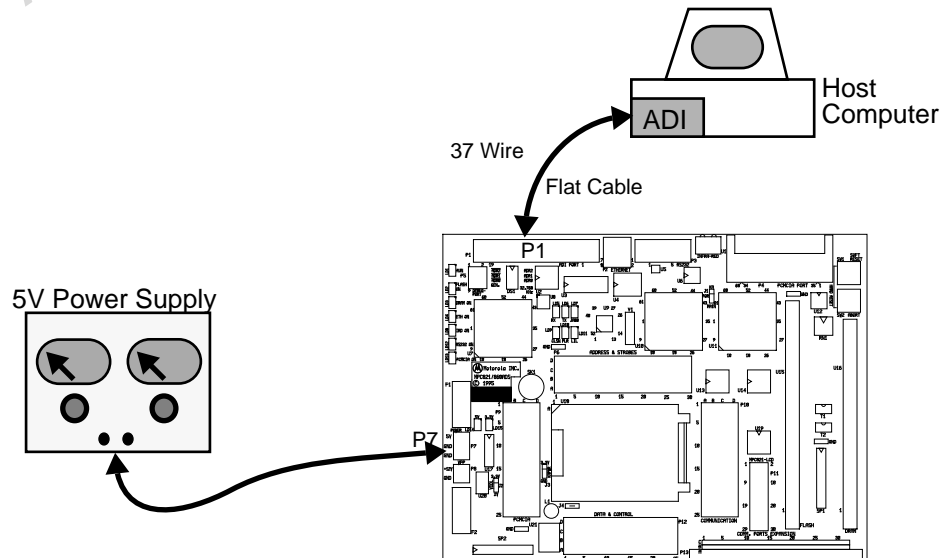

**2•4•2 Debug Port Controller For Target System**

This configuration resembles the previous, but here the local MPC is removed from its socket while the ADS is connected via a 10 lead Flat-Cable between P5 and a matching connector on a target system.

**Hardware Preparation and Installation**

**WARNING**

When connecting the ADS to a target system via P5 and a 10 lead flat-cable, the MPC **MUST** be REMOVED from its SOCKET (U18). Otherwise, **PERMANENT DAMAGE** might be inflicted to either the Local MPC or to the Target MPC.

With this mode of operation, all on-board modules are disabled and can not be accessed in anyway, except for the debug port controller. Also, all indications except for 5V power, 3.3V power and RUN are darkened.

All debugger commands and debugging features are available in this mode, including s/w download, breakpoints, etc'... The target system may be reset or interrupted by the debug port or reset by the ADS's RESET switches. It is the responsibility of the target system designer, to provide Power-On-Reset and HARD-Reset configurations, while SOFT-Reset configuration is provided by the debug-port controller. See also 4•15•1 "MPC821/860ADS As Debug Port Controller For Target System" on page 56.

**FIGURE 2-8 Debug Port Controller For Target System Operation Scheme**

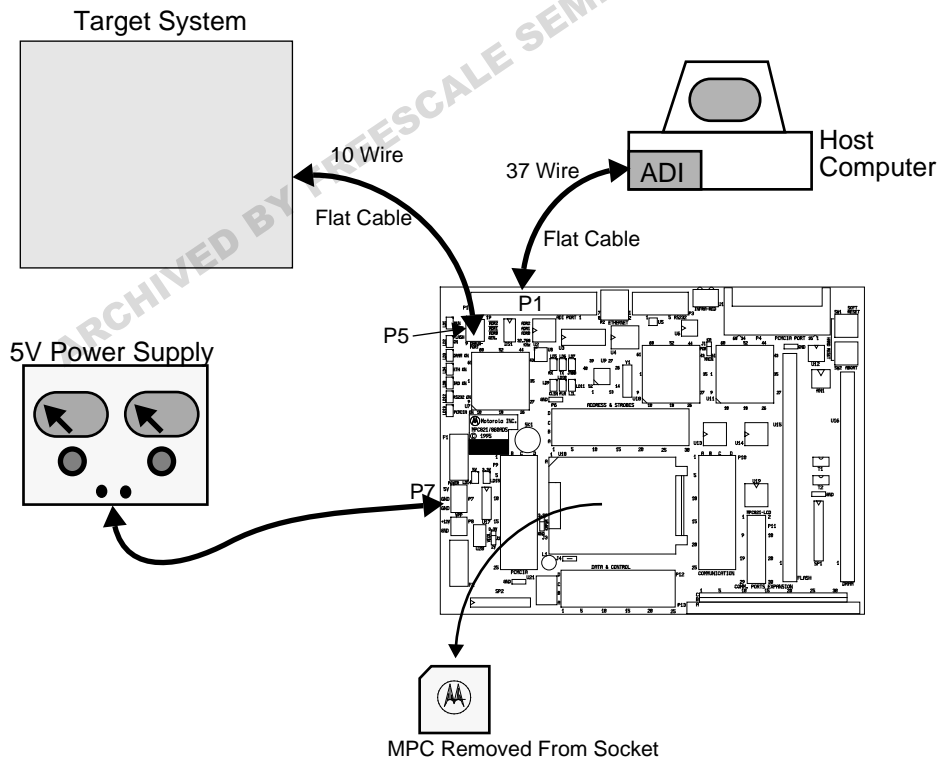

**2•4•3 Stand Alone Operation**

In this mode, the board is not controlled by the host via the ADI/Debug port. It may connect to host via one of its other ports, e.g., RS232 port, I/R port, Ethernet port, etc'. Operating in this mode requires an application program to be programmed into the board's Flash memory (while with the host controlled operation, no memory is required at all).

**Hardware Preparation and Installation**  
**FIGURE 2-9 Stand Alone Configuration**

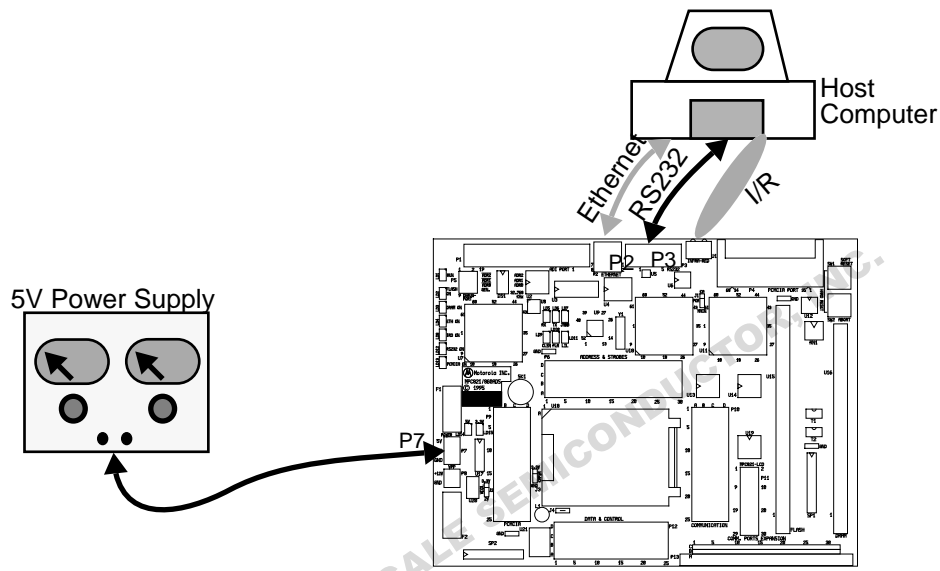

**2•4•4 +5V Power Supply Connection**

The MPC821ADS requires +5 Vdc @ 5 A max, power supply for operation. Connect the +5V power supply to connector P7 as shown below:

**FIGURE 2-10 P7: +5V Power Connector**

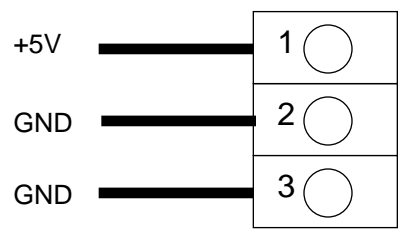

P7 is a 3 terminal block power connector with power plug. The plug is designed to accept 14 to 22 AWG wires. It is recommended to use 14 to 18 AWG wires. To provide solid ground, two Gnd terminals are supplied. It is recommended to connect both Gnd wires to the common of the power supply, while VCC is connected with a single wire.

**NOTE**

Since hardware applications may be connected to the MPC821ADS using the expansion connectors P6, P9, P10, P12 or P13, the additional power consumption should be taken into consideration when a power supply is connected to the MPC821ADS.

**2•4•5 P8: +12V Power Supply Connection**

The MPC821ADS requires +12 Vdc @ 1 A max, power supply for the PCMCIA channel Flash programming capability. The MPC821ADS can work properly without the +12V power supply, if there is no need to program a 12V programmable PCMCIA flash card.

Connect the +12V power supply to connector P6 as shown below:

**Hardware Preparation and Installation**

**FIGURE 2-11 P8: +12V Power Connector**

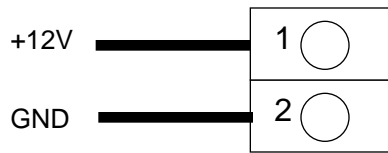

P8 is a 2 terminal block power connector with power plug. The plug is designed to accept 14 to 22 AWG wires. It is recommended to use 14 to 18 AWG wires.

**2•4•6 ADI Installation**

For ADI installation on various host computers, refer to APPENDIX C - "ADI Installation" on page 176.

**2•4•7 Host computer to MPC821ADS Connection**

The MPC821ADS ADI interface connector, P1, is a 37 pin, male, D type connector. The connection between the MPC821ADS and the host computer is by a 37 line flat cable, supplied with the ADI board. FIGURE 2-12 below shows the pin configuration of the connector.

**FIGURE 2-12 P1 - ADI Port Connector**

Gnd	20	1	N.C
Gnd	21	2	D_C~
Gnd	22	3	HST_ACK
Gnd	23	4	ADS_SRESET
Gnd	24	5	ADS_HRESET
Gnd	25	6	ADS_SEL2
(+ 12 v) N.C.	26	7	ADS_SEL1
HOST_VCC	27	8	ADS_SEL0
HOST_VCC	28	9	HOST_REQ
HOST_VCC	29	10	ADS_REQ
HOST_ENABLE~	30	11	ADS_ACK
Gnd	31	12	N.C.
Gnd	32	13	N.C.
Gnd	33	14	N.C.
PD0	34	15	N.C.
PD2	35	16	PD1
PD4	36	17	PD3
PD6	37	18	PD5
		19	PD7

NOTE: Pin 26 on the ADI is connected to +12 v power supply, but it is not used in the MPC821ADS.

**2•4•8 Terminal to MPC821ADS RS-232 Connection**

A serial (RS232) terminal or any other RS232 equipment, may be connected to the RS-232 connector P3. The RS-232 connector is a 9 pin, female, D-type connector as shown in FIGURE 2-13.

The connector is arranged in a manner that allows for 1:1 connection with the serial port of an IBM-AT<sup>A</sup> or compatibles, i.e. via a flat cable.

A. IBM-AT is a trademark of International Business Machines Inc.

**Hardware Preparation and Installation**

**FIGURE 2-13 P3 - RS-232 Serial Port Connector**

CD	1	6	DSR
TX	2	7	RTS
RX	3	8	CTS
DTR	4	9	N.C.
GND	5		

NOTE: The RTS line (pin 7) is not connected on the MPC821ADS.

**2•4•9 Memory Installation**

The MPC821ADS is supplied with two types of memory SIMM:

- Dynamic Memory SIMM
- Flash Memory SIMM.

To avoid shipment damage, these memories are packed aside rather than being installed in their sockets. Therefore, they should be installed on site. To install a memory SIMM, it should be taken out of its package, put diagonally in its socket (no error can be made here, since the Flash socket has 80 contacts, while the DRAM socket has 72) and then twisted to a vertical position until the metal lock clips are locked. See FIGURE 2-14 "Memory SIMM Installation" below.

**CAUTION**

The memory SIMMs have alignment nibble near their # 1 pin. It is important to align the memory correctly before it is twisted, otherwise damage might be inflicted to both the memory SIMM and its socket.

**FIGURE 2-14 Memory SIMM Installation**

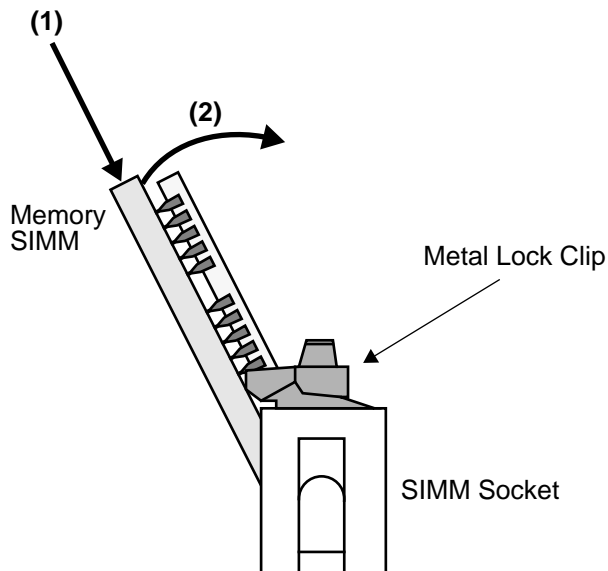

**OPERATING INSTRUCTIONS**

**3 - OPERATING INSTRUCTIONS**

**3•1 INTRODUCTION**

This chapter provides necessary information to use the MPC821ADS in host-controlled and stand-alone configurations. This includes controls and indicators, memory map details, and software initialization of the board.

**3•2 CONTROLS AND INDICATORS**

The MPC821ADS has the following switches and indicators.

**3•2•1 SOFT RESET Switch SW1**

The SOFT RESET switch SW1 performs Soft reset to the MPC internal modules, maintaining MPC's configuration (clocks & chip-selects) and dram contents. The switch signal is debounced, and it is not possible to disable it by software. At the end of the Soft Reset Sequence, the Soft Reset Configuration is sampled and becomes valid.

**3•2•2 ABORT Switch SW2**

The ABORT switch is normally used to abort program execution, this by issuing a level 0 interrupt to the MPC. If the ADS is in stand alone mode<sup>A</sup>, it is the responsibility of the user to provide means of handling the interrupt, since there is no resident debugger with the MPC821ADS. The ABORT switch signal is debounced, and can not be disabled by software.

**3•2•3 HARD RESET - Switches SW1 & SW2**

When BOTH switches - SW1 and SW2 are depressed simultaneously, HARD reset is generated to the MPC. When the MPC is HARD reset, all its configuration is lost, including data stored in the DRAM and the MPC has to be re-initialized. At the end of the Hard Reset sequence, the Hard Reset Configuration stored in BCSR0 becomes valid.

**3•2•4 DS2 - Software Options Switch**

DS2 is a 4-switches Dip-Switch, mounted over SP2. This switch is connected over EXTOLI(0:3) lines, and since EXTOLI(0:3) lines are available at BCSR, S/W options may be manually selected, according to DS2 state.

**FIGURE 3-1 DS2 - Description**

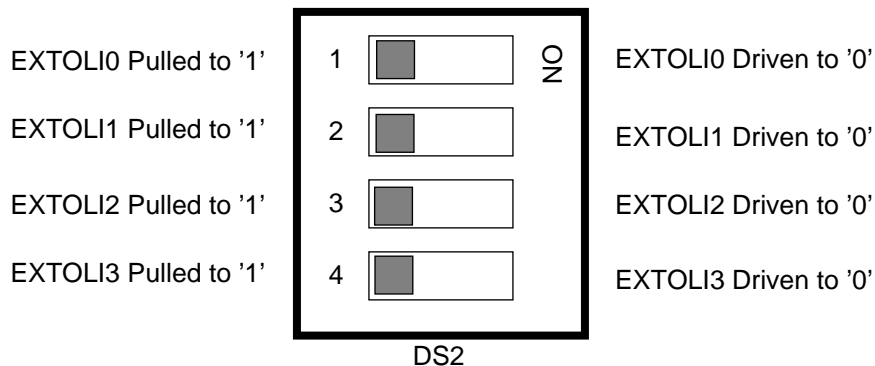

A. I.e., detached from a debug station.

## OPERATING INSTRUCTIONS

### 3•2•5 J4 Power Bridge

J4 is a soldered jumper, which is in series with the 3.3V power bus. This jumper may be removed<sup>A</sup> if current measurements on the 3.3V bus are to be held.

#### **Warning**

There are also GND bridges on board, which physically resemble J4. Do not mistake J4 to be a GND jumper, otherwise, permanent damage might be inflicted to the MPC821ADS.

### 3•2•6 GND Bridges

There are 4 GND bridges on the MPC821ADS. They are meant to assist general measurements and logic-analyzer connection.

#### **Warning**

When connecting to a GND bridge, use only INSULATED GND clips. Failure in doing so, might result in permanent damage to the MPC821ADS.

### 3•2•7 RUN Indicator - LD1

When the green RUN led - LD1 is lit, it indicates that the MPC is not in debug mode, i.e., VFLS0 & VFLS1 == 0. It is important to remember, that if the VFLS(0:1) pins are programmed for alternative use rather than function as VFLS lines, this indication is meaningless.

### 3•2•8 FLASH ON - LD2

When the yellow FLASH ON led is lit, it indicates that the FLASH module is enabled in the BCSR1 register. I.e., any access done to the CS0~ address space will hit the flash memory. When it is dark, the flash is disabled and CS0~ may be used off-board via the expansion connectors.

### 3•2•9 DRAM ON - LD3

When the yellow DRAM ON led is lit, it indicates the DRAM is enabled in BCSR1. Therefore, any access made to CS1~ (or CS2~) will hit on the DRAM. When it is dark, it indicates that either the DRAM is disabled in BCSR1, enabling the use of CS1~ and CS2~ off-board via the expansion connectors.

### 3•2•10 ETH ON - LD4

When the yellow ETH ON led is lit, it indicates that the ethernet port transceiver - the MC68160 EEST, connected to SCC1 is active. When it is dark, it indicates that the EEST is in power down mode, enabling the use of SCC1 pins off-board via the expansion connectors.

### 3•2•11 Ethernet RX Indicator - LD5

The green Ethernet Receive LED indicator blinks whenever the EEST is receiving data from one of the Ethernet port.

### 3•2•12 Ethernet TX Indicator - LD6

The green Ethernet Receive LED indicator blinks whenever the EEST is transmitting data via the Ethernet port.

### 3•2•13 Ethernet JABB Indicator - LD7

The red Ethernet TP Jabber LED indicator - JABB, lights whenever a jabber condition is detected on the TP ethernet port.

### 3•2•14 IRD ON - LD8

---

A. By a skilled technician only.



## OPERATING INSTRUCTIONS

When the yellow IRD ON led is lit, it indicates that the Infra-Red transceiver - the TFDS3000, connected to SCC2, is active and enables communication via that medium. When it is dark, the I/R transceiver is in shutdown mode, enabling the use of SCC2 pins off-board via the expansion connectors.

### **3•2•15 Ethernet CLSN Indicator LD9**

The red Ethernet Collision LED indicator CLSN, blinks whenever a collision condition is detected on the ethernet port, i.e., simultaneous receive and transmit.

### **3•2•16 Ethernet PLR Indicator - LD10**

The red Ethernet TP Polarity LED indicator - PLR, lights whenever the wires connected to the receiver input of the ethernet port are reversed. The LED is lit by the EEST, and remains on while the EEST has automatically corrected for the reversed wires.

### **3•2•17 Ethernet LIL Indicator - LD11**

The yellow Ethernet Twisted Pair Link Integrity LED indicator - LIL, lights to indicate good link integrity on the TP port. The LED is off when the link integrity fails.

### **3•2•18 RS232 ON - LD12**

When the yellow RS232 ON led is lit, it designates that the RS232 transceiver connected to SMC1, is active and communication via that medium is allowed. When dark, it designates that the transceiver is in shutdown mode, so SMC1 pins may be used off-board via the expansion connectors.

### **3•2•19 PCMCIA ON - LD13**

When the yellow PCMCIA ON led is lit, it indicates the following:

- 1) Address & strobe buffers are driven towards the PCMCIA card
- 2) Data buffers may be driven to / from the PCMCIA card depending on the CE1A~ and CE2A~ signals and transfer direction.
- 3) Card status lines are driven towards the MPC from the PCMCIA card.

When it is dark, it indicates that all the above buffers are tri-stated and the pins associated with PCMCIA channel A, may be used off-board via the expansion connectors.

### **3•2•20 5V Indicator - LD14**

The yellow 5V led, indicates the presence of the +5V supply at P7.

### **3•2•21 3.3V Indicator - LD15**

The yellow 3.3V led indicates that the 3.3V power bus is powered

**OPERATING INSTRUCTIONS**

**3•3 MEMORY MAP**

All accesses to MPC821ADS's memory slaves are controlled by the MPC's memory controller. Therefore, the memory map is reprogrammable to the desire of the user. After Hard Reset is performed by the debug station, the debugger checks to see the size, delay and type of the DRAM and FLASH memory mounted on board and initializes the chip-selects accordingly. The DRAM and the FLASH memory respond to all types of memory access i.e., user / supervisory, program / data and DMA.

**TABLE 3-1. MPC821ADS Main Memory Map**

ADDRESS RANGE	Memory Type	Device Type				Port Size
00000000 - 003FFFFFFF	DRAM SIMM	MCM36100	MCM36200	MCM36400	MCM36800	32
00400000 - 007FFFFFFF	DRAM SIMM		MCM36200	MCM36400	MCM36800	32
00800000 - 00FFFFFFF	DRAM SIMM			MCM36400	MCM36800	32
01000000 - 01FFFFFFF	DRAM SIMM				MCM36800	32
02000000 - 020FFFFFFF	Empty Space					
02100000 - 02103FFF	BCSR(0:3) <sup>a</sup>					32 <sup>b</sup>
02104000 - 021FFFFFFF	Empty Space					
02200000 - 02207FFF	MPC Internal MAP <sup>c</sup>					32
02208000 - 027FFFFFFF	Empty Space					
02800000 - 029FFFFFFF	Flash SIMM	MCM29F020	MCM29F040 SM732A1000A	MCM29F080 SM732A2000		32
02A00000 - 02BFFFFFFF			MCM29F040 SM732A1000A	MCM29F080 SM732A2000		32
02C00000 - 02FFFFFFF				MCM29F080 SM732A2000		32

a. The device appears repeatedly in multiples of its size. E.g., BCSR0 appears at memory locations 2100000, 2100010, 2100020..., while BCSR1 appears at 2100004, 2100014, 2100024... and so on.

b. Only upper 16 bit are in fact used.

c. Refer to the MPC821 User's Manual for complete description of the MPC internal memory map.

**3•4 Programming The MPC Registers**

The MPC provides the following functions on the MPC821ADS:

- 1) DRAM Controller
- 2) Chip Select generator.
- 3) UART for terminal or host computer connection.
- 4) Ethernet controller.
- 5) Infra-Red Port Controller
- 6) General Purpose I/O signals.

**OPERATING INSTRUCTIONS**

The internal registers of the MPC must be programmed after Hard reset as described in the following paragraphs. The addresses and programming values are in hexadecimal base.

For better understanding the of the following initializations refer to the MPC821 User's Manual for more information.

**TABLE 3-2. SIU REGISTERS' PROGRAMMING**

Register	Init Value[hex]	Description
SIUMCR	01632440	Internal arbitration, External master arbitration priority - 0, External arbitration priority - 0, PCMCIA channel II pins - debug pins, Debug Port on JTAG port pins, FRZ/IRQ6~ - IRQ6~, debug register - locked, No parity for non-CS regions, DP(0:3)/IRQ(3:6)~ pins - DP(0:3), reservation disabled, SPKROUT - Tri-stated, BS_A(0:3)~ and WE(0:3)~ are driven just on their dedicated pins, GPL_B5~ enabled, GPL_A/B(2:3)~ function as GPLs.
SYPCR	FFFFFF88	Software watchdog timer count - FFFF, Bus-monitor timing FF, Bus-monitor - Enabled, S/W watch-dog - Freeze, S/W watch-dog - disabled, S/W watch-dog (if enabled) causes NMI, S/W (if enabled) not prescaled.
TBSCR	00C2	No interrupt level, reference match indications cleared, interrupts disabled, no freeze, time-base disabled.
RTCSC	01C2	Interrupt request level - 1, 32768 Hz source, second interrupt disabled, Alarm interrupt disabled, Real-time clock - FREEZE, Real-time clock disabled.
PISCR	0082	No level for interrupt request, Periodic interrupt disabled, clear status, interrupt disabled, FREEZE, periodic timer disabled.

**3•4•1 Memory Controller Registers Programming**

The memory controller on the MPC821ADS is initialized to 50 MHz operation. I.e., registers' programming is based on 50 MHZ timing calculation except for refresh timer which is initialized to 16.67Mhz, the lowest frequency at which the ADS may wake up. Since the ADS may be made to wake-up at 25MHz<sup>A</sup> as well, the initializations are not efficient, since there are too many wait-states inserted. Therefore, additional set of initialization is provided to support efficient 25MHz operation.

The reason for initializing the ADS for 50Mhz is to allow proper (although not efficient) ADS operation through all available ADS clock operation frequencies.

---

A. The only parameter which is initialized to the start-up frequency, is the refresh rate, which would have been inadequate if initialized to 50Mhz while board is running at a lower frequency. Therefore, for best bus bandwidth availability, refresh rate should be adapted to the current system clock frequency.

**OPERATING INSTRUCTIONS**

**Warning**

Due to availability problems with few of the supported memory components, the below initializations were not tested with all parts. Therefore, the below initializations are liable to CHANGE, throughout the testing period.

**TABLE 3-3. Memory Controller Initializations For 50Mhz**

Register	Device Type	Init Value [hex]	Description
BR0	All Flash SIMMs supported.	02200001	Base at 2200000, 32 bit port size, no parity, GPCM
OR0	MCM29F020-90	FFE00D34	2MByte block size, all types access, CS early negate, 6 w.s., Timing relax
	MCM29F040-90 SM732A1000A-9	FFC00D34	4MByte block size, all types access, CS early negate, 6 w.s., Timing relax
	MCM29F080-90 SM732A2000-9	FF800D34	8MByte block size, all types access, CS early negate, 6 w.s., Timing relax
	MCM29F020-12	FFE00D44	2MByte block size, all types access, CS early negate, 8 w.s., Timing relax
	MCM29F040-12 SM732A1000A-12	FFC00D44	4MByte block size, all types access, CS early negate, 8 w.s., Timing relax
	MCM29F080-12 SM732A2000-12	FF800D44	8MByte block size, all types access, CS early negate, 8 w.s., Timing relax
BR1	BCSR	02100001	Base at 2100000, 32 bit port size, no parity, GPCM
OR1	BCSR	FFFF8110	32 KByte block size, all types access, CS early negate, 1 w.s.
BR2	All Dram SIMMs Supported	00000081	Base at 0, 32 bit port size, no parity, UPMA
OR2	MCM36100/200-60/70	FFC00800	4MByte block size, all types access, initial address multiplexing according to AMA.
	MCM36400/800-60/70 MT8/16D432/832X-6/7	FF000800	16MByte block size, all types access, initial address multiplexing according to AMA.
BR3	MCM36200-60/70	00400081	Base at 400000, 32 bit port size, no parity, UPMA
	MCM36800-60/70 MT16D832X-6/7	01000081	Base at 1000000, 32 bit port size, no parity, UPMA
OR3	MCM36200-60/70	FFC00800	4MByte block size, all types access, initial address multiplexing according to AMA
	MCM36800-60/70 MT16D832X-6/7	FF000800	16MByte block size, all types access, initial address multiplexing according to AMA.
MPTPR	All Dram SIMMs Supported	0400	Divide by 16 (decimal)

**OPERATING INSTRUCTIONS**

**TABLE 3-3. Memory Controller Initializations For 50Mhz**

Register	Device Type	Init Value [hex]	Description
MAMR	MCM36100-60/70	40A21114 <sup>a</sup> 60A21114 <sup>b</sup> C0A21114 <sup>c</sup>	refresh clock divided by 40 <sup>a</sup> or 60 <sup>b</sup> or C0 <sup>c</sup> , periodic timer enabled, type 2 address multiplexing scheme, 1 cycle disable timer, GPL4 disabled for data sampling edge flexibility, 1 loop read, 1 loop write, 4 beats refresh burst.
	MCM36200-60/70	20A21114 <sup>a</sup> 30A21114 <sup>b</sup> 60A21114 <sup>c</sup>	refresh clock divided by 20 <sup>a</sup> or 30 <sup>b</sup> or 60 <sup>c</sup> , periodic timer enabled, type 2 address multiplexing scheme, 1 cycle disable timer, GPL4 disabled for data sampling edge flexibility, 1 loop read, 1 loop write, 4 beats refresh burst.
	MCM36400-60/70 MT8D432X-6/7	40B21114 <sup>a</sup> 60B21114 <sup>b</sup> C0B21114 <sup>c</sup>	refresh clock divided by 40 <sup>a</sup> or 60 <sup>b</sup> or C0 <sup>c</sup> , periodic timer enabled, type 3 address multiplexing scheme, 1 cycle disable timer, GPL4 disabled for data sampling edge flexibility, 1 loop read, 1 loop write, 4 beats refresh burst.
	MCM36800-60/70 MT16D832-6/7	20B21114 <sup>a</sup> 30B21114 <sup>b</sup> 60B21114 <sup>c</sup>	refresh clock divided by 20 <sup>a</sup> or 30 <sup>b</sup> or 60 <sup>c</sup> , periodic timer enabled, type 3 address multiplexing scheme, 1 cycle disable timer, GPL4 disabled for data sampling edge flexibility, 1 loop read, 1 loop write, 4 beats refresh burst.

- a. Assuming 16.67 MHz BRGCLK.
- b. Assuming 25MHz BRGCLK
- c. For 50MHz BRGCLK

**OPERATING INSTRUCTIONS**

**TABLE 3-4. UPMA Initializations for 60nsec DRAMs @ 50MHz**

Cycle Type	Single Read	Burst Read	Single Write	Burst Write	Refresh	Exception	
Offset in UPM	0	8	18	20	30	3C	
Contents @ Offset +	0	8FFFECC24	8FFFECC24	8FAFCC24	8FAFCC24	C0FFCC84	33FFCC07
	1	0FFFECC04	0FFFECC04	0FAFCC04	0FAFCC04	00FFCC04	X
	2	0CFFFECC04	08FFFECC04	0CAFCC00	0CAFCC00	07FFCC04	X
	3	00FFFECC04	00FFFECC0C	11BFCC47	03AFCC4C	3FFFCC06	X
	4	00FFFECC00	03FFFECC00	X	0CAFCC00	FFFFCC85	
	5	37FFFECC47	00FFFECC44	X	03AFCC4C	FFFFCC05	
	6	X	00FFCC08	X	0CAFCC00	X	
	7	X	0CFFCC44	X	03AFCC4C	X	
	8		00FFFECC0C		0CAFCC00	X	
	9		03FFFECC00		33BFCC4F	X	
	A		00FFFECC44		X	X	
	B		00FFCC00		X	X	
	C		3FFFCC847		X		
	D		X		X		
	E		X		X		
	F		X		X		

Freescale Semiconductor, Inc.

**OPERATING INSTRUCTIONS**

**TABLE 3-5. UPMA Initializations for 70nsec DRAMs @ 50MHz**

Cycle Type		Single Read	Burst Read	Single Write	Burst Write	Refresh	Exception
Offset In UPM		0	8	18	20	30	3C
Contents @ Offset +	0	8FFFCC24	8FFFCC24	8FAFCC24	8FAFCC24	E0FFCC84	33FFCC07
	1	0FFFCC04	0FFFCC04	0FAFCC04	0FAFCC04	00FFCC04	X
	2	0CFFCC04	0CFFCC04	0CAFCC00	0CAFCC00	00FFCC04	X
	3	00FFCC04	00FFCC04	11BFCC47	03AFCC4C	00FFCC04	X
	4	00FFCC00	00FFCC08	X	0CAFCC00	7FFFCC06	
	5	37FFCC47	0CFFCC44	X	03AFCC4C	FFFFCC85	
	6	X	00FFEC0C	X	0CAFCC00	FFFFCC05	
	7	X	03FFEC00	X	03AFCC4C	X	
	8		00FFEC44		0CAFCC00	X	
	9		00FFCC08		33BFCC47	X	
	A		0CFFCC44		X	X	
	B		00FFEC04		X	X	
	C		00FFEC00		X		
	D		3FFFEC47		X		
	E		X		X		
	F		X		X		

**OPERATING INSTRUCTIONS**

**TABLE 3-6. UPMA Initializations for 60nsec EDO DRAMs @ 50MHz**

Cycle Type		Single Read	Burst Read	Single Write	Burst Write	Refresh	Exception
Offset in UPM		0	8	18	20	30	3C
Contents @ Offset +	0	8FFBEC24	8FFFECC24	8FFFCC24	8FFFCC24	C0FFCC84	33FFCC07
	1	0FF3EC04	0FFBEC04	0FEFCC04	0FEFCC04	00FFCC04	X
	2	0CF3EC04	0CF3EC04	0CAFCC00	0CAFCC00	07FFCC04	X
	3	00F3EC04	00F3EC0C	11BFCC47	03AFCC4C	3FFFCC06	X
	4	00F3EC00	0CF3EC00	X	0CAFCC00	FFFFCC85	
	5	37F7EC47	00F3EC4C	X	03AFCC4C	FFFFCC05	
	6	X	0CF3EC00	X	0CAFCC00	X	
	7	X	00F3EC4C	X	03AFCC4C	X	
	8		0CF3EC00		0CAFCC00	X	
	9		00F3EC44		33BFCC4F	X	
	A		03F3EC00		X	X	
	B		3FF7EC47		X	X	
	C		X		X		
	D		X		X		
	E		X		X		
	F		X		X		

Freescale Semiconductor, Inc.



**OPERATING INSTRUCTIONS**

**TABLE 3-7. UPMA Initializations for 70nsec EDO DRAMs @ 50MHz**

Cycle Type		Single Read	Burst Read	Single Write	Burst Write	Refresh	Exception
Offset In UPM		0	8	18	20	30	3C
Contents @ Offset +	0	8FFBCC24	8FFFCC24	8FFFCC24	8FFFCC24	E0FFCC84	33FFCC07
	1	0FF3CC04	0FFBCC04	0FEFCC04	0FEFCC04	00FFCC04	X
	2	0CF3CC04	0CF3CC04	0CAFCC00	0CAFCC00	00FFCC04	X
	3	00F3CC04	00F3CC0C	11BFCC47	03AFCC4C	0FFFCC04	X
	4	00F3CC00	03F3CC00	X	0CAFCC00	7FFFCC04	
	5	37F7CC47	00F3CC44	X	03AFCC4C	FFFFCC86	
	6	X	00F3EC0C	X	0CAFCC00	FFFFCC05	
	7	X	0CF3EC00	X	03AFCC4C	X	
	8		00F3EC4C		0CAFCC00	X	
	9		03F3EC00		33BFCC47	X	
	A		00F3EC44		X	X	
	B		00F3CC00		X	X	
	C		33F7CC47		X		
	D		X		X		
	E		X		X		
	F		X		X		

**TABLE 3-8. Memory Controller Initializations For 25Mhz**

Register	Device Type	Init Value [hex]	Description
BR0	All Flash SIMMs supported.	02200001	Base at 2200000, 32 bit port size, no parity, GPCM

**OPERATING INSTRUCTIONS**

**TABLE 3-8. Memory Controller Initializations For 25Mhz**

Register	Device Type	Init Value [hex]	Description
OR0	MCM29F020-90	FFE00D20	2MByte block size, all types access, CS early negate, 2 w.s.
	MCM29F040-90 SM732A1000A-9	FFC00D20	4MByte block size, all types access, CS early negate, 2 w.s.
	MCM29F080-90 SM732A2000-9	FF800920	8MByte block size, all types access, CS early negate, 2 w.s., Timing relax
	MCM29F020-12	FFE00D30	2MByte block size, all types access, CS early negate, 3 w.s.
	MCM29F040-12 SM732A1000A-12	FFC00D30	4MByte block size, all types access, CS early negate, 3 w.s.
	MCM29F080-12 SM732A2000-12	FF800930	8MByte block size, all types access, CS early negate, 3 w.s.
BR1	BCSR	02100001	Base at 2100000, 32 bit port size, no parity, GPCM
OR1	BCSR	FFFF8110	32 KByte block size, all types access, CS early negate, 1 w.s.
BR2	All Dram SIMMs Supported	00000081	Base at 0, 32 bit port size, no parity, UPMA
OR2	MCM36100/200-60/70	FFC00800	4MByte block size, all types access, initial address multiplexing according to AMA.
	MCM36400/800-60/70 MT8/16D432/832X-6/7	FF000800	16MByte block size, all types access, initial address multiplexing according to AMA.
BR3 <sup>a</sup>	MCM36200-60/70	00400081	Base at 400000, 32 bit port size, no parity, UPMA
	MCM36800-60/70 MT16D832X-6/7	01000081	Base at 1000000, 32 bit port size, no parity, UPMA
OR3	MCM36200-60/70	FFC00800	4MByte block size, all types access, initial address multiplexing according to AMA
	MCM36800-60/70 MT16D832X-6/7	FF000800	16MByte block size, all types access, initial address multiplexing according to AMA.
MPTPR	All Dram SIMMs Supported	0400	Divide by 16 (decimal)

**OPERATING INSTRUCTIONS**

**TABLE 3-8. Memory Controller Initializations For 25Mhz**

Register	Device Type	Init Value [hex]	Description
MAMR	MCM36100-60/70	60A21114	refresh clock divided by 60, periodic timer enabled, type 2 address multiplexing scheme, 1 cycle disable timer, GPL4 disabled for data sampling edge flexibility, 1 loop read, 1 loop write, 4 beats refresh burst.
	MCM36200-60/70	30A21114	refresh clock divided by 30, periodic timer enabled, type 2 address multiplexing scheme, 1 cycle disable timer, GPL4 disabled for data sampling edge flexibility, 1 loop read, 1 loop write, 4 beats refresh burst.
	MCM36400-60/70 MT8D432X-6/7	60B21114	refresh clock divided by 60, periodic timer enabled, type 3 address multiplexing scheme, 1 cycle disable timer, GPL4 disabled for data sampling edge flexibility, 1 loop read, 1 loop write, 4 beats refresh burst.
	MCM36800-60/70 MT16D832-6/7	30B21114	refresh clock divided by 30, periodic timer enabled, type 3 address multiplexing scheme, 1 cycle disable timer, GPL4 disabled for data sampling edge flexibility, 1 loop read, 1 loop write, 4 beats refresh burst.

a. BR3 is not initialized for 36100 or 36400 DRAM SIMMs.

**OPERATING INSTRUCTIONS**

**TABLE 3-9. UPMA Initializations for 60nsec DRAMs @ 25MHz**

Cycle Type		Single Read	Burst Read	Single Write	Burst Write	Refresh	Exception
Offset in UPM		0	8	18	20	30	3C
Contents @ Offset +	0	0FFFCC04	0FFFCC24	0FAFCC24	0FAFCC04	80FFCC84	33FFCC07
	1	08FFCC00	08FFCC00	08AFCC00	08AFCC00	13FFCC04	X
	2	33FFCC47	03FFCC4C	3FBFCC47	01AFCC48	FFFFCC87	X
	3	X	08FFCC00	X	08AFCC44	FFFFCC05	X
	4	X	03FFCC4C	X	0FAFCC08	X	
	5	X	08FFCC00	X	08AFCC44	X	
	6	X	03FFCC4C	X	0CAFCC08	X	
	7	X	08FFCC00	X	38BFCC46	X	
	8		33FFCC47		FFFFCC45	X	
	9		X		X	X	
	A		X		X	X	
	B		X		X	X	
	C		X		X		
	D		X		X		
	E		X		X		
	F		X		X		

**OPERATING INSTRUCTIONS**

**TABLE 3-10. UPMA Initializations for 70nsec DRAMs @ 25MHz**

Cycle Type		Single Read	Burst Read	Single Write	Burst Write	Refresh	Exception
Offset In UPM		0	8	18	20	30	3C
Contents @ Offset +	0	0FF FEC04	0FF FCC24	0FA FCC04	0FA FCC04	C0FF CC84	33FF CC07
	1	08FF EC04	0FFF CC04	08A FCC00	0CA FCC00	01FF CC04	X
	2	00FF EC00	08FF CC00	3FB FCC47	01A FCC4C	7FFF CC86	X
	3	3FFF EC47	03FF CC4C	X	0CA FCC00	FFFF CC05	X
	4	X	08FF CC00	X	01A FCC4C	X	
	5	X	03FF CC4C	X	0CA FCC00	X	
	6	X	08FF CC00	X	01A FCC4C	X	
	7	X	03FF CC4C	X	0CA FCC00	X	
	8		08FF CC00		31B FCC43	X	
	9		33FF CC47		X	X	
	A		X		X	X	
	B		X		X	X	
	C		X		X		
	D		X		X		
	E		X		X		
	F		X		X		

**OPERATING INSTRUCTIONS**

**TABLE 3-11. UPMA Initializations for 60nsec EDO DRAMs @ 25MHz**

Cycle Type		Single Read	Burst Read	Single Write	Burst Write	Refresh	Exception
Offset in UPM		0	8	18	20	30	3C
Contents @ Offset +	0	0FFBCC04	0FFBCC04	0FEFCC04	0FEFCC04	80FFCC84	33FFCC07
	1	0CF3CC04	09F3CC0C	08AFCC04	08AFCC00	13FFCC04	X
	2	00F3CC00	09F3CC0C	00AFCC00	07AFCC48	FFFFCC87	X
	3	33F7CC47	09F3CC0C	0FBFCC47	08AFCC48	FFFFCC05	X
	4	X	08F3CC00	X	08AFCC48	X	
	5	X	3FF7CC47	X	39BFCC47	X	
	6	X	X	X		X	
	7	X	X	X		X	
	8		X			X	
	9		X			X	
	A		X		X	X	
	B		X		X	X	
	C		X		X		
	D		X		X		
	E		X		X		
	F		X		X		

**OPERATING INSTRUCTIONS**

**TABLE 3-12. UPMA Initializations for 70nsec EDO DRAMs @ 25MHz**

Cycle Type		Single Read	Burst Read	Single Write	Burst Write	Refresh	Exception
Offset In UPM		0	8	18	20	30	3C
Contents @ Offset +	0	0FFBCC04	0FFBEC04	0FEFCC04	0FEFCC04	C0FFCC84	33FFCC07
	1	0CF3CC04	08F3EC04	08AFCC04	08AFCC00	01FFCC04	X
	2	00F3CC00	03F3EC48	00AFCC00	07AFCC4C	7FFFCC86	X
	3	33F7CC47	08F3CC00	0FBFCC47	08AFCC00	FFFFCC05	X
	4	X	0FF3CC4C	X	07AFCC4C	X	
	5	X	08F3CC00	X	08AFCC00	X	
	6	X	0FF3CC4C	X	07AFCC4C	X	
	7	X	08F3CC00	X	08AFCC00	X	
	8		3FF7CC47		37BFCC47	X	
	9		X		X	X	
	A		X		X	X	
	B		X		X	X	
	C		X		X		
	D		X		X		
	E		X		X		
	F		X		X		

Freescale Semiconductor, Inc.

## Functional Description

# 4 - Functional Description

In this chapter the various modules combining the MPC821ADS are described to their design details.

### **4•1 MPC821**

The MPC821 runs @ frequencies from 15<sup>A</sup> - 50 MHz and is buffered from the rest of the board's logic - this to allow for external hardware development via dedicated expansion connectors. P6, P9, P10 & P12.

### **4•2 Reset & Reset - Configuration**

There are several reset sources on the MPCADS:

- 1) Keep Alive Power-On Reset
- 2) Main Power On Reset
- 3) Manual Soft-Reset
- 4) Manual Hard-Reset
- 5) Debug Port Soft-Reset
- 6) Debug Port Hard-Reset
- 7) MPC Internal Sources.

#### **4•2•1 Keep Alive Power-On Reset**

The Keep Alive Power - On Reset on the MPC821ADS is generated by a dedicated voltage detector made by Seiko the S-8051HN-CD-X with detection voltage range of 1.795 to 2.005V. This voltage detector is connected to the Keep Alive power input of the MPC and during keep alive power-on or when there is a voltage drop of that input into the above range and J1 is set accordingly (see 2•3•3 "Power-On Reset Source Selection" on page 10), Power-On Reset is generated, i.e., PORESET\* input of the MPC is asserted for a period of approximately 4 sec.

When PORESET\* is asserted to the MPC, the Power-On reset configuration is made available to MPC. See 4•2•6•1 "Power - On Reset Configuration" on page 35.

#### **4•2•2 Main Power - On Reset**

The Main power on reset generates HARD reset and optionally PON reset, when the MAIN 3.3V bus is powered-on or there is a drop of voltage level over this bus. The reset is generated by a dedicated voltage detector made by Seiko the S-8052ANY-NH-X with detection voltage range of 2.595 to 2.805V. When regular power-on reset conditions exist, the HRESET\* signal of the MPC is asserted for a period of approximately 4 sec. In addition, if J1 is set accordingly (see 2•3•3 "Power-On Reset Source Selection" on page 10), Power-On Reset is generated, i.e., PORESET\* input of the MPC is asserted for a period of approximately 4 sec.

When HRESET signal is asserted, the HARD reset configuration is made available to the MPC. See 4•2•6•2 "Hard Reset Configuration" on page 35.

When PORESET\* is asserted to the MPC, the Power-On reset configuration is made available to MPC. See 4•2•6•1 "Power - On Reset Configuration" on page 32.

#### **4•2•3 Manual Soft Reset**

To support resident application development and debuggers, a soft reset push-button is provided. Depressing that button, asserts the SRESET\* pin of the MPC, generating a SOFT RESET sequence. This

---

A. The MPC's PLL minimal frequency is 15MHz. Below that, the Low-Power-Divider must be incorporated, during the operation of which, CLKOUT is no longer 50% duty-cycle, distorting UPM timing.



## Functional Description

button is debounced to avoid spikes over the SRESET\* line.

When SRESET\* signal is asserted, the SOFT reset configuration is made available to the MPC. See 4•2•6•3 "Soft Reset Configuration" on page 36.

### 4•2•4 Manual Hard Reset

To support resident application development, a hard reset push-button is provided<sup>A</sup>. When the soft reset push-button is depressed in conjunction with the ABORT push-button, the HRESET\* line is asserted, generating a HARD RESET sequence. The button sharing is for economy and board space saving and does not effect in any way, functionality.

### 4•2•5 MPC Internal Sources

Since the HRESET\* and SRESET\* lines of the MPC are open-drain and the on-board reset logic drives these lines with open-drain gates, the correct operation of the internal reset sources of the MPC is facilitated. As a rule, an internal reset source will assert HRESET\* and / or SRESET\* for a minimum time of 512 system clocks. It is beyond the scope of this document to describe these sources, however Debug-Port Soft / Hard Resets which are part of the development support system<sup>B</sup>, are regarded as such.

### 4•2•6 Reset Configuration

During reset sequences to their kinds, the MPC device samples the state of some external pins to determine its operation modes and pin configuration. There are 3 kinds of reset levels to the MPC, each level having its own configuration sampled:

- 1) Power - On Reset configuration
- 2) Hard Reset configuration
- 3) Soft Reset Configuration.

#### 4•2•6•1 Power - On Reset Configuration

Just before PORESET\* is negated by the external logic, the power-on reset configuration which include the MODCK(1:2) pins is sampled. These pins determine the clock operation mode of the MPC. Two clock modes are supported within the MPC821ADS:

- 1) 1:5 PLL operation via on-board clock generator.

In this mode MODCK(1:2) are driven with '11' during<sup>C</sup> power on reset.

- 2) 1:513 PLL operation via on-board clock generator.

In this mode MODCK(1:2) are driven with '10'. during power-on reset.

#### 4•2•6•2 Hard Reset Configuration

During HARD reset sequence, when RSTCONF\* pin is asserted, the data bus state is sampled to acquire the MPC's hard reset configuration. The reset configuration word is driven by BCSR0 register, defaults of which are set during power-on reset. The BCSR0 drives the half configuration word, i.e., data bits D(0:15) in which the reserved bits are designated RSRVxx. If the hard-reset configuration is to be changed<sup>D</sup>, BCSR0 may be written with new values, which become valid after HARD reset is applied to the ADS.

On the MPCADS, the RSTCONF\* line is always driven during HARD reset, i.e., no use is possible with the MPC's internal HARD reset configuration defaults.

To allow user programmable, full-word hard reset configuration, i.e., D(0:31) lines being driven during HARD reset, an option is provided for Flash memory driven hard reset configuration. I.e., the desired hard-

---

A. It is not a dedicated button.

B. And therefore mentioned.

C. The MODCK lines are in fact driven longer - by HRESET~ line.

D. With respect the ADS's power-on defaults.

## Functional Description

reset configuration word is taken from the first word of the Flash memory. During hard-reset this word drives the data bus to set the desired configuration. To support this option, CS0~ of the MPC should be asserted<sup>A</sup> during HARD reset and the ADDRESS lines should be driven low. The selection of this option is done via BCSR1. See TABLE 4-6. "BCSR1 Description" on page 50.

The system parameters to which BCSR0 defaults during power-on reset and are driven at hard-reset are listed below:

- 1) Arbitration: internal arbitration is selected.
- 2) Interrupt Prefix: The internal default is interrupt prefix at 0xFFFF0000. It is overridden to provide interrupt prefix at address 0, which is located within the DRAM.
- 3) Boot Disable: Boot is enabled.
- 4) Boot Port Size: 32 bit boot port size is selected.
- 5) Initial Internal Space Base: Immediately after HARD reset, the internal space is located at \$FF000000.
- 6) Debug pins configuration: PCMCIA port B pins become debug support pins<sup>B</sup>.
- 7) Debug port pins configuration. Debug port pins are on the JTAG port.
- 8) External Bus Division Factor: 1:1 internal to external clocks ratio is selected.

### 4•2•6•3 Soft Reset Configuration

The rising edge of SRESET\* is used to configure the development port. Before the negation of SRESET\*, DSCK<sup>C</sup> is sampled to determine for debug-mode enable / disable. After SRESET\* is negated, if debug mode was enabled, DSCK is sampled again for debug-mode entry / non-entry.

DSDI is used to determine the debug port clock mode and is sampled after the negation of SRESET\*.<sup>D</sup>

The Soft Reset configuration is provided by the debug-port controller U7 via the ADI I/F. When an ADI bundle is connected, i.e., a debug station is connected, debug mode is always enabled, while immediate entry is determined by the debug station. When a bundle is not connected to the ADI port, or disconnected from the host computer, debug mode is disabled by means of pulling DSCK low via a pull-down resistor.

## 4•3 Local Interrupter

The only external interrupt applied to the MPC via its interrupt controller is the ABORT (NMI), which is generated by a push-button - SW2. When this button is depressed, the NMI input to the MPC is asserted (low). The purpose of this type of interrupt, is support the use of resident debuggers if any is made available to the MPCADS. All other interrupts to the MPC, are generated internally by the MPC's peripherals and by the debug port.

To support external (off-board) generation of an NMI, the IRQ0\* line which drives the MPC's NMI, is driven by an open-drain gate. This allows for external h/w to also drive this line. If an external h/w indeed does so, it is compulsory that IRQ0\* is driven by an open-drain (or open-collector) gate.

## 4•4 Clock Generator

There are 2 ways to clock the MPC on the MPC821ADS:

- 1) 3 - 5MHz Clock generator connected to CLK4IN input. 1:5 PLL mode.

---

A. May be supported on future revisions of the MPC.

B. I.e., AT, VF, VFLS...

C. DSCK is configured at hard-reset to reside on the JTAG port.

D. With parts from the MPC5XX family DSDI is sampled prior (3 system-clock cycles) to the negation of SRESET\*, to determine the part's configuration source: internal (default) or external via data bus.

## Functional Description

- 2) 32.768 KHz crystal resonator via EXTAL-XTAL pair of the MPC, 1:513 initial PLL multiplication factor.

The clock generator (1) above, is a 3.3V operated, or 5V operated with 3.3V compatible output.

The selection between the above modes is done using switch #4 of DS1. See 2•3•2 "Clock Source Selection" on page 9. See also 4•2•6 "Reset Configuration" on page 35. DS1/4 has dual functionality: it is responsible to the combination driven to the MODCK lines during power-on reset and to the connection of the appropriate capacitor between XFC and VDDSYN lines to match the PLL's multiplication factor. When 1:5 mode is selected, a capacitor of 5nF is connected, while when 1:513 mode is selected a 0.68μF capacitor is connected parallel to it via a TMOS gate. The capacitors' values are calculated to support a wider range of multiplication factors as possible.

When mode (2) above is selected, the output of the clock generator is gated from CLK4IN and driven to '0' constantly so that a jitter-free system clock is generated.

### 4•4•1 SPLL Support

Since the SPLL requires quiet supplies, GNDSYN and GNDSYN1 have a dedicated ground plane connected only in one point to the global ground plane of the ads. Bypassing capacitors pairs of 0.1μF and 0.01μF are connected as close as possible between VDDSYN and GNDSYN. VDDSYN is filtered from the digital supply using a LC filter with a double pole @ app. 500 hz to provide satisfactory<sup>A</sup> attenuation of switching regulators noise over PLL supply lines.

### 4•5 Buffering

As the MPCADS is meant to serve also as a hardware development platform, it is necessary to buffer the MPC from the local bus, so the MPC's capacitive drive capability is not wasted internally and remains available for user's off-board applications via the expansion connectors.

Since the total capacitive load over the address lines of all local memory slaves is significant, two parallel sets of buffers are provided for address - a dedicated group for the Flash memory and PCMCIA (U29, U33 & U34) and a dedicated group for the DRAM (part of U30 and U32). Strobe lines are also buffered (U30, U35 & U37) while transceivers are provided for data (U39 - U42).

The data transceivers open only if there is an access to a valid<sup>B</sup> board address or during Hard - Reset configuration<sup>C</sup>. That way data conflicts are avoided in case an off-board memory is read, provided that it is not mapped to an address valid on board. It is the users' responsibility to avoid such errors.

### 4•6 Chip - Select Generator

The memory controller of the MPC is used as a chip-select generator to access on-board<sup>D</sup> memories, saving board's area reducing cost, power consumption and increasing flexibility. To enhance off-board application development, memory modules (including the BCSRx) may be disabled via BCSR1<sup>E</sup> in favor of an external memory connected via the expansion connectors. That way, a CS line may be used off-board via the expansion connectors, while its associated local memory is disabled.

When a CS region is disabled via BCSR1, the local data transceivers are not open during access to that

---

A. Approximately -45dB @ 5KHz.

B. An address which is covered in a Chip-Select region and that CS region is enabled via BCSR1.

C. To allow a configuration word stored in Flash memory become active.

D. And off-board. See further.

E. After the BCSR is removed from the local memory map, there is no way to access it but to remove and re-apply power to the ADS.

## Functional Description

region, avoiding possible<sup>A</sup> contention over data lines.

The MPC's chip-selects assignment to the various memories / registers on the MPCADS are as follows:

- 1) CS0\* - Flash memory
- 2) CS1\* - BCSR
- 3) CS2\* - DRAM Bank 1.
- 4) CS3\* - DRAM Bank 2 (if exists).
- 5) CS(4:7)\* - Unused, user available.

### 4•7 DRAM

The MPC821ADS is supplied with 4 MBytes of DRAM, with access time of 60 or 70 nsec. Support is given to memory capacity from 4 MByte with no parity upto 32MByte with parity. Support is given to and only to the following devices made by Motorola:

MCM36100AS60, MCM36100AS70, MCM36100ASG60, MCM36100ASG70 MCM36100ASH60, MCM36100ASH70, MCM36100ASHG60, MCM36100ASHG70, MCM36200AS60, MCM36200AS70, MCM36200ASG60, MCM36200ASG70, MCM36400AS60, MCM36400AS70, MCM36400ASG60, MCM36400ASG70, MCM36400ASH60, MCM36800S60, MCM36800S70, MCM36800SG60, MCM36800SG70. MCM36100ASH70, MCM36100ASHG60, MCM36100ASHG70

Also supported are 5V EDO memory SIMMs made by Micron: MT8D132M-6X (4 MByte), MT16D232M-6X (8 MByte), MT8D432M-6X (16Mbyte), MT16D832M-6X (32 MByte), MT8D432M-7X and MT16D832M-6X.

All dram configurations are supported via the Board Control & Status Register (BCSR), i.e., DRAM size (4M to 32M) and delay (60 / 70 nsec) are read from BCSR2 and the associated registers (including the UPM) are programmed accordingly.

Dram timing control is performed by UPMA of the MPC via CS2 (and CS3 for 2-bank SIMM) region(s), i.e., RAS and CAS signals' generation, during normal<sup>B</sup> access as well as during refresh cycles and the necessary address multiplexing<sup>C</sup> are performed using UPM1. CS2\* and CS3\* signals are buffered from the DRAM and each split to 2 to overcome the capacitive load over the dram SIMM RAS lines. The programming of UPM1 and other associated registers to perform that task is described in 3•4•1 "Memory Controller Registers Programming" on page 21.

The DRAM module may enabled / disabled at any time by writing the DRAMEN~ bit in BCSR1. See TABLE 4-6. "BCSR1 Description" on page 50.

#### 4•7•1 DRAM 16 Bit Operation

To enhance evaluation capabilities, support is given to 16-bit and 32-bit data bus width. That way users can tailor dram configuration, to get best fit to their application requirements. When the DRAM is in 16 bit mode, half of it is not used, i.e., memory portion that is connected to data lines D(16:31) is not used at all.

To configure the DRAM for 16 bit data bus width operation, the following steps should be taken:

- 1) Set the Dram\_Half\_Word bit in BCSR1 to Half-Word. See TABLE 4-6. "BCSR1 Description" on page 50
- 2) The Port Size bits of BR2~ (and of BR3~ for a 2-bank DRAM SIMM) should be set to 16 bits.

A. During read cycles.

B. Normal i.e.: Single Read, Single Write, Burst Read & Burst Write.

C. Taking into account support for narrower bus widths.

**Functional Description**

- 3) The AM bits in OR2 register should be set to **1/2** of the nominal **single-bank** DRAM simm volume or to **1/4** of the nominal **dual-bank** DRAM simm volume.

If a Dual-Bank DRAM simm is being used:

- 4) The Base-Address bits in BR3 register should be set to DRAM\_BASE + 1/4 Nominal\_Volume, that is, if a contiguous block of memory is desired.
- 5) The AM bits of OR3 register, should be set to 1/4 Nominal\_Volume.

If the above is executed out of running code, than this code should not reside on the DRAM while executing, otherwise, erratic behavior is likely to be demonstrated, resulting in a system crash.

**4•7•2 DRAM Performance Figures**

The performance figures for the dram as reflected from the initializations given in 3•4•1 "Memory Controller Registers Programming" on page 21 are shown in TABLE 4-1. "Regular DRAM Performance Figures" on page 39 and in TABLE 4-2. "EDO DRAM Performance Figures" on page 39.

**TABLE 4-1. Regular DRAM Performance Figures**

System Clock Frequency [MHz]	Number of System Clock Cycles			
	50		25	
DRAM Delay [nsec]	60	70	60	70
Single Read	6	6	3	4
Single Write	4	4	3	3
Burst Read	6,2,3,2	6,3,2,3	3,2,2,2	4,2,2,2
Burst Write	4,2,2,2	4,2,2,2	3,1,2,2	3,2,2,2
Refresh	21 <sup>a b</sup>	25 <sup>a b</sup>	13 <sup>a b</sup>	13 <sup>a b</sup>

- a. Four-beat refresh burst.
- b. Not including arbitration overhead.

**TABLE 4-2. EDO DRAM Performance Figures**

System Clock Frequency [MHz]	Number of System Clock Cycles			
	50		25	
DRAM Delay [nsec]	60	70	60	70
Single Read	6	6	3	4
Single Write	4	4	2	3
Burst Read	6,2,2,2	6,3,2,2	3,1,1,1	4,1,2,2
Burst Write	4,2,2,2	4,2,2,2	2,1,1,1	3,2,2,2
Refresh	21 <sup>a b</sup>	25 <sup>a b</sup>	13 <sup>a b</sup>	13 <sup>a b</sup>

### Functional Description

- a. Four-beat refresh burst.
- b. Not including arbitration overhead.

#### 4•7•3 Refresh Control

The refresh to the dram is a CAS before RAS refresh, which is controlled by UPMA as well. The refresh logic is clocked by the BRG clock which is not influenced by the low-power divider.

**FIGURE 4-1 Refresh Scheme**

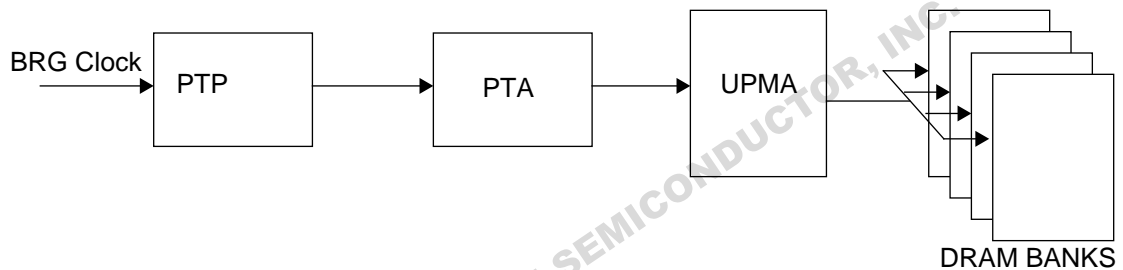

As seen in FIGURE 4-1 "Refresh Scheme" above, the BRG clock is twice divided: once by the PTP (Periodic Timer Prescaler) and again by another prescaler - the PTA, dedicated for each UPM. If there are more than one dram banks, than refresh cycles are performed for consecutive banks, therefore, refresh should be made faster. The formula for calculation of the PTA is given below:

$$PTA = \frac{\text{Refresh\_Period} \times \text{Number\_Of\_Beats\_Per\_Refresh\_Cycle}}{\text{Number\_Of\_Rows\_To\_Refresh} \times T\_BRG \times MPTPR \times \text{Number\_Of\_Banks}}$$

Where:

- PTA - Periodic Timer A filed in MAMR. The value of the 2'nd divider.
- Refresh\_Period is the time (usually in msec) required to refresh a dram bank
- Number\_Of\_Beats\_Per\_Refresh\_Cycle: using the UPM looping capability, it is possible to perform more than one refresh cycle per refresh burst (in fact upto 16).
- Number\_Of\_Rows\_To\_Refresh: the number of rows in a dram bank
- T\_BRG: the cycle time of the BRG clock
- MPTPR: the value of the periodic timer prescaler (2 to 64)
- Number\_Of\_Banks: number of dram banks to refresh.

If we take for example a MCM36200 SIMM which has the following data:

- Refresh\_Period == 16 msec
- Number\_Of\_Beats\_Per\_Refresh\_Cycle: on the ADS it is 4.
- Number\_Of\_Rows\_To\_Refresh == 1024
- T\_BRG == 40 nsec (1/2 system clock @ 50 Mhz)
- MPTPR arbitrarily chosen to be 8
- Number\_Of\_Banks == 2 for that SIMM

If we assign the figures to the PTA formula we get the value of PTA should be 97 decimal or 61 hex.

The programming of the appropriate registers and UPM's memory, controlling this function, is shown in 3•4•1 "Memory Controller Registers Programming" on page 21.

**Functional Description**

**4•7•4 Variable Bus-Width Control**

Since a port's width determines its address connections, i.e., the number of address lines required for byte-selection varies (1 for 16-bit port and 2 for 32-bit port) according to the port's width, it is necessary to change address connections to a memory port if its width is to be changed. E.g.: if a certain memory is initially configured as a 32-bit port, the list significant address line which is connected to that memory's A0 line should be the MPC's ADD29. Now, if that port is to be reconfigured as a 16-bit port, the LS address line becomes ADD30.

If a linear<sup>A</sup> address scheme is to be maintained, all address lines connected to that memory are to be shifted one bit, this obviously involves extensive multiplexing (passive or active). If linear addressing scheme is not a must, than only minimal multiplexing is required to support variable port width.

In TABLE 4-3. "DRAM ADDRESS CONNECTIONS" below, the MPCADS's address connection scheme is presented:

**TABLE 4-3. DRAM ADDRESS CONNECTIONS**

Width	32 - Bit		16 - Bit	
	Depth		Depth	
Dram ADD	4 M	1 M	4 M	1 M
A0	BA29	BA29	BA29	BA29
A1	BA28	BA28	BA28	BA28
A2	BA27	BA27	BA27	BA27
A3	BA26	BA26	BA26	BA26
A4	BA25	BA25	BA25	BA25
A5	BA24	BA24	BA24	BA24
A6	BA23	BA23	BA23	BA23
A7	BA22	BA22	BA22	BA22
A8	BA21	BA21	BA21	BA21
A9	BA20	BA20	BA20	BA30
A10	BA19		BA30	

As can be seen from the table above, most of the address lines remain fixed while only 2 lines (the shaded cells) need switching. The switching scheme is shown in FIGURE 4-2 "DRAM Address Lines' Switching" on page 42. The switches on that figure are implemented by active multiplexers controlled by the BCSR1/Dram\_Half\_Word\* bit.

A. Consequent addresses lead to adjacent memory cells

Freescale Semiconductor, Inc.

**Functional Description**

**FIGURE 4-2 DRAM Address Lines' Switching**

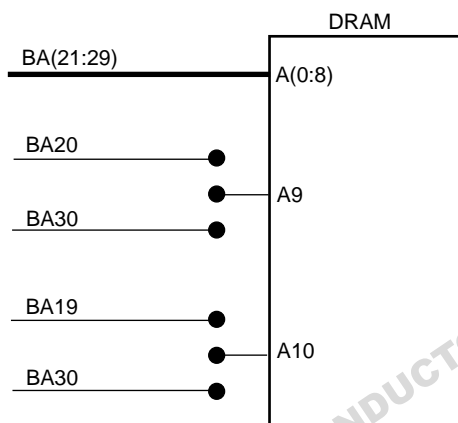

**4•8 Flash Memory**

The MPC821ADS support Flash non-volatile memory SIMMs of the following types: MCM29F020, MCM29F040 and MCM29F080, volume of which is 2Mbytes, 4Mbytes and 8Mbytes correspondingly. These devices are internally composed of 1, 2 or 4 banks of 4 Am29F040 devices. The flash SIMM (U15) resides on an 80 pin SIMM socket. Also supported are SMART's SM732A1000A 4Mbytes (1Meg X 32) or SM732A2000 (2 X 1Meg X 32).

To minimize use of MPC's chip-select lines, only one chip-select line (CS0~) is used to select the flash as a whole, while distributing chip-select lines among the internal banks is done via on-board programmable logic, according to the Presence-Detect lines of the Flash SIMM inserted to the ADS.

**FIGURE 4-3 Flash Memory SIMM Architecture**

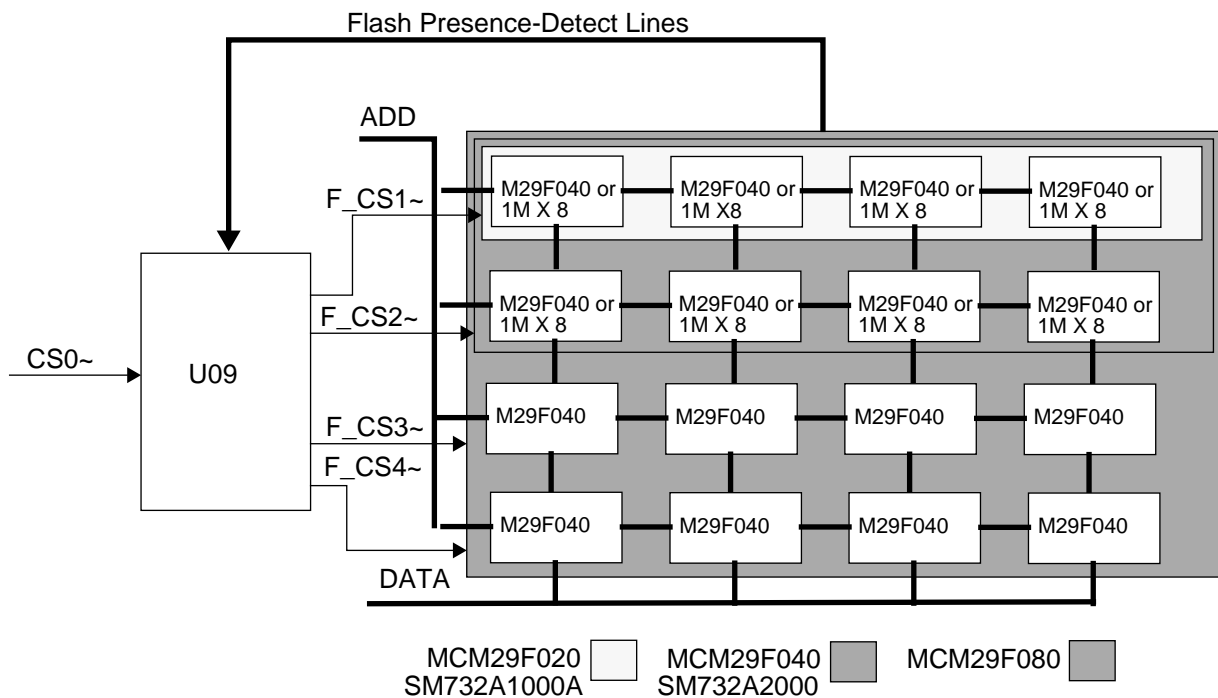

The access time of the Flash memory supplied with the ADS is 120 nsec, however, 90 nsec devices may

Freescale Semiconductor, Inc.



### Functional Description

be used. Reading the delay section of the Flash SIMM Presence-Detect lines, the debugger establishes (via OR0) the correct number of wait-states (considering 50MHz system clock frequency).

The Motorola parts which are built of MC29F0X0 devices are 5V programmable, i.e., there is no need for external programming voltage and the flash may be written almost<sup>A</sup> as a regular memory.

The SMART parts however, require 12V ± 0.5% programming voltage to be applied. If on-boards programming of such device is required, a 12V supply needs to be connected to the ADS. See 2•4•5 "P8: +12V Power Supply Connection" on page 14.

The control over the flash is done using the GPCM and a dedicated CS0~ region, controlling the whole bank. During hard - reset initializations, the debugger reads the Flash Presence-Detect lines via BCSR2 and decided how to program BR0 & OR0 in which the size and the delay of the region are determined.

The performance of the flash memory is shown in TABLE 4-4. "Flash Memory Performance Figures" below:

**TABLE 4-4. Flash Memory Performance Figures**

System Clock Frequency [MHz]	Number of System Clock Cycles			
	50		25	
Flash Delay [nsec]	90	120	90	120
Read / Write <sup>a</sup> Access [Clocks]	8	10	4	5

a. The figures in the table refer to the actual write access. The write operation continues internally and the device has to be polled for completion.

The programming of the associated registers is shown in 3•4•1 "Memory Controller Registers Programming" on page 21.

The Flash module may disabled / enabled at any time by writing '1' / '0' the FlashEn~ bit in BCSR1.

### 4•9 Ethernet Port

An Ethernet port with T.P. (10-Base-T) I/F is provided on the MPC821ADS. This port resides over SCC1of the MPC. Use is done with Motorola's MC68160 EEST (Enhanced Ethernet Serial Transceiver) to mediate between the SCC and the Ethernet medium.

To allow external use of SCC1, its pins appear at the expansion connectors and the ethernet transceiver may be Disabled / Enabled at any time by writing '1' / '0' to the EthEn~ bit in BCSR1.

The EEST is configured constantly to Twisted Pair I/F with automatic polarity correction enabled.

There are few control lines which control the EEST function and are driven by MPC's parallel I/O lines:

- 1) TPSQEL~ - Twisted Pair Signal Quality Error Test Enable. This active-low signal enables testing of the internal TP collision detect circuitry after each transmit to the TP media. It is connected to PC6<sup>B</sup> of the MPC and should be driven to '1' during normal operation.

A. A manufacturer specific dedicated programming algorithm should be implemented during flash programming.

B. After Hard reset this line wakes-up as Tri-state. For proper operation it should be initialized as Output.

### Functional Description

- 2) TPFLDL~ - Twisted Pair Full Duplex Mode Select. This active low signal allows simultaneous transmit and receive over the twisted pair lines without indicated collision. This signal is connected to PC5<sup>A</sup> of the MPC and should be driven to '0' during normal operation.
- 3) ETHLOOP - Diagnostic Loopback. This active high signal puts the EEST in diagnostic loopback mode, regardless of the I/F type it is configured to. This line is connected to PC4<sup>A</sup> of the MPC and should be driven to '0' during normal operation.

For additional information on the EEST refer to the "MC68160 Technical Data" document.

#### 4•10 Infra - Red Port

An infra-red communication port is provided with the MPCADS - the Temic's TFDS 3000 integrated transceiver, which incorporates both the receiver and transmitter optical devices with the translating logic. This port resides on SCC2 of the MPC. This device conforms to the IRDA standard, which is supported by the MPC allowing for glueless connection between the TFDS3000 and the MPC.

To allow SCC2's off-board use, the infra-red transceiver may be disabled / enabled at any time, by writing '1' / '0' to the IrdEn~ bit in BCSR1.

#### 4•11 RS232 Port

To assist user's applications and to provided convenient communication channel with a host computer, an RS232 port is provided via SMC1 port. Support is given upto 19200 baud rate via an RS232 transceiver. Use is done with MC145707 transceiver which generates RS232 levels internally using a single 5V supply and is equipped with OE and shutdown mode. When the RS232EN bit in BCSR1 is asserted (low), the transceiver is enabled. When negated, the transceiver enters standby mode, in which the receiver outputs are tri-stated, enabling use of the SMC1 port off-board via the expansion connectors.

In order of saving board space, 9 pins, female D-Type connector is used, configured to be directly (via a flat cable) connected to a standard IBM-PC like RS232 connector.

**FIGURE 4-4 RS232 Serial Port Connector**

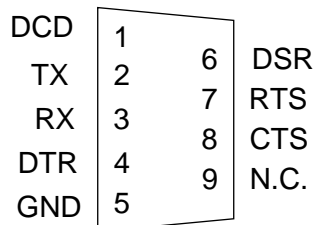

##### 4•11•1 RS-232 Port Signal Description

In the list below, the directions 'I', 'O', and 'I/O' are relative to the MPCADS board. (I.e. 'I' means input to the MPCADS)

- CD ( O ) - Data Carrier Detect. This line is always asserted by the MPCADS.
- TX ( O ) - Transmit Data.
- RX ( I ) - Receive Data.
- DTR ( I ) - Data Terminal Ready. This signal may be used by the software in the MPCADS to

## Functional Description

detect if a terminal is connected to the MPCADS board.

- DSR<sup>A</sup> ( O ) - Data Set Ready. This line is always asserted by the MPCADS.
- RTS ( I ) - Request To Send. This line is not connected on the MPCADS.
- CTS ( O ) - Clear To Send. This line is always asserted by the MPCADS.

### 4•12 PCMCIA Port

To enhance PCMCIA i/f development, a dedicated PCMCIA port is provided with the MPCADS. Support is given to 5V only PC-Cards, PCMCIA standard 2.1+ compliant. All the necessary control signals are generated by the MPC itself. To protect MPC signals from external hazards, and to provide sufficient drive capability, a set of buffers and latches is provided over address, data & strobe lines.

To conform with the design spirit of the ADS, i.e., making as much as possible MPC resources available for external application development, input buffers are provided for input control signals, controlled by the PCC\_EN~ bit in BCSR1, so the PCMCIA port may be Disabled / Enabled at any time, by writing '1' / '0' to that bit. When the PCMCIA channel is disabled, its associated pins are available off-board via the expansion connectors.

A loudspeaker (SK1) is provided on board and connected to SPKROUT line of the MPC. The speaker is buffered from the MPC and low-pass filtered. When the PCC\_EN~ bit in BCSR1 is negated (high) the speaker buffer is tri-stated so the SPKROUT signal of the MPC may be used for alternate function.

#### 4•12•1 PCMCIA Power Control

To support hot-insertion<sup>B</sup> the socket's power is controlled via a dedicated PCMCIA power controller the LTC1315 made by LINEAR TECHNOLOGY. This device, controlled by BCSR1, switches 12V VPP for card programming and controls gates of external MOSFET transistors, through which the PC Card VCC is switched.

When a card is inserted and the channel is enabled via BCSR1, i.e., both of the CD(1:2)\* (Card Detect) lines are asserted (low), the status of the voltage select lines VS(1:2)\* should be read to determine the PC Card's operation voltage level and then if the PC-Card is found to be 5V operated, the BCSR1 may be written to turn on power (5V only) to the PC Card's VCC. If a 3.3V card is inserted, power should never be switched-on.

When a card is being removed from the socket while the channel is enabled via BCSR1, the negation of CD1~ and CD2~ is sensed by the MPC and power supply to the card may be cut.

### **WARNING**

**Any application S/W handling the PCMCIA channel must check the Voltage-Sense lines before Power is applied to the PC-Card. Otherwise if power is applied to a 3.3V-Only card, permanent damage might be inflicted to the PC-Card.**

The LTC1315 may control power and VPP for 2 PC-Cards. Since there is only one PCMCIA socket on the ADS, the power control lines for the 2<sup>nd</sup> socket are used for optional 3.3V supply to the DRAM simm. When the DRMPD5 signal is connected to GND, the DRAM is powered with 3.3V VCC.

### 4•13 LCD Port

Since the I/F to the LCD is glueless, the only support given by the MPCADS for LCD display connection is a dedicated 30 pin header connector, from which a flat cable may be drawn to any kind of screen available.

---

A. Since there are only 3 RS232 transmitters available, DSR will be connected to CD.

B. I.e., card insertion when the MPCADS is powered

### **Functional Description**

All LCD (Port D) pins appear also at P10 and P13 which are the communication connectors.

It is important to remember that the levels issued by the MPC over the LCD lines are between 0 - 3.3V. Some screens have 5V CMOS compatible inputs for which 3.3V level leaves very small noise margin. For this kind of screen it is advised to use CMOS buffers with TTL compatible inputs, so that the screen gets its appropriate levels.

ARCHIVED BY FREESCALE SEMICONDUCTOR, INC.

Functional Description

FIGURE 4-5 PCMCIA Port Configuration

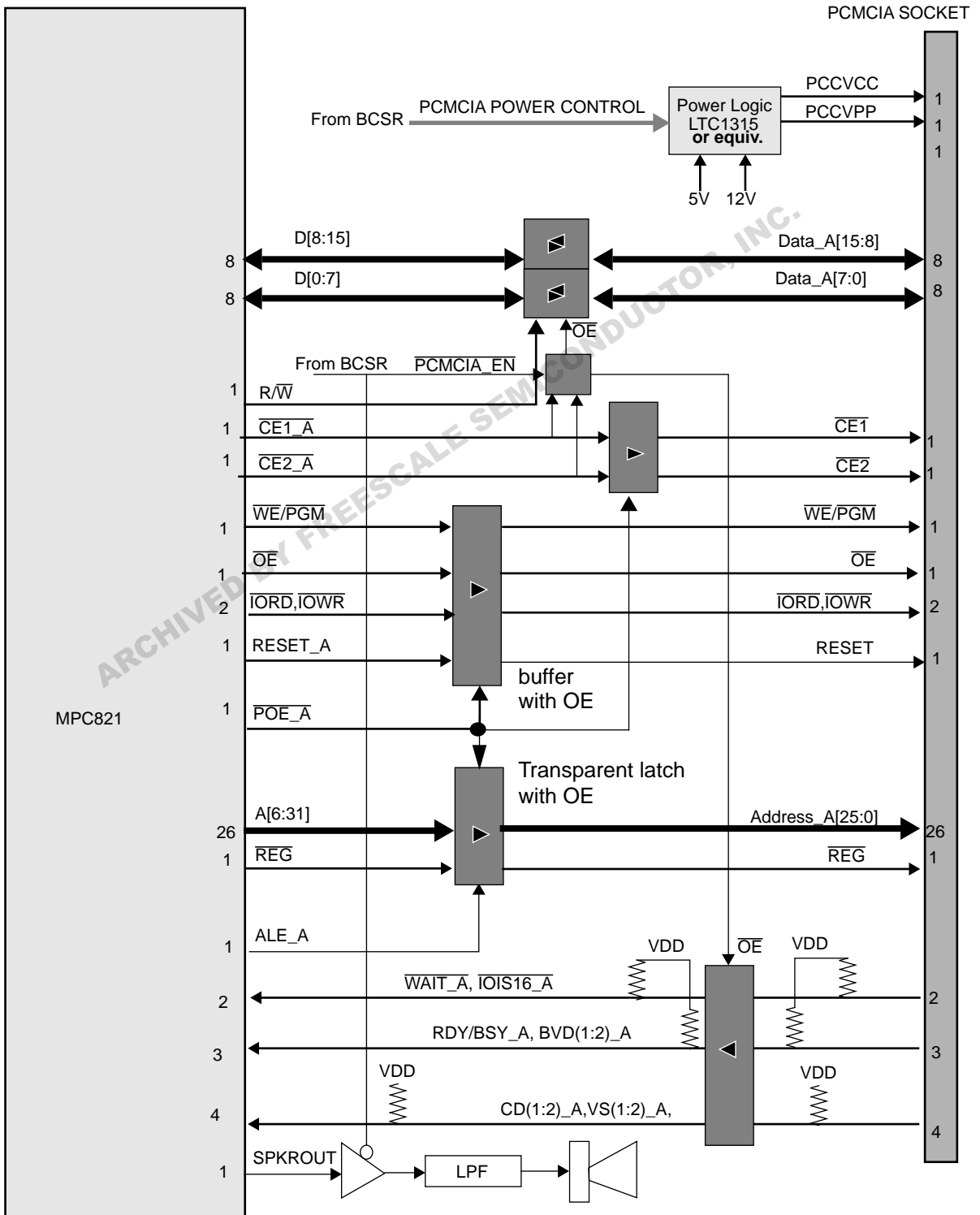

## Functional Description

### 4•14 Board Control & Status Register - BCSR

Most of the hardware options on the MPCADS are controlled or monitored by the BCSR, which is a 32<sup>A</sup> bit wide read / write register. The BCSR is accessed via the MPC's CS1 region and in fact includes 4 registers: BCSR0 to BCSR3. Since the minimum block size for a CS region is 32KBytes, BCSR0 - BCSR3 are multiply duplicated inside that region. See also 3•3 "MEMORY MAP" on page 20.

The following functions are controlled / monitored by the BCSR:

- 1) MPC's Hard Reset Configuration.
- 2) Flash Module Enable / Disable
- 3) Dram Module Enable / Disable
- 4) Dram port width - 32 bit / 16 bit.
- 5) Ethernet port Enable / Disable.
- 6) Infra-Red port Enable / Disable.
- 7) RS232 port Enable / Disable.
- 8) BCSR Enable / Disable.
- 9) Hard\_Reset Configuration Source - BCSR0 / Flash<sup>B</sup> Memory
- 10) PCMCIA control which include:
  - Channel Enable / Disable.
  - PC Card VCC appliance.
  - PC Card VPP appliance.
- 11) Dram Type / Size and Delay Identification.
- 12) Flash Size / Delay Identification.
- 13) External (off-board) tools identification or S/W option selection switch - DS2 status.

Since most of the MPCADS's modules are controlled via the BCSR and since they may be disabled in favor of external hardware, the enable signals for these modules are presented at the expansion connector, so that off-board hardware may be exclusive-or enabled with on-board modules.

#### 4•14•1 BCSR Disable Protection Logic

The BCSR itself may be disabled in favor of off-board logic. To avoid accidental disable of the BCSR, an event from which only power down recovers, a protection logic is provided:

The BCSR\_EN~ bit resides on BCSR1. This bit wakes-up active (low) during power-up and may not be changed<sup>C</sup> unless BCSR\_EN\_PROTECT~ bit in BCSR3 is written with '1' previously.

After the BCSR\_EN\_PROTECT~ is written with '1' to unprotect the BCSR\_EN~ bit there is only one shot at disabling the BCSR, since, immediately after any write to BCSR1, BCSR\_EN\_PROTECT~ is re-activated and BCSR\_EN~ is re-protected and the disabling procedure has to be repeated if desired.

#### 4•14•2 BCSR0 - Hard Reset Configuration Register

BCSR0 is located at offset 0 on BCSR space. It may be read or written at any time<sup>D</sup>. BCSR0 gets its defaults upon MAIN Power-On reset. During Hard-Reset data contained in BCSR0 is driven on the data

A. In fact only the upper 16 bits - D(0:15) are used, but the BCSR is mapped as a 32 bit wide register and should be accessed as such.

B. Provided that support is provided also within the MPC.

C. It may be written but will not be influenced.

D. Provided that BCSR is not disabled.

**Functional Description**

bus to provide the Hard-Reset configuration for the MPC, this, if the Flash\_Configuration\_Enable~ bit in BCSR1 is not active. BCSR0 may be written at any time to change the Hard-Reset configuration of the MPC. The new values will become valid when Hard-Reset is issued to the MPC regardless of the Hard-Reset source. The description of BCSR0 bits is shown in TABLE 4-5. "BCSR0 Description" on page 49.

**TABLE 4-5. BCSR0 Description**

BIT	MNEMONIC	FUNCTION	PON DEF.	ATT
0	ERB	External Arbitration. When '0' during Hard-Reset, Arbitration is performed internally. When '1' during Hard-Reset, Arbitration is performed externally.	0	R,W
1	IP	Interrupt Prefix. When '0' during Hard-Reset, Interrupt prefix set to 0xFFFF0000, if '1' Interrupt Prefix set to 0.	0	R,W
2	Reserved	Implemented <sup>a</sup>	0	R,W
3	BDIS	Boot Disable. When '0' during Hard-Reset, CS0~ region is enabled for boot. When '1', CS0~ region is disabled for boot.	0	R,W
4 - 5	BPS(0:1)	Boot Port Size. Determines the port size for CS0~ at boot. '00' - 32 bit, '01' - 8 bit, '10' - 16 bit, '11' - reserved.	'00'	R,W
6	Reserved	Implemented <sup>a</sup>	0	R,W
7 - 8	ISB(0:1)	Initial Space Base. Value during Hard-Reset determines the initial base address of the internal MPC memory map. When '00' - initial space at 0, when '01' - initial space at 0x00F00000, when '10' - initial space at 0xFF000000, when '11' - initial space at 0xFFFF0000.	'10'	R,W
9 - 10	DBGC(0:1)	Debug Pins Configuration. Value during Hard-Reset determines the function of the PCMCIA channel II pins. When '00' - these pins function as PCMCIA channel II pins, when '01' - they serve as Watch-Points, '10' - Reserved, when '11' - they become show-cycle attribute pins, e.g., VFLS, VF...	'11'	R,W
11-12	DBPC(0:1)	Debug Port Pins Configuration. Value during Hard-Reset determines the location of the debug port pins. When '00' - debug port pins are on the JTAG port, when '01' - debug port non-existent, '10' - Reserved, when '11' debug port is on PCMCIA channel II pins.	'00'	R,W
13 - 14	EBDF(0:1) <sup>b</sup>	External Bus Division Factor. Value during Hard Reset determines the factor upon which the CLKOUT of the MPC external bus, is divided with respect to its internal MPC clock. When '00' - CLKOUT is GCLK2 divided by 1, when '01', CLKOUT is GCLK2 divided by 2.	'00'	R,W
15	Reserved	Implemented <sup>a</sup> .	'0'	R,W
16 - 31	Reserved	Un-Implemented	-	-

a. May be read and written as any other fields and are presented at their associated data pins during Hard-Reset.

b. Applicable for MPC's revision A or above. Otherwise have no influence.

**4•14•3 BCSR1 - Board Control Register**

The BCSR1 serves as main control register on the MPCADS. It is accessed at offset 4 from BCSR base

### Functional Description

address. It may be read or written at any time<sup>A</sup>. BCSR1 gets its defaults upon Power-On reset. Most of BCSR1 pins are available at the expansion connectors, providing visibility towards external logic. BCSR1 fields are described in TABLE 4-6. "BCSR1 Description" on page 50.

**TABLE 4-6. BCSR1 Description**

BIT	MNEMONIC	Function	PON DEF	ATT.
0	FLASH_EN	<b>Flash Enable.</b> When this bit is active ( <b>low</b> ), the Flash memory module is enabled on the local memory map. When in-active, the Flash memory is removed from the local memory map and CS0~, to which the Flash memory is connected may be used off-board via the expansion connectors.	0	R,W
1	DRAM_EN	<b>Dram Enable.</b> When this bit is active ( <b>low</b> ), the DRAM module is enabled on the local memory map. When in-active, the DRAM is removed from the local memory map and CS2~ and CS3~ <sup>a</sup> , to which the DRAM is connected may be used off-board via the expansion connectors.	1	R,W
2	ETHEN	<b>Ethernet Port Enable.</b> When asserted ( <b>low</b> ) the EEST connected to SCC1 is enabled. When negated (high) that EEST is in standby mode, while all its system i/f signals are tri-stated.	1	R,W
3	IRDEN	<b>Infra-Red Port Enable.</b> When asserted ( <b>low</b> ), the Infra-Red transceiver, connected to SCC2 is enabled. When negated, the Infra-Red transceiver is put in shutdown mode. And SCC2 pins are available for off-board use via the expansion connectors.	1	R,W
4	FLASH_CFG_EN	<b>Flash Configuration Enable.</b> When this bit is asserted ( <b>low</b> ): (A) - the Hard-Reset configuration held in BCSR0 is NOT driven on the data bus during Hard-Reset and (B) - configuration data held at the 1'st word of the flash memory is driven to the data bus during Hard-Reset. <sup>b</sup>	1	R,W
5	CNT_REG_EN_P ROTECT	<b>Control Register Enable Protect.</b> When this bit is active ( <b>low</b> ) the BCSR_EN bit in that register can not be written. When in-active, BCSR_EN may be written to remove the BCSR from the memory map. After any write to BCSR1 this bit becomes active again. This bit is a read-only <sup>c</sup> bit on that register.	0	R
6	BCSR_EN	<b>BCSR Enable.</b> When this bit is active ( <b>low</b> ) the Board Control & Status Register is enabled on the local memory map. When inactive, the BCSR may not be read or written and its associated CS1~ is available for off-board use via the expansion connectors. This bit may be written with '1' only if CNT_REG_EN_PROTECT bit is negated (1). When the BCSR is disabled it still continues to configure the board according the last data held in it even during Hard-Reset.	0	R,W
7	RS232EN	<b>RS232 port Enable.</b> When asserted ( <b>low</b> ) the RS232 transceiver is enabled. When negated, the RS232 transceiver is in standby mode and SMC1 pins are available for off-board use via the expansion connectors.	1	R,W

A. Provided that BCSR is not disabled.



**Functional Description**

**TABLE 4-6. BCSR1 Description**

BIT	MNEMONIC	Function	PON DEF	ATT.
8	PCCEN	<b>PC Card Enable.</b> When asserted ( <b>low</b> ), the on-board PCMCIA channel is enabled, i.e., address and strobe buffers are enabled to / from the card. When negated, all buffers to / from the PCMCIA channel are disabled allowing off-board use of its associated lines.	1	R,W
9	PCCVCCON	<b>Pc Card VCC ON.</b> When this bit is active ( <b>low</b> ), 5V supply is applied to the PCMCIA socket. When inactive, VCC to the PCMCIA channel is tri-stated.	1	R,W
10 - 11	PCCVPP(0:1)	<b>PC Card VPP.</b> These signals determine the voltage applied to the PCMCIA card's VPP. Possible values are 0 / 5 / 12 V. For the encoding of these lines and their associated voltages see TABLE 4-7. "PCCVPP(0:1) Assignment" on page 51.	1	R,W
12	Dram_Half_Word	<b>Dram Half Word.</b> When this bit is active ( <b>low</b> ) and the steps listed in 4•7•1 "DRAM 16 Bit Operation" on page 38, are taken, the DRAM becomes 16 bit wide. When inactive the DRAM is 32 bit wide.	1	R,W
13 - 31	Reserved	Un-implemented	-	-

- a. In case a Single Bank DRAM SIMM is used CS3~ is free as well.
- b. Provided that this option is supported by the MPC by driving address lines low and asserting CS0~ during Hard-Reset.
- c. It is written in BCSR3.

**TABLE 4-7. PCCVPP(0:1) Assignment**

PCCVPP(0:1)	PC Card VPP [V]
00	0
01	5
10	12 <sup>a</sup>
11	Hi-Z

- a. Provided that a 12V power supply is applied.

**4•14•4 BCSR2 - Board Status Register - 1**

BCSR2 is a status register which is accessed at offset 8 from the BCSR base address. Its a read only register which may be read at any time<sup>A</sup>. BCSR2's various fields are described in TABLE 4-8. "BCSR2 De-

A. Provided that BCSR is not disabled.

**Functional Description**

scription" on page 52.

**TABLE 4-8. BCSR2 Description**

BIT	MNEMONIC	Function	PON DEF	ATT.
0 - 3	FLASH_PD(4:1)	<b>Flash Presence Detect(4:1).</b> These lines are connected to the Flash SIMM presence detect lines which encode the type of Flash SIMM mounted on the Flash SIMM socket - U15. There are additional 3 presence detect lines which encode the SIMM's delay but appear in BCSR3. For the encoding of FLASH_PD(4:1) see TABLE 4-9. "Flash Presence Detect (4:1) Encoding" on page 52.	-	R
4	DRAM_EDO	<b>Dram Is EDO.</b> When this bit is active ( <b>low</b> ) it indicates that the DRAM SIMM is capable of EDO burst read. When inactive, the DRAM SIMM is regular.	-	R
5 - 8	DRAM_PD(4:1)	<b>Dram Presence Detect.</b> These lines are connected to the DRAM SIMM presence detect lines which encode the size and the delay of the DRAM SIMM mounted on the DRAM SIMM socket - U15. For the encoding of DRAM_PD(4:1) see TABLE 4-10. "DRAM Presence Detect (2:1) Encoding" on page 53 and TABLE 4-11. "DRAM Presence Detect (4:3) Encoding" on page 53.	-	R
9 - 12	EXTTOLI(0:3)	<b>External Tools Identification.</b> These lines, which are available at the expansion connectors are intended to serve as tools' identifier or as S/W option selection. On board s/w may check these lines to detect the presence of various tools (h/w expansions) at the expansion connectors or the state of DS2 (see FIGURE 3-1 "DS2 - Description" on page 17) or a combination of both. Half of the available combinations are reserved while the other half is available to users' applications. For the external tools' codes and their associated combinations see TABLE 4-12. "EXTTOOLI(0:3) Assignment" on page 53.	-	R
13 - 31	Reserved	Un-implemented.		

**TABLE 4-9. Flash Presence Detect (4:1) Encoding**

FLASH_PD(4:1)	FLASH TYPE / SIZE
0 - 5	Reserved
6	MCM29080 - 8 MByte SIMM, by Motorola
7	MCM29040 - 4 MByte SIMM, by Motorola
8	MCM29020 - 2 MByte SIMM, by Motorola
9	Reserved
A	SM732A1000A - 4 Mbyte SIMM, by SMART Modular Technologies.
B	SM732A2000 - 8Mbyte SIMM, by SMART Modular Technologies.
C - F	Reserved.

**Functional Description**

**TABLE 4-10. DRAM Presence Detect (2:1) Encoding**

DRAM_PD(2:1)	DRAM TYPE / SIZE
00	MCM36100 by Motorola or MT8D132X by Micron- 4 MByte SIMM
01	MCM36800 by Motorola or MT16D832X by Micron - 32 MByte SIMM
10	MCM36400 by Motorola or MT8D432X by Micron - 16 MByte SIMM
11	MCM36200 by Motorola or MT16D832X by Micron - 8 MByte SIMM

**TABLE 4-11. DRAM Presence Detect (4:3) Encoding**

DRAM_PD(4:3)	DRAM DELAY
00	Reserved
01	Reserved
10	70 nsec
11	60 nsec

**TABLE 4-12. EXTTOOL(0:3) Assignment**

EXTTOOL(0:3)	External Tool
0000-0111	Reserved
1000-1110	User Available
1111	Non Existent

**WARNING**

Since EXTOLI(0:3) lines may be DRIVEN LOW ('0') by DS2, OFF-BOARD tools should NEVER DRIVE them HIGH. Failure in doing so, might result in PERMANENT DAMAGE to the ADS and / or to OFF-BOARD logic.

**4•14•5 BCSR3 - Auxiliary Control / Status Register**

BCSR3 is an additional control / status register which may be accessed at offset 0xC from BCSR base address. BCSR3 gets its defaults during Power-On reset and may be read or written at any time. The de-

**Functional Description**

scription of BCSR3 is shown in TABLE 4-13. "BCSR3 Description" on page 54.

**TABLE 4-13. BCSR3 Description**

BIT	MNEMONIC	Function	PON DEF	ATT.
0 - 4	Reserved	Un-Implemented	-	-
5	CNT_REG_EN_P ROTECT	<b>Control Register Enable Protect.</b> When this bit is active ( <b>low</b> ) the BCSR_EN bit in that register can not be written. When in-active, BCSR_EN may be written to remove the BCSR from the memory map. After any write to BCSR1 this bit becomes active again. This bit is a write-only bit on that register.	0	W
6 - 7	Reserved	Un-Implemented	-	-
8	BREVN0	<b>Board Revision Number 0.</b> This is the MS bit of the Board Revision Number. See TABLE 4-14. "MPC821/860ADS Revision Number Conversion Table" on page 54, for the interpretation of the Board Revision Number.	-	R
9 - 11	FLASH_PD(7:5)	<b>Flash Presence Detect(7:5).</b> These lines are connected to the Flash SIMM presence detect lines which encode the Delay of Flash SIMM mounted on the Flash SIMM socket - U15. There are additional 4 presence detect lines which encode the SIMM's Type but appear in BCSR2. For the encoding of FLASH_PD(7:5) see TABLE 4-15. "FLASH Presence Detect (7:5) Encoding" on page 55.		
12	BREVN1	<b>Board Revision Number 1.</b> Second bit of the Board Revision Number. See TABLE 4-14. "MPC821/860ADS Revision Number Conversion Table" on page 54, for the interpretation of the Board Revision Number.	-	R
13	Reserved	Un-Implemented		
14 - 15	BREVN(2:3)	<b>Board Revision Number (2:3).</b> The 2 LS bits of the Board Revision Number. See TABLE 4-14. "MPC821/860ADS Revision Number Conversion Table" on page 54, for the interpretation of the Board Revision Number.	-	R

**TABLE 4-14. MPC821ADS Revision Number Conversion Table**

Revision Number (0:3) [Hex]	MPC821ADS Revision
0	ENG (Engineering)
1	PILOT
2	A
3 - F	Reserved

**Functional Description**

**TABLE 4-15. FLASH Presence Detect (7:5) Encoding**

FLASH_PD(7:5)	Flash Delay [nsec]
000 - 001	Not Supported
010	120 (Motorola's SIMMs)
011	90 (Motorola's SIMMs)
100	90 (SMART's SIMMs)
101	120 (SMART's SIMMs)
110	150 (SMART's SIMMs)
111	Not Supported

ARCHIVED BY FREESCALE SEMICONDUCTOR, INC.

**Functional Description**

**4•15 Debug Port Controller**

The debug port of the MPC821ADS is implemented on-board, connected to the MPC via the JTAG<sup>A</sup> port. Since the location of the debug port is determined via the Hard-Reset configuration, It is important that the relevant configuration bits (see 4•2•6 "Reset Configuration" on page 35) are not changed, if working with the local debug port is desired.

The debug port controller is interfaced to host computer via Motorola's ADI<sup>B</sup> port, which is an 8-bit wide parallel port. Since the debug port is serial, conversion is done by hardware between the parallel and serial protocols.

The debug port is configured at SOFT-Reset to "Asynchronous Clock Mode" i.e., the debug port drives the debug clock - DSCK, which may be asynchronous with the MPC system clock.

**FIGURE 4-6 Debug Port Controller Block Diagram**

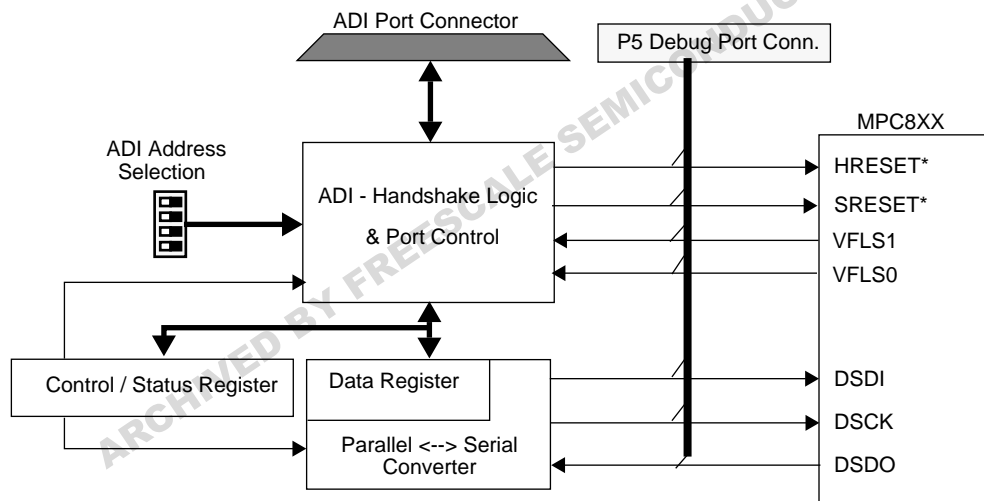

To allow for an external debug port controller to be incorporated with the MPCADS and to allow target system debug by the ADS, a standard 10 pin, debug port connector (P5) is provided and the local debug port controller may be disabled by removing the ADI bundle from the its connector - P1.

When the ADI's 37 lead cable is disconnected from either the ADI connector or from the MPCADS's 37 pin connector, the debug port controller is disabled allowing either the connection of an external debug port controller, or independent s/w run, i.e., the MPC boots from the flash memory to run user's application without debug port controller intervention. This feature becomes especially handy regarding demo's.

The ADI I/F supports upto 8 boards connected on the same bundle. Address selection is done via DS1. See 2•3•1 "ADI Port Address Selection" on page 9.

The debug port I/F has two registers: a control / status register and a data register. The control / status register hold I/F related control / status functions, while the data register serves as the parallel side of the Transmit / Receive shift register.

The control / status register is accessed when D\_C~ bit is low while the data register is accessed when D\_C~ is driven high by the host via the ADI port. See APPENDIX B - "ADI I/F" on page 174.

**4•15•1 MPC821ADS As Debug Port Controller For Target System**

The MPCADS may be used as a debug port controller for a target system, provided that the target system

A. The debug port location is determined by the HARD - Reset configuration.

B. See APPENDIX B - "ADI I/F" on page 174 for further information.

### Functional Description

has a 10 pin header connector matching P5. (See TABLE 5-5. "P5 - Interconnect Signals" on page 67).

#### **WARNING**

**When connecting the ADS to a target system via P5 and a 10 lead flat-cable, the MPC MUST be REMOVED from its SOCKET (U18). Otherwise, PERMANENT DAMAGE might be inflicted to either the local MPC or to the Target MPC.**

In this mode of operation, the on-board debug port controller, is connected to the target system's debug-port connector (see 4•15•1•1 "Debug Port Connection - Target System Requirements" below). Since DSDO signal is driven by the MPC, it is a must to remove the local MPC from its socket, to avoid contention over this line.

When the local MPC is removed from its socket, all ADS's modules are inaccessible, except for the debug-port controller. All module-enable indications are darkened, regardless of their associated enable bits in the BCSR. Pull-up resistor are connected to Chip-Select lines, so they do not float when the MPC is removed from its socket, avoiding possible contention over data-bus lines.

#### **4•15•1•1 Debug Port Connection - Target System Requirements**

In order for a target system may be connected to the ADS, as a debug port controller, few measures need to be taken on the target system:

- 1) A 10-pin header connector should be made available, with electrical connections matching TABLE 5-5. "P5 - Interconnect Signals" on page 67.
- 2) Pull-down resistors, of app. 2KΩ should be connected over DSDI<sup>A</sup> and DSCK<sup>A</sup> signals. These resistors are to provide normal<sup>B</sup> operation, when a debug-port controller, is not connected to the target system
- 3) The debug-port should be enabled and routed to the desired pins. See the DBGC and DBPC fields within the HARD-RESET configuration word.

#### **4•15•2 Debug Port Control / Status Register**

The control / status register is an 8 bit register (bit 7 stands for MSB). For the description of the ADI control status register see TABLE 4-16. "Debug Port Control / Status Register" on page 57.

**TABLE 4-16. Debug Port Control / Status Register**

BIT	MNEMONIC	Function	I/F Res et DEF	ATT.
7	MpcRst	<b>Mpc Reset.</b> When this status only bit indicates when active ( <b>high</b> ) that either a SOFT or a HARD reset is driven by the MPC.	-	R
6	TxError	<b>Transmit Error.</b> When this status only bit is active ( <b>high</b> ) it indicates that the last transmission towards the MPC, was cut by an internal PDA reset source. This bit is updated for each byte sent.	-	R
5	InDebug	<b>In Debug Mode.</b> When this status only bit is active ( <b>high</b> ) it indicates that the MPC is in debug mode <sup>a</sup> .	-	R

A. Remember that the location of DSDI and DSCK is determined by the HARD-Reset configuration.

B. Normal - i.e., boot via CS0~.

**Functional Description**

**TABLE 4-16. Debug Port Control / Status Register**

BIT	MNEMONIC	Function	I/F Res et DEF	ATT.
4 - 3	Reserved	Should be always written with '00'.	'00'	R/W
2	StatusRequest	<b>Status Request.</b> When the host writes this bit active ( <b>low</b> ), the I/F will issue a status read request to the host by asserting ADS_REQ line to the host. When the host writes the control register with this bit negated, no status read request is issued. Upon I/F reset this bit wakes-up active.	0	R/W
1	DiagLoopBack	<b>Diagnostic Loopback Mode.</b> When this control bit is active ( <b>low</b> ) the I/F is placed in Diagnostic Loopback Mode. I.e., DSDI is connected internally to DSDO, DSDI is tri-stated, and each data byte sent to the I/F data register, is sampled back into the receive shift register. Using this bit allows to check the I/F upto transmit and receive shift registers. Upon I/F reset this bit wakes-up active.	0	R/W
0	DebugEntry	<b>Debug Mode Entry.</b> When this bit is active ( <b>low</b> ), the MPC will enter debug mode instantly after SOFT reset. When inactive, the MPC will start executing normally and will enter debug mode only after exception. Upon I/F reset this bit wakes-up active.	0	R/W

a. Provided that the PCMCIA channel II pins are configured as debug pins - i.e, VFLS(0:1) signals are available. If not, the debug port can not be operated correctly.

**FIGURE 4-7 Standard Debug Port Connector**

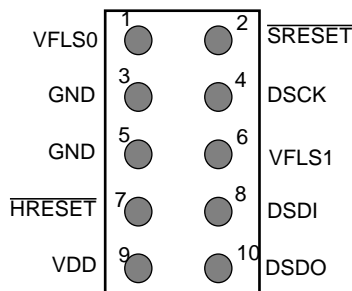

**4•15•3 Standard MPCXXX Debug Port Connector Pin Description**

The pins on the standard debug port connector are the maximal group needed to support debug port controllers for both the MPC5XX and MPC8XX families. Some of the pins are redundant for the MPC8XX family but are necessary for the MPC5XX family.

**4•15•3•1 VFLS(0:1)**

These pins indicate to the debug port controller whether or not the MPC is in debug mode. When both VFLS(0:1) are at '1', the MPC is in debug mode. These pins may serve alternate functions with the MPC but are needed for proper debug port operation.

**4•15•3•2 HRESET\***

This is the Hard-Reset bidirectional signal of the MPC. When this signal is asserted (low) the MPC enters hard reset sequence which include hard reset configuration. This signal is made redundant with the MPC8XX debug port controller since there is a hard-reset command integrated within the debug port pro-



## Functional Description

to col. However, the local debug port controller uses this signal for compatibility with MPC5XX existing boards and s/w.

### 4•15•3•3 SRESET\*

This is the Soft-Reset bidirectional signal of the MPC8XX. On the MPC5XX it is an output. The debug port configuration is sampled and determined on the rising-edge<sup>A</sup> of SRESET\* (for both processor families). On the MPC8XX it is a bidirectional signal which may be driven externally to generate soft reset sequence. This signal is in fact redundant regarding the MPC8XX debug port controller since there is a soft-reset command integrated within the debug port protocol. However, the local debug port controller uses this signal for compatibility with MPC5XX existing boards and s/w.

### 4•15•3•4 DSDI - Debug-port Serial Data In

Via the DSDI signal, the debug port controller sends its data to the MPC. The DSDI serves also a role during soft-reset configuration. (See 4•2•6•3 "Soft Reset Configuration" on page 36).

### 4•15•3•5 DSCK - Debug-port Serial Clock

During asynchronous clock mode, the serial data is clocked into the MPC according<sup>B</sup> to the DSCK clock. The DSCK serves also a role during soft-reset configuration. (See 4•2•6•3 "Soft Reset Configuration" on page 36).

### 4•15•3•6 DSDO - Debug-port Serial Data Out

DSDO is clocked out by the MPC according to the debug port clock, in parallel<sup>C</sup> with the DSDI being clocked in. The DSDO serves also as "READY" signal for the debug port controller to indicate that the debug port is ready to receive controller's command (or data).

## 4•16 Power

There are 4 power buses with the MPC:

- 1) I/O
- 2) Internal Logic
- 3) Keep Alive
- 4) PLL

and there are 4 power buses on the MPCADS:

- 1) 5V bus
- 2) 3.3V bus
- 3) 2.0V bus
- 4) 12V bus

---

A. In fact that configuration is divided into 2 parts, the first is sampled 3 system clock cycles prior to the rising edge of SRESET\* and the second is sampled 8 clocks after that edge.

B. I.e., DSDI must meet setup / hold time to / from rising edge of the DSCK.

C. I.e., full-duplex communication.

Functional Description

FIGURE 4-8 MPC821ADS Power Scheme

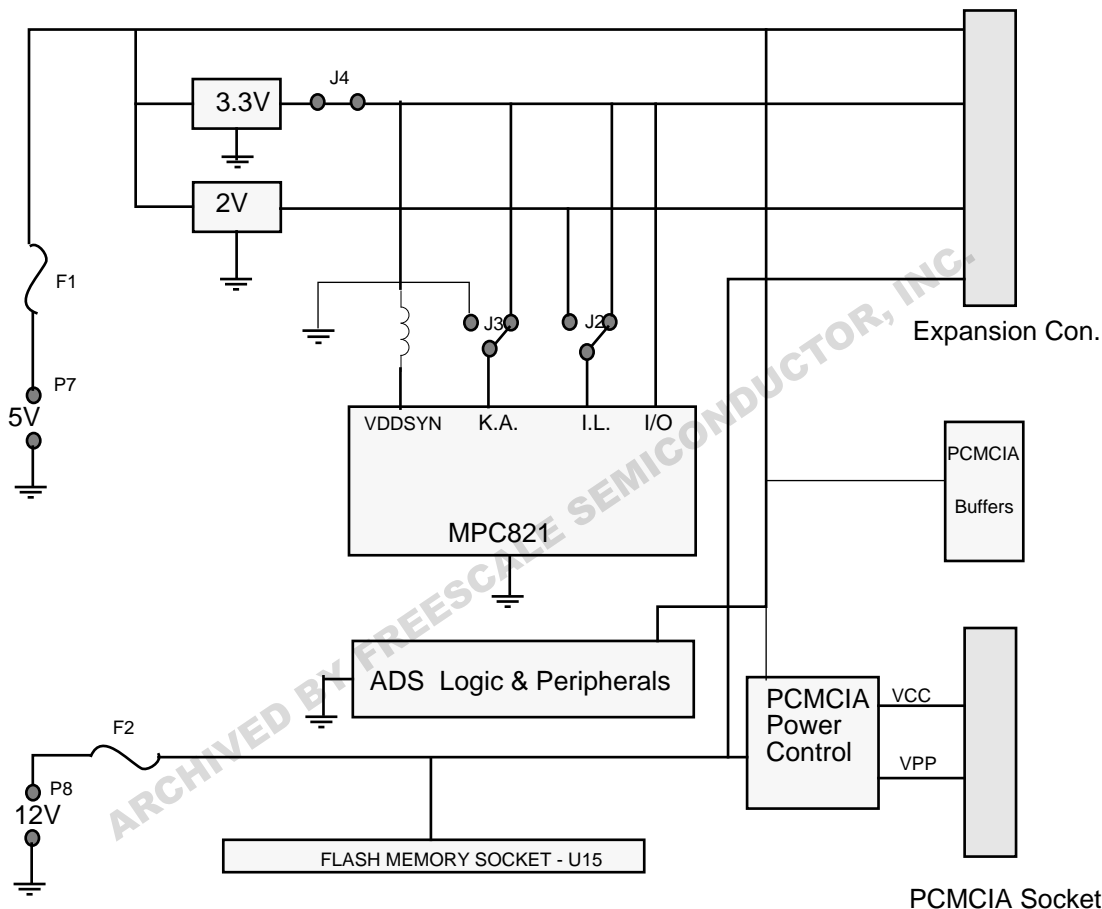

To support off-board application development, the power buses are connected to the expansion connectors, so that external logic may be powered directly from the board. The maximum current allowed to be drawn from the board's various power buses is as follows:

TABLE 4-17. Off-board Application Maximum Current Consumption

Power BUS	Current
5V	2A
3.3V	0A
2V	0.5A
12V	100 mA.

To protect on board devices against supply spikes, decoupling capacitors (typically 0.1 $\mu$ F) are provided between the devices' power leads and GND, located as close as possible to the power leads.

Special care is taken for PLL power leads, which has isolated "clean" ground and filtered VDD.

## Functional Description

### 4•16•1 5V Bus

All of the MPCADS peripherals reside on the 5V bus. Since the MPC is 5V friendly, it may operate with 5V levels on its lines with no damage. The 5V bus is connected to an external power connector via a fuse F1 of 5A fast-blow.

To protect against reverse-voltage or over-voltage being applied to the 5V inputs a set of high-current diodes and zener diode are connected between the 5V bus GND. When either over or reverse voltage is applied to the MPCADS, the protection logic will blow the fuse, while limiting the momentary effects on board.

### 4•16•2 3.3V Bus

The MPC itself is powered by the 3.3<sup>A</sup> bus, which is produced from the 5V bus using a special low-voltage drop, linear voltage regulator made by Linear Technology, the LT1086 which is capable of driving upto 1.5A. Since the local 3.3V current consumption might be around 1.5A, no power should be drawn from the 3.3V bus via the expansion connectors.

### 4•16•3 2V Bus

To support evaluation of the MPC operating with two supply levels, i.e., internal logic is powered with 2V and the I/O is powered with 3.3 - a dedicated 2V voltage regulator (LM317) is provided. That regulator is also powered by the 5V bus.

The internal logic's VDD may be switched between the 3.3V bus and the 2V bus, by means of a fabricated jumper.

### 4•16•4 12V Bus

The sole purpose of the 12V bus is to supply VPP (programming voltage) for the PCMCIA card and / or to a FLASH memory residing on U15. It is connected from a dedicated input connector - P8, via a fuse - F2 (1A fast-blow) and protected from over / reverse voltage application by means of Zener diode and high-current diodes.

If the PCMCIA channel is not used or if a card which doesn't require a 12V VPP is being used or the flash memory available on-board does not require 12V for programming or both of them do not require programming, the 12V input to the MPCADS may be omitted.

### 4•16•5 Keep Alive Power

The reason for the existence of the KAPWR bus is to allow current measurements over that bus and to allow the connection of an external power source to the KAPWR input of the MPC. As seen in FIGURE 4-8 "MPC821/860ADS Power Scheme" on page 60, it is possible to connect an external power source to the KAPWR rail. This can be done by removing the fabricated jumper from J3 and connected an external power source between J3/2 and J3/3.

---

A. At full speed. When lower performance is needed the internal logic may be powered from the 2V bus.

**Support Information**

**5 - Support Information**

In this chapter all information needed for support, maintenance and connectivity to the MPC821ADS is provided.

**5•1 Interconnect Signals**

The MPC821ADS interconnects with external devices via the following set of connectors:

- 1) P1 - ADI Port connector
- 2) P2 - Ethernet port
- 3) P3 - RS232 port
- 4) P4 - PCMCIA port
- 5) P5 - External Debug port controller input
- 6) P6, P9, P10 & P12 - Expansion & Logic Analyzer connection
- 7) P7 - 5V Power In
- 8) P8 - 12V Power In
- 9) P11 - LCD port
- 10) P13 - Serial Expansion connector

**5•1•1 P1 ADI - Port Connector**

The ADI port connector - P1, is a 37-pin, Male, 90°, D-Type connector, signals of which are described in TABLE 5-1 "P1 - ADI Port Interconnect Signals" below:

**TABLE 5-1 P1 - ADI Port Interconnect Signals**

Pin No.	Signal Name	Description
1		Not connected with this application
2	D_C~	Data / Control selection. When '1', the debug port controller's data register is accessed, when '0' the debug port controller's control register is accessed.
3	HST_ACK	Host Acknowledge input signal from the host.
4	ADS_SRESET	When asserted ('1') and the ads is selected by the host, generates Soft Reset to the MPC.
5	ADS_HRESET	When asserted ('1') and the ads is selected by the host, generates Hard Reset to the MPC.
6	ADS_SEL2	ADI I/F address line 2 (MSB).
7	ADS_SEL1	ADI I/F address line 1.
8	ADS_SEL0	ADI I/F address line 0 (LSB).
9	HOST_REQ	HOST Request input signal from the host
10	ADS_REQ	ADS Request output signal from the MPC821ADS to the host
11	ADS_ACK	ADS Acknowledge output signal from the MPC821ADS to the host
12		Not connected with this application
13		Not connected with this application
14		Not connected with this application
15		Not connected with this application
16	PD1	Bit 1 of the ADI port data bus
17	PD3	Bit 3 of the ADI port data bus

**Support Information**

**TABLE 5-1 P1 - ADI Port Interconnect Signals**

Pin No.	Signal Name	Description
18	PD5	Bit 5 of the ADI port data bus
19	PD7	Bit 7 of the ADI port data bus
20 - 25	GND	Ground.
26		Not connected with this application
27 - 29	HOST_VCC	HOST VCC input from the host. Used to qualify ADS selection by the host. When host is off, the debug port controller is disabled.
30	HOST_ENABLE~	HOST Enable input signal from the host. (Active low). Indicates that the host computer is connected to ADS. Used, in conjunction with HOST_VCC and ADS_SEL(2:0) to qualify ADS selection by the host.
31 - 33	GND	Ground.
34	PD0	Bit 0 of the ADI port data bus
35	PD2	Bit 2 of the ADI port data bus
36	PD4	Bit 4 of the ADI port data bus
37	PD6	Bit 6 of the ADI port data bus

**5•1•2 P2 - Ethernet Port Connector**

The Ethernet connector on the MPCADS - P2, is a Twisted-Pair (10-Base-T) compatible connector. Use is done with 90°, 8-pin, RJ45 connector, signals of which are described in TABLE 5-1.

**TABLE 5-2 P2 - Ethernet Port Interconnect Signals**

Pin No.	Signal Name	Description
1	TPTX	Twisted-Pair Transmit Data positive output from the MPC821ADS.
2	TPTX~	Twisted-Pair Transmit Data negative output from the MPC821ADS.
3	TPRX	Twisted-Pair Receive Data positive input to the MPC821ADS.
4	-	Not connected
5	-	Not connected
6	TPRX~	Twisted-Pair Receive Data negative input to the MPC821ADS.
7	-	Not connected
8	-	Not connected

**5•1•3 P3 - RS232 Port Connector**

The RS232 port connector - P3, is a 9 pin, 90°, female D-Type connector, signals of which are presented in TABLE 5-1.

**TABLE 5-3 P3 - Interconnect Signals**

Pin No.	Signal Name	Description
1	CD	Carrier Detect <b>output</b> from the MPC821ADS.
2	TX	Transmit Data <b>output</b> from the MPC821ADS.
3	RX	Receive Data <b>input</b> to the MPC821ADS.
4	DTR	Data Terminal Ready <b>input</b> to the MPC821ADS.
5	GND	Ground signal of the MPC821ADS.
6	DSR	Data Set Ready <b>output</b> from the MPC821ADS.
7	RTS (N.C.)	Request To Send. This line is not connected in the MPC821ADS.

**Support Information**

**TABLE 5-3 P3 - Interconnect Signals**

Pin No.	Signal Name	Description
8	CTS	Clear To Send <b>output</b> from the MPC821ADS.
9	-	Not connected

**5•1•4 PCMCIA Port Connector**

The PCMCIA port connector - P4, is a 68 - pin, Male, 90°, PC Card type, signals of which are presented in TABLE 5-4.

**TABLE 5-4. P4 - PCMCIA Connector Interconnect Signals**

Pin No.	Signal Name	Attribute	Description
1	GND		Ground.
2	PCCD3	I/O	PCMCIA Data line 3.
3	PCCD4	I/O	PCMCIA Data line 4.
4	PCCD5	I/O	PCMCIA Data line 5.
5	PCCD6	I/O	PCMCIA Data line 6.
6	PCCD7	I/O	PCMCIA Data line 7.
7	BCE1A~	O	PCMCIA Chip Enable 1. Active-low. Enables EVEN numbered address bytes.
8	PCCA10	O	PCMCIA Address line 10.
9	OE~	O	PCMCIA Output Enable signal. Active-low. Enables data outputs from PC-Card during memory read cycles.
10	PCCA11	O	PCMCIA Address line 11.
11	PCCA9	O	PCMCIA Address line 9.
12	PCCA8	O	PCMCIA Address line 8.
13	PCCA13	O	PCMCIA Address line 13.
14	PCCA14	O	PCMCIA Address line 14.
15	WE~/PGM~	O	PCMCIA Memory Write Strobe. Active-low. Strobes data to PC-Card during memory write cycles.
16	RDY	I	+Ready/-Busy signal from PC-Card. Allows PC-Card to stall access from the host, in case a previous access's processing is not completed.
17	PCCVCC	O	5V VCC for the PC-Card. Switched by the MPC821ADS, via BCSR1.
18	PCCVPP	O	12V/5V VPP for the PC-Card programming. 12V available only if 12V is applied to P8. Controlled by the MPC821ADS, via BCSR1.
19	PCCA16	O	PCMCIA Address line 16.
20	PCCA15	O	PCMCIA Address line 15.

**Support Information**

**TABLE 5-4. P4 - PCMCIA Connector Interconnect Signals**

Pin No.	Signal Name	Attribute	Description
21	PCCA12	O	PCMCIA Address line 12.
22	PCCA7	O	PCMCIA Address line 7.
23	PCCA6	O	PCMCIA Address line 6.
24	PCCA5	O	PCMCIA Address line 5.
25	PCCA4	O	PCMCIA Address line 4.
26	PCCA3	O	PCMCIA Address line 3.
27	PCCA2	O	PCMCIA Address line 2.
28	PCCA1	O	PCMCIA Address line 1.
29	PCCA0	O	PCMCIA Address line 0.
30	PCCD0	I/O	PCMCIA Data line 0.
31	PCCD1	I/O	PCMCIA Data line 1.
32	PCCD2	I/O	PCMCIA Data line 2.
33	WP	I	Write Protect indication from the PC-Card.
34	GND		Ground
35	GND		Ground
36	CD1~	I	Card Detect 1~. Active-low. Indicates in conjunction with CD2~ that a PC-Card is placed correctly in socket.
37	PCCD11	I/O	PCMCIA Data line 11.
38	PCCD12	I/O	PCMCIA Data line 12.
39	PCCD13	I/O	PCMCIA Data line 13.
40	PCCD14	I/O	PCMCIA Data line 14.
41	PCCD15	I/O	PCMCIA Data line 15.
42	BCE2A~	O	PCMCIA Chip Enable 2. Active-low. Enables ODD numbered address bytes.
43	VS1	I	Voltage Sense 1 from PC-Card. Indicates in conjunction with VS2 the operation voltage for the PC-Card.
44	IORD~	O	I/O Read. Active-low. Drives data bus during I/O-Cards' read cycles.
45	IOWR~	O	I/O Write. Active-low. Strokes data to the PC-Card during I/O-Card write cycles.
46	PCCA17	O	PCMCIA Address line 17.
47	PCCA18	O	PCMCIA Address line 18.
48	PCCA19	O	PCMCIA Address line 19.
49	PCCA20	O	PCMCIA Address line 20.

**Support Information**

**TABLE 5-4. P4 - PCMCIA Connector Interconnect Signals**

Pin No.	Signal Name	Attribute	Description
50	PCCA21	O	PCMCIA Address line 21.
51	PCCVCC	O	5V VCC for the PC-Card. Switched by the MPC821ADS, via BCSR1.
52	PCCVPP	O	12V/5V VPP for the PC-Card programming. 12V available only if 12V is applied to P8. Controlled by the MPC821ADS, via BCSR1.
53	PCCA22	O	PCMCIA Address line 22.
54	PCCA23	O	PCMCIA Address line 23.
55	PCCA24	O	PCMCIA Address line 24.
56	PCCA25	O	PCMCIA Address line 25.
57	VS2	I	Voltage Sense 2 from PC-Card. Indicates in conjunction with VS1 the operation voltage for the PC-Card.
58	RESET	O	Reset signal for PC-Card.
59	WAITA~	I	Cycle Wait from PC-Card. Active-low.
60	INPACK~	I	Input Port Acknowledge. Active-low. Indicates that the Pc-Card can respond to I/O access for a certain address.
61	PCREG~	O	Attribute Memory or I/O Space - Select. Active-low. Used to select either attribute (card-configuration) memory or I/O space.
62	BVD2	I	Battery Voltage Detect 2. Used in conjunction with BVD1 to indicate the condition of the PC-Card's battery.
63	BVD1	I	Battery Voltage Detect 1. Used in conjunction with BVD2 to indicate the condition of the PC-Card's battery.
64	PCCD8	I/O	PCMCIA Data line 8.
65	PCCD9	I/O	PCMCIA Data line 9.
66	PCCD10	I/O	PCMCIA Data line 10.
67	CD2~	I	Card Detect 2~. Active-low. Indicates in conjunction with CD1~ that a PC-Card is placed correctly in socket.
68	GND		Ground.

**5•1•5 P5 - External Debug Port Controller Input Interconnect.**

The debug port connector - P5, is a 10 pin, Male, header connector, signals of which are described in



**Support Information**

TABLE 5-5.

**TABLE 5-5. P5 - Interconnect Signals**

Pin No.	Signal Name	Attribute	Description
1	VFLS0	O	Visible history FLushes Status 0. Indicates in conjunction with VFLS1, the number of instructions flushed from the core's history buffer. Indicates also whether the MPC is in debug mode. If not using the debug port, may be configured for alternate function.
2	SRESET~	I/O	Soft Reset line of the MPC. Active-low, Open-Drain.
3	GND		Ground.
4	DSCK	I/O	Debug Serial Clock. Over the rising edge of which serial date is sampled by the MPC from DSDI signal. Over the falling edge of which DSDI is driven towards the MPC and DSDO is driven by the MPC. Configured on the MPC's JTAG port. When the debug-port controller is on the local MPC or when the ADS is a debug-port controller for a target system - OUTPUT, when the ADI bundle is disconnected from the ADS - INPUT.
5	GND		Ground
6	VFLS1	O	See VFLS0.
7	HRESET~	I/O	Hard Reset line of the MPC. Active-low, Open-Drain
8	DSDI	I/O	Debug Serial Data In of the debug port. Configured on the MPC's JTAG port. When the debug-port controller is on the local MPC or when the ADS is a debug-port controller for a target system - OUTPUT, when the ADI bundle is disconnected from the ADS - INPUT.
9	V3.3	O	3.3V Power indication. This line is merely for indication. No significant power may be drawn from this line.
10	DSDO	I/O	Debug Serial Data Output from the MPC. Configured on the MPC's JTAG port. When the debug-port controller is on the local MPC or when the ADI bundle is disconnected from the ADS - OUTPUT, when the ADS is a debug-port controller for a target system - INPUT.

**5•1•6 P6, P9, P10 & P12 Expansion and Logic Analyzer Connectors.**

Each of these connectors is composed of quad SMD pin-rows. P6 has a 120 pin-count while the rest have 100 pin count. All MPC pins appear in these connectors plus few auxiliary control pins. These connectors are arranged in a quadratic assembly around the MPC to provide short PCB routs. The connectors assembly is shown in FIGURE 5-1 "Expansion Connector Assembly" on page 69. The interconnect signals of the connectors are described in TABLE 5-5. "P5 - Interconnect Signals" on page 67, in TABLE 5-5. "P5 - Interconnect Signals" on page 67, in TABLE 5-8. "P10 - Interconnect Signals" on page 79 and in TABLE 5-9. "P12 - Interconnect Signals" on page 84.

**5•1•6•1 Connecting Application Boards to the Expansion Connectors**

The expansion connectors P6, P9, P10 & P12 are arranged in a way that allows for wire-wrap boards to be connected to it, i.e., connectors' pins are located on a 0.1" snap grid, as shown in FIGURE 5-1. Any board that is to be attached to these connectors, should have a rectangle hole in its center, so that the MPC

### **Support Information**

socket may be accessed. The recommended hole size is shown in FIGURE 5-1 as well.

Connecting an application board to the expansion connectors, requires the following connectors, to match the ADS's connectors:

- 6 units of - Socket-strip, double-row Wire-Wrap, 50 pin (25 X 2 rows), female, straight. E.g.: SSQ12524GD by Samtec.
- 2 units of - Socket-strip, double-row Wire-Wrap, 60 pin (30 X 2 rows), female, straight. E.g.: SSQ13024GD by Samtec.

Using WW connectors even on a printed card, retains logic analyzer connection capability.

ARCHIVED BY FREESCALE SEMICONDUCTOR, INC.

Support Information

FIGURE 5-1 Expansion Connector Assembly

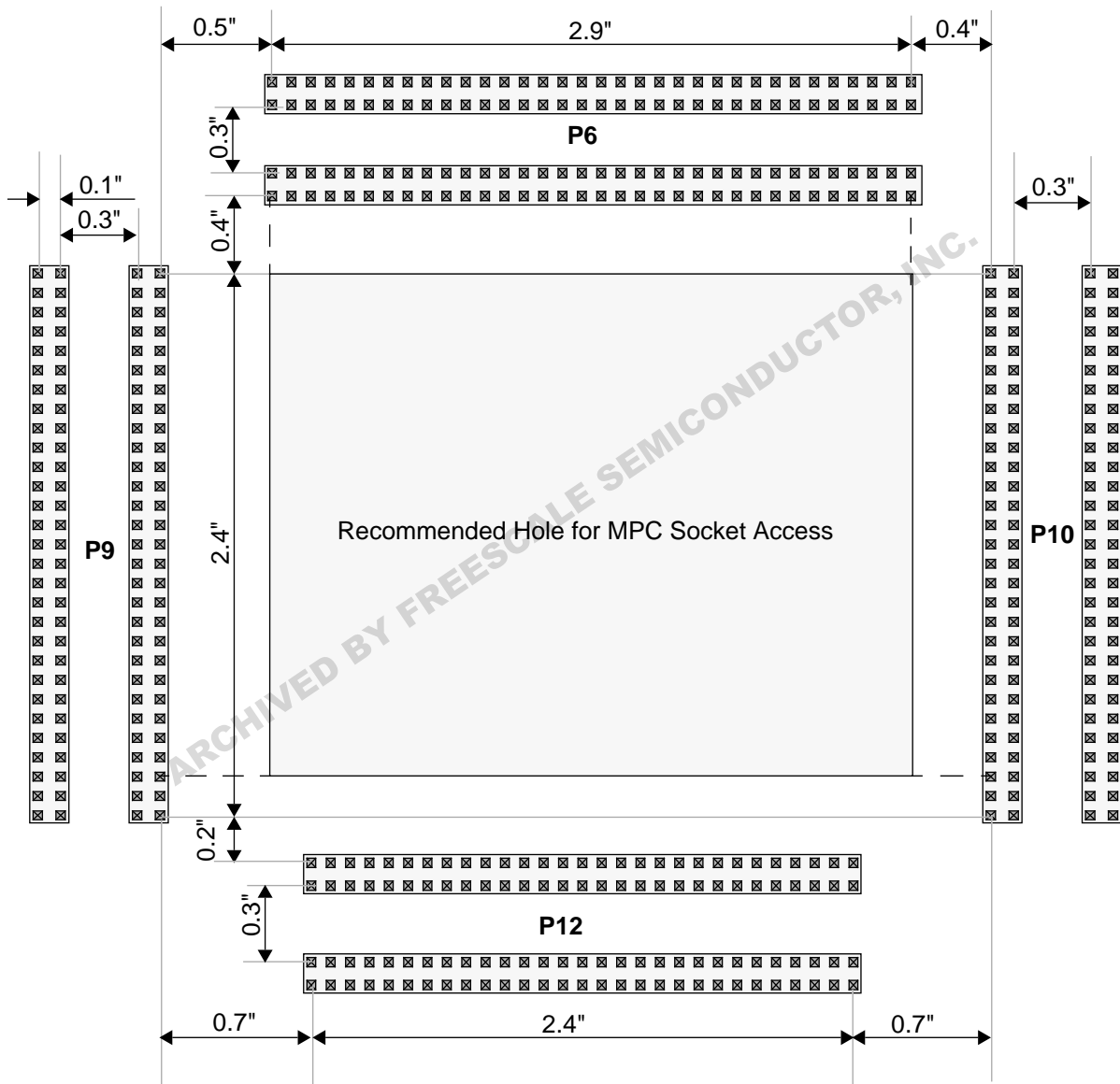

TABLE 5-6. P6 - Interconnect Signals

Pin No.	Signal Name	Attribute	Description
A1	VCC	-	MPC821ADS 5V VCC plane.
A2	VCC	-	
A3	VCC	-	
A4	VCC	-	
A5	TEA~	I/O, L, O.D.	Transfer Error Acknowledge. Pulled-up, not driven on board.
A6	GND	-	MPC821ADS Ground plane.

**Support Information**

**TABLE 5-6. P6 - Interconnect Signals**

Pin No.	Signal Name	Attribute	Description
A7	GPL5B~	O, L	General Purpose Line 5 of UPMB. Not used within the ADS.
A8	GPL4B~	O, L	General Purpose Line 4 of UPMB. Not used within the ADS.
A9	GND	-	.
A10	CE1A~	O, L	PC-Card Enable 1 for PCMCIA slot A. Enables the EVEN address bytes. Used by on-board PCMCIA port. My be used off-board when PCMCIA port in disabled.
A11	CE2A~	O, L	PC-Card Enable 2 for PCMCIA slot A. Enables the ODD address bytes. Used by on-board PCMCIA port. My be used off-board when PCMCIA port in disabled.
A12	GND	-	
A13	GPL2~	O, L	In fact GPL2A~/GPL2B~/CS2DD~. General Purpose Line 2 for UPMA or UPMB. May also be used as Chip-Select 2 Double Drive. Not used within the ADS.
A14	WE1~	O, L	In fact WE1~/BS_B1~/IOWR~. GPCM Write Enable1 or UPMB Byte Select 1 or PCMCIA I/O Write. Used to qualify write cycles to the Flash memory and as I/O Write for the PCMCIA channel.
A15	GND	-	
A16	BS0A~	O, L	Byte Select 0 for UPMA. Used for Dram access.
A17	BS3A~	O, L	Byte Select 3 for UPMA. Used for Dram access.
A18	GND	-	
A19	A21	O, T.S.	MPC's Address line 21.
A20	A7	O, T.S.	MPC's Address line 7.
A21	GND		
A22	A11	O, T.S.	MPC's Address line 11.
A23	A9	O, T.S.	MPC's Address line 9.
A24	GND	-	
A25	A27	O, T.S.	MPC's Address line 27.
A26	A25	O, T.S.	MPC's Address line 25.
A27	GND	-	
A28	A23	O, T.S.	MPC's Address line 23.
A29	A5	O, T.S.	MPC's Address line 5.
A30	GND	-	
B1	VCC	-	MPC821ADS VCC plane.
B2	VCC	-	MPC821ADS VCC plane.
B3	VCC	-	MPC821ADS VCC plane.

**Support Information**

**TABLE 5-6. P6 - Interconnect Signals**

Pin No.	Signal Name	Attribute	Description
B4	DRM_W~	O, L	In fact GPL0A~/GPL0B~. General Purpose Line 0 for UPMA or UPMB. Used as a Write signal for the Dram.
B5	GND	-	.
B6	TA~	I/O, L	Transfer Acknowledge. Not driven by on-board logic.
B7	TS~	O, L, T.S.	MPC Transfer Start. driven only when the MPC is bus master.
B8	GND	-	
B9	BI~	I/O, L, T.S.	Burst Inhibit. Not used on board.
B10	CS5~	O, L	Chip-Select 5. Not used on the ADS.
B11	GND	-	
B12	DRMCS1~	O, L	In fact CS2~ of the MPC. Used for Dram bank 1 selection.
B13	GPL3~	O, L	In fact GPL3A~/GPL3B~/CS3DD~. General Purpose Line 3 for UPMA or UPMB. May also be used as Chip-Select 3 Double Drive. Not used within the ADS.
B14	GND	-	
B15	WE0~	O, L	In fact WE0~/BS_B0~/ IORD~. GPCM Write Enable 0 or UPMB Byte Select 0 or PCMCIA I/O Read. Used to qualify write cycles to the Flash memory and as I/O Read for the PCMCIA channel.
B16	EDOOE~	O, L	In fact OE~/GPL1A~/GPL1B~. GPCM Output Enable or UPMA General Purpose Line 1 or UPMB General Purpose Line 1. Used as an Output Enable for EDO Drams, controlled by UPMA.
B17	GND	-	
B18	REG_A~	O, T.S.	In fact TSIZ0/REG~. Transfer Size 0 or PCMCIA slot A REG~. Used with the PCMCIA port as Attribute memory select or I/O space select.
B19	A30	O, T.S.	MPC's Address line 30.
B20	GND	-	
B21	A6	O, T.S.	MPC's Address line 6.
B22	A12	O, T.S.	MPC's Address line 12.
B23	GND	-	
B24	A16	O, T.S.	MPC's Address line 16.
B25	A29	O, T.S.	MPC's Address line 29.
B26	GND	-	
B27	N.C.	-	Not Connected
B28	A3	O, T.S.	MPC's Address line 3.

**Support Information**

**TABLE 5-6. P6 - Interconnect Signals**

Pin No.	Signal Name	Attribute	Description
B29	GND	-	
B30	A0	O, T.S.	MPC's Address line 0.
C1	VCC	-	MPC821ADS VCC plane.
C2	VCC	-	MPC821ADS VCC plane.
C3	VCC	-	MPC821ADS VCC plane.
C4	VCC	-	MPC821ADS VCC plane.
C5	BURST~	O, T.S.	Burst Transaction Indicator.
C6	GPL4A~	I/O, L	UPWAITA~/GPL4A~. UPMA Wait signal or UPMA General Purpose Line 4. Not used on ADS.
C7	GND	-	
C8	BCSRCS~	O, L	In fact Chip-Select 1. Used as a Chip-Select for the BCSR, controlled by the GPCM. May be used off-board when BCSR is disabled.
C9	GPL5A~	O, L	UMPA General Purpose Line 5. Not used on the ADS.
C10	GND	-	
C11	CS6~	O, L	in fact CS6~/CE1_B~. Chip-Select 6 or PCMCIA slot B CE1~. Not used on the ADS.
C12	DRMCS2~	O, L	In fact CS3~. Selects the upper bank (if exists) of the Dram. May be used off-board if either exist: (a) the on-board Dram SIMM is a single-bank SIMM or (b) the Dram is disabled from local memory map via BCSR1.
C13	GND	-	
C14	WE2~	O, L	In fact WE2~/BS2_B~/PCOE~. Used as Write Enable 2 for the Flash memory and as a PCMCIA Output Enable.
C15	BS2A~	O, L	Byte Select 2 for UPMA. Used for Dram access.
C16	GND	-	
C17	BS1A~	O, L	Byte Select 1 for UPMA. Used for Dram access.
C18	TSIZ1	O, T.S.	Transfer Size 1. Used in conjunction with TSIZ0 to indicate the number of bytes remaining in an operand transfer. Not used on the ADS.
C19	GND	-	
C20	A14	O, T.S.	MPC's Address line 14.
C21	A13	O, T.S.	MPC's Address line 13.
C22	GND	-	
C23	A10	O, T.S.	MPC's Address line 10.
C24	A17	O, T.S.	MPC's Address line 17.

**Support Information**

**TABLE 5-6. P6 - Interconnect Signals**

Pin No.	Signal Name	Attribute	Description
C25	GND	-	
C26	A26	O, T.S.	MPC's Address line 26.
C27	A24	O, T.S.	MPC's Address line 24.
C28	GND	-	
C29	A2	O, T.S.	MPC's Address line 2.
C30	A1	O, T.S.	MPC's Address line 1.
D1	VCC	-	MPC821ADS VCC plane.
D2	VCC	-	MPC821ADS VCC plane.
D3	VCC	-	MPC821ADS VCC plane.
D4	BB~	I/O, L	Bus Busy. Pulled-up. Not used on the ADS.
D5	BR~	I/O, L	Bus Request. Pulled Up. Not used on the ADS.
D6	GND	-	
D7	BG~	I/O, L	Bus Grant. Pulled Up. Not used on the ADS.
D8	R_W~	O, T.S.	Read/Write~. Used to change data buffers' direction.
D9	GND	-	
D10	CS7~	O, L	CS7~/CE2_B~. Chip-Select 6 or PCMCIA slot B CE2~. Not used on the ADS.
D11	F_CS~	O, L	In fact CS0~. Used as a main chip-select for the Flash memory, from which the individual banks' chip-selects are derived. May be used off-board when the Flash is disabled via BCSR1.
D12	GND	-	
D13	CS4~	O, L	Chip-select 4. Not used on the ADS.
D14	WE3~		WE3~/BS3_B~/PCWE~. GPCM Write Enable 3 or UPMB Byte Select 3 or PCMCIA Write Enable signal. Used as WE3~ for the Flash memory or as WE
D15	GND	-	
D16	SPARE1	-	MPC spare pin 1.
D17	A31	O, T.S.	MPC's Address line 31.
D18	GND	-	
D19	A20	O, T.S.	MPC's Address line 20.
D20	A15	O, T.S.	MPC's Address line 15.
D21	GND	-	
D22	A19	O, T.S.	MPC's Address line 19.
D23	A18	O, T.S.	MPC's Address line 18.

**Support Information**

**TABLE 5-6. P6 - Interconnect Signals**

Pin No.	Signal Name	Attribute	Description
D24	GND	-	.
D25	A8	O, T.S.	MPC's Address line 8.
D26	A28	O, T.S.	MPC's Address line 28.
D27	GND	-	
D28	A22	O, T.S.	MPC's Address line 22.
D29	A4	O, T.S.	MPC's Address line 4.
D30	GND	-	

**TABLE 5-7. P9 - Interconnect Signals**

Pin No.	Signal Name	Attribute	Description
A1	GND	-	
A2	AT2	I/O	IP_B2/IOIS16~/AT2. PCMCIA slot B Input Port 2 or PCMCIA 16 bit I/O capability indication or Address Type 2. Configured on the ADS as AT2. May be configured to alternate function.
A3	VF2	I/O	IP_B3/IWP2/VF2. PCMCIA slot B Input Port 3 or Instruction Watch-Point 2 or Visible Instruction Queue Flushes Status 2. Configured on the ADS as VF2. May be configured to alternate function.
A4	GND	-	
A5	AT3	I/O	IP_B7/PTR/AT3. PCMCIA slot B Input Port 7 or Program Trace (instruction fetch indication or Address Type 3. Configured on the ads as AT3. May be configured to alternate function.
A6	SPKROUT	I/O	KR~/IRQ4~/SPKROUT. Kill Reservation input or Interrupt Request 4 input or PCMCIA Speaker Output. Configured on the ADS as SPKROUT. May be configured to alternate function.
A7	GND	-	
A8	POE_A~	O, L	In fact OP1 of the PCMCIA I/F. Enables address buffers towards the PC-Card.
A9	BADDR29	-	Burst Address Line 29. Dedicated for external master support. Used to generate Burst address during external master burst cycles.
A10	GND	-	
A11	KAPWR	-	Keep Alive Power rail.
A12	WAIT_B~	I, L	This signal is PCMCIA slot B wait signal. Pulled-up. Not used otherwise.
A13	GND	-	



**Support Information**

**TABLE 5-7. P9 - Interconnect Signals**

Pin No.	Signal Name	Attribute	Description
A14	GND	-	
A15	GND	-	
A16	GND	-	
A17	BWP	I, H	Buffered PCMCIA slot A Write Protect. In fact IP_A2/IOIS16A~. Used as PC-card write protect indication or as 16 bit I/O capability indication for PCMCIA slot A. When the PCMCIA port is disabled via BCSR1, this line may be used off-board.
A18	BRDY	I, H	Buffered PCMCIA slot A Ready signal. In fact IP_A7. Used as PCMCIA port A Card Ready indication. When the PCMCIA port is disabled via BCSR1, this line may be used off-board.
A19	GND	-	
A20	N.C.	-	Not Connected
A21	V3.3	-	3.3V Power Rail.
A22	V3.3	-	
A23	V3.3	-	
A24	V3.3	-	
A25	V3.3	-	
B1	GND	-	
B2	GND	-	
B3	GND	-	
B4	IRQ3~	I, L	CR~/IRQ3~. Cancel Reservation input or Interrupt Request line 3. Pulled-up but otherwise unused on the ADS.
B5	IRQ2~	I/O, L	RSV~/IRQ2~. Reservation output or Interrupt Request line 2 input. Pulled-up but otherwise unused on the ADS.
B6	GND	-	
B7	VF1	I/O	IP_B5/LWP1/VF1. Input Port B 5 or Load/Store Watchpoint 1 output or Visible Instruction Queue Flushes Status 1. Configured on the ADS as VF1. May be used for alternate function.
B8	AT0	I	IP_B6/DSDI/AT0. Input Port B 6 or Debug Serial Data Input or Address Type 0. Configured on the as AT0. May be used for alternate function.
B9	GND	-	
B10	MODCK1	I/O	OP2/MODCK1/STS~. PCMCIA Output Port 2 or Mode Clock 1 input or Special Transfer Start output. Used at Power-On reset as MODCK1 and configured afterwards as a STS~. May be used with alternate function.

**Support Information**

**TABLE 5-7. P9 - Interconnect Signals**

Pin No.	Signal Name	Attribute	Description
B11	N.C.	-	Not Connected
B12	GND	-	
B13	GND	-	
B14	CLK4IN	I	External Clock Input. Driven by on-board 4MHz clock generator.
B15	GND	-	
B16	HRESET~	I/O, L, O.D.	MPC Hard Reset. Driven by on-board logic and may be driven by off-board logic with Open-Drain gate only.
B17	RSTCNF~	I, L	Hard Reset Configuration Input. Driven during Hard Reset to sample Hard Reset configuration from the data bus.
B18	GND	-	
B19	BCD1~	I, L	Buffered PCMCIA slot A Card Detect 1. In fact IP_A4. Input Port 4 of PCMCIA slot A. Used as Card Detect indication in conjunction with BCD2~. When the PCMCIA port is disabled via BCSR, may be used off-board.
B20	BCD2~	I, L	Buffered PCMCIA slot A Card Detect 2 In fact IP_A3. Input Port 4 of PCMCIA slot A. Used as Card Detect indication in conjunction with BCD1~. When the PCMCIA port is disabled via BCSR, may be used off-board.
B21	GND	-	
B22	DP1	I/O	DP1/IRQ4~. Data Parity line1 or Interrupt Request 4. Generates and receives parity data for D(8:15) bits. May not be configured as IRQ4~.
B23	N.C.	-	Not Connected
B24	N.C.	-	Not Connected
B25	N.C.	-	Not Connected
C1	GND	-	
C2	SYSCLK	O	System Clock. In fact the CLKOUT of the MPC. Should be used carefully off-board, otherwise might disrupt proper operation of the ADS.
C3	GND	-	
C4	GND	-	
C5	IRQ6~	I/O	FRZ/IRQ6~. Freeze (debug-mode) indication or Interrupt Request 6~. Configured on the ADS as IRQ6~. Not by ADS logic, may be configured to alternate function if IRQ6~ is not required.

**Support Information**

**TABLE 5-7. P9 - Interconnect Signals**

Pin No.	Signal Name	Attribute	Description
C6	VFLS0		IP_B0/IWP0/VFLS0. PCMCIA slot B Input Port 0 or Instruction Watchpoint 0 or Visible history FLushes Status 0. Configured on the ADS as VFLS0. Indicates in conjunction with VFLS1, the number of instructions flushed from the core's history buffer. Indicates also whether the MPC is in debug mode. If not using the debug port, may be configured for alternate function.
C7	GND	-	
C8	AT1	I/O	ALE_B/DSCK/AT1. Address Latch Enable for PCMCIA slot B or Debug Serial Clock or Address Type 1. Configured on the ADS as AT1. Not used on the ADS. May be configured to alternate function.
C9	ALE_A	O, H	Address Latch Enable for PCMCIA slot A. Latches address in external latches at the beginning of access to a PC-Card.
C10	GND	-	
C11	RESETA	O, H	In fact OP0. Serves as PC-Card reset signal.
C12	TEXP	O, H	Timer Expired. Not used on the ADS.
C13	GND	-	
C14	GND	-	
C15	GND	-	
C16	GND	-	
C17	BWAITA~		Buffered PCMCIA slot A WAIT signal. Used to prolong cycles to slow PC-Cards. When the PCMCIA port is disabled via BCSR1, may be used off-board.
C18	BVS1	I	Buffered PCMCIA slot A Voltage Sense 1. In fact IP_A0. Used in conjunction with BVS2 to determine the operation voltage of a PCMCIA card. When the PCMCIA port is disabled via BCSR1, may be used off-board.
C19	GND	-	
C20	BBVD1	I	Buffered PCMCIA slot A Battery Voltage Detect 1. In fact IP_A6. Used in conjunction with BBVD2 to determine the battery status of a PC-Card. When the PCMCIA port is disabled via BCSR1, may be used off-board.
C21	DP0	I/O	DP0/IRQ3~. Data Parity line 0 or Interrupt Request 3. Generates and receives parity data for D(0:7) bits. May not be configured as IRQ3~.
C22	GND	-	
C23	N.C.	-	Not Connected.
C24	N.C.	-	Not Connected.
C25	N.C.	-	Not Connected.

**Support Information**

**TABLE 5-7. P9 - Interconnect Signals**

Pin No.	Signal Name	Attribute	Description
D1	GND	-	
D2	GND	-	
D3	GND	-	
D4	VF1	I/O	IP_B5/LWP1/VF1. PCMCIA slot B Input Port 5 or Load/Store Watch-Point 1 or Visible Instruction Queue Flushes Status 1. Configured on the ADS as VF1. May be configured to alternate function.
D5	GND	-	
D6	SPARE4	-	MPC spare pin 4.
D7	VFLS1	I/O	IP_B1/IWP1/VFLS1. PCMCIA slot B Input Port 1 or Instruction Watchpoint 1 or Visible history FLushes Status 1. Configured on the ADS as VFLS1. Indicates in conjunction with VFLS0, the number of instructions flushed from the core's history buffer. Indicates also whether the MPC is in debug mode. If not using the debug port, may be configured for alternate function.
D8	GND	-	
D9	BADDR30	O	Burst Address Line 30. Dedicated for external master support. Used to generate Burst address during external master burst cycles. Valid only when 16 bit memory is being accessed by the external master.
D10	AS~	I, L	Asynchronous external master Address Strobe signal. When asserted (L) by the external master, the MPC recognizes an asynchronous cycle in progress.
D11	GND	-	
D12	BADDR28	-	Burst Address Line 28. Dedicated for external master support. Used to generate Burst address during external master burst cycles.
D13	MODCK2	I/O	OP3/MODCK2/DSDO. PCMCIA Output Port 3 or Mode Clock 2 input or Special Transfer Start output. Used at Power-On reset as MODCK2 and configured afterwards as a OP3. May be used with alternate function.
D14	GND	-	
D15	SRESET~	I/O, L, O.D.	MPC Soft Reset. Driven by on-board logic and may be driven by off-board logic with Open-Drain gate only.
D16	KAPORO~	I, L	Keep Alive Power On Reset Output. In fact Power On Reset Input of the MPC. Driven by the on-board reset logic.
D17	GND	-	
D18	DP3		DP3/IRQ6~. Data Parity line 3 or Interrupt Request 6. Generates and receives parity data for D(24:31) bits. May not be configured as IRQ6~. (IRQ6~ is already configured on the FRZ pin).

**Support Information**

**TABLE 5-7. P9 - Interconnect Signals**

Pin No.	Signal Name	Attribute	Description
D19	BVS2	I	Buffered PCMCIA slot A Voltage Sense 2. In fact IP_A1. Used in conjunction with BVS1 to determine the operation voltage of a PCMCIA card. When the PCMCIA port is disabled via BCSR1, may be used off-board.
D20	GND	-	
D21	BBVD2	I	Buffered PCMCIA slot A Battery Voltage Detect 2. In act IP_A5. Used in conjunction with BBVD1 to determine the battery status of a PC-Card. When the PCMCIA port is disabled via BCSR1, may be used off-board.
D22	DP2	I/O	DP2/IRQ5~. Data Parity line 2 or Interrupt Request 5. Generates and receives parity data for D(16:23) bits. May not be configured as IRQ5~.
D23	V2	-	2V Power Rail. Optional for driving MPC VDDL.
D24	V2	-	
D25	V2	-	

**TABLE 5-8. P10 - Interconnect Signals**

Pin No.	Signal Name	Attribute	Description
A1	GND	-	
A2	PA11	I/O	PA11/L1TXDB. Not used on the ADS. Appears also at P13.
A3	PA10	I/O	PA10/L1RXDB. Not used on the ADS. Appears also at P13.
A4	GND	-	
A5	PA9	I/O	PA9/L1TXDA. Not used on the ADS. Appears also at P13.
A6	PA8	I/O	PA8/L1RXDA. Not used on the ADS. Appears also at P13.
A7	GND	-	
A8	ETHTCK	I/O	Ethernet Port Transmit Clock. In fact PA7/CLK1/TIN1/L1RCLKA/BRGO1. When the Ethernet port is disabled via BCSR1, may be used off-board for any alternate function. Appears also at P13.
A9	ETHRCK	I/O	Ethernet Port Receive Clock. In fact PA7/CLK2/TOUT1~/BRGCLK1. When the Ethernet port is disabled via BCSR1, may be used off-board for any alternate function. Appears also at P13.
A10	GND	-	
A11	PA5	I/O	PA5/CLK3/TIN2/L1TCLKA/BRGOUT2. Not used on the ADS. Appears also at P13.
A12	PA4	I/O	PA4/CLK4/TOUT2~. Not used on the ADS. Appears also at P13.

**Support Information**

**TABLE 5-8. P10 - Interconnect Signals**

Pin No.	Signal Name	Attribute	Description
A13	GND	-	
A14	PA3	I/O	PA3/CLK5/TIN3/BRGOUT3. Not used on the ADS.
A15	PA2	I/O	PA2/CLK6/TOUT3/L1RCLKB/BRGCLK2. Not used on the ADS.
A16	GND	-	
A17	PA1	I/O	PA1/CLK7/TIN4/BRGO4. Not used on the ADS.
A18	PA0	I/O	PA0/CLK8/TOUT4/L1TCLKB. Not used on the ADS.
A19	GND	-	
A20	SHIFT_C	I/O	MPC821's PD3/SHIFT/CLK. Not used on the ADS. Appears also at P11 for convenient LCD connection.
A21	LD0	I/O	MPC821's PD7/LD0. Not used on the ADS. Appears also at P11 for convenient LCD connection.
A22	LD8	I/O	MPC821's PD15/LD8. Not used on the ADS. Appears also at P11 for convenient LCD connection.
A23	LD6	I/O	MPC821's PD13/LD6. Not used on the ADS. Appears also at P11 for convenient LCD connection.
A24	GND	-	
A25	NMI~	I/O, L	Non-Makable Interrupt. In fact IRQ0~ of the MPC. Driven by on-board logic by O.D. gate. May be driven off-board by O.D. gate only.
B1	GND	-	
B2	ETHRX	I/O	Ethernet port Receive Data. In fact PA15/RXD1. When the Ethernet port is disabled via BCSR1, may be used off-board.
B3	GND	-	
B4	ETHTX	I/O	Ethernet port Transmit Data. In fact PA14/TXD1. When the Ethernet port is disabled via BCSR1, may be used off-board for any alternate function.
B5	GND	-	
B6	RSTXD	I/O	RS232 port Transmit Data. In fact PB25/SMTXD1. When the RS232 port is disabled via BCSR1, may be used off-board for any alternate function.
B7	RSRXD	I/O	RS232 port Receive Data. In fact PB24/SMRXD1. When the RS232 port is disabled via BCSR1, may be used off-board for any alternate function.
B8	RSDTR~	I/O	RS232 port DTR~ signal. In fact PB23/SMSYN1~/SDACK1~. When the RS232 port is disabled via BCSR1, may be used off-board for any alternate function.
B9	GND	-	
B10	PB20	I/O	PB20/SMRXD2/L1CLKOA. Not used on the ADS.

**Support Information**

**TABLE 5-8. P10 - Interconnect Signals**

Pin No.	Signal Name	Attribute	Description
B11	PB21	I/O	PB21/SMTXD2/L1CLKOB. Not used on the ADS.
B12	PB22	I/O	PB22/SMSYN2~/SDACK2~. Not used on the ADS.
B13	GND	-	
B14	PB17	I/O	PB17/L1RQB/L1ST3. Not used on the ADS.
B15	PB18	I/O	PB18/RTS2~/L1ST2. Not used on the ADS.
B16	E_TENA	I/O, H	Ethernet port Transmit Enable. In fact PB19/RTS1~/L1ST1. When active, transmit is enabled via the MC68160 EEST. When the ethernet port is disabled via BCSR1, may be used off-board for any alternate function.
B17	GND	-	
B18	PB16	I/O	PB16/L1RQA/L1ST4. Not used on the ADS.
B19	PB15	I/O	PB15/BRGO3. Not used on the ADS.
B20	PB14	I/O	PB14/RSTR1~. Not used on the ADS.
B21	GND	-	
B22	LOE		MPC821's PD6/LCD_AC/LOE. Not used on the ADS. Appears also at P11 for convenient LCD connection.
B23	LD2		MPC821's PD9/LD2. Not used on the ADS. Appears also at P11 for convenient LCD connection.
B24	LD1		MPC821's PD8/LD1. Not used on the ADS. Appears also at P11 for convenient LCD connection.
B25	SPARE3	-	MPC spare pin 3.
C1	VCC	-	MPC821ADS VCC plane.
C2	VCC	-	MPC821ADS VCC plane.
C3	IRDRXD	I/O	InfraRed Port Receive Data. In fact PA13/RXD2. When the Infra-Red port is disabled, may be used off-board for any alternate function.
C4	IRDTXD	I/O	InfraRed Port Transmit Data. In fact PA12/TXD2. When the Infra-Red port is disabled via BCSR1, may be used off-board for any alternate function.
C5	GND	-	
C6	BINPAK~	I/O	PCMCIA port Input Port Acknowledge. In fact PC15/DREQ1~/RTS1~/L1ST1. When the PCMCIA port is disabled via BCSR1, may be used off-board for any alternate function.
C7	PC14	I/O	PC14/DREQ2~/RTS2~/L1ST2. Not used on the ADS.
C8	PC13	I/O	PC13/L1RQB/L1ST3. Not used on the ADS.
C9	GND	-	

**Support Information**

**TABLE 5-8. P10 - Interconnect Signals**

Pin No.	Signal Name	Attribute	Description
C10	PC12	I/O	PC12/L1RQA/L1ST4. Not used on the ADS.
C11	E_CLSN	I/O, H	Ethernet Port Collision indication signal <sup>3</sup> . In fact PC11/CTS1~. When the ethernet port is disabled via BCSR1, may be used off-board for any alternate function.
C12	E_RENA	I/O, H	Ethernet Receive Enable. In fact PC10/CD1~/TGATE1~. Active when there is network activity. When the ethernet port is disabled via BCSR1, may be used off-board for any alternate function.
C13	GND	-	.
C14	PC9	I/O	PC9/CTS2~. Not used on the ADS.
C15	PC8	I/O	PC8/CD2~/TGATE2~. Not used on the ADS.
C16	PC7	I/O	PC7/L1TSYNCB/SDACK2~. Not used on the ADS.
C17	GND	-	.
C18	ETHLOOP	I/O, H	Ethernet port Diagnostic Loop-Back. In fact PC4/L1RSYNCA. When active, the MC68160 EEST is configured into diagnostic Loop-Back mode, where the transmit output is internally fed back into the receive section. Since after hard reset, this line wakes-up tri-stated, it should be initialized as output and given the desired value. When the ethernet port is disabled via BCSR1, may be used off-board for any alternate function.
C19	TPFLDL~	I/O, L	Twisted Pair Full-Duplex. In fact PC5/L1TSYNCA/SDACK1~. When active, the MC68160 EEST is put into full-duplex mode, where, simultaneous receive and transmit are enabled. Since after hard reset, this line wakes-up tri-stated, it should be initialized as output and given the desired value. When the ethernet port is disabled via BCSR1, may be used off-board for any alternate function.
C20	TPSQEL~	I/O, L	Twisted Pair Signal Quality Error Test Enable. In-fact PC6/L1RSYNCB. When active, a simulated collision state is generated within the EEST, so the collision detection circuitry within the EEST may be tested. Since after hard reset, this line wakes-up tri-stated, it should be initialized as output and given the desired value. When the ethernet port is disabled via BCSR1, may be used off-board for any alternate function.
C21	GND	-	.
C22	VSYNC	I/O	MPC821's PD5/FRAME/VSYNC. Not used on the ADS. Appears also at P11 for convenient LCD connection.
C23	LD7	I/O	MPC821's PD14/LD7. Not used on the ADS. Appears also at P11 for convenient LCD connection.
C24	LD3	I/O	MPC821's PD10/LD3. Not used on the ADS. Appears also at P11 for convenient LCD connection.



**Support Information**

**TABLE 5-8. P10 - Interconnect Signals**

Pin No.	Signal Name	Attribute	Description
C25	IRQ7~	I, L	Interrupt Request 7. The lowest priority interrupt request line. Not used on the ADS.
D1	VCC	-	MPC821ADS VCC plane.
D2	VCC	-	MPC821ADS VCC plane.
D3	VCC	-	MPC821ADS VCC plane.
D4	PB31	I/O	PB31/SPISEL~/RRJECT1~. Not used on the ADS.
D5	PB30	I/O	PB30/SPICLK. Not used on the ADS.
D6	PB29	I/O	PB29/SPI MOSI. Not used on the ADS.
D7	GND	-	
D8	PB28	I/O	PB28/SPI MISO/BRGO4. Not used on the ADS.
D9	PB27	I/O	PB27/I2CSDA/BRGO1. Not used on the ADS.
D10	PB26	I/O	PB26/I2CSCL/BRGO2. Not used on the ADS.
D11	GND	-	
D12	SPARE2	-	MPC spare pin 2.
D13	DSDO	O	DSDO/TDO. Debug Port Serial Data Output or JTAG port Data Output. Used on the ADS as debug port serial data. If the ADI bundle is not connected to the ADS, may be used by an external debug / JTAG <sup>b</sup> port controllers.
D14	GND	-	
D15	DSCK	I/O	DSCK/TCK. Debug Port Serial Clock input or JTAG port serial clock input. Used on the ADS as debug port serial clock, driven by the debug-port controller. If the ADI bundle is not connected to the ADS, may be driven by an external debug / JTAG <sup>b</sup> port controller.
D16	GND	-	
D17	DSDI	I/O	DSDI/TDI. Debug Port Serial Data Input or JTAG port serial Data Input. Used on the ADS as debug port serial data, driven by the debug-port controller. If the ADI bundle is not connected to the ADS, may be driven by external debug / JTAG <sup>b</sup> port controller.
D18	TMS	I	JTAG port Test Mode Select input. Used to select test through the JTAG port. Pulled-up but otherwise not used on the ADS.
D19	TRST~	I, L	JTAG port Reset. Pulled down with a zero ohm resistor, so that the JTAG logic is constantly reset.
D20	GND	-	
D21	HSYNC	I/O	MPC821's PD4/LOAD/HSYNC. Not used on the ADS. Appears also at P11 for convenient LCD connection.
D22	LD5	I/O	MPC821's PD12/LD5. Not used on the ADS. Appears also at P11 for convenient LCD connection.

**Support Information**

**TABLE 5-8. P10 - Interconnect Signals**

Pin No.	Signal Name	Attribute	Description
D23	LD4	I/O	MPC821's PD11/LD4 . Not used on the ADS. Appears also at P11 for convenient LCD connection.
D24	GND	-	
D25	IRQ1~	I, L	Interrupt Request 1.Pulled-up but otherwise not used on the ADS.

- a. There is also a visible collision indication.
- b. Be aware that TRST~ is connected to GND with a zero ohm resistor.

**TABLE 5-9. P12 - Interconnect Signals**

Pin No.	Signal Name	Attribute	Description
A1	GND	-	
A2	GND	-	
A3	GND	-	
A4	GND	-	
A5	GND	-	
A6	GND	-	
A7	GND	-	
A8	D3	I/O	MPC's data line 3.
A9	D0	I/O	MPC's data line 0.
A10	GND	-	
A11	D19	I/O	MPC's data line 19.
A12	D16	I/O	MPC's data line 16.
A13	GND	-	
A14	D11	I/O	MPC's data line 11.
A15	D8	I/O	MPC's data line 8.
A16	GND	-	
A17	D27	I/O	MPC's data line 27.
A18	D25	I/O	MPC's data line 25.
A19	GND	-	
A20	EXTOLI1	I	External Tool Identification 1. Connected to BCSR2. See 4•14•4 "BCSR2 - Board Status Register - 1" on page 51.
A21	EXTOLI0	I	External Tool Identification 0. Connected to BCSR2. See 4•14•4 "BCSR2 - Board Status Register - 1" on page 51.

**Support Information**

**TABLE 5-9. P12 - Interconnect Signals**

Pin No.	Signal Name	Attribute	Description
A22	EXTOLI3	I	External Tool Identification 3. Connected to BCSR2. See 4•14•4 "BCSR2 - Board Status Register - 1" on page 51.
A23	GND	-	
A24	GND	-	
A25	GND	-	
B1	GND	-	
B2	GND	-	
B3	GND	-	
B4	GND	-	
B5	GND	-	
B6	GND	-	
B7	D6	I/O	MPC's data line 6.
B8	D4	I/O	MPC's data line 4.
B9	GND	-	
B10	D22	I/O	MPC's data line 22.
B11	D20	I/O	MPC's data line 20.
B12	GND	-	
B13	D14	I/O	MPC's data line 14.
B14	D12	I/O	MPC's data line 12.
B15	GND	-	
B16	D30	I/O	MPC's data line 30.
B17	D28	I/O	MPC's data line 28.
B18	GND	-	
B19	EXTOLI2	I	External Tool Identification 2. Connected to BCSR2. See 4•14•4 "BCSR2 - Board Status Register - 1" on page 51.
B20	FCFGEN~	O, L	Flash Configuration Enable. Connected to BCSR1. See 4•14•3 "BCSR1 - Board Control Register" on page 49.
B21	PCVCCON~	O, L	PCMCIA Card VCC ON. Connected to BCSR1. See 4•14•3 "BCSR1 - Board Control Register" on page 49.
B22	GND	-	
B23	IRD_EN~	O, L	Infra-Red Enable. Connected to BCSR1. See 4•14•3 "BCSR1 - Board Control Register" on page 49.
B24	PCCVPP1	O	PCMCIA Card VPP control 1. Connected to BCSR1. See 4•14•3 "BCSR1 - Board Control Register" on page 49.

**Support Information**

**TABLE 5-9. P12 - Interconnect Signals**

Pin No.	Signal Name	Attribute	Description
B25	PCCVPP0	O	PCMCIA Card VPP control 0. Connected to BCSR1. See 4•14•3 "BCSR1 - Board Control Register" on page 49.
C1	GND	-	
C2	GND	-	
C3	GND	-	
C4	GND	-	
C5	GND	-	
C6	GND	-	
C7	D7	I/O	MPC's data line 7.
C8	GND	-	
C9	D1	I/O	MPC's data line 1.
C10	D23	I/O	MPC's data line 23.
C11	GND	-	
C12	D17	I/O	MPC's data line 17.
C13	D15	I/O	MPC's data line 15.
C14	GND	-	
C15	D9	I/O	MPC's data line 9.
C16	D31	I/O	MPC's data line 31.
C17	GND	-	
C18	D26	I/O	MPC's data line 26.
C19	ETHEN~	O, L	Ethernet Port Enable. Connected to BCSR1. See 4•14•3 "BCSR1 - Board Control Register" on page 49.
C20	DRAMEN~	O, H	DRAM Enable. Connected to BCSR1. See 4•14•3 "BCSR1 - Board Control Register" on page 49.
C21	PCCEN~	O, L	PCMCIA port Enable. Connected to BCSR1. See 4•14•3 "BCSR1 - Board Control Register" on page 49.
C22	GND	-	
C23	DRMPD5	O	Dram Presence Detect line 5. Connected to BCSR2. See 4•14•4 "BCSR2 - Board Status Register - 1" on page 51.
C24	DRMPD4	O	Dram Presence Detect line 4. Connected to BCSR2. See 4•14•4 "BCSR2 - Board Status Register - 1" on page 51.
C25	DRMPD3	O	Dram Presence Detect line 3. Connected to BCSR2. See 4•14•4 "BCSR2 - Board Status Register - 1" on page 51.
D1	GND	-	

**Support Information**

**TABLE 5-9. P12 - Interconnect Signals**

Pin No.	Signal Name	Attribute	Description
D2	GND	-	
D3	GND	-	
D4	GND	-	
D5	GND	-	
D6	GND	-	
D7	GND	-	
D8	D5	I/O	MPC's data line 5.
D9	D2	I/O	MPC's data line 2.
D10	GND	-	
D11	D21	I/O	MPC's data line 21.
D12	D18	I/O	MPC's data line 18.
D13	GND	-	
D14	D13	I/O	MPC's data line 13.
D15	D10	I/O	MPC's data line 10.
D16	GND	-	
D17	D29	I/O	MPC's data line 29.
D18	GND	-	
D19	D24	I/O	MPC's data line 24.
D20	RS_EN~	O, L	RS232 port Enable. Connected to BCSR1. See 4•14•3 "BCSR1 - Board Control Register" on page 49.
D21	DRMH_W~	O, L	Dram Half Word. Connected to BCSR1. See 4•14•3 "BCSR1 - Board Control Register" on page 49.
D22	DRMPD1	O	Dram Presence Detect line 1. Connected to BCSR2. See 4•14•4 "BCSR2 - Board Status Register - 1" on page 51.
D23	F_EN~	O, L	Flash Enable. Connected to BCSR1. See 4•14•3 "BCSR1 - Board Control Register" on page 49.
D24	BCSREN~	O, L	Board Control Status Register Enable. Connected to BCSR1. See 4•14•3 "BCSR1 - Board Control Register" on page 49.
D25	DRMPD2	O	Dram Presence Detect line 2. Connected to BCSR2. See 4•14•4 "BCSR2 - Board Status Register - 1" on page 51.

**5•1•7 P7 - 5V Power Connector**

The 5V power connector - P7, is a 3-lead, two-part terminal block. The male part is soldered to the pcb,

**Support Information**

while the receptacle is connected to the power supply. That way fast connection / disconnection of power is facilitated and physical efforts are avoided on the solders, which therefore maintain solid connection over time.

**TABLE 5-10. P7 - Interconnect Signals**

Pin Number	Signal Name	Description
1	5V	5V input from external power supply.
2	GND	GND line from external power supply.
3	GND	GND line from external power supply.

**5•1•8 P8 - 12V Power Connector**

The 12V power connector - P8, is a two-lead, 2 part, terminal block connector, identical in type to the 5V connector. P8 supplies, when necessary, programming voltage to the PCMCIA slot.

**TABLE 5-11. P8 - Interconnect Signals**

Pin Number	Signal Name	Description
1	12V	12V input from external power supply.
2	GND	GND line from external power supply.

**5•1•9 P11 - LCD Connector**

The LCD connector - P11, is a 30 pin, Male, Header SMD connector, meant to ease connection to LCD's

**Support Information**

to their various types. All P11 signals exist also at P10 and P13.

**TABLE 5-12. P11 - Interconnect Signals**

Pin No.	Signal Name	Attribute	Description
1	SHIFT_C	I/O	LCD Shift Clock. Not used on the ADS.
2	GND	-	
3	GND	-	
4	GND	-	
5	LOE	I/O	Output Enable for TFT displays or Passive panels LCD_AC~ signal. Not used on the ADS.
6	GND	-	
7	HSYNC	I/O	Display Line beginning mark. Not used on the ADS.
8	GND	-	
9	VSYNC	I/O	New Frame beginning mark. Not used on the ADS.
10	GND	-	
11	GND	-	
12	GND	-	
13	LD0	I/O	LCD Data Line 0. Not used on the ADS.
14	GND	-	
15	LD1	I/O	LCD Data Line 1. Not used on the ADS.
16	GND	-	
17	LD2	I/O	LCD Data Line 2. Not used on the ADS.
18	GND	-	
19	LD3	I/O	LCD Data Line 3. Not used on the ADS.
20	GND	-	
21	LD4	I/O	LCD Data Line 4. Not used on the ADS.
22	GND	-	
23	LD5	I/O	LCD Data Line 5. Not used on the ADS.
24	GND	-	
25	LD6	I/O	LCD Data Line 6. Not used on the ADS.
26	GND	-	
27	LD7	I/O	LCD Data Line 7. Not used on the ADS.
28	GND	-	
29	LD8	I/O	LCD Data Line 8. Not used on the ADS.

**Support Information**

**TABLE 5-12. P11 - Interconnect Signals**

Pin No.	Signal Name	Attribute	Description
30	GND	-	

**5•1•10 P13 - QUADS Compatible Communication Connector**

The QUADS compatible Communication connector, P13 is for the benefit of those who developed communication tools for the M68360QUADS or M68360QUADS-040 boards. All SCC pins are routed to the same

ARCHIVED BY FREESCALE SEMICONDUCTOR, INC.



**Support Information**

locations as they existed on those boards. That way it is easy to migrate from the QUICC to the MPC821. P13 is a 96 pin, Female, DIN 41612 connector.

**TABLE 5-13. P13 - Interconnect Signals**

Pin No.	Signal Name	Attribute	Description
A1	ETHRX	I/O	Ethernet port Receive Data. In fact PA15/RXD1. When the Ethernet port is disabled via BCSR1, may be used off-board.
A2	ETHTX	I/O	Ethernet port Transmit Data. In fact PA14/TXD1. When the Ethernet port is disabled via BCSR1, may be used off-board for any alternate function.
A3	IRDRXD	I/O	InfraRed Port Receive Data. In fact PA13/RXD2. When the Infra-Red port is disabled, may be used off-board for any alternate function.
A4	IRDTXD	I/O	InfraRed Port Transmit Data. In fact PA12/TXD2. When the Infra-Red port is disabled via BCSR1, may be used off-board for any alternate function.
A5	LD4	I/O	MPC821's PD11/LD4 or MPC860's PD11/RXD3. Not used on the ADS. Appears also at P11 for convenient LCD connection.
A6	LD3	I/O	MPC821's PD10/LD3 or MPC860's PD10/TXD3. Not used on the ADS. Appears also at P11 for convenient LCD connection.
A7	LD2	I/O	MPC821's PD9/LD2 or MPC860's PD9/RXD4. Not used on the ADS. Appears also at P11 for convenient LCD connection.
A8	LD1	I/O	MPC821's PD8/LD1 or MPC860's PD8/TXD4. Not used on the ADS. Appears also at P11 for convenient LCD connection.
A9	ETHTCK	I/O	Ethernet Port Transmit Clock. In fact PA7/CLK1/TIN1/L1RCLKA/BRGO1. When the Ethernet port is disabled via BCSR1, may be used off-board for any alternate function. Appears also at P13.
A10	ETHRCK	I/O	Ethernet Port Receive Clock. In fact PA7/CLK2/TOUT1~/BRGCLK1. When the Ethernet port is disabled via BCSR1, may be used off-board for any alternate function. Appears also at P13.
A11	PA5	I/O	PA5/CLK3/TIN2/L1TCLKA/BRGOUT2. Not used on the ADS. Appears also at P13.
A12	PA4	I/O	PA4/CLK4/TOUT2~. Not used on the ADS. Appears also at P13.
A13	PA3	I/O	PA3/CLK5/TIN3/BRGOUT3. Not used on the ADS.
A14	PA2	I/O	PA2/CLK6/TOUT3/L1RCLKB/BRGCLK2. Not used on the ADS.
A15	PA1	I/O	PA1/CLK7/TIN4/BRGO4. Not used on the ADS.
A16	PA0	I/O	PA0/CLK8/TOUT4/L1TCLKB. Not used on the ADS.
A17	VCC	-	
A18	PA11	I/O	PA11/L1TXDB. Not used on the ADS. Appears also at P13.
A19	PA10	I/O	PA10/L1RXDB. Not used on the ADS. Appears also at P13.
A20	PA9	I/O	PA9/L1TXDA. Not used on the ADS. Appears also at P13.

**Support Information**

**TABLE 5-13. P13 - Interconnect Signals**

Pin No.	Signal Name	Attribute	Description
A21	PA8	I/O	PA8/L1RXDA. Not used on the ADS. Appears also at P13.
A22	GND	-	
A23	GND	-	
A24	IRQ7~	I, L	Interrupt Request 7. The lowest priority interrupt request line. Not used on the ADS.
A25	IRQ6~	I/O	FRZ/IRQ6~. Freeze (debug-mode) indication or Interrupt Request 6~. Configured on the ADS as IRQ6~. Not by ADS logic, may be configured to alternate function if IRQ6~ is not required.
A26	ETHEN~	O, L	Ethernet Port Enable. Connected to BCSR1. See 4•14•3 "BCSR1 - Board Control Register" on page 49.
A27	IRQ3~	I	CR~/IRQ3~. Cancel Reservation input or Interrupt Request line 3. Pulled-up but otherwise unused on the ADS.
A28	IRQ2~	I/O, L	RSV~/IRQ2~. Reservation output or Interrupt Request line 2 input. Pulled-up but otherwise unused on the ADS.
A29	IRQ1~	I, L	Interrupt Request 1. Pulled-up but otherwise not used on the ADS.
A30	NMI~	I, L	Non-Makable Interrupt. In fact IRQ0~ of the MPC. Driven by on-board logic by O.D. gate. May be driven off-board by O.D. gate only.
A31	RS_EN~	O,L	RS232 Port Enable. Connected to BCSR1. See 4•14•3 "BCSR1 - Board Control Register" on page 49.
A32	GND	-	
B1	PB31	I/O	PB31/SPISEL~/RRJECT1~. Not used on the ADS.
B2	PB30	I/O	PB30/SPICLK. Not used on the ADS.
B3	PB29	I/O	PB29/SPI MOSI. Not used on the ADS.
B4	PB28	I/O	PB28/SPI MISO/BRGO4. Not used on the ADS.
B5	PB27	I/O	PB27/I2CSDA/BRGO1. Not used on the ADS.
B6	PB26	I/O	PB26/I2CSCL/BRGO2. Not used on the ADS.
B7	RSTXD	I/O	RS232 port Transmit Data. In fact PB25/SMTXD1. When the RS232 port is disabled via BCSR1, may be used off-board for any alternate function.
B8	RSRXD	I/O	RS232 port Receive Data. In fact PB24/SMRXD1. When the RS232 port is disabled via BCSR1, may be used off-board for any alternate function.
B9	RSDTR~	I/O	RS232 port DTR~ signal. In fact PB23/SMSYN1~/SDACK1~. When the RS232 port is disabled via BCSR1, may be used off-board for any alternate function.
B10	PB22	I/O	PB22/SMSYN2~/SDACK2~. Not used on the ADS.
B11	PB21	I/O	PB21/SMTXD2/L1CLKOB. Not used on the ADS.

**Support Information**

**TABLE 5-13. P13 - Interconnect Signals**

Pin No.	Signal Name	Attribute	Description
B12	PB20	I/O	PB20/SMRXD2/L1CLKOA. Not used on the ADS.
B13	E_TENA	I/O	Ethernet port Transmit Enable. In fact PB19/RTS1~/L1ST1. When active, transmit is enabled via the MC68160 EEST. When the ethernet port is disabled via BCSR1, may be used off-board for any alternate function.
B14	PB18	I/O	PB18/RTS2~/L1ST2. Not used on the ADS.
B15	PB17	I/O	PB17/L1RQB/L1ST3. Not used on the ADS.
B16	PB16	I/O	PB16/L1RQA/L1ST4. Not used on the ADS.
B17	PB15	I/O	PB15/BRGO3. Not used on the ADS.
B18	PB14	I/O	PB14/RSTR1~. Not used on the ADS.
B19	GND	-	
B20	BINPAK~	I/O	PCMCIA port Input Port Acknowledge. In fact PC15/DREQ1~/RTS1~/L1ST1. When the PCMCIA port is disabled via BCSR1, may be used off-board for any alternate function.
B21	PC14	I/O	PC14/DREQ2~/RTS2~/L1ST2. Not used on the ADS.
B22	PC13	I/O	PC13/L1RQB/L1ST3. Not used on the ADS.
B23	PC12	I/O	PC12/L1RQA/L1ST4. Not used on the ADS.
B24	E_CLSN	I/O	Ethernet Port Collision indication signal. In fact PC11/CTS1~. When the ethernet port is disabled via BCSR1, may be used off-board for any alternate function.
B25	E_RENA	I/O	Ethernet Receive Enable. In fact PC10/CD1~/TGATE1~. Active when there is network activity. When the ethernet port is disabled via BCSR1, may be used off-board for any alternate function.
B26	PC9	I/O	PC9/CTS2~. Not used on the ADS.
B27	PC8	I/O	PC8/CD2~/TGATE2~. Not used on the ADS.
B28	PC7	I/O	PC7/L1TSYNCB/SDACK2~/CTS3~ for MPC860). Not used on the ADS.
B29	TPSQEL~	I/O	Twisted Pair Signal Quality Error Test Enable. In-fact PC6/L1RSYNCB/(CD3~ for MPC860). When active, a simulated collision state is generated within the EEST, so the collision detection circuitry within the EEST may be tested. Since after hard reset, this line wakes-up tri-stated, it should be initialized as output and given the desired value.
B30	TPFLDL~	I/O	Twisted Pair Full-Duplex. In fact PC5/L1TSYNCA/SDACK1~/CTS4~ for MPC860). When active, the MC68160 EEST is put into full-duplex mode, where, simultaneous receive and transmit are enabled. Since after hard reset, this line wakes-up tri-stated, it should be initialized as output and given the desired value.

**Support Information**

**TABLE 5-13. P13 - Interconnect Signals**

Pin No.	Signal Name	Attribute	Description
B31	ETHLOOP	I/O	Ethernet port Diagnostic Loop-Back. In fact PC4/L1RSYNCA(/CD4~ for MPC860). When active, the MC68160 EEST is configured into diagnostic Loop-Back mode, where the transmit output is internally fed back into the receive section. Since after hard reset, this line wakes-up tri-stated, it should be initialized as output and given the desired value.
B32	GND	-	
C1	VCC	-	
C2	VCC	-	
C3	VCC	-	
C4	VCC	-	
C5	VCC	-	
C6	N.C.	-	Not Connected
C7	GND	-	
C8	GND	-	
C9	GND	-	
C10	GND	-	
C11	GND	-	
C12	GND	-	
C13	GND	-	
C14	GND	-	
C15	LD8	I/O	MPC821's PD15/LD8 or MPC860's PD15/L1TSYNCA. Not used on the ADS. Appears also at P11 for convenient LCD connection.
C16	LD7	I/O	MPC821's PD14/LD7 or MPC860's PD14/L1RSYNCA. Not used on the ADS. Appears also at P11 for convenient LCD connection.
C17	LD6	I/O	MPC821's PD13/LD6 or MPC860's PD13/L1TSYNCB. Not used on the ADS. Appears also at P11 for convenient LCD connection.
C18	LD5	I/O	MPC821's PD12/LD5 or MPC860's PD12/L1RSYNCB. Not used on the ADS. Appears also at P11 for convenient LCD connection.
C19	LD0	I/O	MPC821's PD7/LD0 or MPC860's PD7/RTS3~. Not used on the ADS. Appears also at P11 for convenient LCD connection.
C20	LOE	I/O	MPC821's PD6/LCD_AC/LOE or MPC860's PD6/RTS4~. Not used on the ADS. Appears also at P11 for convenient LCD connection.
C21	VCC	-	
C22	HRESET~	I/O, L	MPC Hard Reset. Driven by on-board logic and may be driven by off-board logic with Open-Drain gate only.

**Support Information**

**TABLE 5-13. P13 - Interconnect Signals**

Pin No.	Signal Name	Attribute	Description
C23	SRESET~	I/O, L	MPC Soft Reset. Driven by on-board logic and may be driven by off-board logic with Open-Drain gate only.
C24	N.C.	-	Not Connected
C25	VCC	-	
C26	SHIFT_C	I/O	MPC821's PD3/SHIFT/CLK or MPC860's PD3/RRJECT4~. Not used on the ADS. Appears also at P11 for convenient LCD connection.
C27	VPPIN	-	+12V input for PCMCIA flash programming. Parallel to P8.
C28	VPPIN	-	+12V input for PCMCIA flash programming. Parallel to P8.
C29	GND	-	
C30	HSYNC	I/O	MPC821's PD4/LOAD/HSYNC or MPC860's PD4/RRJECT3~. Not used on the ADS. Appears also at P11 for convenient LCD connection.
C31	GND	-	
C32	VSYNC	I/O	MPC821's PD5/FRAME/VSYNC or MPC860's PD5/RRJECT2~. Not used on the ADS. Appears also at P11 for convenient LCD connection.

**5•2 MPC821ADS Part List**

In this section the MPC821ADS's bill of material is listed according to their reference designation.

**TABLE 5-14. MPC821ADS Part List**

Reference Designation	Part Description	Manufacturer	Part #
C1 C4 C5 C8 C10 C12 C14 C16 C19 C21 C22 C23 C24 C25 C26 C27 C28 C29 C30 C32 C33 C34 C35 C36 C38 C39 C40 C41 C42 C45 C46 C47 C48 C49 C50 C51 C52 C53 C54 C56 C57 C58 C59 C60 C62 C63 C64 C65 C66 C67 C68 C69 C70 C71 C72 C73 C74 C76 C77 C78 C81 C82 C83 C84 C87 C88 C89 C93 C94 C95 C96 C99	Capacitor 0.1μF SMD 1206 Ceramic	SIEMENS	B37872-K5104K
C2	Capacitor 10nF, 50V, 10%, NPO, SMD 1210, Ceramic	VITRAMNON	VJ1210A103KXAT

**Support Information**

**TABLE 5-14. MPC821ADS Part List**

Reference Designation	Part Description	Manufacturer	Part #
C3	Capacitor 4.7 $\mu$ F, 20V, 10%, SMD Size B, Tantalum	SIEMENS	B45196-H4106-K30
C6 C13 C15 C17 C18 C90 C91 C98	Capacitor 10 $\mu$ F, 20V, 10%, SMD Size C, Tantalum	SIEMENS	B45196-H4475-K20
C7	Capacitor 100pF, 50V, 10%, SMD 1206, Ceramic	SIEMENS	B37871-K5101K
C9 C11 C55 C97	Capacitor 100 $\mu$ F, 10V, 10%, SMD Size D, Tantalum	SIEMENS	B45196-H2107-K10
C20 C61 C80 C92	Capacitor 1 $\mu$ F, 25V, 10%, SMD Size A, Tantalum	SIEMENS	B45196-H5105-K10
C31 C37	Capacitor 68pF, 50V, 5%, SMD 1206, Ceramic	SIEMENS	B37871-K5680J
C43	Capacitor 3900pF, 50V, 5%, COG, SMD 1210 Ceramic	SIEMENS	B37949-K5392J
C44	Capacitor 0.039 $\mu$ F, 50V, 5%, SMD 1206, Ceramic	SIEMENS	B37872-K5393J
C75 C79	Capacitor 10pF, 50V 10%, COG, SMD 1206, Ceramic	AVX	AV12065A100KAT00J
C85	Capacitor 5000pF, 50V, 10%, SMD 1206, Ceramic	AVX	AV12065C 502K A700J
C86	Capacitor 0.68 $\mu$ F, 20V, 10%, SMD, Size A, Tantalum	SIEMENS	B45196-E4684-K9
D1 D2 D3 D4	Diode SMD	Motorola	LL4004G
D5	Zener Diode, 5V SMD	Motorola	1SMC5.0AT3
D6 D7	Diode Pair, common cathode	Motorola	MBRD620CT
D8	Zener Diode, 12V SMD	Motorola	1SMC12AT3
DS1 DS2	Dip-Switch, 4 X SPST, SMD	GRAYHILL	90HBW04S
F1	Fuse, 5A/250V Miniature 5 X 20mm, Fast-blow		
F2	Fuse, 1A/250V Miniature 5 X 20mm, Fast-blow		
H1 H2 H3 H4	Gnd Bridge, Gold Plated	PRECIDIP	999-11-112-10
J1 J2 J3	Jumper Header, 3 Pole with Fabricated Jumper		
J4	Jumper, Soldered.		
L1	Inductor 8.2 mH	BOURNS	PT12133
LD1 LD5 LD6 LD14 LD15	Led Green SMD	SIEMENS	LG T670-HK

**Support Information**

**TABLE 5-14. MPC821ADS Part List**

Reference Designation	Part Description	Manufacturer	Part #
LD2 LD3 LD4 LD8 LD11 LD12 LD13	Led Yellow SMD	SIEMENS	LY T670-HK
LD7 LD9 LD10	Led Red SMD	SIEMENS	LS T670-HK
P1	Connector 37 pin, Male DType, 90°	KCC	DN-37-P-RCZ
P2	Connector 8 pin, RJ45 Receptacle, 90°	KCC	90015-8P8C
P3	Connector 9 pin, Female, DType, 90°	KCC	DN-09-S-RCZ
P4	Connector 68 pin, Male, SMD, PCMCIA.	MOLEX	53380-6810
P5	Connector header, 10 pin, dual in-line, SMD	SAMTEC	TSM-105-03-S-DV
P6	Connector Header, 2 X 60 pin, Quad In-line, SMD.	SAMTEC	TSM-130-3-S-DV-A-P
P7 (Male Part)	Connector 3 pin, Power, Straight, with false insertion protection.	WB	8113S-253303353
P7 (Female Part)	Connector 3 pin, Power Plug	WB	8113B-253200353
P8 (Male Part)	Connector 2 pin, Power, Straight, with false insertion protection.	WB	8113S-253303253
P8 (Female Part)	Connector 2 pin, Power Plug	WB	8113B-253200253
P9 P10 P12	Connector Header 2 X 50 pin, Quad In-line, SMD	SAMTEC	TSM-125-03-S-DV-A-P
P11	Connector Header, 30 pin, Dual In-line, SMD	SAMTEC	TSM-115-03-S-DV
P13	Connector 96 pin, Female, DIN 41612, 90°	ELCO	268477096002025
P13 Counterpart	Connector 96 pin, Male, DIN 41612, 90°, WW	ELCO	168457096004025
R1 R2 R3 R4 R5 R16 R17 R18 R19 R20 R27 R36 R38 R41 R42 R43 R44 R46 R48 R49 R50 R51 R52 R57 R58 R63 R64 R73 R74 R77 R78 R79 R80	Resistor 10 K $\Omega$ , 1%, SMD 1206, 1/8W	RODERSTEIN	D25 010K FC5
R6	Resistor 10 $\Omega$ , 1%, SMD 1206, 1/8W	RODERSTEIN	D25 10R FCS
R7 R15	Resistor 2 k $\Omega$ , 1%, SMD 1206, 1/8W	BOURNS	CR1206 FX 2001E
R8 R13 R21 R53	Resistor 100 $\Omega$ , 1%, SMD 1206, 1/8W	RODERSTEIN	D25 100R FCS

**Support Information**

**TABLE 5-14. MPC821ADS Part List**

Reference Designation	Part Description	Manufacturer	Part #
R9	Resistor 5.1 K $\Omega$ , 1%, SMD 1206, 1/8W	RODERSTEIN	D25 5K1 FCS
R10 R12	Resistor 47 K $\Omega$ , 1%, SMD 1206, 1/8W	KYOCERA	CR32 473JT
R11 R14 R26 R32 R39 R45 R47 R61 R62	Resistor 150 $\Omega$ , 5% SMD 1206, 1/8W	BOURNS	CR1206 JW 151 E
R22 R23	Resistor 39.1 $\Omega$ , 1%, SMD 1206, 1/8W	TYOHM	RMC 12061/8W 39E
R24 R31 R37	Resistor 22 $\Omega$ , 5%, SMD 1206, 1/8W	RODERSTEIN	D25 24R FCS
R25 R54 R66 R69 R75 R76	Resistor 1 K $\Omega$ , 5%, SMD 1206, 1/8W	AVX	CR32 102F T
R28 R71	Resistor 243 $\Omega$ , 1%, SMD 1206, 1/8W	RODERSTEIN	D25 243R FCS
R29 R30 R33 R34 R35	Resistor 330 $\Omega$ , 5%, SMD 1206, 1/8W	RODERSTEIN	D25 332R FC5
R40	Resistor 294 $\Omega$ , 1%, SMD 1206, 1/8W	TYOHM	RMC 1206 294E 1%
R55 <sup>a</sup> R56 <sup>a</sup> R59 <sup>a</sup> R70	Resistor 124 K $\Omega$ , 5%, SMD 1206, 1/8W	RODERSTEIN	D25 124K FCS
R60	Resistor 510 $\Omega$ , 1%, SMD 1206, 1/8W	BOURNS	CR1206 JW 472E
R65	Resistor 20 M $\Omega$ , 5%, SMD 1206, 1/8W	RODERSTEIN	D25 020MJS
R67	Resistor 0 $\Omega$ , SMD 1206, 1/8W	TYOHM	RMC 1206 0E 1%
R68	Resistor 200 K $\Omega$ , 5%, SMD 1206, 1/8W	RODERSTEIN	D25 200K FCS
R72	Resistor 143 $\Omega$ , 5%, SMD 1206, 1/8W	RODERSTEIN	D25 143R FCS
RN1 RN2 RN4 RN5 RN6 RN7	Resistor Network 10 K $\Omega$ , 5%, 13 resistors, 14 pin	DALE	SOMC 14 01 103J
RN3	Resistor Network 22 $\Omega$ , 5%, 8 resistors, 16 pin.	DALE	SOMC 16 03 220J
SK1	Speaker piezo, Sealed	SOUNDTECH	SEP-1162
SW1	SPDT, push button, RED, Sealed	C & K	KS12R22-CQE
SW2	SPDT, push button, BLACK, Sealed	C & K	KS12R23-CQE
T1 T2 T3	Transistor TMOS, Dual, 3A	Motorola	M MDF3N03HD
U1	Infra-Red Transceiver	Telefunken	TFDS3000



**Support Information**

**TABLE 5-14. MPC821ADS Part List**

Reference Designation	Part Description	Manufacturer	Part #	
U2	Buffer Schmitt-Trigger	Motorola	MC74LS244D	
U3	10 Base-T Filter network	Pulse Engineering	PE-68026	
U4	RS232 Transceiver (3 X 3)	Motorola	MC145707DW	
U5	Voltage level detector. Range 2.595V to 2.805V. O.D. output.	Seiko	S-8052ANY-NH-X	
U6	Schmitt-Trigger Hex Inverter.	Motorola	74ACT14D	
U7 U10 U11	MACH220 - programmable logic device	AMD	MACH220-12JC	
U8	Clock generator 20MHz, ±100ppM, 5V, HCMOS output, SMD	Jauch	VX-3A	
U9	Enhanced Ethernet Serial Transceiver.	Motorola	MC68160FB	
U12	Dual Channel PCMCIA Power Controller	Linear Technology	LTC1315cG	
U13 U19 U24 U29 U30 U32 U33 U34 U35 U37	Octal CMOS Buffer.	Motorola	74ACT541D	
U14 U27 U28 U31	Octal CMOS Latch.	Motorola	74ACT373D	
U15	2 MByte Flash SIMM.	Motorola	MCM29020	
U16	4 MByte DRAM SIMM organized as 1 M X 4. 70 nsec delay	Motorola	MCM36100-70	
U17	4 MHz Clock generator. 3.3V, CMOS levels.	MGR-Tech	MH14FAD 3.3V 4.00MHz	
U18	MPC821, 19 X 19 BGA.	Motorola	PPC821ZP25 PPC821ZP40 PPC821ZP50	or or
U20	Variable Output Voltage regulator.	Motorola	LM317MDT	
U21	3.3V Voltage regulator. 1.5A output.	Linear	LT1086	
U22	Quad CMOS buffer with individual Output Enable.	Motorola	74ACT125D	
U23	Schmitt-Trigger Hex Inverter.	Motorola	74AC14D	
U25 U26 U39 U40 U41 U42	Octal CMOS Bus Transceiver	Motorola	74ACT245D	
U36	Voltage level detector. Range 1.795V to 2.005V. O.D. output.	Seiko	S-8051HN-CD-X	
U38	Dual CMOS 4 -> 1 MUX	Motorola	74ACT158D	
UA38	Quad CMOS AND Gate.	Motorola	74AC08D	

**Support Information**

**TABLE 5-14. MPC821ADS Part List**

Reference Designation	Part Description	Manufacturer	Part #
Y1	Crystal resonator, 20 MHz, Fundamental Oscillation mode, Frequency tolerance $\pm 50$ ppm, Drive-level - 1mW $\pm 0.2$ mW, Shunt capacitance - 7pF Max., Load capacitance - 32pF, Equivalent Series Resistance - 50 $\Omega$ Max. Insulation Resistance - 500 M $\Omega$ at 100 VDC.	MEC - Modern Enterprise Corporation	HC-49/U-SM-3
Y2	Crystal resonator, 32.768 KHz, Frequency tolerance $\pm 30$ ppm, Drive-level - 10 $\mu$ W Max, Shunt capacitance - 2pF Max., Load capacitance - 12.5pF Max., Equivalent Series Resistance - 35 K $\Omega$ Max.	RALTRON	RSM-200-32.768 KHZ
	3 X Socket 68 Pin PLCC.	AMP	822279-1
	14 pin PC Socket	PD	110-93-314
	72 pin SIMM Socket	AMP	822032-4
	80 pin SIMM Socket	AMP	822032-5
	357 pin 19 X 19 BGA Socket	3M	2-0357-08268-000-019-002

a. Not Assembled.

Freescale Semiconductor, Inc.

ARCHIVED BY FREESCALE SEMICONDUCTOR, INC.

**Support Information**

**APPENDIX A - Programmable Logic Equations**

The MPC821ADS has 3 programmable logic devices on it. Use is done with MACH220-12 by AMD. These device support the following function on the ADS:

- 1) U7 - Debug Port Controller
- 2) U10 - auxiliary board control functions, e.g., buffers control, local interrupter, reset logic, etc.
- 3) U11 - the BCSR.

ARCHIVED BY FREESCALE SEMICONDUCTOR, INC.

Support Information

**A•1** U7 - Debug Port Controller

```
*****
"* Pda ADS Debug Port Controller.                                     *
"* Mach controller for an interface between Sun ADI port at one side, to *
"* debug port at the other.                                         *
*****
"* In this file (6):
"* - RUN signal polarity was changed to active-high, this, to support
"*   other changes for revision PILOT of the ads.
*****
"* In this file (5) added:
"* - protection against spikes on the reset lines, so that the interface
"*   will not be reset by an accidental spike.
"* - D_C~ signal was synchronized to avoid accidental write to control
"*   during data write.
"* - DSDI is given value (H) prior to negation of SRESET* to comply with 5XX
"*   family
*****
"* In this file (4) the polarity of address selection lines is reversed so
"* that ON the switch represent address line at high and vice-versa
*****
"* In this file (3) the Clk2 is not reset at all so it can be used to
"* sync pda reset signals inside.
"* Added consideration for reset generated by the pda:
"* - when pda is reset (i.e., its hard | soft reset signals are asserted,
"*   it is not allowed for the host to initiate data transfer towards the pda.
"*   It can however, access the control / status register to either change
"*   parameters and / or check for status.
"* - The status of reset signals is added to the status register, so it can
"*   be polled by the host.
*****

module dbg_prt6
title 'MPC821ADS Debug Port Controller.'

*****
"* Device declaration.                                             *
*****

U07 device 'mach220a';
```



### Support Information

```
AdsAddr0,
AdsAddr1,
AdsAddr2          PIN 7, 6, 5; "ADS board address switch. (IN)

AdsSelect~       NODE ISTYPE 'com, buffer'; "ADS selection indicator. (OUT)

*****
* PDA pins. Including debug port.
*****
PdaHardReset~    PIN 40;          "Pda's hard reset input. (I/O. o.d.)
PdaSoftReset~    PIN 65;          "Pda's soft reset output. (I/O. o.d.)
VFLS0, VFLS1     PIN 10, 11;      "Debug/Trap mode, report. (IN)
DSCK              PIN 48 istype 'com'; "Pda's debug port clock. (Out)
DSDI              PIN 47 istype 'com'; "Pda's debug serial data in (Out)
DSDO              PIN 4;          " Pda's debug serial data output (In)
*****
* Mach to ADI data bus.
*****
PD7,
PD6,
PD5,
PD4,
PD3,
PD2,
PD1,
PD0              PIN 66,60,67,59,58,57,56,55; "ADI data bus.(I/O)
*****
* Clock gen pins.
*****
SYSCLK           PIN 15;          "System clock. (IN)
Clkout2          PIN 12 istype 'reg, buffer'; "System clock divided by 2
Clk4             PIN 14 istype 'reg, buffer'; "System clock divided by 4 (Out)
                " (Out for testing, may be node)
Clk2             PIN 16;          " Connected to Clkout externally (In)
*****
* Misc.
*****
Run              PIN 23 istype 'com'; "external indication
```

Support Information

```

*****
"*   ###                               *
"*   #   #   #   #####   #####   #####   #   #   ##   #   #####   *
"*   #   ##   #   #   #   #   #   #   #   #   #   #   #   #   #   *
"*   #   #   #   #   #   #####   #   #   #   #   #   #   #   #   #   *
"*   #   #   #   #   #   #   #   #####   #   #   #   #####   #   #   *
"*   #   #   ##   #   #   #   #   #   #   #   ##   #   #   #   #   #   *
"*   ###   #   #   #   #####   #   #   #   #   #   #   #   #####   #####   *
*****

*****
"* Reset active. (Active when at least one of the reset sources is active)   *
*****

PrimReset           NODE istype 'com';          " Primary Reset. Host initiated
D_PrimReset         NODE istype 'com';          " delayed Reset
DD_PrimReset        NODE istype 'com';          " double delayed primary reset.

Reset               NODE istype 'com';          " Interface reset.
PdaRst              NODE istype 'reg, buffer';  " pda continued / initiated.
                  " part of the status register.

*****
"* ADS_ACK, ADS_REQ auxiliary internal control signals                       *
*****

S_HstReq            NODE istype 'reg';          "sync. host req.
DS_HstReq           NODE istype 'reg';          " double sync. host req.

S_D_C~              NODE istype 'reg, buffer'; " synchronized data/ control selection

S_HstAck            NODE istype 'reg, buffer'; " sync host ack
DS_HstAck           NODE istype 'reg, buffer'; " double sync host ack

BundleDelay1,
BundleDelay0        NODE istype 'reg, buffer'; "delay counter for bundle
                  " delay compensation
BndTmrExp           NODE istype 'com';          " terminal count for bundle
                  " delay timer.
PDOe                NODE istype 'com';          "Mach to ADI data OE.
    
```

### Support Information

```
PdaHardResetEn    NODE istype 'com';    " enables hard reset buffer.
PdaSoftResetEn    NODE istype 'com';    " enables soft reset buffer.

*****
"* Tx Shift Register                                     *
*****

TxReg7,
TxReg6,
TxReg5,
TxReg4,
TxReg3,
TxReg2,
TxReg1,
TxReg0            NODE istype 'reg, buffer'; " Transmit latch and
                  " shift register

*****
"* Tx Control Logic                                     *
*****

TxWordLen3,
TxWordLen2,
TxWordLen1,
TxWordLen0        NODE istype 'reg, buffer'; " Counter, counts (on fast clock,
                  " to gain 1/2 clock resolution)
                  " transmission length

TxWordEnd          NODE istype 'com';        " Terminal count, sets transmission
                  " length.

TxEn               NODE istype 'reg, buffer'; " Transmit Enable.
TxClkSns           NODE istype 'reg, buffer'; " transmit clock polarity

*****
"* Rx Shift Register                                     *
*****

RxReg0            NODE istype 'reg, buffer'; " receive shift register
                  " and latch

*****
"* Rx Control Logic                                     *
*****

Dsdien             NODE istype 'reg';        " enables dsdi towards
```



**Support Information**

```

*****
* ADI control & status register bits.
*****

StatusRequest~    NODE istype 'reg, buffer';    "Status request
DebugEntry~       NODE istype 'reg, buffer';    "Debug enable after reset (L)
DiagLoopBack~    NODE istype 'reg, buffer';    "diagnostic loopback mode (L)
Delay1~,
Delay0~           NODE istype 'reg, buffer';    " bundle delay field (L)
InDebugMode       NODE istype 'reg, buffer';    " sync. VFLSs, became pin
TxError           NODE istype 'reg, buffer';    " tx interrupted by pda
                " internal reset.

*****
* #####
* # # ##### # # ##### ##### ## # # #####
* # # # # # # # # # # # # # # # # #
* # # # # # # # # # # # # # # # # # # # #
* # # # # # # # # # # # # # # # # # # # #
* # # # # # # # # # # # # # # # # # # # #
* ##### ##### # # ##### # # # # # # # #
*
* #####
* # # ##### ##### # ## #####
* # # # # # # # # # # # # # #
* # # ##### # # # # # # # # # # # # # #
* # # # # # # # # # # # # # # # # # # # #
* # # # # # # # # # # # # # # # # # # # #
* ##### ##### ##### ##### # # # # # # # #
*
* ## ##### # ##### # #
* # # # # # # # # # # # # # #
* # # # # # # # # # # # # # # # # # # # #
* ##### # # # # # # # # # #
* # # # # # # # # # # # # # # # # # # # #
* # # # # # # # # # # # # # # # # # # # #
*****

H, L, X, Z = 1, 0, .X., .Z.;
C, D, U = .C., .D., .U.;

```

Freescale Semiconductor, Inc.

## Support Information

```
*****
"* Since all state machines operate at 1/2 system clock (Clk2) there is no
"* need to have SYSCLK driven during simulation (it will double the number
"* of vectors required). Therefore, an alternative clock generator was built
"* with which the 1/2 clock is the 1'st in the chain.
"* This alternative clock is compiled in if the SIMULATION variable is defined.
"* If not the original clock generator design is compiled, however simulation
"* will not pass then.
*****
SIMULATION = 1;
*****

*****
"* Signal groups
*****
AdsSel      = [AdsSel2,AdsSel1,AdsSel0];
AdsAddr     = [!AdsAddr2,!AdsAddr1,!AdsAddr0];

AdsRst      = [AdsHardReset, AdsSoftReset];
Rst         = [PdaHardReset~, PdaSoftReset~];

ClkOut      = [Clkout2, Clk4];

PD          = [PD7,PD6,PD5,PD4,PD3,PD2,PD1,PD0];
VFLS       = [VFLS0, VFLS1];
BndDly     = [BundleDelay1, BundleDelay0]; "bundle delay
                                                "compensation timer

TxReg      = [TxReg7..TxReg0];
RxReg      = [TxReg6,TxReg5,TxReg4,TxReg3,TxReg2,TxReg1,TxReg0,RxReg0];
AdiCtrlReg = [Delay1~, Delay0~, StatusRequest~, DiagLoopBack~,
                                                DebugEntry~];
AdiStatReg = [PdaRst, TxError, InDebugMode, Delay1~, Delay0~,
              StatusRequest~, DiagLoopBack~, DebugEntry~];
BundleDelayField = [Delay1~, Delay0~];
TxWordLen   = [TxWordLen3, TxWordLen2, TxWordLen1, TxWordLen0];
PortEn      = [AdsSel2,AdsSel1,AdsSel0,!AdsAddr2,!AdsAddr1,!AdsAddr0,
                                                HostVcc,HstEn~];
*****
"* Select Logic definitions
*****
```

### Support Information

```
HOST_VCC_ACTIVE = 1;
HOST_EN~_ACTIVE = 0;

HOST_IS_ON = ((HstEn~==HOST_EN~_ACTIVE) & (HostVcc==HOST_VCC_ACTIVE));
HOST_IS_OFF = !HOST_IS_ON;
```

```
BOARD_IS_SELECTED = 0;
ADS_IS_SELECTED = (AdsSelect~.fb==BOARD_IS_SELECTED) ;
```

```
"Data_Cntrl~ line levels.
DATA = 1;
CONTROL = !DATA;
```

```
*****
```

```
"* Reset Logic definitions
```

```
*****
```

```
ADS_HARD_RESET_ACTIVE = 1;
ADS_SOFT_RESET_ACTIVE = 1;
```

```
*****
```

```
"* AdsAck Logic definitions
```

```
*****
```

```
HOST_REQ_ACTIVE = 1;
ADS_ACK_ACTIVE = 1; "The other state is - !ADS_ACK_ACTIVE
HOST_ACK_ACTIVE = 1;
```

```
HOST_WRITE_ADI = ( (AdsSelect~.fb==BOARD_IS_SELECTED) &
                   (DS_HstReq.fb ==HOST_REQ_ACTIVE) &
                   (AdsAck==!ADS_ACK_ACTIVE) &
                   (HstAck==!HOST_ACK_ACTIVE) );
```

```
HOST_WRITE_ADI_CONTROL = ( (AdsSelect~.fb==BOARD_IS_SELECTED) &
                             (DS_HstReq.fb ==HOST_REQ_ACTIVE) &
                             (AdsAck==!ADS_ACK_ACTIVE) &
                             (D_C~==CONTROL) &
                             (S_D_C~.fb == CONTROL) &
                             (HstAck==!HOST_ACK_ACTIVE) );
```

### Support Information

```
HOST_WRITE_ADI_DATA      = ( (AdsSelect~.fb==BOARD_IS_SELECTED) &
                             (DS_HstReq.fb==HOST_REQ_ACTIVE) &
                             (AdsAck==!ADS_ACK_ACTIVE) &
                             (D_C~==DATA) &
                             (S_D_C~.fb ==DATA) &
                             (HstAck==!HOST_ACK_ACTIVE) );
```

```
HOST_WRITE_COMPLETE      = ( (AdsSelect~.fb==BOARD_IS_SELECTED) &
                             (DS_HstReq.fb==!HOST_REQ_ACTIVE) &
                             (AdsAck==!ADS_ACK_ACTIVE) );
```

```
*****
```

```
"* Control & Status register definitions
```

```
*****
```

```
STATUS_REQUEST= 0;
DEBUG_ENTRY= 0;
DIAG_LOOP_BACK= 0;
IN_DEBUG_MODE  = 1;
```

```
TX_DONE_OK= 0;
TX_INTERRUPTED = !TX_DONE_OK;
```

```
IS_STATUS_REQUEST = (StatusRequest~.fb == STATUS_REQUEST);
DEBUG_MODE_ENTRY  = (DebugEntry~.fb == DEBUG_ENTRY);
IN_DIAG_LOOP_BACK = (DiagLoopBack~.fb == DIAG_LOOP_BACK);
IS_IN_DEBUG_MODE  = (InDebugMode.fb == IN_DEBUG_MODE);
```

```
*****
```

```
"* DSDI_ENABLE Logic definitions
```

```
*****
```

```
DSDI_ENABLED = 1;
DSDI_DISABLED = 0;
```

```
STATE_DSDI_ENABLED = (Dsdien.fb == DSDI_ENABLED);
```

### Support Information

```
*****
"* Tx enable state machine
*****
TX_ENABLED = 1;
TX_DISABLED = 0;

STATE_TX_ENABLED = (TxEn.fb == TX_ENABLED);
STATE_TX_DISABLED = (TxEn.fb == TX_DISABLED);

TX_WORD_LENGTH = 14; " In 1/2 Clk2 clocks

*****
"* TxClkSns state machine
*****
TX_ON_RISING = 0;
TX_ON_FALLING = 1;

STATE_TX_ON_RISING = (TxClkSns.fb == TX_ON_RISING);
STATE_TX_ON_FALLING = (TxClkSns.fb == TX_ON_FALLING);
*****
"* AdsReq machine definitions.
*****
ADS_REQ_ACTIVE = 1; "The other state is - !ADS_REQ_ACTIVE

HOST_READ_ADI = ( (AdsSelect~.fb==BOARD_IS_SELECTED) &
                  (DS_HstAck.fb==HOST_ACK_ACTIVE) &
                  (AdsReq==ADS_REQ_ACTIVE) &
                  (HstReq==!HOST_REQ_ACTIVE) );

HOST_READ_ADI_DATA = ( (AdsSelect~.fb==BOARD_IS_SELECTED) &
                       (DS_HstAck.fb==HOST_ACK_ACTIVE) &
                       (HstReq==!HOST_REQ_ACTIVE) &
                       (AdsReq==ADS_REQ_ACTIVE) &
                       (D_C~==DATA) );

HOST_READ_ADI_CONTROL = ( (AdsSelect~.fb==BOARD_IS_SELECTED) &
                           (DS_HstAck.fb==HOST_ACK_ACTIVE) &
                           (HstReq==!HOST_REQ_ACTIVE) &
                           (AdsReq==ADS_REQ_ACTIVE) &
                           (D_C~==CONTROL) );
```

**Support Information**

```

ADS_SEND_STATUS    = ( (AdsSelect~.fb==BOARD_IS_SELECTED) &
                      (DS_HstReq.fb == !HOST_REQ_ACTIVE) &
                      (D_C~==CONTROL) &
                      (AdsAck==ADS_ACK_ACTIVE) &
                      IS_STATUS_REQUEST );
    
```

\*\*\*\*\*

\* ADI Data Bus definitions

\*\*\*\*\*

```

DATA_BUFFERS_ENABLE = ( (AdsSelect~.fb==BOARD_IS_SELECTED) &
                      (HstAck==HOST_ACK_ACTIVE) &
                      (HstReq==!HOST_REQ_ACTIVE) );
    
```

```

STATUS_WORD_ON_ADI_BUS = ( (AdsSelect~.fb==BOARD_IS_SELECTED) &
                          (HstAck==HOST_ACK_ACTIVE) &
                          (HstReq==!HOST_REQ_ACTIVE) &
                          (D_C~==CONTROL) );
    
```

```

READ_DATA_WORD_ON_ADI_BUS = ( (AdsSelect~.fb==BOARD_IS_SELECTED) &
                              (HstAck==HOST_ACK_ACTIVE) &
                              (HstReq==!HOST_REQ_ACTIVE) &
                              (D_C~== DATA) );
    
```

\*\*\*\*\*

\* Equations, state diagrams. \*

\*\*\*\*\*

\* \*

\* ##### \*

\* # ##### # # ## ##### # ##### # # # # # # # # # # \*

\* # \*

\* ##### \*

\* # \*

\* ##### \*

\* \*

\*\*\*\*\*

\*\*\*\*\*

Freescale Semiconductor, Inc.

## Support Information

```
*****
"* AdsSelect.
"* ADS selection indicator. At low state, when host accesses the ADS.
*****
equations

!AdsSelect~ = HOST_IS_ON & (AdsSel==AdsAddr); "AdsAddr is already inverted

*****
"* Internal Logic Reset.
*****
equations

PrimReset = HOST_IS_OFF # "internal logic reset
            ( (AdsHardReset == ADS_HARD_RESET_ACTIVE) &
              (AdsSoftReset ==ADS_SOFT_RESET_ACTIVE) &
              ADS_IS_SELECTED );

D_PrimReset = PrimReset.fb;
DD_PrimReset = D_PrimReset.fb;

Reset = PrimReset.fb & D_PrimReset.fb & DD_PrimReset.fb;" spike filter

"* reset status

PdaRst.clk = Clk2;

PdaRst := (!PdaHardReset~ # !PdaSoftReset~) &
          (AdsSelect~.fb==BOARD_IS_SELECTED); " synchronized inside.

*****
"* Reset PDA. (Connected to PDA hard and reset inputs) Asynchronous.
*****
equations

!PdaHardReset~ = H;

PdaHardReset~.oe = PdaHardResetEn; "open-drain
```

### Support Information

```
PdaHardResetEn = ADS_IS_SELECTED &  
                (AdsHardReset==ADS_HARD_RESET_ACTIVE);
```

```
!PdaSoftReset~ = H;
```

```
PdaSoftReset~.oe = PdaSoftResetEn; "needs to be open-drain
```

```
PdaSoftResetEn = ADS_IS_SELECTED &  
                (AdsSoftReset==ADS_SOFT_RESET_ACTIVE );
```

```
*****  
* Clock generator. Divides the system clock and generates 2 clocks.  
* 1) Clkout2 which is used for all state machines. (connected to Clk2)  
* 2) Clk4 which is used to generate DSCK and for shift registers' control.  
*****
```

```
@ifndef SIMULATION {
```

```
equations
```

```
ClkOut.clk = SYSCLK;
```

```
ClkOut.oe = ^h3;
```

```
Clkout2 := !Clkout2 & HOST_IS_ON; "divide by 2
```

```
Clk4 := (Clkout2 !$ Clk4) & HOST_IS_ON; "divide by 4
```

```
}
```

```
*****  
* For simulation purpose only Clk4 is generated using Clk2 only. (no use of  
* sysclk)  
*****
```

```
@ifdef SIMULATION {
```

```
equations
```

```
Clkout2.clk = SYSCLK;
```

```
Clkout2 := !Clkout2 & HOST_IS_ON; "divide by 2
```



### Support Information

```
Clk4.clk = Clk2;
ClkOut.oe = 3;
ClkOut.ar = Reset;

Clk4 := !Clk4 & HOST_IS_ON;          "divide by 2
}

*****
* Bundle delay timer. This timer ensures data validity in the following cases:
* 1) Host write to adi. In that case AdsAck is ASSERTED only after that timer
*   expired.
* 2) Host read from adi. In that case AdsReq is NEGATED after that timer
*   expired, ensuring enough time for data propagation over the bundle.
* The timer is async reset when both soft and hard reset is applied to the i/f.
* The timer is sync. reset a clock after it expires.
* Count starts when either HstReq or HstAck are detected asserted
* (after proper synchronization)
* The value upon which the terminal count is asserted, is in the control
* register. When the interface is reset by the host, this value defaults
* to its upper bound. Using the diagnostic loop-back mode this value
* may be re-established for optimal performance. (by means of test & error)
*****

equations

BndDly.ar = Reset;
BndDly.clk = Clk2;

when ( ( (HOST_WRITE_ADI_CONTROL # HOST_READ_ADI_CONTROL ) #
        (HOST_WRITE_ADI_DATA # HOST_READ_ADI_DATA) & !PdaRst.fb)
        & !BndTmrExp.fb) then
    BndDly := BndDly.fb +1;
else
    BndDly := 0;

BndTmrExp = (BndDly.fb == (3 - BundleDelayField.fb)) & !AdsAck ;  "delay field
                                                    "active low.
```

**Support Information**

```

*****
"* AdsAck.
"* Host write to ads ack. This state machine generates an automatic ADS_ACK,
"* during a host to ADS write.
"* When the host access the ADS data / control register, an automatic
"* acknowledge is generated, after data has been latched into either the
"* tx shift register or the control register.
"* Acknowledge is released when the host removes its write control line.
"* (HstReq)
"* The machine steps through these states :
"* 0 - !ADS_ACK_ACTIVE
"* 1 - ADS_ACK_ACTIVE
*****

```

equations

```

AdsAck.clk = Clk2;
AdsAck.ar = Reset;
AdsAck.oe = ADS_IS_SELECTED;

S_HstReq.clk = Clk2;
DS_HstReq.clk = Clk2;

S_HstReq := HstReq;
DS_HstReq := S_HstReq.fb & HstReq;"double synced

S_D_C~.clk = Clk2;" synchronizing D_C~ selector
S_D_C~ := D_C~;

```

state\_diagram AdsAck

```

state !ADS_ACK_ACTIVE:
    if ( (HOST_WRITE_ADI_CONTROL #
        (HOST_WRITE_ADI_DATA & !PdaRst.fb) ) & BndTmrExp.fb) then
        ADS_ACK_ACTIVE
    else
        !ADS_ACK_ACTIVE;

state ADS_ACK_ACTIVE:
    if ( DS_HstReq.fb==!HOST_REQ_ACTIVE ) then
        !ADS_ACK_ACTIVE
    else
        ADS_ACK_ACTIVE;

```

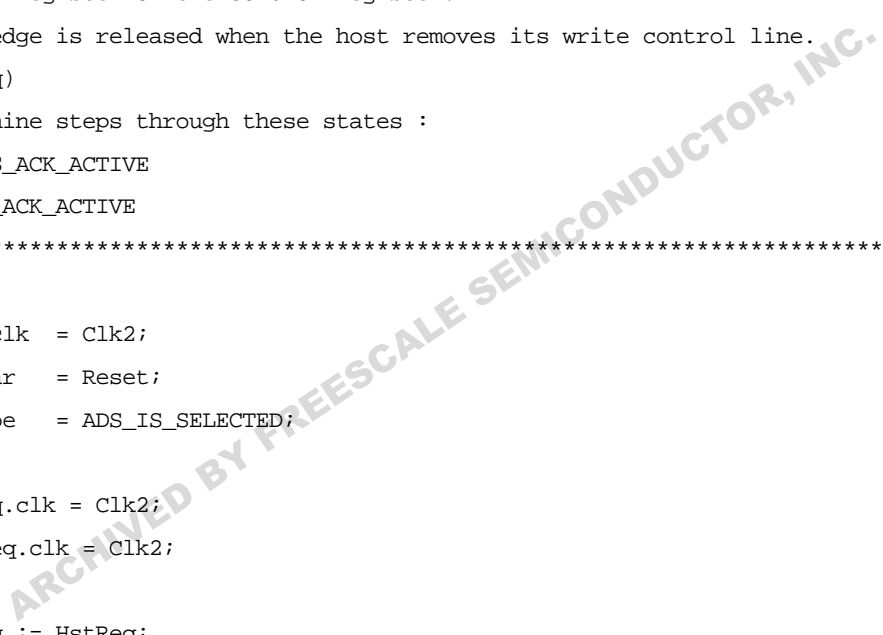

**Support Information**

```
*****
"* Transmit Enable logic.
"* Enables transmit of serial data over DSDI and generation of serial
"* clock over DSCK.
"* Transmission begins immediately after data written by the host is latched
"* into the transmit shift register and ends after 7 shifts were made to the
"* tx shift register.
"* Termination is done using a 4 bit counter TxWordLength which has a terminal
"* count (and reset) TxWordEnd.
*****
```

equations

```
TxEn.ar = Reset;
TxEn.clk = Clk2;" to provide 1/2 clock resolution
```

state\_diagram TxEn

```
state TX_DISABLED:
    if(HOST_WRITE_ADI_DATA & BndTmrExp.fb & !PdaRst.fb) then
        TX_ENABLED
    else
        TX_DISABLED;
state TX_ENABLED:
    if(TxWordEnd # PdaRst.fb) then
        TX_DISABLED
    else
        TX_ENABLED;
```

```
*****
"* Transmit Length Counter. This counter determines the length of transmission
"* towards the MPC. The fast clock is used here to allow 1/2 clock resolution
"* with the negation of TxEn, which enables DSCK outside.
*****
```

equations

```
TxWordLen.ar = Reset;
TxWordLen.clk = Clk2;
```

```
TxWordEnd = (TxWordLen.fb == TX_WORD_LENGTH);
```

```
when ( STATE_TX_ENABLED & !TxWordEnd & !PdaRst.fb) then
```

```
    TxWordLen.d = TxWordLen.fb + 1;
```

```
else
```

```
    TxWordLen.d = 0;
```

## Support Information

```
*****
"* TxClkSns - Transmit Clock Sense.
"* Since Host req is synced acc to Clk2 and may be detected active when Clk4 is
"* either '1' or '0', DSCK and the clock according to which DSDI is sent and
"* DSDO is sampled should be changed.
"* When TxClkSns is '0' - DSCK will be !Clk4 while transmit will be done
"*         according to Clk4 and receive by !Clk4.
"* When TxClkSns is '1' - DSCK will be Clk4 while transmit will be done
"*         according to !Clk4~ and receive by Clk4.
*****
equations
```

```
TxClkSns.clk = Clk2;
TxClkSns.ar = Reset;
```

```
state_diagram TxClkSns
```

```
state TX_ON_RISING:
    if (HOST_WRITE_ADI_DATA & BndTmrExp.fb & Clk4) then
        TX_ON_FALLING
    else
        TX_ON_RISING;
state TX_ON_FALLING:
    if (HOST_WRITE_ADI_DATA & BndTmrExp.fb & !Clk4) then
        TX_ON_RISING
    else
        TX_ON_FALLING;
```

### Support Information

```
*****
"* Tx shift Register.
"* 8 bits shift register which either shifts data out (MSB first) or holds
"* its data. The edge (in Clk4 terms) upon which the above actions are taken,
"* is determined by TxClkSns. The Tx shift register operates according to Clk2.
"* The Tx shift register is 1'st written by the host (data cycle) and along
"* with write being acknowledged to the host data is shifted out via DSDI.
"*
"* In order of saving logic, the Tx shift register is shared with the Receive
"* shift register, this, due to the fact that when a bit is shifted out a FF
"* becomes available. Since the Tx shift register is shifted MSB first, its
"* LSB FFs are gradually becoming available for received data.
"* To provide a 1/2 DSCK hold time for DSDI, a single FF receive SR is used
"* which is the source for the Tx shift register. (if 0 hold is required
"* for DSDI this FF may be omitted)
*****
```

equations

```
TxReg.clk = Clk2;
TxReg.ar = Reset;
```

```
when ( HOST_WRITE_ADI_DATA & BndTmrExp.fb & !STATE_TX_ENABLED) then
  [TxReg7..TxReg1] := [PD7..PD1].pin; " latching ADI data
else when (STATE_TX_ENABLED & STATE_TX_ON_RISING & !Clk4 #
  STATE_TX_ENABLED & STATE_TX_ON_FALLING & Clk4) then
  [TxReg7..TxReg1] := [TxReg6..TxReg0].fb; " shifting out MSB 1'st.
else
  [TxReg7..TxReg1] := [TxReg7..TxReg1].fb; " Holding value.
```

```
when ( HOST_WRITE_ADI_DATA & BndTmrExp.fb & !STATE_TX_ENABLED) then
  TxReg0 := PD0.pin;
else when (STATE_TX_ENABLED & STATE_TX_ON_RISING & !Clk4 #
  STATE_TX_ENABLED & STATE_TX_ON_FALLING & Clk4) then
  TxReg0 := RxReg0.fb;
else
  TxReg0 := TxReg0.fb;
```

### Support Information

```
*****
"* Receive Shift Register.
"* A single stage shift register used as a source for the Tx shift register.
"* In normal mode the input for the Rx shift register is the pda's DSDO, while
"* in diagnostic loopback mode, data is taken directly from the Tx shift
"* serial output.
"*
"* The output of the Rx shift register is fed to the input of the Tx shift
"* register. When transmission (and reception) is done the received data
"* word is composed of the Rx shift register (LSB) concatenated with the
"* 7 LSBs of the Tx shift register.
"*
"* The edge (in Clk4 terms) upon which data is shifted in is determined by
"* TxClkSns as with the Tx shift register but on opposite edges, i.e.,
"* data is shifted Out from the Tx shift register on the Falling edge of
"* DSCK while is shifted In to the Rx shift register on the Rising edge
"* DSCK. (DSCK terms are constant in that regard).
*****
equations
```

```
RxReg0.clk = Clk2;
RxReg0.ar = Reset;
```

```
when ( STATE_TX_ENABLED & STATE_TX_ON_RISING & Clk4 #
    STATE_TX_ENABLED & STATE_TX_ON_FALLING & !Clk4) & (!IN_DIAG_LOOP_BACK) then
    RxReg0.d = DSDO; "shift in ext data
else when ( STATE_TX_ENABLED & STATE_TX_ON_RISING & Clk4 #
    STATE_TX_ENABLED & STATE_TX_ON_FALLING & !Clk4) & IN_DIAG_LOOP_BACK then
    RxReg0.d = TxReg7.fb;" shift in from transmit reg
else
    RxReg0.d = RxReg0.fb;" hold value
```

```
*****
"* AdsReq.
"* Host from ads, read acknowledge. This state machine generates an automatic
"* ADS read request from the host when either a byte of data is received in the
"* Rx shift register or the status request bit in the control register is
"* active during a previous host write to the control register.
"* When the host detects AdsReq asserted, it asserts HstAck in return. HstAck
```

**Support Information**

```

"* double synchronized from the ADI port and delayed using the bundle delay
"* compensation timer to negate AdsReq. When the host detects AdsReq negated
"* it knows that data is valid to be read. After the host reads the data it
"* negates HstAck.
"* The machine steps through these states :
"* 0 - !ADS_REQ_ACTIVE
"* 1 - ADS_REQ_ACTIVE
*****
equations
    AdsReq.clk = Clk2;
    AdsReq.ar  = Reset;
    AdsReq.oe  = ADS_IS_SELECTED;

    S_HstAck.clk = Clk2;
    DS_HstAck.clk = Clk2;

    S_HstAck := HstAck;
    DS_HstAck := HstAck & S_HstAck;"double synced

state_diagram AdsReq
state !ADS_REQ_ACTIVE:
    if ( TxEn.fb & TxWordEnd  #" end of data shift to PDA
        ADS_SEND_STATUS) then" end of control write and status required
        ADS_REQ_ACTIVE
    else
        !ADS_REQ_ACTIVE;

state ADS_REQ_ACTIVE:
    if ( HOST_READ_ADI & BndTmrExp.fb ) then
        !ADS_REQ_ACTIVE
    else
        ADS_REQ_ACTIVE;

*****

"* ADI control register.
"* The ADI control register is written upon host to ADI write with a
"* D_C~ line is in control mode. It also may be read when StatusRequest~ bit
"* is active.
"*
"* Control register bits description:

```

### Support Information

```
"*
"* DebugEntry~: (Bit 0). When this bit is active (L), the pda will enter debug
"* mode immediately after reset, i.e., DSCK will be held high
"* after the rising edge of SRESET*. When negated, DSCK will be
"* held low after the rising edge of SRESET so the pda will start
"* running instantly.
"* DiagLoopBack~: (Bit 1). When active (L), the interface is in Diagnostic
"* Loopback mode. I.e., the source for the Rx shift register is
"* the output of the Tx shift register. During that mode, DSCK
"* and DSDI are tri-stated, so no arbitrary data is sent to the
"* debug port. When inactive, the interface is in normal mode,
"* i.e., DSCK and DSDI are driven and the source of the Rx shift
"* register is DSDO.
"* StatusRequest~: (Bit 2). When active (L) any write to the control register
"* will be followed by a status read cycle initiated by the
"* debug port controller, i.e., AdsReq will be asserted after
"* the write cycle ends. When inactive, a write to the control
"* register will not be followed by a read from status register.
"* Delay1~, Delay0~: (Bits 4,3). The contents of this field is the 1's
"* complement of the number of wait states (in 1/2 system clock
"* terms - Clk2) inserted during a host write / read cycles.
"* After the interface has been reset, these bits wake up at 0,
"* meaning, 3 wait states are inserted.
"*
"* Important!!! All bits wake up active (L) after reset.
"*
```

\*\*\*\*\*

equations

```
AdiCtrlReg.clk = Clk2;
AdiCtrlReg.ar = Reset;"All active low.
```

```
when ( HOST_WRITE_ADI_CONTROL & BndTmrExp.fb) then
    AdiCtrlReg.d = [PD4.pin, PD3.pin, PD2.pin, PD1.pin, PD0.pin];
else
    AdiCtrlReg.d = AdiCtrlReg.fb;
```



**Support Information**

```
*****
"* ADI Data Bus.
"* The Adi data bus is driven towards the host when the host reads the i/f.
"* When D_C~ line is high (data) the Rx shift register contents is driven. If
"* D_C~ is low (control) the status register contents is driven.
"* The status register contains all control register's bits (4:0) with the
"* addition of the following:
"*
"* InDebugMode: (Bit 5). When this bit is active (H), the pda is in debug mode,
"* i.e., VFLS(0:1) lines are driven high.
"* TxError: (Bit 6). When this bit is active (H), it signals that the pda was
"* reset (internally) during data transmission. (i.e., data received
"* during that transmission is corrupted). This bit is reset (L) when
"* either happens: (1) - The interface is reset by the host (both
"*AdsHardReset and AdsSoftReset are asserted (H) by the host
"* while the board is selected). (2) - The host writes the interface with
"* D_C~ signal low (control) and with data bit 6 high. (3) - a new data
"* word is written to the Tx shift register. (I.e., error is not kept
"*indefinitely).
"* PdaRst: (Bit 7). When this bit is active (H), it means that either SRESET*
"*or HRESET* or both are driven by the pda. The host have to wait until
"* this bit negates so that data may be written to the debug port.
*****
```

equations

```

    PDOe = DATA_BUFFERS_ENABLE ;

    PD.oe = PDOe;

    when ( READ_DATA_WORD_ON_ADI_BUS) then
        PD = RxReg.fb;
    elseif ( STATUS_WORD_ON_ADI_BUS ) then
        PD = [PdaRst.fb, TxError.fb, InDebugMode.fb, Delay1~.fb, Delay0~.fb,
            StatusRequest~.fb, DiagLoopBack~.fb, DebugEntry~.fb ];

    InDebugMode.clk = Clk2;

    InDebugMode := VFLS1 & VFLS0; "synchronized.

    Run.oe = H;
    !Run = IS_IN_DEBUG_MODE;"when 1 lits a led.
```

## Support Information

```
*****
"* DSK.
"* PDA debug port, gated serial clock.
*****

equations
    DSK.oe = ADS_IS_SELECTED;

    when ( ADS_IS_SELECTED & !PdaSoftReset~ ) then
        DSK = H;           "debug mode enable
    else when ( ADS_IS_SELECTED & !TxEn.fb & PdaSoftReset~ ) then
        DSK = !DebugEntry~.fb;"debug mode direct entry
    else when (ADS_IS_SELECTED & TxEn.fb & STATE_TX_ON_RISING) then
        DSK = !Clk4;"debug port clock
    else when (ADS_IS_SELECTED & TxEn.fb & STATE_TX_ON_FALLING) then
        DSK = Clk4;"debug port inverted clock
    else when (!ADS_IS_SELECTED) then
        DSK = H;           "default value, infact X

*****
"* DSDI.
"* Debug Port Serial Data in. (from Pda).
"* To provide better hold time for DSDI from the last rising edge of DSK,
"* a dedicated enable for DSDI is provided - DSDI_ENABLE.
*****

equations
    DsdiEn.ar = Reset;
    DsdiEn.clk = Clk2;

state_diagram DsdiEn
    state DSDI_DISABLED:
        if(HOST_WRITE_ADI_DATA & BndTmrExp.fb & !PdaRst.fb) then
            DSDI_ENABLED
        else
            DSDI_DISABLED;
    state DSDI_ENABLED:
        if(STATE_TX_DISABLED # PdaRst.fb) then
            DSDI_DISABLED
        else
            DSDI_ENABLED;
```

## Support Information

equations

```
DSDI.oe = ADS_IS_SELECTED & !IN_DIAG_LOOP_BACK; "avoid junk driven on DSDI input  
"during diagnostic loop back mode.
```

```
when (ADS_IS_SELECTED & !PdaSoftReset~) then
```

```
    DSDI = H;
```

```
else when (ADS_IS_SELECTED & !STATE_DSDI_ENABLED & PdaSoftReset~ ) then
```

```
    DSDI = L;
```

```
else when (ADS_IS_SELECTED & STATE_DSDI_ENABLED) then
```

```
    DSDI = TxReg7.fb;
```

```
else
```

```
    DSDI = L;
```

```
*****
```

```
/* TxError.
```

```
/* This bit of the status register is set ('1') when the pda internally resets
```

```
/* during data transmission over the debug port.
```

```
/* When this bit is written '1' by the adi port (control) the status bit is
```

```
/* cleared. Writing '0' has no influence on that bit.
```

```
*****
```

equations

```
TxError.clk = Clk2;
```

```
TxError.ar = Reset;
```

state\_diagram TxError

```
state TX_DONE_OK:
```

```
    if(STATE_TX_ENABLED & PdaRst.fb) then
```

```
        TX_INTERRUPTED
```

```
    else
```

```
        TX_DONE_OK;
```

```
state TX_INTERRUPTED:
```

```
    if (HOST_WRITE_ADI_CONTROL & BndTmrExp.fb & PD6.pin
```

```
        # HOST_WRITE_ADI_DATA & BndTmrExp.fb & !PdaRst.fb) then
```

```
        TX_DONE_OK
```

```
    else
```

```
        TX_INTERRUPTED;
```

```
end dbg_prt6
```

Support Information

**A•2 U10 - Auxiliary Board Control**

```
*****
"* In this file (5):
"* 1) The use of BCLOSE~ is removed. This due to the assignment
"*   BCLOSE~ to GPL4A. In order of using of GPL4A bit in the upm to determine
"*   data sampling edge, GPL4A may not be used as a GPL. Therefore DramBankXCs~
"*   must envelope the cycle so that data buffers remain open throughout the
"*   cycle.
"* 2) Removed CS support for flash configuration. I.e., FlashCs1~ will not be
"*   asserted during hard reset. Flash configuration will be supported on
"*   silicon next revisions.
"*   data buffers will still open for flash configuration when hard reset
"*   asserted and flash configuration option bit, asserted.
"* 3) Since Bclose~ is no longer available, the data buffers will open
"*   asynchronously. I.e., driven directly by the various chip-selects.
"*   to provide data hold (0) on write cycles to flash, CSNT bit in the OR
"*   should be programmed active, while ACS == 00.
*****
"* In This file (6), A12 and A11 are removed from the flash selection equation
"* since they can select only a 1/2 Mbyte of flash rather than 2Mbyte selection
"* needed. Therefore, only one bank of 2 Mbyte flash may be used (MCM29F020).
"* The rest of the CS are driven high constantly.
*****
"* In this file (7):
"* - Pon Reset Out is removed. Pon Reset is driven directly to MPC.
"* - Modck0 becomes Modck2
"* - A9 and A10 replace A11 and A12 in flash bank selection
"* - Optional BufClose~ is removed.
"* - DramEn becomes active-low to support debug-station support changes.
"* - Added F_PD(1:3) to support SMART Flash SIMMs.
"* - Support for 32KHz crystal - renewed.
*****
"* In this file (8):
"* - Added protection against data contention for write cycles after
"*   Flash read cycle. This is achieved using a state-machine which identifies
"*   end of flash read and a chain of internal gates serving as a delay line.
"*   This kind of solution guaranties a fixed delay over the data buffer enable
"*   signal, that is, only after a flash read cycle.
*****
"* In this file (9):
```

### Support Information

```
"* - The addressing scheme of the flash is changed so that the bank does
"*   not occupy a space bigger than its real size. I.e. A9 and A10 use
"*   is conditioned with the module type.
*****
module brd_ctl9
title 'MPC821ADS Board Misc. Control Functions.'

*****
"* Device declaration.
*****

U10 device 'mach220a';

*****
"* #####
"* # # # ##### ##### # # ## # #####
"* # # # # # # # # # # # # # # #
"* ##### ## # ##### # # # # # # # # # #####
"* # ## # # ##### # # # ##### # # #
"* # # # # # # # # # # # # # # # # # # # #
"* ##### # # # ##### # # # # # # # # # # # # # # #
*****

*****
"* Pins declaration.
*****

*****
"* clock generator
*****

SYSCLK PIN 15;" pda clkout

*****
"* Dram Associated Pins.
*****

A9 PIN 55;
A10 PIN 39;
A19 PIN 38;
A20 PIN 2;
```

### Support Information

```
A30    PIN 36;" pda address lines inputs (IN)

R_W~   PIN 23;

SizeDetect1  PIN 26;
SizeDetect0  PIN 20;    " dram simm size detect lines (IN)

HalfWord~   PIN 51;    " dram port width selection from control register;
              " '1' - 32 bit
              " '0' - 16 bit

DramBank1Cs~PIN 45;    " 1'st bank chip-select(IN, L)
DramBank2Cs~PIN 46;    " 2'nd bank chip-select (IN, L)

DramEn~     PIN 54;    " Dram enable from control reg. (IN, H). Active
              " high to support power control.

DramAdd10   PIN 32 istype 'com';
DramAdd9    PIN 33 istype 'com';" dram address lines

Ras1~       PIN 28 istype 'com';
Ras1DD~     PIN 30 istype 'com';
Ras2~       PIN 29 istype 'com';
Ras2DD~     PIN 31 istype 'com';" dram RAS lines.

*****
"* Flash Associated Pins.
*****

F_PD1      PIN 7;
F_PD2      PIN 65;
F_PD3      PIN 41;

FlashCs~   PIN 49;" flash bank chip-select
FlashEn~   PIN 50;" flash enable from control reg.

FlashCs1~  PIN 12 istype 'com';" Flash bank1 chip-select
FlashCs2~  PIN 22 istype 'com';" Flash bank2 chip-select
FlashCs3~  PIN 57 istype 'com';" Flash bank3 chip-select
FlashCs4~  PIN 24 istype 'com';" Flash bank4 chip-select
```

## Support Information

```
FlashOe~    PIN 58 istype 'com';" Flash output enable.

*****
"* Control Register pins
*****
ContRegCs~  PIN 59;" control register cs from pda
ContRegEn~  PIN 56;" control register enable from control register.

*****
"* Reset & Interrupt Logic Pins.
*****

Rst0        PIN 13; " connected to N.C. of Reset P.B.
Rst1        PIN 21; " connected to N.O. of Reset P.B.

!KAPORIn~   PIN 25; " Keep Alive Power On Reset In. (H)
!RegPORIn~  PIN 9;  " Regular Power On Reset In. (H)

HardReset~  PIN 48 istype 'com';    " Actual hard reset output (O.D.)
SoftReset~  PIN 40 istype 'com';    " Actual soft reset output (O.D.)
ResetConfig~PIN 67 istype 'com';    " Drives the RSTCONF* signal of the pda.
DriveConfig~PIN 63 istype 'com';    " Drives configuration data to the pda

Abr0        PIN 10;          " connected to N.C. of Abort P.B.
Abr1        PIN 11;          " connected to N.O. of Abort P.B.

NMIEn       NODE istype 'com';    " enables T.S. NMI pin
NMI~        PIN 44 istype 'com';    " Actual NMI pin (O.D.)

*****
"* Power On Reset Configuration Support
*****
ModIn       PIN 64;          " MODCK dip-switch
Modck2      PIN 60 istype 'com';    " MODCK2 output
Modck1      PIN 66 istype 'com';    " MODCK1 output

ModckOe     NODE istype 'com';    " enables MODCKs towards PDA during
          " Hard Reset.
```

**Support Information**

```

*****
"* Data Buffers Enables and Reset configuration support
*****

TA~          PIN 6;          " transfer Acknowledge
TEA~         PIN 47;         " Transfer Error Acknowledge.

FlashCfgEn~  PIN 17;        " flash configuration enable from control
                " register.

PccEn~       PIN 4;         " PCMCIA channel enable from control reg.

PccCE1~     PIN 16;
PccCE2~     PIN 43;

UpperHalfEn~PIN 3 istype 'com,invert';    " bits 0:15 data buffer enable
LowerHalfEn~PIN 5 istype 'com,invert';    " bits 16:31 data buffer enable

PccEvenEn~  PIN 14 istype 'com,invert';   " pcc upper byte data buffer enable
PccOddEn~   PIN 37 istype 'com,invert';   " pcc lower byte data buffer enable

PccR_W~     PIN 62 istype 'com';" pcmcia data buffers direction

*****
"*   ###                               *
"*   #   #   #   #####   #####   #####   #   #   ##   #   #####   *
"*   #   ##  #   #   #   #   #   #   #   #   #   #   #   #   #   #   *
"*   #   #  #  #   #   #####   #   #   #   #   #   #   #   #   #   #   *
"*   #   #  #  #   #   #   #####   #   #   #   #####   #   #   #   *
"*   #   #  ##  #   #   #   #   #   #   #   ##  #   #   #   #   #   #   *
"*   ###  #   #   #   #####   #   #   #   #   #   #   #   #####   #####   *
*****

```

Freescale Semiconductor, Inc.



### Support Information

```
*****
"* Reset & Interrupt Logic Pins.
*****

RstDebl      NODE istype 'com';    " reset push button debouncer
AbrDebl      NODE istype 'com';    " abort push button debouncer

HardResetEn  NODE istype 'com';    " enables T.S. hard reset pin
SoftResetEn  NODE istype 'com';    " enables T.S. soft reset pin

ConfigHold2,
ConfigHold1,
ConfigHold0  NODE istype 'reg,buffer';" supplies data hold time for
              " hard reset configuration

ConfigHoldEnd  NODE istype 'com';

*****
"* data buffers enable.
*****

SyncHardReset~  NODE istype 'reg,buffer';    " synchronized hard reset
DSyncHardReset~ NODE istype 'reg,buffer';    " double synchronized hard reset

SyncTEA~        NODE istype 'reg,buffer';    " needed since TEA~ is O.D.

HoldOffConsideredNODE istype 'reg,buffer';    " data drive hold-off state
              " machine.

D_FlashOe~     NODE istype 'com';            " delayed flash output enable
DD_FlashOe~    NODE istype 'com';            " double delayed flash output
              " enable

TD_FlashOe~    NODE istype 'com';" triple delayed flash output
              " enable

QD_FlashOe~    NODE istype 'com';" quad delayed
PD_FlashOe~    NODE istype 'com';" penta delayed

KeepPinsConnected NODE istype 'com';
```

**Support Information**

```

*****
"* #####                                         *
"* #      # ##### # # ##### ##### ## # # ##### *
"* #      # # ## # #      # # # ## # #      *
"* #      # # # # # ##### # # # # # # # # # *
"* #      # # # # # # # # # ##### # # # # # *
"* #      # # # # # ## # # # # # # # # # # *
"* ##### ##### # # ##### # # # # # # # # *
"*
"* #####                                         *
"* #      # ##### ##### #      ## ##### *
"* #      # # # # # # # # # # # # # # *
"* #      # ##### # # # # # # # # # # ##### *
"* #      # # # # # # # ##### ##### *
"* #      # # # # # # # # # # # # # *
"* ##### ##### ##### ##### # # # # # *
"*
"* ## ##### # ##### # # *
"* # # # # # # # # # # *
"* # # # # # # # # # # *
"* ##### # # # # # # # # *
"* # # # # # # # # # *
"* # # # # # ##### # # *
*****
H, L, X, Z = 1, 0, .X., .Z.;
C, D, U   = .C., .D., .U.;

*****
"* SLOW_32K_LOCK = 1;
*****

"* Signal groups
*****
PdaAdd = [A9,A10,A19,A20,A30];
DramAdd = [DramAdd10,DramAdd9];
DramCS~ = [DramBank2Cs~,DramBank1Cs~];
RAS = [Ras1~,Ras1DD~,Ras2~,Ras2DD~];
SD = [SizeDetect1,SizeDetect0];
FlashCsOut = [FlashCs4~,FlashCs3~,FlashCs2~,FlashCs1~];
Reset = [HardReset~,SoftReset~];
ResetEn = [HardResetEn,SoftResetEn];

```

### Support Information

```
Rst = [Rst1,Rst0];
Abr = [Abr1,Abr0];
Debounce = [RstDeb1,AbrDeb1];
DramCs = [DramBank2Cs~,DramBank1Cs~];
Cs = [ContRegCs~,FlashCs~,DramBank1Cs~,DramBank2Cs~];
PccCs = [PccCE1~,PccCE2~];
LocDataBufEn = [UpperHalfEn~,LowerHalfEn~];
PccDataBufEn = [PccEvenEn~,PccOddEn~];
ModuleEn = [DramEn~,FlashEn~,PccEn~,ContRegEn~];
SyncReset = [SyncHardReset~,DSyncHardReset~];
RstCause = [Rst1,Rst0,Abr1,Abr0,KAPORIn~,RegPORIn~];
Stp = [TA~];
Modck = [Modck2, Modck1];
ConfigHold = [ConfigHold2, ConfigHold1, ConfigHold0];
F_PD = [F_PD3, F_PD2, F_PD1];

*****
/* Dram Declarations.
*****

DRAM_ENABLE_ACTIVE = 0;

DRAM_ENABLED = (DramEn~ == DRAM_ENABLE_ACTIVE);

SIMM36100 = (SD == 0);
SIMM36200 = (SD == 3);
SIMM36400 = (SD == 2);
SIMM36800 = (SD == 1);

IS_HALF_WORD = (HalfWord~ == 0);

*****
/* Flash Declarations.
*****

FLASH_ENABLE_ACTIVE = 0;

FLASH_ENABLED = (FlashEn~ == FLASH_ENABLE_ACTIVE);

MCM29020 = (F_PD == 0);
MCM29040 = (F_PD == 7);
MCM29080 = (F_PD == 6);
SM732A1000A = (F_PD == 2);
```

### Support Information

```
SM732A2000 = (F_PD == 3);

FLASH_BANK1 = ( (MCM29020 # SM732A1000A) #
                (MCM29040 & !A10) #
                (MCM29080 & !A9 & !A10) #
                (SM732A2000 & !A9) );

FLASH_BANK2 = ( (MCM29040 & A10) #
                (MCM29080 & !A9 & A10) #
                (SM732A2000 & A9) );

FLASH_BANK3 = (A9 & !A10 & MCM29080);
FLASH_BANK4 = (A9 & A10 & MCM29080);

*****
"* Reset Declarations.
*****

KEEP_ALIVE_PON_RESET_ACTIVE = 0;
REGULAR_PON_RESET_ACTIVE = 0;
HARD_RESET_ACTIVE = 0;
SOFT_RESET_ACTIVE = 0;

HARD_CONFIG_HOLD_VALUE = 4;

KEEP_ALIVE_POWER_ON_RESET = (KAPORIn~ == KEEP_ALIVE_PON_RESET_ACTIVE);

DRIVE_MODCK_TO_PDA = (HardReset~ == HARD_RESET_ACTIVE);" have modck stable
                    " during hard reset.

REGULAR_POWER_ON_RESET = (RegPORIn~ == REGULAR_PON_RESET_ACTIVE);

HARD_RESET_ASSERTED = (SyncHardReset~.fb == HARD_RESET_ACTIVE);

HARD_RESET_NEGATES = ( (SyncHardReset~.fb != HARD_RESET_ACTIVE )
                      & (DSyncHardReset~.fb == HARD_RESET_ACTIVE));
                    " detecting hard reset negation

*****
"* data buffers enable.
*****

BUFFER_DISABLED = 1;
BUFFER_ENABLED = !BUFFER_DISABLED;
```

**Support Information**

```
CONTROL_REG_ENABLE_ACTIVE = 0;
FLASH_CONFIG_ENABLED_ACTIVE = 0;
PCMCIA_ENABLE_ACTIVE = 0;

GPL_ACTIVE = 0;

TEA_ASSERTS = (!TEA~ & SyncTEA~.fb); " first clock of TEA~ asserted

CONTROL_REG_ENABLED = (ContrRegEn~ == CONTROL_REG_ENABLE_ACTIVE);

FLASH_CONFIGURATION_ENABLED = (FlashCfgEn~ == FLASH_CONFIG_ENABLED_ACTIVE);

PCC_ENABLED = (PccEn~ == PCMCIA_ENABLE_ACTIVE);

NO_HOLD_OFF = 0;
HOLD_OFF_CONSIDERED = 1;

STATE_HOLD_OFF_CONSIDERED = (HoldOffConsidered.fb == HOLD_OFF_CONSIDERED);
STATE_NO_HOLD_OFF = (HoldOffConsidered.fb == NO_HOLD_OFF);

END_OF_FLASH_READ = !TA~ & !FlashCs~ & R_W~; " end of flash read cycle.
END_OF_OTHER_CYCLE = (!TA~ & FlashCs~ #           " another access or
                    !TA~ & !FlashCs~ & !R_W~); " flash write

HOLD_OFF_PERIOD = (!R_W~ & !PD_FlashOe~.fb);
*****
"* Equations, state diagrams.                                     *
*****
"*                                                                    *
"* #####                                                         *
"* #           ##### # # ## ##### # ##### # # # # # # # # # # *
"* #           # # # # # # # # # # # # # # # # # # # # # # # # *
"* ##### # # # # # # # # # # # # # # # # # # # # # # # # # # # *
"* #           # # # # # # ##### # # # # # # # # # # # # # # # # *
"* #           # # # # # # # # # # # # # # # # # # # # # # # # # *
"* ##### # # # # # # # # # # # # # # # # # # # # # # # # # # # *
"*                                                                    *
*****
```

Freescale Semiconductor, Inc.

ARCHIVED BY FREESCALE SEMICONDUCTOR, INC.

## Support Information

```
*****
"* Reset Logic
*****
equations

Reset.oe = ResetEn;

Reset = 0;" open drain

RstDebl = !( Rst1 & (!( RstDebl.fb & Rst0) ) );    " Reset push-button debouncer

AbrDebl = !( Abr1 & (!( AbrDebl.fb & Abr0) ) );    " Abort push-button debouncer

HardResetEn = RstDebl.fb & AbrDebl.fb " both buttons are depressed;
               # REGULAR_POWER_ON_RESET;

SoftResetEn = RstDebl.fb & !AbrDebl.fb;" only reset button depressed

*****
"* Power On reset configuration
*****
equations

Modck.oe = ModckOe;

ModckOe = DRIVE_MODCK_TO_PDA;

Modck2 = L;
#ifdef SLOW_32K_LOCK {

    Modck2 = ModIn;" support for 1:513 (32KHz crystal) or
    Modck1 = ModIn;" 1:5 (5MHz clock gen.) via CLK4IN
}

#ifdef SLOW_32K_LOCK {

    Modck2 = !ModIn;" support for 1:1 or 1:5 from CLK4IN only
    Modck1 = H;" no support for 32K oscillator.
}
}
```

## Support Information

```
*****
"* Hard reset configuration
*****
equations

ResetConfig~.oe = H;
DriveConfig~.oe = H;

"* Configuration hold counter. Since the rise time of the HARD RESET signal
"* is relatively slow, there is a need to provide a hold time for reset
"* configuration.

ConfigHold.clk = SYSCLK;

when (SyncHardReset~.fb & !ConfigHoldEnd.fb) then ConfigHold := ConfigHold.fb +1;
else when (SyncHardReset~.fb & ConfigHoldEnd.fb) then ConfigHold := ConfigHold.fb;
else when (!SyncHardReset~.fb) then ConfigHold := 0;

ConfigHoldEnd = (ConfigHold.fb == HARD_CONFIG_HOLD_VALUE); " terminal count

!ResetConfig~ = !HardReset~;" drives RSTCONF~ to pda

!DriveConfig~ = !ConfigHoldEnd.fb; " drives configuration data on the bus.

*****
"* NMI generation
*****
equations

NMI~.oe = NMIEen;

NMI~ = 0;" O.D.

NMIEen = !RstDebl.fb & AbrDebl.fb;" only abort button depressed

*****
"* local data buffers enable
*****
equations
```

## Support Information

```
SyncHardReset~.clk = SYSCLK;
DSyncHardReset~.clk = SYSCLK;

SyncHardReset~ := HardReset~;
DSyncHardReset~ := SyncHardReset~.fb;

SyncTEA~.clk = SYSCLK;
SyncTEA~ := TEA~;

LocDataBufEn.oe = 3;

!UpperHalfEn~ = (!DramBank1Cs~ & DRAM_ENABLED #
                !DramBank2Cs~ & (SIMM36200 # SIMM36800) & DRAM_ENABLED #
                !FlashCs~ & FLASH_ENABLED #
                !ContRegCs~ & CONTROL_REG_ENABLED #
                !PccCE1~ & PCC_ENABLED #
                !PccCE2~ & PCC_ENABLED #
                !ConfigHoldEnd.fb) &
                (STATE_HOLD_OFF_CONSIDERED & (!HOLD_OFF_PERIOD) #
                STATE_NO_HOLD_OFF);

!LowerHalfEn~ = (!DramBank1Cs~ & DRAM_ENABLED & !IS_HALF_WORD #
                !DramBank2Cs~ & (SIMM36200 # SIMM36800) & !IS_HALF_WORD & DRAM_ENABLED #
                !FlashCs~ & FLASH_ENABLED #
                !ConfigHoldEnd.fb & FLASH_CONFIGURATION_ENABLED) &
                (STATE_HOLD_OFF_CONSIDERED & !HOLD_OFF_PERIOD #
                STATE_NO_HOLD_OFF);

*****
"* local data buffers disable (data contention protection)
*****

equations

HoldOffConsidered.clk = SYSCLK;

D_FlashOe~ = FlashOe~;
DD_FlashOe~ = D_FlashOe~.fb;
TD_FlashOe~ = DD_FlashOe~.fb;
QD_FlashOe~ = TD_FlashOe~.fb;
PD_FlashOe~ = QD_FlashOe~.fb;
```



### Support Information

```
@ifdef DEBUG {
equations

HoldOffConsidered := HOLD_OFF_CONSIDERED;

}

@ifndef DEBUG {

state_diagram HoldOffConsidered
state NO_HOLD_OFF:
    if (END_OF_FLASH_READ & DSyncHardReset~.fb) then
        HOLD_OFF_CONSIDERED
    else
        NO_HOLD_OFF;
state HOLD_OFF_CONSIDERED:
    if (END_OF_OTHER_CYCLE # !DSyncHardReset~.fb) then
        NO_HOLD_OFF
    else
        HOLD_OFF_CONSIDERED;

}

*****
"* pcc data buffers enable
*****

equations

PccDataBufEn.oe = 3;

!PccEvenEn~ = !PccCE1~ & PCC_ENABLED & !HARD_RESET_ASSERTED &
    (STATE_HOLD_OFF_CONSIDERED & HOLD_OFF_PERIOD #
    STATE_NO_HOLD_OFF);

!PccOddEn~ = !PccCE2~ & PCC_ENABLED & !HARD_RESET_ASSERTED &
    (STATE_HOLD_OFF_CONSIDERED & HOLD_OFF_PERIOD #
    STATE_NO_HOLD_OFF);

*****
"* pcc data buffers direction
*****

equations
```

## Support Information

```
PccR_W~.oe = H;
```

```
PccR_W~ = R_W~;
```

```
*****  
* Dram Address lines.  
* These lines are connected to the dram high order address lines A9 and A10  
* (if available). These lines change value according to the dram size and  
* port size.  
* The dram size is encoded from the presence detect lines (see definitions  
* above) and the port size is determined by the control register.  
*****  
equations
```

```
DramAdd.oe = 3;
```

```
when (!IS_HALF_WORD # IS_HALF_WORD & (SIMM36400 # SIMM36800)) then
```

```
    DramAdd9 = A20;
```

```
else
```

```
    DramAdd9 = A30;
```

```
when ( (SIMM36400 # SIMM36800) & !IS_HALF_WORD) then
```

```
    DramAdd10 = A19;
```

```
else when ( (SIMM36400 # SIMM36800) & IS_HALF_WORD) then
```

```
    DramAdd10 = A30;
```

```
else
```

```
    DramAdd10 = 0;
```

```
*****  
* RAS generation.  
* Since the dram simm requires RAS signals to be split due to high capacitive  
* load and to allow 16 bit operation. When working with 16 bit port size,  
* the double drive RAS signals are disabled.  
*****  
equations
```

```
RAS.oe = ^hf;
```

```
!Ras1~ = !DramBank1Cs~ & DramBank2Cs~ & DRAM_ENABLED;
```

**Support Information**

```
!Ras2~ = !DramBank2Cs~ & DramBank1Cs~ & DRAM_ENABLED & (SIMM36200 # SIMM36800);

!Ras1DD~ = !DramBank1Cs~ & DramBank2Cs~ & DRAM_ENABLED;
!Ras2DD~ = !DramBank2Cs~ & DramBank1Cs~ & DRAM_ENABLED & (SIMM36200 # SIMM36800);

*****
"* Flash Chip Select
*****
equations

FlashCsOut.oe = ^hf;

!FlashCs1~ = FLASH_ENABLED & !FlashCs~ & FLASH_BANK1;
!FlashCs2~ = FLASH_ENABLED & !FlashCs~ & FLASH_BANK2 ;
!FlashCs3~ = FLASH_ENABLED & !FlashCs~ & FLASH_BANK3 ;
!FlashCs4~ = FLASH_ENABLED & !FlashCs~ & FLASH_BANK4 ;

FlashOe~.oe = H;

!FlashOe~ = FLASH_ENABLED & R_W~;

*****
"* Auxiliary functions
*****
equations

KeepPinsConnected = TA~ & KAPORIn~;

end brd_ct19
```



**Support Information**

```

BrdContRegCs~    PIN 50;
TA~              PIN 17;
R_W~             PIN 20;

A28              PIN 51;
A29              PIN 54;

D0               PIN 28;
D1               PIN 29;
D2               PIN 30;
D3               PIN 31;
D4               PIN 36;
D5               PIN 32;
D6               PIN 2;
D7               PIN 26;
D8               PIN 24;
D9               PIN 9;
D10              PIN 6;
D11              PIN 14;
D12              PIN 33;
D13              PIN 37;
D14              PIN 41;
D15              PIN 7;
    
```

```

*****
"* Board Control Pins. Read/Write.
*****

FlashEn~        PIN 44 istype 'reg,buffer'; " flash enable.
DramEn~         PIN 55 istype 'reg,buffer'; " dram enable
EthEn~          PIN 46 istype 'reg,buffer'; " ethernet port enable
InfRedEn~       PIN 59 istype 'reg,buffer'; " infra-red port enable
FlashCfgEn~     PIN 25 istype 'reg,buffer'; " flash configuration enable
CntRegEn~       PIN 13 istype 'reg,buffer'; " control register access enable
RS232En~        PIN 48 istype 'reg,buffer'; " RS232 port enable
PccEn~          PIN 40 istype 'reg,buffer'; " PCMCIA port enable
PccVccOn~       PIN 39 istype 'reg,buffer'; " PCMCIA operation voltage select
PccVpp0         PIN 5 istype 'reg,buffer'; " PCMCIA programming voltage select
PccVpp1         PIN 3 istype 'reg,buffer'; " PCMCIA programming voltage select
HalfWord~       PIN 38 istype 'reg,buffer'; " 32/16 bit dram operation select
    
```

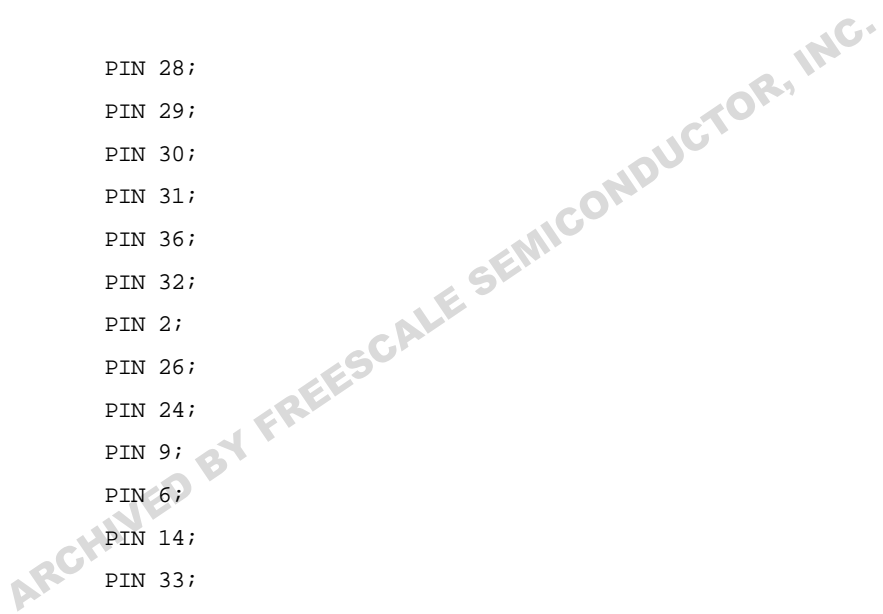

**Support Information**

```
*****
"* Board Status Pins. Read only.
*****

FlashPD7          PIN 66;
FlashPD6          PIN 65;
FlashPD5          PIN 67;

FlashPD4          PIN 43;
FlashPD3          PIN 23;
FlashPD2          PIN 22;
FlashPD1          PIN 21;" Flash presence detect lines

DramPdEdo~       PIN 12;

DramPD4           PIN 10;
DramPD3           PIN 60;
DramPD2           PIN 56;
DramPD1           PIN 45;" Dram SIMM Identification pins

ExtToolI0         PIN 57;
ExtToolI1         PIN 58;
ExtToolI2         PIN 47;
ExtToolI3         PIN 11;" External Tools Identification pins

PccVppG~         PIN 4;" PCMCIA VPP GOOD indication

*****
"* Auxiliary Pins.
*****
```

ARCHIVED BY FREESCALE SEMICONDUCTOR, INC.



Support Information

```
*****
"* #####
"* # # ##### # # ##### ##### ## # # #####
"* # # # # # # # # # # # # # # # # # # # #
"* # # # # # # # # # # # # # # # # # # # #
"* # # # # # # # # # # # # # # # # # # # #
"* # # # # # # # # # # # # # # # # # # # #
"* ##### ##### # # ##### # # # # # # # # #
"*
"* #####
"* # # ##### # # # # # # # # # # # # # #
"* # # # # # # # # # # # # # # # # # # # #
"* # # ##### # # # # # # # # # # # # # #
"* # # # # # # # # # # # # # # # # # # # #
"* # # # # # # # # # # # # # # # # # # # #
"* ##### ##### # # # # # # # # # # # # # #
"*
"* ## ##### # # # # # # # # # # # # # #
"* # # # # # # # # # # # # # # # # # # # #
"* # # # # # # # # # # # # # # # # # # # #
"* ##### # # # # # # # # # # # # # # # # # # # #
"* # # # # # # # # # # # # # # # # # # # #
"* # # # # # # # # # # # # # # # # # # # #
*****
H, L, X, Z = 1, 0, .X., .Z.;
C, D, U = .C., .D., .U.;
*****
SIMULATION = 1;
"* SLOW_PLL_LOCK = 1;
"* DRAM_8_BIT_OPERATION = 1;
*****
"* Signal groups
*****
Add = [A28,A29];
Data = [D0..D15];
ConfigReg = [ERB,IP~,RSV2,BDIS,BPS0,BPS1,RSV6,ISB0,ISB1,DBGC0,DBGC1,DBPC0,
DBPC1,RSV13,RSV14,RSV15];
```

Freescale Semiconductor, Inc.



**Support Information**

```

BPS =      [BPS0,BPS1];" boot port size
ISB =      [ISB0,ISB1];" Initial Internal Space Base
DBGC =     [DBGC0,DBGC1];" Debug Pins Configuration
DBPC =     [DBPC0,DBPC1];" Debug port location

ContReg =  [FlashEn~,DramEn~,EthEn~,InfRedEn~,FlashCfgEn~,CntRegEnProtect~,
            CntRegEn~,RS232En~,PccEn~,PccVccOn~,PccVpp0,PccVpp1,HalfWord~];

ReadContReg1 = [FlashEn~,DramEn~,EthEn~,InfRedEn~,FlashCfgEn~,CntRegEnProtect~.fb,
                CntRegEn~,RS232En~,PccEn~,PccVccOn~,PccVpp0,PccVpp1,HalfWord~,
                0,0,0];

DrivenContReg = [FlashEn~,DramEn~,EthEn~,InfRedEn~,FlashCfgEn~,
                 CntRegEn~,RS232En~,PccEn~,PccVccOn~,PccVpp0,PccVpp1,HalfWord~];

PccVcc =    [PccVccOn~];
PccVpp =    [PccVpp0,PccVpp1];

WideContReg = [FlashEn~,DramEn~,EthEn~,InfRedEn~,FlashCfgEn~,CntRegEnProtect~,
               CntRegEn~,RS232En~,PccEn~,PccVccOn~,PccVpp0,PccVpp1,HalfWord~];

StatRegIn = [FlashPD4,FlashPD3,FlashPD2,FlashPD1,DramPdEdo~,DramPD4,DramPD3,
              DramPD2,DramPD1,ExtToolI0,ExtToolI1,ExtToolI2,ExtToolI3,PccVppG~];
FlashPdHigh = [FlashPD7,FlashPD6,FlashPD5];

*****
"* Power On Reset definitions
*****
FLASH_CFG_ENABLE = 0;

K_A_PON_RESET_ACTIVE = 1;

RESET_CONFIG_ACTIVE = 0;

**** changed due to long lock delay of the pda *** 17,7,95 *****

@ifndef SLOW_PLL_LOCK {

    KA_PON_RESET = (RGPORIn == K_A_PON_RESET_ACTIVE);

```

## Support Information

```
}

#ifdef SLOW_PLL_LOCK {
    PON_DEFAULT_ACTIVE = 0;

    KA_PON_RESET = (PonDefault~ == PON_DEFAULT_ACTIVE);
}

***** end of change *****

RESET_CONFIG_DRIVEN = ((ResetConf~ == RESET_CONFIG_ACTIVE) &
                        (FlashCfgEn~ != FLASH_CFG_ENABLE));

*****
* Register Access definitions
*****
CONFIG_REG_ADD = 0;
CONTROL_REG_ADD = 1;
STATUS_REG1_ADD = 2;

PDA_WRITE_CONFIG_REG = (!BrdContRegCs~ & !TA~ & !R_W~ & !A28 & !A29 & !CntRegEn~);
PDA_WRITE_CONTROL_REG1 = (!BrdContRegCs~ & !TA~ & !R_W~ & !A28 & A29 & !CntRegEn~);
PDA_WRITE_CONTROL_REG2 = (!BrdContRegCs~ & !TA~ & !R_W~ & A28 & A29 & !CntRegEn~);

PDA_READ = (!BrdContRegCs~ & R_W~ & !CntRegEn~);

PDA_READ_CONFIG_REG = (!BrdContRegCs~ & R_W~ & !A28 & !A29 & !CntRegEn~);
PDA_READ_CONTROL_REG1 = (!BrdContRegCs~ & R_W~ & !A28 & A29 & !CntRegEn~);
PDA_READ_STATUS_REG1 = (!BrdContRegCs~ & R_W~ & A28 & !A29 & !CntRegEn~);
PDA_READ_STATUS_REG2 = (!BrdContRegCs~ & R_W~ & A28 & A29 & !CntRegEn~);

*****
* Config Reg definitions
*****
INTERNAL_ARBITRATION = 0;
EXTERNAL_ARBITRATION = !INTERNAL_ARBITRATION;
```

**Support Information**

```
IP_AT_0xFFF00000 = 0;"active low
IP_AT_0x00000000 = !IP_AT_0xFFF00000;
```

```
RSV2_ACTIVE = 1;
```

```
BOOT_DISABLE = 1;
BOOT_ENABLE = !BOOT_DISABLE;
```

```
BOOT_PORT_32 = 0;
BOOT_PORT_8 = 1;
BOOT_PORT_16 = 2;
BOOT_PORT_RESERVED = 3;
```

```
RSV6_ACTIVE = 1;
```

```
INT_SPACE_BASE_0x00000000 = 0;
INT_SPACE_BASE_0x00F00000 = 1;
INT_SPACE_BASE_0xFF000000 = 2;
INT_SPACE_BASE_0xFFF00000 = 3;
```

```
DEBUG_PINS_PCMCIA_2 = 0;
DEBUG_PINS_WATCH_POINTS = 1;
DEBUG_PINS_RESREVED = 2;
DEBUG_PINS_FOR_SHOW = 3;
```

```
DEBUG_PORT_ON_JTAG = 0;
DEBUG_PORT_NON_EXISTANT = 1;
DEBUG_PORT_RESERVED = 2;
DEBUG_PORT_ON_DEBUG_PINS = 3;
```

```
RSV13_ACTIVE = 1;
RSV14_ACTIVE = 1;
RSV15_ACTIVE = 1;
```

```
*****
***** Power On Defaults Assignments *****
*****
```

```
ERB_PON_DEFAULT = INTERNAL_ARBITRATION;
```

ARCHIVED BY FREESCALE SEMICONDUCTOR, INC.

## Support Information

IP~\_PON\_DEFAULT = IP\_AT\_0x00000000;

RSV2\_PON\_DEFAULT = !RSV2\_ACTIVE;

BDIS\_PON\_DEFAULT = BOOT\_ENABLE;

BPS\_PON\_DEFAULT = BOOT\_PORT\_32;

RSV6\_PON\_DEFAULT = !RSV6\_ACTIVE;

ISB\_PON\_DEFAULT = INT\_SPACE\_BASE\_0xFF000000;

DBGC\_PON\_DEFAULT = DEBUG\_PINS\_FOR\_SHOW;

DBPC\_PON\_DEFAULT = DEBUG\_PORT\_ON\_JTAG;

RSV13\_PON\_DEFAULT = !RSV13\_ACTIVE;

RSV14\_PON\_DEFAULT = !RSV14\_ACTIVE;

RSV15\_PON\_DEFAULT = !RSV15\_ACTIVE;

```
*****  
***** Data Bits Assignments *****  
*****
```

ERB\_DATA\_BIT = [D0];

IP~\_DATA\_BIT = [D1];

RSV2\_DATA\_BIT = [D2];

BDIS\_DATA\_BIT = [D3];

BPS\_DATA\_BIT = [D4,D5];

RSV6\_DATA\_BIT = [D6];

ISB\_DATA\_BIT = [D7,D8];

DBGC\_DATA\_BIT = [D9,D10];

DBPC\_DATA\_BIT = [D11,D12];

RSV13\_DATA\_BIT = [D13];

RSV14\_DATA\_BIT = [D14];

RSV15\_DATA\_BIT = [D15];

```
*****  
* Control Register 1 definitions.
```

ARCHIVED BY FREESCALE SEMICONDUCTOR, INC.

**Support Information**

\*\*\*\*\*

HALF\_WORD = 0;

ETH\_ENABLED = 0;

DRAM\_ENABLED = 0;

ETH\_LOOP = 1;

TPSQEL = 0;

TP\_FULLL\_DUP = 0;

CONT\_REG\_ENABLE = 0;

RS232\_ENABLE = 0;

PCC\_ENABLE = 0;

PCC\_VCC\_ON = 0;

PCC\_VCC\_OFF = !PCC\_VCC\_ON;

PCC\_VPP\_0 = 0;

PCC\_VPP\_12 = 2;

PCC\_VPP\_5 = 1;

PCC\_VPP\_TS = 3;

FLASH\_ENABLED = 0;

INF\_RED\_ENABLE = 0;

/\* FLASH\_CFG\_ENABLE = 0; needed to be defined earlier

DRAM\_5V = 0;

DRAM\_3V = !DRAM\_5V;

CNT\_REG\_EN\_PROTECT = 0; " inadvertant write protect

ARCHIVED BY FREESCALE SEMICONDUCTOR, INC.

## Support Information

```
*****
***** Power On Defaults Assignments *****
*****

#ifdef DRAM_8_BIT_OPERATION {

    HALF_WORD_PON_DEFAULT = HALF_WORD;
}
#endif DRAM_8_BIT_OPERATION {

    HALF_WORD_PON_DEFAULT = !HALF_WORD;
}

ETH_ENABLE_PON_DEFAULT = !ETH_ENABLED;

DRAM_ENABLE_PON_DEFAULT = DRAM_ENABLED;

CONT_REG_ENABLE_PON_DEFAULT = CONT_REG_ENABLE;

RS232_ENABLE_PON_DEFAULT = !RS232_ENABLE;

PCC_ENABLE_PON_DEFAULT = !PCC_ENABLE;

PCC_VCC_PON_DEFAULT = PCC_VCC_OFF;

PCC_VPP_PON_DEFAULT = PCC_VPP_TS;

FLASH_ENABLE_PON_DEFAULT = FLASH_ENABLED;

INF_RED_ENABLE_PON_DEFAULT = !INF_RED_ENABLE;

FLASH_CFG_ENABLE_PON_DEFAULT = !FLASH_CFG_ENABLE;

CNT_REG_EN_PROTECT_PON_DEFAULT = CNT_REG_EN_PROTECT;

*****
***** Data Bits Assignments *****
*****

FLASH_ENABLE_DATA_BIT = [D0];
DRAM_ENABLE_DATA_BIT = [D1];
```

ARCHIVED BY FREESCALE SEMICONDUCTOR, INC.

**Support Information**

```
ETH_ENABLE_DATA_BIT = [D2];
INF_RED_ENABLE_DATA_BIT = [D3];
FLASH_CFG_ENABLE_DATA_BIT = [D4];
CNT_REG_EN_PROTECT_DATA_BIT = [D5];
CONT_REG_ENABLE_DATA_BIT = [D6];
RS232_ENABLE_DATA_BIT = [D7];
PCC_ENABLE_DATA_BIT = [D8];
PCC_VCC_DATA_BIT = [D9];
PCC_VPP_DATA_BIT = [D10,D11];
HALF_WORD_DATA_BIT = [D12];
```

```
*****
"* Equations, state diagrams.
*****
"*
"* #####
"* # ##### # # ## ##### # ##### # # #####
"* # # # # # # # # # # # # # #
"* ##### # # # # # # # # # # # # # # #####
"* # # # # # ##### # # # # # # # # #
"* # # # # # # # # # # # # # # # # #
"* ##### # # # # # # # # # # # # # #
"*
*****
"* Configuration Register.
"* Gets its default pon reset values which are driven to the data bus when
"* during hard reset configuration.
"* If other values are required, this register may be written with new values
"* to become active for the next hard reset.
"* The state machines are built in a way that its power on value is changed in
"* one place - the declarations area.
*****
```

equations

```
@ifdef SLOW_PLL_LOCK {

    !PonDefault~ = !ResetConf~ #
                RGPORIn;
```

Freescale Semiconductor, Inc.

**Support Information**

}

ConfigReg.clk = SYSCLK;

state\_diagram ERB

state INTERNAL\_ARBITRATION:

if (PDA\_WRITE\_CONFIG\_REG &

(ERB\_DATA\_BIT.pin == EXTERNAL\_ARBITRATION) &

(!KA\_PON\_RESET # (ERB\_PON\_DEFAULT != INTERNAL\_ARBITRATION)) #

(KA\_PON\_RESET & (ERB\_PON\_DEFAULT == EXTERNAL\_ARBITRATION)) ) then

EXTERNAL\_ARBITRATION

else

INTERNAL\_ARBITRATION;

state EXTERNAL\_ARBITRATION:

if (PDA\_WRITE\_CONFIG\_REG &

(ERB\_DATA\_BIT.pin == INTERNAL\_ARBITRATION) &

(!KA\_PON\_RESET # (ERB\_PON\_DEFAULT != EXTERNAL\_ARBITRATION)) #

(KA\_PON\_RESET & (ERB\_PON\_DEFAULT == INTERNAL\_ARBITRATION)) ) then

INTERNAL\_ARBITRATION

else

EXTERNAL\_ARBITRATION;

\*\*\*\*\*

state\_diagram IP~

state IP\_AT\_0xFFF00000:

if (PDA\_WRITE\_CONFIG\_REG &

(IP~\_DATA\_BIT.pin == IP\_AT\_0x00000000) &

(!KA\_PON\_RESET # (IP~\_PON\_DEFAULT != IP\_AT\_0xFFF00000)) #

(KA\_PON\_RESET & (IP~\_PON\_DEFAULT == IP\_AT\_0x00000000)) ) then

IP\_AT\_0x00000000

else

IP\_AT\_0xFFF00000;

state IP\_AT\_0x00000000:

if (PDA\_WRITE\_CONFIG\_REG &

(IP~\_DATA\_BIT.pin == IP\_AT\_0xFFF00000) &

(!KA\_PON\_RESET # (IP~\_PON\_DEFAULT != IP\_AT\_0x00000000)) #

(KA\_PON\_RESET & (IP~\_PON\_DEFAULT == IP\_AT\_0xFFF00000)) ) then

IP\_AT\_0xFFF00000

else

IP\_AT\_0x00000000;



### Support Information

```
*****
state_diagram RSV2
state !RSV2_ACTIVE:
    if (PDA_WRITE_CONFIG_REG &
        (RSV2_DATA_BIT.pin == RSV2_ACTIVE) &
        (!KA_PON_RESET # (RSV2_PON_DEFAULT != !RSV2_ACTIVE)) #
        (KA_PON_RESET & (RSV2_PON_DEFAULT == RSV2_ACTIVE)) ) then
        RSV2_ACTIVE
    else
        !RSV2_ACTIVE;
state RSV2_ACTIVE:
    if (PDA_WRITE_CONFIG_REG &
        (RSV2_DATA_BIT.pin == !RSV2_ACTIVE) &
        (!KA_PON_RESET # (RSV2_PON_DEFAULT != RSV2_ACTIVE)) #
        (KA_PON_RESET & (RSV2_PON_DEFAULT == !RSV2_ACTIVE)) ) then
        !RSV2_ACTIVE
    else
        RSV2_ACTIVE;
*****
state_diagram BDIS
state BOOT_ENABLE:
    if (PDA_WRITE_CONFIG_REG &
        (BDIS_DATA_BIT.pin == BOOT_DISABLE) &
        (!KA_PON_RESET # (BDIS_PON_DEFAULT != BOOT_ENABLE)) #
        (KA_PON_RESET & (BDIS_PON_DEFAULT == BOOT_DISABLE)) ) then
        BOOT_DISABLE
    else
        BOOT_ENABLE;
state BOOT_DISABLE:
    if (PDA_WRITE_CONFIG_REG &
        (BDIS_DATA_BIT.pin == BOOT_ENABLE) &
        (!KA_PON_RESET # (BDIS_PON_DEFAULT != BOOT_DISABLE)) #
        (KA_PON_RESET & (BDIS_PON_DEFAULT == BOOT_ENABLE)) ) then
        BOOT_ENABLE
    else
        BOOT_DISABLE;
*****
state_diagram BPS
state BOOT_PORT_32:
    if (PDA_WRITE_CONFIG_REG &
```

### Support Information

```
(BPS_DATA_BIT.pin == BOOT_PORT_8) &
(!KA_PON_RESET # (BPS_PON_DEFAULT != BOOT_PORT_32)) #
(KA_PON_RESET & (BPS_PON_DEFAULT == BOOT_PORT_8)) ) then
BOOT_PORT_8
else if (PDA_WRITE_CONFIG_REG &
(BPS_DATA_BIT.pin == BOOT_PORT_16) &
(!KA_PON_RESET # (BPS_PON_DEFAULT != BOOT_PORT_32)) #
(KA_PON_RESET & (BPS_PON_DEFAULT == BOOT_PORT_16)) ) then
BOOT_PORT_16
else if (PDA_WRITE_CONFIG_REG &
(BPS_DATA_BIT.pin == BOOT_PORT_RESERVED) &
(!KA_PON_RESET # (BPS_PON_DEFAULT != BOOT_PORT_32)) #
(KA_PON_RESET & (BPS_PON_DEFAULT == BOOT_PORT_RESERVED)) ) then
BOOT_PORT_RESERVED
else
BOOT_PORT_32;
state BOOT_PORT_8:
if (PDA_WRITE_CONFIG_REG &
(BPS_DATA_BIT.pin == BOOT_PORT_32) &
(!KA_PON_RESET # (BPS_PON_DEFAULT != BOOT_PORT_8)) #
(KA_PON_RESET & (BPS_PON_DEFAULT == BOOT_PORT_32)) ) then
BOOT_PORT_32
else if (PDA_WRITE_CONFIG_REG &
(BPS_DATA_BIT.pin == BOOT_PORT_16) &
(!KA_PON_RESET # (BPS_PON_DEFAULT != BOOT_PORT_8)) #
(KA_PON_RESET & (BPS_PON_DEFAULT == BOOT_PORT_16)) ) then
BOOT_PORT_16
else if (PDA_WRITE_CONFIG_REG &
(BPS_DATA_BIT.pin == BOOT_PORT_RESERVED) &
(!KA_PON_RESET # (BPS_PON_DEFAULT != BOOT_PORT_8)) #
(KA_PON_RESET & (BPS_PON_DEFAULT == BOOT_PORT_RESERVED)) ) then
BOOT_PORT_RESERVED
else
BOOT_PORT_8;
state BOOT_PORT_16:
if (PDA_WRITE_CONFIG_REG &
(BPS_DATA_BIT.pin == BOOT_PORT_32) &
(!KA_PON_RESET # (BPS_PON_DEFAULT != BOOT_PORT_16)) #
(KA_PON_RESET & (BPS_PON_DEFAULT == BOOT_PORT_32)) ) then
BOOT_PORT_32
```

**Support Information**

```

else if (PDA_WRITE_CONFIG_REG &
        (BPS_DATA_BIT.pin == BOOT_PORT_8) &
        (!KA_PON_RESET # (BPS_PON_DEFAULT != BOOT_PORT_16)) #
        (KA_PON_RESET & (BPS_PON_DEFAULT == BOOT_PORT_8)) ) then
    BOOT_PORT_8
else if (PDA_WRITE_CONFIG_REG &
        (BPS_DATA_BIT.pin == BOOT_PORT_RESERVED) &
        (!KA_PON_RESET # (BPS_PON_DEFAULT != BOOT_PORT_16)) #
        (KA_PON_RESET & (BPS_PON_DEFAULT == BOOT_PORT_RESERVED)) ) then
    BOOT_PORT_RESERVED
else
    BOOT_PORT_16;
state BOOT_PORT_RESERVED:
    if (PDA_WRITE_CONFIG_REG &
        (BPS_DATA_BIT.pin == BOOT_PORT_32) &
        (!KA_PON_RESET # (BPS_PON_DEFAULT != BOOT_PORT_RESERVED)) #
        (KA_PON_RESET & (BPS_PON_DEFAULT == BOOT_PORT_32)) ) then
        BOOT_PORT_32
    else if (PDA_WRITE_CONFIG_REG &
        (BPS_DATA_BIT.pin == BOOT_PORT_16) &
        (!KA_PON_RESET # (BPS_PON_DEFAULT != BOOT_PORT_RESERVED)) #
        (KA_PON_RESET & (BPS_PON_DEFAULT == BOOT_PORT_16)) ) then
        BOOT_PORT_16
    else if (PDA_WRITE_CONFIG_REG &
        (BPS_DATA_BIT.pin == BOOT_PORT_8) &
        (!KA_PON_RESET # (BPS_PON_DEFAULT != BOOT_PORT_RESERVED)) #
        (KA_PON_RESET & (BPS_PON_DEFAULT == BOOT_PORT_8)) ) then
        BOOT_PORT_8
    else
        BOOT_PORT_RESERVED;
*****
state_diagram RSV6
state !RSV6_ACTIVE:
    if (PDA_WRITE_CONFIG_REG &
        (RSV6_DATA_BIT.pin == RSV6_ACTIVE) &
        (!KA_PON_RESET # (RSV6_PON_DEFAULT != !RSV6_ACTIVE)) #
        (KA_PON_RESET & (RSV6_PON_DEFAULT == RSV6_ACTIVE)) ) then
        RSV6_ACTIVE
    else
        !RSV6_ACTIVE;

```

**Support Information**

```

state RSV2_ACTIVE:
    if (PDA_WRITE_CONFIG_REG &
        (RSV6_DATA_BIT.pin == !RSV6_ACTIVE) &
        (!KA_PON_RESET # (RSV6_PON_DEFAULT != RSV6_ACTIVE)) #
        (KA_PON_RESET & (RSV6_PON_DEFAULT == !RSV6_ACTIVE)) ) then
        !RSV6_ACTIVE
    else
        RSV6_ACTIVE;

*****
state_diagram ISB
state INT_SPACE_BASE_0x00000000:
    if (PDA_WRITE_CONFIG_REG &
        (ISB_DATA_BIT.pin == INT_SPACE_BASE_0x00F00000) &
        (!KA_PON_RESET # (ISB_PON_DEFAULT != INT_SPACE_BASE_0x00000000)) #
        (KA_PON_RESET & (ISB_PON_DEFAULT == INT_SPACE_BASE_0x00F00000)) ) then
        INT_SPACE_BASE_0x00F00000
    else if (PDA_WRITE_CONFIG_REG &
        (ISB_DATA_BIT.pin == INT_SPACE_BASE_0xFF000000) &
        (!KA_PON_RESET # (ISB_PON_DEFAULT != INT_SPACE_BASE_0x00000000)) #
        (KA_PON_RESET & (ISB_PON_DEFAULT == INT_SPACE_BASE_0xFF000000)) ) then
        INT_SPACE_BASE_0xFF000000
    else if (PDA_WRITE_CONFIG_REG &
        (ISB_DATA_BIT.pin == INT_SPACE_BASE_0xFFF00000) &
        (!KA_PON_RESET # (ISB_PON_DEFAULT != INT_SPACE_BASE_0x00000000)) #
        (KA_PON_RESET & (ISB_PON_DEFAULT == INT_SPACE_BASE_0xFFF00000)) ) then
        INT_SPACE_BASE_0xFFF00000
    else
        INT_SPACE_BASE_0x00000000;

state INT_SPACE_BASE_0x00F00000:
    if (PDA_WRITE_CONFIG_REG &
        (ISB_DATA_BIT.pin == INT_SPACE_BASE_0x00000000) &
        (!KA_PON_RESET # (ISB_PON_DEFAULT != INT_SPACE_BASE_0x00F00000)) #
        (KA_PON_RESET & (ISB_PON_DEFAULT == INT_SPACE_BASE_0x00000000)) ) then
        INT_SPACE_BASE_0x00000000
    else if (PDA_WRITE_CONFIG_REG &
        (ISB_DATA_BIT.pin == INT_SPACE_BASE_0xFF000000) &
        (!KA_PON_RESET # (ISB_PON_DEFAULT != INT_SPACE_BASE_0x00F00000)) #
        (KA_PON_RESET & (ISB_PON_DEFAULT == INT_SPACE_BASE_0xFF000000)) ) then

```

### Support Information

```
INT_SPACE_BASE_0xFF000000
else if (PDA_WRITE_CONFIG_REG &
        (ISB_DATA_BIT.pin == INT_SPACE_BASE_0xFFF00000) &
        (!KA_PON_RESET # (ISB_PON_DEFAULT != INT_SPACE_BASE_0x00F00000)) #
        (KA_PON_RESET & (ISB_PON_DEFAULT == INT_SPACE_BASE_0xFFF00000)) ) then
    INT_SPACE_BASE_0xFFF00000
else
    INT_SPACE_BASE_0x00F00000;

state INT_SPACE_BASE_0xFF000000:
    if (PDA_WRITE_CONFIG_REG &
        (ISB_DATA_BIT.pin == INT_SPACE_BASE_0x00000000) &
        (!KA_PON_RESET # (ISB_PON_DEFAULT != INT_SPACE_BASE_0xFF000000)) #
        (KA_PON_RESET & (ISB_PON_DEFAULT == INT_SPACE_BASE_0x00000000)) ) then
        INT_SPACE_BASE_0x00000000
    else if (PDA_WRITE_CONFIG_REG &
        (ISB_DATA_BIT.pin == INT_SPACE_BASE_0x00F00000) &
        (!KA_PON_RESET # (ISB_PON_DEFAULT != INT_SPACE_BASE_0xFF000000)) #
        (KA_PON_RESET & (ISB_PON_DEFAULT == INT_SPACE_BASE_0x00F00000)) ) then
        INT_SPACE_BASE_0x00F00000
    else if (PDA_WRITE_CONFIG_REG &
        (ISB_DATA_BIT.pin == INT_SPACE_BASE_0xFFF00000) &
        (!KA_PON_RESET # (ISB_PON_DEFAULT != INT_SPACE_BASE_0xFF000000)) #
        (KA_PON_RESET & (ISB_PON_DEFAULT == INT_SPACE_BASE_0xFFF00000)) ) then
        INT_SPACE_BASE_0xFFF00000
    else
        INT_SPACE_BASE_0xFF000000;

state INT_SPACE_BASE_0xFFF00000:
    if (PDA_WRITE_CONFIG_REG &
        (ISB_DATA_BIT.pin == INT_SPACE_BASE_0x00000000) &
        (!KA_PON_RESET # (ISB_PON_DEFAULT != INT_SPACE_BASE_0xFFF00000)) #
        (KA_PON_RESET & (ISB_PON_DEFAULT == INT_SPACE_BASE_0x00000000)) ) then
        INT_SPACE_BASE_0x00000000
    else if (PDA_WRITE_CONFIG_REG &
        (ISB_DATA_BIT.pin == INT_SPACE_BASE_0x00F00000) &
        (!KA_PON_RESET # (ISB_PON_DEFAULT != INT_SPACE_BASE_0xFFF00000)) #
        (KA_PON_RESET & (ISB_PON_DEFAULT == INT_SPACE_BASE_0x00F00000)) ) then
        INT_SPACE_BASE_0x00F00000
    else if (PDA_WRITE_CONFIG_REG &
```

**Support Information**

```
(ISB_DATA_BIT.pin == INT_SPACE_BASE_0xFF000000) &
(!KA_PON_RESET # (ISB_PON_DEFAULT != INT_SPACE_BASE_0xFFFF0000)) #
(KA_PON_RESET & (ISB_PON_DEFAULT == INT_SPACE_BASE_0xFF000000)) ) then
INT_SPACE_BASE_0xFF000000
else
INT_SPACE_BASE_0xFFFF0000;
*****
state_diagram DBGC
state DEBUG_PINS_PCMCIA_2:
if (PDA_WRITE_CONFIG_REG &
(DBGC_DATA_BIT.pin == DEBUG_PINS_WATCH_POINTS) &
(!KA_PON_RESET # (DBGC_PON_DEFAULT != DEBUG_PINS_PCMCIA_2)) #
(KA_PON_RESET & (DBGC_PON_DEFAULT == DEBUG_PINS_WATCH_POINTS)) ) then
DEBUG_PINS_WATCH_POINTS
else if (PDA_WRITE_CONFIG_REG &
(DBGC_DATA_BIT.pin == DEBUG_PINS_RESREVED) &
(!KA_PON_RESET # (DBGC_PON_DEFAULT != DEBUG_PINS_PCMCIA_2)) #
(KA_PON_RESET & (DBGC_PON_DEFAULT == DEBUG_PINS_RESREVED)) ) then
DEBUG_PINS_RESREVED
else if (PDA_WRITE_CONFIG_REG &
(DBGC_DATA_BIT.pin == DEBUG_PINS_FOR_SHOW) &
(!KA_PON_RESET # (DBGC_PON_DEFAULT != DEBUG_PINS_PCMCIA_2)) #
(KA_PON_RESET & (DBGC_PON_DEFAULT == DEBUG_PINS_FOR_SHOW)) ) then
DEBUG_PINS_FOR_SHOW
else
DEBUG_PINS_PCMCIA_2;

state DEBUG_PINS_WATCH_POINTS:
if (PDA_WRITE_CONFIG_REG &
(DBGC_DATA_BIT.pin == DEBUG_PINS_PCMCIA_2) &
(!KA_PON_RESET # (DBGC_PON_DEFAULT != DEBUG_PINS_WATCH_POINTS)) #
(KA_PON_RESET & (DBGC_PON_DEFAULT == DEBUG_PINS_PCMCIA_2)) ) then
DEBUG_PINS_PCMCIA_2
else if (PDA_WRITE_CONFIG_REG &
(DBGC_DATA_BIT.pin == DEBUG_PINS_RESREVED) &
(!KA_PON_RESET # (DBGC_PON_DEFAULT != DEBUG_PINS_WATCH_POINTS)) #
(KA_PON_RESET & (DBGC_PON_DEFAULT == DEBUG_PINS_RESREVED)) ) then
DEBUG_PINS_RESREVED
else if (PDA_WRITE_CONFIG_REG &
(DBGC_DATA_BIT.pin == DEBUG_PINS_FOR_SHOW) &
```

## Support Information

```
(!KA_PON_RESET # (DBG_C_PON_DEFAULT != DEBUG_PINS_WATCH_POINTS)) #
(KA_PON_RESET & (DBG_C_PON_DEFAULT == DEBUG_PINS_FOR_SHOW)) ) then
DEBUG_PINS_FOR_SHOW
else
DEBUG_PINS_WATCH_POINTS;

state DEBUG_PINS_RESREVED:
if (PDA_WRITE_CONFIG_REG &
(DBG_C_DATA_BIT.pin == DEBUG_PINS_PCMCIA_2) &
(!KA_PON_RESET # (DBG_C_PON_DEFAULT != DEBUG_PINS_RESREVED)) #
(KA_PON_RESET & (DBG_C_PON_DEFAULT == DEBUG_PINS_PCMCIA_2)) ) then
DEBUG_PINS_PCMCIA_2
else if (PDA_WRITE_CONFIG_REG &
(DBG_C_DATA_BIT.pin == DEBUG_PINS_WATCH_POINTS) &
(!KA_PON_RESET # (DBG_C_PON_DEFAULT != DEBUG_PINS_RESREVED)) #
(KA_PON_RESET & (DBG_C_PON_DEFAULT == DEBUG_PINS_WATCH_POINTS)) ) then
DEBUG_PINS_WATCH_POINTS
else if (PDA_WRITE_CONFIG_REG &
(DBG_C_DATA_BIT.pin == DEBUG_PINS_FOR_SHOW) &
(!KA_PON_RESET # (DBG_C_PON_DEFAULT != DEBUG_PINS_RESREVED)) #
(KA_PON_RESET & (DBG_C_PON_DEFAULT == DEBUG_PINS_FOR_SHOW)) ) then
DEBUG_PINS_FOR_SHOW
else
DEBUG_PINS_RESREVED;

state DEBUG_PINS_FOR_SHOW:
if (PDA_WRITE_CONFIG_REG &
(DBG_C_DATA_BIT.pin == DEBUG_PINS_PCMCIA_2) &
(!KA_PON_RESET # (DBG_C_PON_DEFAULT != DEBUG_PINS_FOR_SHOW)) #
(KA_PON_RESET & (DBG_C_PON_DEFAULT == DEBUG_PINS_PCMCIA_2)) ) then
DEBUG_PINS_PCMCIA_2
else if (PDA_WRITE_CONFIG_REG &
(DBG_C_DATA_BIT.pin == DEBUG_PINS_WATCH_POINTS) &
(!KA_PON_RESET # (DBG_C_PON_DEFAULT != DEBUG_PINS_FOR_SHOW)) #
(KA_PON_RESET & (DBG_C_PON_DEFAULT == DEBUG_PINS_WATCH_POINTS)) ) then
DEBUG_PINS_WATCH_POINTS
else if (PDA_WRITE_CONFIG_REG &
(DBG_C_DATA_BIT.pin == DEBUG_PINS_RESREVED) &
(!KA_PON_RESET # (DBG_C_PON_DEFAULT != DEBUG_PINS_FOR_SHOW)) #
(KA_PON_RESET & (DBG_C_PON_DEFAULT == DEBUG_PINS_RESREVED)) ) then
DEBUG_PINS_RESREVED
```

### Support Information

```
else
    DEBUG_PINS_FOR_SHOW;
*****
state_diagram DBPC
state DEBUG_PORT_ON_JTAG:
    if (PDA_WRITE_CONFIG_REG &
        (DBPC_DATA_BIT.pin == DEBUG_PORT_NON_EXISTANT) &
        (!KA_PON_RESET # (DBPC_PON_DEFAULT != DEBUG_PORT_ON_JTAG)) #
        (KA_PON_RESET & (DBPC_PON_DEFAULT == DEBUG_PORT_NON_EXISTANT)) ) then
        DEBUG_PORT_NON_EXISTANT
    else if (PDA_WRITE_CONFIG_REG &
        (DBPC_DATA_BIT.pin == DEBUG_PORT_RESERVED) &
        (!KA_PON_RESET # (DBPC_PON_DEFAULT != DEBUG_PORT_ON_JTAG)) #
        (KA_PON_RESET & (DBPC_PON_DEFAULT == DEBUG_PORT_RESERVED)) ) then
        DEBUG_PORT_RESERVED
    else if (PDA_WRITE_CONFIG_REG &
        (DBPC_DATA_BIT.pin == DEBUG_PORT_ON_DEBUG_PINS) &
        (!KA_PON_RESET # (DBPC_PON_DEFAULT != DEBUG_PORT_ON_JTAG)) #
        (KA_PON_RESET & (DBPC_PON_DEFAULT == DEBUG_PORT_ON_DEBUG_PINS)) ) then
        DEBUG_PORT_ON_DEBUG_PINS
    else
        DEBUG_PORT_ON_JTAG;

state DEBUG_PORT_NON_EXISTANT:
    if (PDA_WRITE_CONFIG_REG &
        (DBPC_DATA_BIT.pin == DEBUG_PORT_ON_JTAG) &
        (!KA_PON_RESET # (DBPC_PON_DEFAULT != DEBUG_PORT_NON_EXISTANT)) #
        (KA_PON_RESET & (DBPC_PON_DEFAULT == DEBUG_PORT_ON_JTAG)) ) then
        DEBUG_PORT_ON_JTAG
    else if (PDA_WRITE_CONFIG_REG &
        (DBPC_DATA_BIT.pin == DEBUG_PORT_RESERVED) &
        (!KA_PON_RESET # (DBPC_PON_DEFAULT != DEBUG_PORT_NON_EXISTANT)) #
        (KA_PON_RESET & (DBPC_PON_DEFAULT == DEBUG_PORT_RESERVED)) ) then
        DEBUG_PORT_RESERVED
    else if (PDA_WRITE_CONFIG_REG &
        (DBPC_DATA_BIT.pin == DEBUG_PORT_ON_DEBUG_PINS) &
        (!KA_PON_RESET # (DBPC_PON_DEFAULT != DEBUG_PORT_NON_EXISTANT)) #
        (KA_PON_RESET & (DBPC_PON_DEFAULT == DEBUG_PORT_ON_DEBUG_PINS)) ) then
        DEBUG_PORT_ON_DEBUG_PINS
    else
```



## Support Information

```
DEBUG_PORT_NON_EXISTANT;

state DEBUG_PORT_RESERVED:
    if (PDA_WRITE_CONFIG_REG &
        (DBPC_DATA_BIT.pin == DEBUG_PORT_ON_JTAG) &
        (!KA_PON_RESET # (DBPC_PON_DEFAULT != DEBUG_PORT_RESERVED)) #
        (KA_PON_RESET & (DBPC_PON_DEFAULT == DEBUG_PORT_ON_JTAG)) ) then
        DEBUG_PORT_ON_JTAG
    else if (PDA_WRITE_CONFIG_REG &
        (DBPC_DATA_BIT.pin == DEBUG_PORT_NON_EXISTANT) &
        (!KA_PON_RESET # (DBPC_PON_DEFAULT != DEBUG_PORT_RESERVED)) #
        (KA_PON_RESET & (DBPC_PON_DEFAULT == DEBUG_PORT_NON_EXISTANT)) ) then
        DEBUG_PORT_NON_EXISTANT
    else if (PDA_WRITE_CONFIG_REG &
        (DBPC_DATA_BIT.pin == DEBUG_PORT_ON_DEBUG_PINS) &
        (!KA_PON_RESET # (DBPC_PON_DEFAULT != DEBUG_PORT_RESERVED)) #
        (KA_PON_RESET & (DBPC_PON_DEFAULT == DEBUG_PORT_ON_DEBUG_PINS)) ) then
        DEBUG_PORT_ON_DEBUG_PINS
    else
        DEBUG_PORT_RESERVED;

state DEBUG_PORT_ON_DEBUG_PINS:
    if (PDA_WRITE_CONFIG_REG &
        (DBPC_DATA_BIT.pin == DEBUG_PORT_ON_JTAG) &
        (!KA_PON_RESET # (DBPC_PON_DEFAULT != DEBUG_PORT_ON_DEBUG_PINS)) #
        (KA_PON_RESET & (DBPC_PON_DEFAULT == DEBUG_PORT_ON_JTAG)) ) then
        DEBUG_PORT_ON_JTAG
    else if (PDA_WRITE_CONFIG_REG &
        (DBPC_DATA_BIT.pin == DEBUG_PORT_NON_EXISTANT) &
        (!KA_PON_RESET # (DBPC_PON_DEFAULT != DEBUG_PORT_ON_DEBUG_PINS)) #
        (KA_PON_RESET & (DBPC_PON_DEFAULT == DEBUG_PORT_NON_EXISTANT)) ) then
        DEBUG_PORT_NON_EXISTANT
    else if (PDA_WRITE_CONFIG_REG &
        (DBPC_DATA_BIT.pin == DEBUG_PORT_RESERVED) &
        (!KA_PON_RESET # (DBPC_PON_DEFAULT != DEBUG_PORT_ON_DEBUG_PINS)) #
        (KA_PON_RESET & (DBPC_PON_DEFAULT == DEBUG_PORT_RESERVED)) ) then
        DEBUG_PORT_RESERVED
    else
        DEBUG_PORT_ON_DEBUG_PINS;
```

### Support Information

```
*****
state_diagram RSV13
state !RSV13_ACTIVE:
    if (PDA_WRITE_CONFIG_REG &
        (RSV13_DATA_BIT.pin == RSV13_ACTIVE) &
        (!KA_PON_RESET # (RSV13_PON_DEFAULT != !RSV13_ACTIVE)) #
        (KA_PON_RESET & (RSV13_PON_DEFAULT == RSV13_ACTIVE)) ) then
        RSV13_ACTIVE
    else
        !RSV13_ACTIVE;
state RSV13_ACTIVE:
    if (PDA_WRITE_CONFIG_REG &
        (RSV13_DATA_BIT.pin == !RSV13_ACTIVE) &
        (!KA_PON_RESET # (RSV13_PON_DEFAULT != RSV13_ACTIVE)) #
        (KA_PON_RESET & (RSV13_PON_DEFAULT == !RSV13_ACTIVE)) ) then
        !RSV13_ACTIVE
    else
        RSV13_ACTIVE;
*****
state_diagram RSV14
state !RSV14_ACTIVE:
    if (PDA_WRITE_CONFIG_REG &
        (RSV14_DATA_BIT.pin == RSV14_ACTIVE) &
        (!KA_PON_RESET # (RSV14_PON_DEFAULT != !RSV14_ACTIVE)) #
        (KA_PON_RESET & (RSV14_PON_DEFAULT == RSV14_ACTIVE)) ) then
        RSV14_ACTIVE
    else
        !RSV14_ACTIVE;
state RSV14_ACTIVE:
    if (PDA_WRITE_CONFIG_REG &
        (RSV14_DATA_BIT.pin == !RSV14_ACTIVE) &
        (!KA_PON_RESET # (RSV14_PON_DEFAULT != RSV14_ACTIVE)) #
        (KA_PON_RESET & (RSV14_PON_DEFAULT == !RSV14_ACTIVE)) ) then
        !RSV14_ACTIVE
    else
        RSV14_ACTIVE;
*****
state_diagram RSV15
state !RSV15_ACTIVE:
    if (PDA_WRITE_CONFIG_REG &
```

**Support Information**

```

(RSV15_DATA_BIT.pin == RSV15_ACTIVE) &
    (!KA_PON_RESET # (RSV15_PON_DEFAULT != !RSV15_ACTIVE)) #
    (KA_PON_RESET & (RSV15_PON_DEFAULT == RSV15_ACTIVE)) ) then
    RSV15_ACTIVE
else
    !RSV15_ACTIVE;

state RSV15_ACTIVE:
    if (PDA_WRITE_CONFIG_REG &
        (RSV15_DATA_BIT.pin == !RSV15_ACTIVE) &
        (!KA_PON_RESET # (RSV15_PON_DEFAULT != RSV15_ACTIVE)) #
        (KA_PON_RESET & (RSV15_PON_DEFAULT == !RSV15_ACTIVE)) ) then
        !RSV15_ACTIVE
    else
        RSV15_ACTIVE;

*****
** Control Register.
*****

equations

WideContReg.clk = SYSCLK;
DrivenContReg.oe = ^hfff;

state_diagram FlashEn~
    state FLASH_ENABLED:
        if (PDA_WRITE_CONTROL_REG1 &
            (FLASH_ENABLE_DATA_BIT.pin == !FLASH_ENABLED) &
            (!KA_PON_RESET # (FLASH_ENABLE_PON_DEFAULT != FLASH_ENABLED)) #
            (KA_PON_RESET & (FLASH_ENABLE_PON_DEFAULT == !FLASH_ENABLED)) ) then
            !FLASH_ENABLED
        else
            FLASH_ENABLED;

    state !FLASH_ENABLED:
        if (PDA_WRITE_CONTROL_REG1 &
            (FLASH_ENABLE_DATA_BIT.pin == FLASH_ENABLED) &
            (!KA_PON_RESET # (FLASH_ENABLE_PON_DEFAULT != !FLASH_ENABLED)) #
            (KA_PON_RESET & (FLASH_ENABLE_PON_DEFAULT == FLASH_ENABLED)) ) then
            FLASH_ENABLED
        else
            !FLASH_ENABLED;

*****

```

**Support Information**

```

state_diagram DramEn~
state DRAM_ENABLED:
    if (PDA_WRITE_CONTROL_REG1 &
        (DRAM_ENABLE_DATA_BIT.pin == !DRAM_ENABLED) &
        (!KA_PON_RESET # (DRAM_ENABLE_PON_DEFAULT != DRAM_ENABLED)) #
        (KA_PON_RESET & (DRAM_ENABLE_PON_DEFAULT == !DRAM_ENABLED)) ) then
        !DRAM_ENABLED
    else
        DRAM_ENABLED;
state !DRAM_ENABLED:
    if (PDA_WRITE_CONTROL_REG1 &
        (DRAM_ENABLE_DATA_BIT.pin == DRAM_ENABLED) &
        (!KA_PON_RESET # (DRAM_ENABLE_PON_DEFAULT != !DRAM_ENABLED)) #
        (KA_PON_RESET & (DRAM_ENABLE_PON_DEFAULT == DRAM_ENABLED)) ) then
        DRAM_ENABLED
    else
        !DRAM_ENABLED;

*****
state_diagram EthEn~
state ETH_ENABLED:
    if (PDA_WRITE_CONTROL_REG1 &
        (ETH_ENABLE_DATA_BIT.pin == !ETH_ENABLED) &
        (!KA_PON_RESET # (ETH_ENABLE_PON_DEFAULT != ETH_ENABLED)) #
        (KA_PON_RESET & (ETH_ENABLE_PON_DEFAULT == !ETH_ENABLED)) ) then
        !ETH_ENABLED
    else
        ETH_ENABLED;
state !ETH_ENABLED:
    if (PDA_WRITE_CONTROL_REG1 &
        (ETH_ENABLE_DATA_BIT.pin == ETH_ENABLED) &
        (!KA_PON_RESET # (ETH_ENABLE_PON_DEFAULT != !ETH_ENABLED)) #
        (KA_PON_RESET & (ETH_ENABLE_PON_DEFAULT == ETH_ENABLED)) ) then
        ETH_ENABLED
    else
        !ETH_ENABLED;

*****
state_diagram InfRedEn~
state INF_RED_ENABLE:
    if (PDA_WRITE_CONTROL_REG1 &

```

Freescale Semiconductor, Inc.

### Support Information

```
(INF_RED_ENABLE_DATA_BIT.pin == !INF_RED_ENABLE) &
(!KA_PON_RESET # (INF_RED_ENABLE_PON_DEFAULT != INF_RED_ENABLE)) #
(KA_PON_RESET & (INF_RED_ENABLE_PON_DEFAULT == !INF_RED_ENABLE)) ) then
!INF_RED_ENABLE
else
    INF_RED_ENABLE;
state !INF_RED_ENABLE:
    if (PDA_WRITE_CONTROL_REG1 &
        (INF_RED_ENABLE_DATA_BIT.pin == INF_RED_ENABLE) &
        (!KA_PON_RESET # (INF_RED_ENABLE_PON_DEFAULT != !INF_RED_ENABLE)) #
        (KA_PON_RESET & (INF_RED_ENABLE_PON_DEFAULT == INF_RED_ENABLE)) ) then
        INF_RED_ENABLE
    else
        !INF_RED_ENABLE;
*****
state_diagram FlashCfgEn~
state FLASH_CFG_ENABLE:
    if (PDA_WRITE_CONTROL_REG1 &
        (FLASH_CFG_ENABLE_DATA_BIT.pin == !FLASH_CFG_ENABLE) &
        (!KA_PON_RESET # (FLASH_CFG_ENABLE_PON_DEFAULT != FLASH_CFG_ENABLE)) #
        (KA_PON_RESET & (FLASH_CFG_ENABLE_PON_DEFAULT == !FLASH_CFG_ENABLE)) ) then
        !FLASH_CFG_ENABLE
    else
        FLASH_CFG_ENABLE;
state !FLASH_CFG_ENABLE:
    if (PDA_WRITE_CONTROL_REG1 &
        (FLASH_CFG_ENABLE_DATA_BIT.pin == FLASH_CFG_ENABLE) &
        (!KA_PON_RESET # (FLASH_CFG_ENABLE_PON_DEFAULT != !FLASH_CFG_ENABLE)) #
        (KA_PON_RESET & (FLASH_CFG_ENABLE_PON_DEFAULT == FLASH_CFG_ENABLE)) ) then
        FLASH_CFG_ENABLE
    else
        !FLASH_CFG_ENABLE;
*****
"* To avoid in advertant write to the Control Register Enable bit, which might
"* result in a need to re-power the board - protection logic is provided.
"* In order of writing the Control Register Enable this bit in the status register
"* must be negated. After any write to the control register, this bit asserts
"* again (to protected mode)
*****
equations
```

**Support Information**

```

CntRegEnProtect~.clk = SYSCLK;

state_diagram CntRegEnProtect~
  state CNT_REG_EN_PROTECT:
    if (PDA_WRITE_CONTROL_REG2 &
        (CNT_REG_EN_PROTECT_DATA_BIT.pin == !CNT_REG_EN_PROTECT) &
        (!KA_PON_RESET # (CNT_REG_EN_PROTECT_PON_DEFAULT != CNT_REG_EN_PROTECT)) #
        (KA_PON_RESET & (CNT_REG_EN_PROTECT_PON_DEFAULT == !CNT_REG_EN_PROTECT)) ) then
        !CNT_REG_EN_PROTECT
    else
        CNT_REG_EN_PROTECT;
  state !CNT_REG_EN_PROTECT:
    if (PDA_WRITE_CONTROL_REG2 &
        (CNT_REG_EN_PROTECT_DATA_BIT.pin == CNT_REG_EN_PROTECT) &
        (!KA_PON_RESET # (CNT_REG_EN_PROTECT_PON_DEFAULT != !CNT_REG_EN_PROTECT)) #
        (KA_PON_RESET & (CNT_REG_EN_PROTECT_PON_DEFAULT == CNT_REG_EN_PROTECT)) #
        PDA_WRITE_CONTROL_REG1) then " any write to control reg 1
        CNT_REG_EN_PROTECT
    else
        !CNT_REG_EN_PROTECT;
  *****
  "* protected by CntRegEnProtect~ to prevent from inadvertant write
  *****
state_diagram CntRegEn~
  state CONT_REG_ENABLE:
    if (PDA_WRITE_CONTROL_REG1 & (CntRegEnProtect~.fb != CNT_REG_EN_PROTECT) &
        (CONT_REG_ENABLE_DATA_BIT.pin == !CONT_REG_ENABLE) &
        (!KA_PON_RESET # (CONT_REG_ENABLE_PON_DEFAULT != CONT_REG_ENABLE)) #
        (KA_PON_RESET & (CONT_REG_ENABLE_PON_DEFAULT == !CONT_REG_ENABLE)) ) then
        !CONT_REG_ENABLE
    else
        CONT_REG_ENABLE;
  state !CONT_REG_ENABLE:" in fact not applicable
    if (PDA_WRITE_CONTROL_REG1 &
        (CONT_REG_ENABLE_DATA_BIT.pin == CONT_REG_ENABLE) &
        (!KA_PON_RESET # (CONT_REG_ENABLE_PON_DEFAULT != !CONT_REG_ENABLE)) #
        (KA_PON_RESET & (CONT_REG_ENABLE_PON_DEFAULT == CONT_REG_ENABLE)) ) then
        CONT_REG_ENABLE
    else

```

## Support Information

```
!CONT_REG_ENABLE;

*****
state_diagram RS232En~
state RS232_ENABLE:
    if (PDA_WRITE_CONTROL_REG1 &
        (RS232_ENABLE_DATA_BIT.pin == !RS232_ENABLE) &
        (!KA_PON_RESET # (RS232_ENABLE_PON_DEFAULT != RS232_ENABLE)) #
        (KA_PON_RESET & (RS232_ENABLE_PON_DEFAULT == !RS232_ENABLE)) ) then
        !RS232_ENABLE
    else
        RS232_ENABLE;
state !RS232_ENABLE:
    if (PDA_WRITE_CONTROL_REG1 &
        (RS232_ENABLE_DATA_BIT.pin == RS232_ENABLE) &
        (!KA_PON_RESET # (RS232_ENABLE_PON_DEFAULT != !RS232_ENABLE)) #
        (KA_PON_RESET & (RS232_ENABLE_PON_DEFAULT == RS232_ENABLE)) ) then
        RS232_ENABLE
    else
        !RS232_ENABLE;
*****
state_diagram PccEn~
state PCC_ENABLE:
    if (PDA_WRITE_CONTROL_REG1 &
        (PCC_ENABLE_DATA_BIT.pin == !PCC_ENABLE) &
        (!KA_PON_RESET # (PCC_ENABLE_PON_DEFAULT != PCC_ENABLE)) #
        (KA_PON_RESET & (PCC_ENABLE_PON_DEFAULT == !PCC_ENABLE)) ) then
        !PCC_ENABLE
    else
        PCC_ENABLE;
state !PCC_ENABLE:
    if (PDA_WRITE_CONTROL_REG1 &
        (PCC_ENABLE_DATA_BIT.pin == PCC_ENABLE) &
        (!KA_PON_RESET # (PCC_ENABLE_PON_DEFAULT != !PCC_ENABLE)) #
        (KA_PON_RESET & (PCC_ENABLE_PON_DEFAULT == PCC_ENABLE)) ) then
        PCC_ENABLE
    else
        !PCC_ENABLE;
```

**Support Information**

```

*****
state_diagram PccVccOn~
state PCC_VCC_ON:
    if (PDA_WRITE_CONTROL_REG1 &
        (PCC_VCC_DATA_BIT.pin == !PCC_VCC_ON) &
        (!KA_PON_RESET # (PCC_VCC_PON_DEFAULT != PCC_VCC_ON)) #
        (KA_PON_RESET & (PCC_VCC_PON_DEFAULT == !PCC_VCC_ON)) ) then
        !PCC_VCC_ON
    else
        PCC_VCC_ON;
state !PCC_VCC_ON:
    if (PDA_WRITE_CONTROL_REG1 &
        (PCC_VCC_DATA_BIT.pin == PCC_VCC_ON) &
        (!KA_PON_RESET # (PCC_VCC_PON_DEFAULT != !PCC_VCC_ON)) #
        (KA_PON_RESET & (PCC_VCC_PON_DEFAULT == PCC_VCC_ON)) ) then
        PCC_VCC_ON
    else
        !PCC_VCC_ON;
*****

state_diagram PccVpp
state PCC_VPP_0:
    if (PDA_WRITE_CONTROL_REG1 &
        (PCC_VPP_DATA_BIT.pin == PCC_VPP_12) &
        (!KA_PON_RESET # (PCC_VPP_PON_DEFAULT != PCC_VPP_0)) #
        (KA_PON_RESET & (PCC_VPP_PON_DEFAULT == PCC_VPP_12)) ) then
        PCC_VPP_12
    else if (PDA_WRITE_CONTROL_REG1 &
        (PCC_VPP_DATA_BIT.pin == PCC_VPP_5) &
        (!KA_PON_RESET # (PCC_VPP_PON_DEFAULT != PCC_VPP_0)) #
        (KA_PON_RESET & (PCC_VPP_PON_DEFAULT == PCC_VPP_5)) ) then
        PCC_VPP_5
    else if (PDA_WRITE_CONTROL_REG1 &
        (PCC_VPP_DATA_BIT.pin == PCC_VPP_TS) &
        (!KA_PON_RESET # (PCC_VPP_PON_DEFAULT != PCC_VPP_0)) #
        (KA_PON_RESET & (PCC_VPP_PON_DEFAULT == PCC_VPP_TS)) ) then
        PCC_VPP_TS
    else
        PCC_VPP_0;
state PCC_VPP_12:
    if (PDA_WRITE_CONTROL_REG1 &

```



### Support Information

```
(PCC_VPP_DATA_BIT.pin == PCC_VPP_0) &
(!KA_PON_RESET # (PCC_VPP_PON_DEFAULT != PCC_VPP_12)) #
(KA_PON_RESET & (PCC_VPP_PON_DEFAULT == PCC_VPP_0)) ) then
PCC_VPP_0
else if (PDA_WRITE_CONTROL_REG1 &
(PCC_VPP_DATA_BIT.pin == PCC_VPP_5) &
(!KA_PON_RESET # (PCC_VPP_PON_DEFAULT != PCC_VPP_12)) #
(KA_PON_RESET & (PCC_VPP_PON_DEFAULT == PCC_VPP_5)) ) then
PCC_VPP_5
else if (PDA_WRITE_CONTROL_REG1 &
(PCC_VPP_DATA_BIT.pin == PCC_VPP_TS) &
(!KA_PON_RESET # (PCC_VPP_PON_DEFAULT != PCC_VPP_12)) #
(KA_PON_RESET & (PCC_VPP_PON_DEFAULT == PCC_VPP_TS)) ) then
PCC_VPP_TS
else
PCC_VPP_12;
state PCC_VPP_5:
if (PDA_WRITE_CONTROL_REG1 &
(PCC_VPP_DATA_BIT.pin == PCC_VPP_0) &
(!KA_PON_RESET # (PCC_VPP_PON_DEFAULT != PCC_VPP_5)) #
(KA_PON_RESET & (PCC_VPP_PON_DEFAULT == PCC_VPP_0)) ) then
PCC_VPP_0
else if (PDA_WRITE_CONTROL_REG1 &
(PCC_VPP_DATA_BIT.pin == PCC_VPP_12) &
(!KA_PON_RESET # (PCC_VPP_PON_DEFAULT != PCC_VPP_5)) #
(KA_PON_RESET & (PCC_VPP_PON_DEFAULT == PCC_VPP_12)) ) then
PCC_VPP_12
else if (PDA_WRITE_CONTROL_REG1 &
(PCC_VPP_DATA_BIT.pin == PCC_VPP_TS) &
(!KA_PON_RESET # (PCC_VPP_PON_DEFAULT != PCC_VPP_5)) #
(KA_PON_RESET & (PCC_VPP_PON_DEFAULT == PCC_VPP_TS)) ) then
PCC_VPP_TS
else
PCC_VPP_5;
state PCC_VPP_TS:
if (PDA_WRITE_CONTROL_REG1 &
(PCC_VPP_DATA_BIT.pin == PCC_VPP_0) &
(!KA_PON_RESET # (PCC_VPP_PON_DEFAULT != PCC_VPP_TS)) #
(KA_PON_RESET & (PCC_VPP_PON_DEFAULT == PCC_VPP_0)) ) then
PCC_VPP_0
```

**Support Information**

```

else if (PDA_WRITE_CONTROL_REG1 &
        (PCC_VPP_DATA_BIT.pin == PCC_VPP_12) &
        (!KA_PON_RESET # (PCC_VPP_PON_DEFAULT != PCC_VPP_TS)) #
        (KA_PON_RESET & (PCC_VPP_PON_DEFAULT == PCC_VPP_12)) ) then
    PCC_VPP_12
else if (PDA_WRITE_CONTROL_REG1 &
        (PCC_VPP_DATA_BIT.pin == PCC_VPP_5) &
        (!KA_PON_RESET # (PCC_VPP_PON_DEFAULT != PCC_VPP_TS)) #
        (KA_PON_RESET & (PCC_VPP_PON_DEFAULT == PCC_VPP_5)) ) then
    PCC_VPP_5
else
    PCC_VPP_TS;
*****
state_diagram HalfWord~
state HALF_WORD:
    if (PDA_WRITE_CONTROL_REG1 &
        (HALF_WORD_DATA_BIT.pin == !HALF_WORD) &
        (!KA_PON_RESET # (HALF_WORD_PON_DEFAULT != HALF_WORD)) #
        (KA_PON_RESET & (HALF_WORD_PON_DEFAULT == !HALF_WORD)) ) then
        !HALF_WORD
    else
        HALF_WORD;
state !HALF_WORD:
    if (PDA_WRITE_CONTROL_REG1 &
        (HALF_WORD_DATA_BIT.pin == HALF_WORD) &
        (!KA_PON_RESET # (HALF_WORD_PON_DEFAULT != !HALF_WORD)) #
        (KA_PON_RESET & (HALF_WORD_PON_DEFAULT == HALF_WORD)) ) then
        HALF_WORD
    else
        !HALF_WORD;
*****
/* Read Registers.
/* All registers have read capabilty.
*****
equations
DataOe = PDA_READ #
        RESET_CONFIG_DRIVEN;
Data.oe = DataOe;

when (PDA_READ_CONFIG_REG #

```

### Support Information

```
RESET_CONFIG_DRIVEN) then
Data = [ERB.fb,IP~.fb,RSV2.fb,BDIS.fb,BPS0.fb,BPS1.fb,RSV6.fb,
        ISB0.fb,ISB1.fb,DBGC0.fb,DBGC1.fb,DBPC0.fb,DBPC1.fb,
        RSV13.fb,RSV14.fb,RSV15.fb];
else when (PDA_READ_CONTROL_REG1) then
    Data = ReadContReg1;
else when (PDA_READ_STATUS_REG1) then
    Data = [FlashPD4,FlashPD3,FlashPD2,FlashPD1,
           DramPdEdo~,DramPD4,DramPD3,DramPD2,DramPD1,
           ExtToolI0,ExtToolI1,ExtToolI2,ExtToolI3,PccVppG~,0,0];
else when (PDA_READ_STATUS_REG2) then
    Data = [0,0,0,0,0,0,0,0,0,FlashPD7,FlashPD6,FlashPD5,0,0,1,0];
        " revision number 1 - pilot
end cnt_reg6
```

ARCHIVED BY FREESCALE SEMICONDUCTOR, INC.

**Support Information**

**APPENDIX B - ADI I/F**

The ADI parallel port supplies parallel link from the MPCADS to various host computers. This port is connected via a 37 line cable to a special board called ADI (Application Development Interface) installed in the host computer. Four versions of the ADI board are available to support connection to IBM-PC/XT/AT, MAC II, VMEbus computers and SUN-4 SPARC stations. It is possible to connect the MPC281ADS board to these computers provided that the appropriate software drivers are installed on them.

Each MPC281ADS can have 8 possible slave addresses set for its ADI port, enabling up to 8 MPC281ADS boards to be connected to the same ADI board.

The ADI port connector is a 37 pin, male, D type connector. The connection between the MPC281ADS and the host computer is by a 37 line flat cable, supplied with the ADI board. FIGURE A-1 below shows the pin configuration of the connector.

FIGURE A-1 ADI Port Connector

Gnd	20	1	N.C.
Gnd	21	2	D_C~
Gnd	22	3	HST_ACK
Gnd	23	4	ADS_SRESET
Gnd	24	5	ADS_HRESET
Gnd	25	6	ADS_SEL2
(+ 12 v) N.C.	26	7	ADS_SEL1
HOST_VCC	27	8	ADS_SEL0
HOST_VCC	28	9	HOST_REQ
HOST_VCC	29	10	ADS_REQ
HOST_ENABLE~	30	11	ADS_ACK
Gnd	31	12	N.C.
Gnd	32	13	N.C.
Gnd	33	14	N.C.
PD0	34	15	N.C.
PD2	35	16	PD1
PD4	36	17	PD3
PD6	37	18	PD5
		19	PD7

NOTE: Pin 26 on the ADI is connected to +12 v power supply, but it is not used in the MPC281ADS.

**B•1 ADI Port Signal Description**

The ADI port on the MPC281ADS was slightly modified to generate either hard reset or soft reset. This feature was added to comply with the MPC's reset mechanism.

In the list below, the directions 'I', 'O', and 'I/O' are relative to the MPC821ADS board. (I.E. 'I' means input to the MPC821ADS)

**NOTE:**

Since the ADI was originated for the DSP56001ADS some of its signals throughout the boards it was used with, were designated with the prefix "ADS". This convention is kept with this design also.

- ADS\_SEL(0:2) - 'I'

### Support Information

These three input lines determine the slave address of the MPC821ADS being accessed by the host computer. Up to 8 boards can be addressed by one ADI board.

- ADS\_SRESET - 'I'  
This input line is used to generate Soft Reset for the MPC. When an ads is selected and this line is asserted by the host computer, Soft Reset will be generated to the MPC along with the Soft Reset configuration applied during that sequence.
- HOST\_ENABLE~ - 'I'  
This line is always driven low by the ADI board. When an ADI is connected to the MPCADS, this signals enabled the operation of the debug port controller. Otherwise the debug port controller is disabled and its outputs are tri-stated.
- ADS\_HRESET - 'I'  
When a host is connected, this line is used in conjunction with the addressing lines to generate a Hard Reset to the MPC821ADS board. When this signal is driven in conjunction with the ADS\_SRESET signal, the ADI I/F state machines and registers are reset.
- HOST\_REQ - 'I'  
This signal initiates a host to MPC821ADS write cycle.
- ADS\_ACK - 'O'  
This signal is the MPC821ADS response to the HOST\_REQ signal, indicating that the board has detected the assertion of HOST\_REQ.
- ADS\_REQ - 'O'  
This signal initiates an MPC821ADS to host write cycle.
- HST\_ACK - 'I'  
This signal serves as the host's response to the ADS\_REQ signal.
- HOST\_VCC - 'I' (three lines)  
These lines are power lines from the host computer. In the MPC821ADS, these lines are used by the hardware to determine if the host computer is powered on.
- PD(0:7) - 'I/O'

These eight I/O lines are the parallel data bus. This bus is used to transmit and receive data from the host computer.

**Support Information**

**APPENDIX C - ADI Installation**

**C•1 INTRODUCTION**

This appendix describes the hardware installation of the ADI board into various host computers. The installation instructions cover the following host computers:

- 1) IBM-PC/XT/AT
- 2) SUN - 4 (SBus interface)

**C•2 IBM-PC/XT/AT to MPC821ADS Interface**

The ADI board should be installed in one of the IBM-PC/XT/AT motherboard system expansion slots. A single ADI can control up to eight MPC821ADS boards. The ADI address in the computer is configured to be at I/O memory addresses 100-102 (hex), but it may be reconfigured for an alternate address space.

**CAUTION**

BEFORE REMOVING OR INSTALLING ANY EQUIPMENT IN THE IBM-PC/XT/AT COMPUTER, TURN THE POWER OFF AND REMOVE THE POWER CORD.

**C•2•1 ADI Installation in IBM-PC/XT/AT**

Refer to the appropriate Installation and Setup manual of the IBM-PC/XT/AT computer for instructions on removing the computer cover.

The ADI board address block should be configured at a free I/O address space in the computer. The address must be unique and it must not fall within the address range of another card installed in the computer.

The ADI board address block can be configured to start at one of the three following addresses:

- \$100 - This address is unassigned in the IBM-PC
- \$200 - This address is usually used for the game port
- \$300 - This address is defined as a prototype port

The ADI board is factory configured for address decoding at 100-102 hex in the IBM-PC/XT/AT I/O address map. These are undefined peripheral addresses.

**Support Information**

**FIGURE A-1 Physical Location of jumper JG1 and JG2**

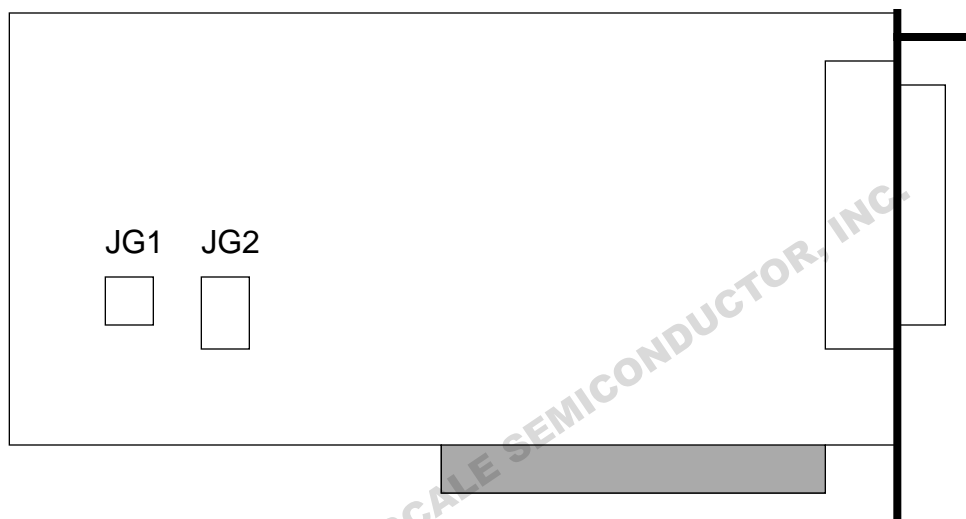

**NOTE:** Jumper JG2 should be left unconnected.

The following figure shows the required jumper connection for each address configuration. Address 0 hex is not recommended, and its usage might cause problems.

**FIGURE A-2 JG1 Configuration Options**

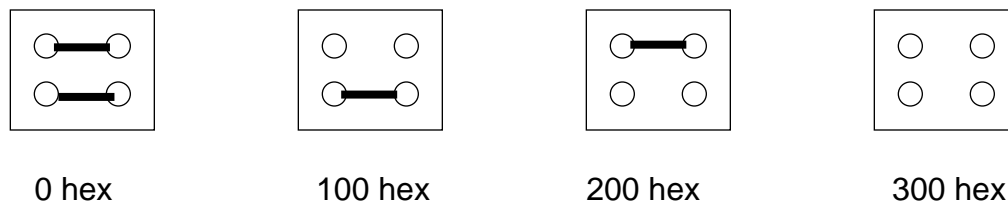

To properly install the ADI board, position its front bottom corner in the plastic card guide channel at the front of the IBM-PC/XT/AT chassis. Keeping the top of the ADI board level and any ribbon cables out of the way, lower the board until its connectors are aligned with the computer expansion slot connectors. Using evenly distributed pressure, press the ADI board straight down until it seats in the expansion slot. Secure the ADI board to the computer chassis using the bracket retaining screw. Refer to the computer Installation and Setup manual for instructions on reinstalling the computer cover.

**C•3 SUN-4 to MPC821ADS Interface**

The ADI board should be installed in one of the SBus expansion slots in the Sun-4 SPARCstation computer. A single ADI can control up to eight MPC821ADS boards.

**Support Information**

**CAUTION**

BEFORE REMOVING OR INSTALLING ANY EQUIPMENT IN THE SUN-4 COMPUTER, TURN THE POWER OFF AND REMOVE THE POWER CORD.

**C•3•1 ADI Installation in the SUN-4**

There are no jumper options on the ADI board for the Sun-4 computer. The ADI board can be inserted into any available SBus expansion slot on the motherboard.

Refer to the appropriate Installation and Setup manual for the Sun-4 computer for instructions on removing the computer cover and installing the board in an expansion slot.

**FIGURE A-3 ADI board for SBus**



Following is a summary of the Instructions in the Sun manual:

1. Turn off power to the system, but keep the power cord plugged in. Be sure to save all open files and then the following steps should shut down your system:
  - hostname% /bin/su
  - Password: mypasswd
  - hostname# /usr/etc/halt
  - wait for the following messages.  
Syncing file systems... done  
Halted  
Program Terminated  
Type b(boot), c(continue), n(new command mode)
  - When these messages appear, you can safely turn off the power to the system unit.
2. Open the system unit. Be sure to attach a grounding strap to your wrist and to the metal casing of the power supply. Follow the instructions supplied with your system to gain access to the SBus slots.
3. Remove the SBus slot filler panel for the desired slot from the inner surface of the back panel of the system unit. Note that the ADI board is a slave only board and thus will function in any available SBus slot.
4. Slide the ADI board at an angle into the back panel of the system unit. Make sure that the mounting plate on the ADI board hooks into the holes on the back panel of the system unit.



**Support Information**

5. Push the ADI board against the back panel and align the connector with its mate and gently press the corners of the board to seat the connector firmly.
6. Close the system unit.
7. Connect the 37 pin interface flat cable to the ADI board and secure.
8. Turn power on to the system unit and check for proper operation.

ARCHIVED BY FREESCALE SEMICONDUCTOR, INC.