

USER MANUAL and PARTS LIST
Multi-Mover S
Type S15
500W 24V



Version 0.1 Januari 2015

Multi-Mover Europe B.V.
www.multi-mover.eu
T +31 24 744 00 70 F +31 24 890 17 90
T+49 2841 999 8083



Transport

- * Only use stable loading surfaces with sufficient loading capacity (see section 2.2).
- * Secure the MULTI-MOVER S against tilting or sliding.
- * It is prohibited to;
 - get under the MULTI-MOVER S while lifting
 - remain within the tilting range of the MULTI-MOVER S during unloading

Contents

Chapter 1	INTRODUCTION / WARRANTY / DEFINITIONS / SAFETY SYMBOLS	3
Chapter 2	TECHNICAL DESCRIPTION	4
2.1	Designation, identification and description	4
2.2	Technical information and dimensions	4
2.3	Packaging, loading / unloading, towing, recycling	4
Chapter 3	SAFETY REGULATIONS	5
Chapter 4	PREPARATION	7
4.1	Application	7
4.2	Operator	8
4.3	Responsibility operator	8
4.4	Inspection prior to putting into operation	8
Chapter 5	USE	9
5.1	General	9
5.2	Regulations for use	9
5.3	Operation	10
5.4	Batteries	11
5.5	Coupling trailer(s)	13
Chapter 6	MAINTENANCE	13
6.1	Inspection	13
6.2	Lubrication and maintenance diagram	13
6.4	Cleaning	14
6.5	Taking out of operation	14
6.6	Annual maintenance	14
Chapter 7	ENVIRONMENT	14
Chapter 8	FAILURES	15
Chapter 9	PARTS	15
Chapter 10	DECLARATION OF CONFORMITY	16
Appendix I	Electrical circuit diagram	
Appendix II	User manual battery charger	

Multi-Mover Europe B.V.
 www.multi-mover.eu
 T +31 24 744 00 70 F +31 24 890 17 90



1 INTRODUCTION / WARRANTY / DEFINITIONS / SAFETY SYMBOLS

You have made the right decision, by purchasing the Multi-Mover S.
You are now in the possession of an excellent tool that has been constructed and produced with the greatest care.

You will profit the most from this investment, if you carefully observe the safety, user and maintenance instructions provided in this user manual.

The user manual should be made available to the user of the Multi-Mover S and must be present at the Multi-Mover S when it is being used. The user manual must have been read by anyone working with/at the Multi-Mover S, and the instructions must be observed.

Warranty

Multi-Mover Europe BV will not assume responsibility for the goods it produced and the services it supplied. Warranty can only be claimed if the client has made an immediate complaint and Multi-Mover Europe BV has been given the opportunity to investigate the complaints and correct possible faults. Multi-Mover Europe BV provides a warranty on its products in relation to materials and construction defects. In case of defects as described above, Multi-Mover Europe BV shall undertake to provide the parts manufactured by them for free, within the period of one year after delivery.

To occasions, different warranty conditions apply. Multi-Mover Europe BV will not be liable for damage and indirect damage as a result of natural disasters, operational errors, lack of skilful maintenance and any other use than described below.

The liability of Multi-Mover Europe BV will also terminate as soon as you or a third party performs work, such as adaptations or extensions, to the machine, without our written permission.

The warranty conditions only apply if a defect, after investigation by the manufacturer, is recognized as such.

At Multi-Mover Europe BV we continuously try to improve our products and service. That is why we reserve the right to change the specifications stated in this user manual at any required moment and without prior notice.

Definitions

In this user manual we use the following definitions:

Operator:	The person who drives, controls and supervises the operation of the Multi-Mover S and is able to start and stop it, etc. It is the company's responsibility to make sure that the operator is sufficiently trained.
Dangerous areas:	The area surrounding the Multi-Mover S where people may get injured.
Maintenance mechanic:	The person who is completely familiar with the Multi-Mover S, is able to adjust the safety devices and to maintain the Multi-Mover S. The maintenance mechanic is familiar with the functionalities, safety standards and was trained to maintain the Multi-Mover S. It is the company's responsibility to make sure that maintenance staff has been sufficiently educated and trained.

Safety symbols

On various places on the Multi-Mover S you will find standardized safety symbol stickers as displayed to the right.

The upper part warns against a general or particular hazard.

The lower part indicates what type of hazard is being warned against and will explain what you must do.



2 TECHNICAL DESCRIPTION

2.1 Designation, identification and description

Designation : MULTI-MOVER S
 Identification : type plate on the encasing
 Description : vehicle on two drive wheels and a swivel wheel
 : suitable as towing device, optionally provided with an upward and downward moving coupling point, for instance, in order to couple the pole of a trailer and possibly to lift it.
 : drive while walking, by using the driving switches on the steering handle

Accessories

The following parts are delivered separately with the vehicle:

The vehicle's operation manual
 Acid weighing unit (optional)
 Load report booklet (optional)
 Manuals for possible options

2.2 Technical information and dimensions (see type plate on Multi-Mover)

Maximum traction load	kg	1500
Maximum traction force	kg	150
Length x width x height	mm	590 x 480 x 1140
Weight, batteries excl.	kg	140
Speed, empty	km/h	0 - 5
Maximum slope angle, with / without load	%	10 / 20
Wheels, driven, standard	-	4 x 10.00 cm Full Rubber SC10 Continental
Swivel solid	-	80 mm
Brake, hand electromagnetic	-	Electric magnet brake release (page 11)
Motor	W	500 / 24Volt
Battery	Amps/hour	70/20h
l x w x h	mm	278 x 174 x 170 22kg
Battery charger, min. stop)	Amps	24V/ 8A(internal trickle charger + automatic stop)

2.3 Packaging, loading / unloading, towing, recycling

Packaging

The Multi-Mover S is secured with straps on support beams on a pallet, surrounded by a protective cardboard box.

Removing the packaging

Remove the clamping strips at the wheels.

Avoid injury and damage as a result of incorrect placement of the lift truck's lift forks.

Loading and unloading

If the Multi-Mover S has to be moved by means of a lift truck, the lift forks must be placed at the heaviest part at the rear of the Multi-Mover S, between the 2 large wheels.

Towing

Caution! Avoid serious damage to the drive, the Multi-Mover S may only be moved or towed if the hand brake tie rod (round black button) on the dashboard has been pulled out.

Recycling of the packaging

Save the packaging for possible future transportations.

If you want to remove the packaging, you must observe the local and national regulations concerning plastic waste processing.

3 SAFETY REGULATIONS.

Only use the Multi-Mover S for the purpose for which it was designed.

The symbols displayed below have been attached to your Multi-Mover S.

Get to know these symbols and make sure you know what they mean.

Caution! Hazard of serious injury.

Carefully read the user manual of the Multi-Mover S, so you will know exactly how to use the switches before you start driving it.



3.2

Caution! Hazard of injury during maintenance work.

Switch off the ignition and remove the ignition key, disconnect the charging plug and press the emergency stop.

Consult the user manual.

You will prevent dangerous situations that might arise if the Multi-Mover S starts to move unexpectedly.

Also consider the possibility that the vehicle is switched on by a third party, a coincidence or misunderstanding that could occur if the ignition key is still in the ignition.



3.3

Caution! Hazard of serious injury due to getting jammed or a collision.

Make sure that nobody can get jammed, also not at the trailer(s) that are being towed.

Particularly when riding along on the Multi-Mover S or the trailer(s) to be towed, there will be a risk of getting jammed or having a collision.

3.4

Caution! Hazard of serious injury on slopes due to tipping over.

The Multi-Mover S was constructed for driving on flat, dry, metalled and sufficiently supportive terrain.

The maximum slope angle that can be driven on, strongly depends on;

- the weight to be towed
- the driving style of the operator
- driving circumstances, and the strength of the terrain.

Caution! Hazard of serious injury due to unwanted movements on slopes as result of insufficient traction force and brake force of the Multi-Mover S.

Never drive onto a slope at an angle or crosswise.

Only ever drive on and off a slope at a right angle.

The Multi-Mover S with trailer(s) may also tip over if the bends are taken at a speed that is too high.



3.5

As the trailers may limit the operator's view and because the Multi-Mover S and trailer(s) may swerve out, there will be a risk of collision, therefore:

Caution! Hazard of (serious) injury due to collisions.

Make sure that bystanders remain at least 10 metres outside of the driving area of the Multi-Mover S and trailer(s).



3.6

Caution! Hazard of (serious) injury due to getting jammed or as a result of falling under the Multi-Mover S or trailer(s).

Passengers may "never" drive along on the Multi-Mover S or the trailers.

3.7

Caution! Hazard of serious injury.

Adapt your speed to the circumstances while driving.

Always make sure you have the Multi-Mover S under control.

- Reduce speed on uneven floors/terrain and in sharp bends.
- Be particularly careful when manoeuvring and reversing.

3.8

Caution! Hazard of injury due to getting jammed when connecting and disconnecting the trailer(s).

Keep your hands and fingers away from the coupling or pole eye.

3.9

Caution! Hazard of serious injury.

Before you start driving, make sure the walking/driving area is free and flat.

Avoid getting jammed between the Multi-Mover S and obstacles.

Prevent tripping and getting jammed under the Multi-Mover S and/or trailer.

Make sure the driving area and your shoes are free of dirt, in order to prevent accidents due to slipping.

3.10

Caution! Hazard of serious injury due to overloading the Multi-Mover S.

The load behind the Multi-Mover S may not be more than indicated at section 2.2 technical data.

Make sure the trailer(s) has/have been loaded evenly and safely.

3.11

Caution!

Wear clothing that allows you to move freely and does not hinder your view on the Multi-Mover S plus trailer(s). Observe your company's safety regulations. Wear safety shoes



3.12

Caution! Hazard of injury. In case of an unusual noise;

Stop the Multi-Mover S immediately.

Check the electric system and the drive for damage.

Check the wheels and tyres for tension, damage and wear.

3.13

Caution! Avoid injury.

Regularly check whether there are any loose bolts and nuts.

Also see chapter 6 (Maintenance).

3.14

Caution! Avoid injury by checking the Multi-Mover S for damage or bends on a daily basis.

Pay particular attention to the tow eye with tow pin or coupling point and locking.

3.15

Caution! Hazard of injury.

Make sure the Multi-Mover S is properly and safely supported when performing cleaning or maintenance work "under" the Multi-Mover S.

3.16

Caution! Hazard while charging the battery.

Make sure there is assistance within the range of your voice and also make sure there is sufficient soap and water nearby if you need to perform work near the battery.

Avoid short-circuit (sparks), make sure you do not make an electrical connection between the battery poles. Make sure no metal objects can fall on the battery, as this could cause a short-circuit or a spark and an explosion.

Remove personal objects such as rings, bracelets, necklaces and watches if you are performing work near the battery. A short-circuit, for example, could melt a ring, resulting in serious burns.

3.17

Caution! Hazard of injury due to overheating of the electrical connection of the battery charger.

Pay particular attention to cable diameter, earth and fuses.

3.18

Caution!

Serious injury can be received or caused if the Multi-Mover S is operated by;

- persons younger than 16 years of age
- persons who do not have any training and driving experience with the Multi-Mover S
- persons of whom it can be expected that they are not (sufficiently) aware of the dangers of the Multi-Mover S, temporary personnel for instance.

The MULTI-MOVER S may only be operated after the operator has thoroughly studied the user manual and after the owner of the Multi-Mover S has provided a full training / instruction concerning the operation and the safety regulations.

3.19

Caution! Hazard of serious injury.

Serious injury may be received or caused if the safety instructions are not provided to other operators.

3.20

Caution! You are NOT allowed to use the public road with the Multi-Mover S.

3.21

Caution!

Hazard of injury if the safety symbols are not clearly visible (any more).

Immediately replace damaged stickers.

3.22

Caution! Hazard of injury.

- maintenance and repair work may only be performed by a maintenance mechanic who is recognized by Multi-Mover Europe BV.
- only original Multi-Mover Europe BV or CE certified parts may be used in the Multi-Mover S.

3.23

As the operator you will determine the limits for "safe driving / working" with the Multi-Mover S. Do not take any risks.

Be particularly careful in case of obstacles or uneven terrain.

4 PREPARATION

4.1 Application

The Multi-Mover S was developed for;

- moving trailers, caravans, trailers with or without goods, order picking, etc.
- driving over flat, dry, metalled or unmetalled terrain (e.g. warehouse, greenhouse, lawns etc.)

The Multi-Mover S is **not** suitable for transporting trailers with people.

The Multi-Mover S is **not** suitable for moving;

- goods containing toxic substances
- goods containing explosive substances
- goods containing hazardous substances
- combustible substances
- other liquids and hazardous substances than stated above

The Multi-Mover S does **not** have permission to be driven on public roads.

Only use the Multi-Mover S for the purpose for which it was designed.

For other applications, the CE mark does not apply.

The electric components and wiring have been made drip-proof. Therefore, the Multi-Mover S may not be used in the rain, and must be covered in case of sprinkling or spraying plants. The Multi-Mover S must also be stored on a dry location.

Only the following "original" "Multi-Mover Europe BV" parts and accessories may be used for the Multi-Mover S.

Multi-Mover Europe BV is excluded from any liability for damages or consequential damages that are caused by "original" parts that have not been supplied by us.

4.2 Operator

Only persons who have had a thorough (internal) theoretical and practical training for driving the Multi-Mover S, are allowed to drive with the Multi-Mover S.

The training programme should cover:

- the application possibilities and the limitations
- the control and operating components
- the safety regulations
- daily and periodical maintenance

The operator must be fully familiar with the content of this user manual.

People could receive or cause serious injury, if the Multi-Mover S is operated by;

- **unauthorized persons**
- **persons younger than 16 years of age**
- **persons of whom it may be expected that they are not (sufficiently) aware of the dangers of the Multi-Mover S**

4.3 Responsibility of the operator

Operators must strictly observe the safety regulations, which are included in chapter 3, and the same applies to the other rules of conduct elsewhere in this user manual.

4.4 Inspection prior to putting into operation

In addition to good maintenance, the operator of the Multi-Mover S must pay attention to the following aspects after each work period.

- check whether there is any damage on the outside of the vehicle
- check the tow eye and tow pin or coupling point for bends or damage
- check whether the batteries are sufficiently charged
- drive forward and backward and check the operation of the brake.
- check, while driving slowly, the full manoeuvrability of the Multi-Mover S
- check the jam safety on the steering handle by pressing the safety switch (2, fig. 2), the Multi-Mover S should not start in that case.

If you establish a fault, or if you have any doubts concerning the operation of the Multi-Mover S you must immediately report this to your supervisor or the maintenance personnel.

5 USE

5.1 General

Always keep an eye on bystanders, avoid collisions.

Keep as far to the right as possible and maintain distance.

Never overtake another vehicle driving in the same direction at crossings, in small passages or on other dangerous places

- Make sure you keep a good view on the path that you are driving, keep an eye on traffic and people and observe the safety regulations.
- Caution! Hazard of serious injury due to unwanted movements on slopes as result of insufficient traction force and brake force of the Multi-Mover S.
- **Never drive onto a slope or another obstacle at an angle or crosswise.**
- **Only ever drive on and off a slope at a right angle.**
- **The Multi-Mover S may also tip over if the bends are taken at a speed that is too high.**
Maximum slope angle, with / without load 4% / 12 %

Passengers may **not** be taken along with the Multi-Mover S and towed vehicle.

When leaving the Multi-Mover S, **always** remove the ignition keys.

(Let someone) check whether your Multi-Mover S is suitable (approved) for driving in your environment, you could think of an environment with fire hazard or explosion hazard.

While driving, the generation of sparks may prevent switching on / off.

The traction batteries are filled with hazardous electrolyte that could cause serious burns. However, the batteries are fully sealed and do not have to be refilled with distilled water.

In case of injury to people or damage to buildings, immediately contact your supervisor.

Never park at fire lanes, fire-extinguishers and stairwells.

5.2 Regulations for use

Observe the traffic regulations;

- in a normal traffic situation you will keep to the right
- maintain a safe distance, depending on your speed, you will maintain a safe speed so you are able to maintain in complete control of your vehicle and trailer(s)

Make sure you keep a good overview of the area where you are driving and observe the safety regulations.

At crossings and locations where there is no good view, lower your speed and (#) give a warning signal. Drive slowly on narrow lanes.

Avoid bends if necessary and be careful on small hills, thresholds, etc.

Reduce speed in case of sharp bends.

The Multi-Mover S may only be driven at speeds that allow you to stop in time, e.g. if an obstacle is standing in or entering the driving area.

Accelerating, stopping, steering, making turns should always be performed quietly, so that the stability of the trailers to be towed is not endangered.

Your conduct while driving must be polite and safe.

Always be careful when the vehicle is driving on a limited slope or on slippery grounds.

Placement in /on a lift

Never manoeuvre the Multi-Mover S in/on a lift without permission; drive it slowly, place the vehicle correctly in the centre of this space, switch off the vehicle with the ignition key. Make sure there are no people on the lift when the vehicle is driven onto it.

Only transport safe and stable loads.

Make sure the weight of the load to be moved lies within the capacity of the Multi-Mover S.
The maximum traction force is stated on the type plate.

Caution! Prevent serious damage to the drive, the Multi-Mover S may only be towed with the handbrake button (15) in the “free position” page 11 (switched off).

5.3 Operation (see photo, fig. 1)

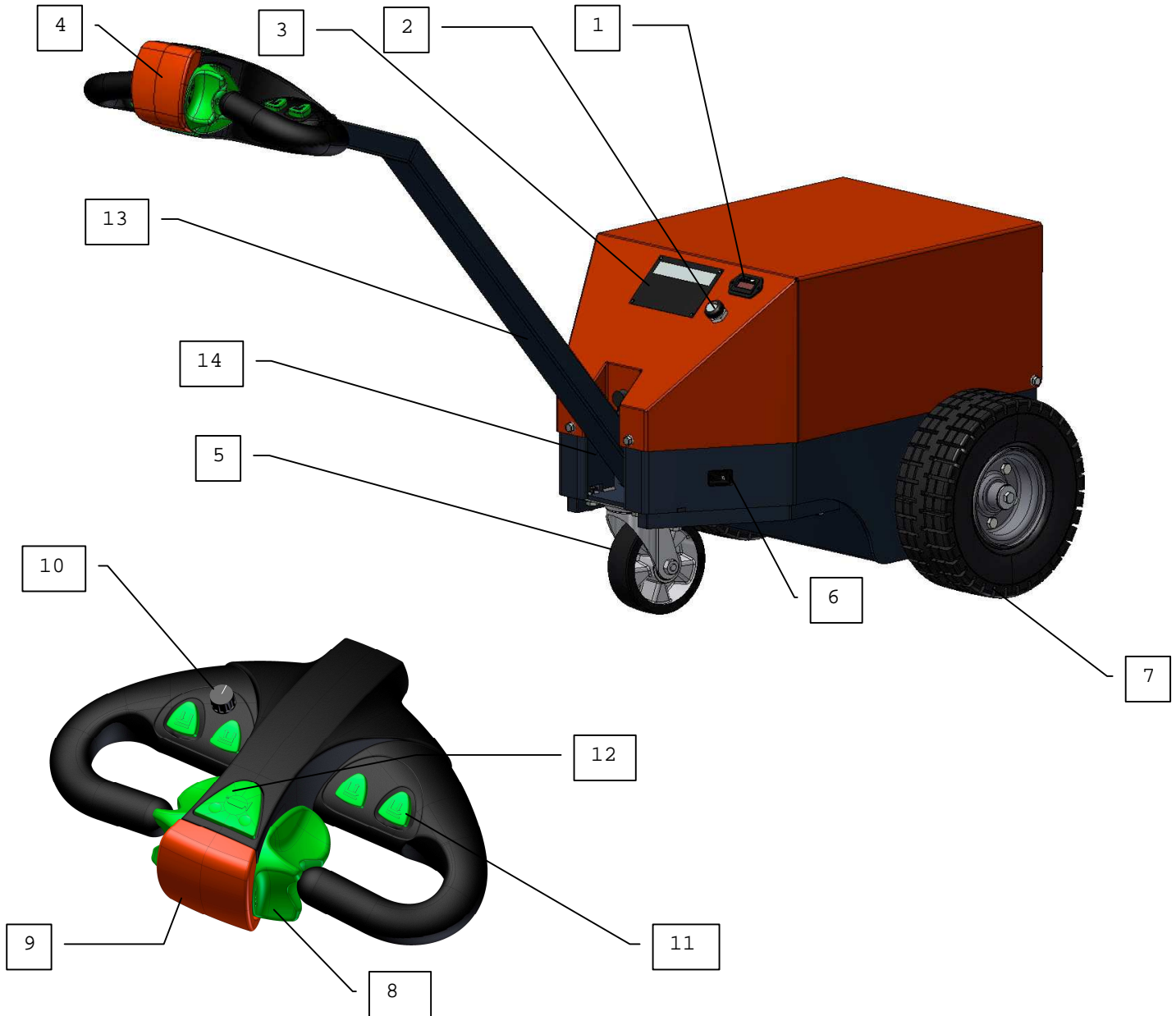

- | | | | |
|---|------------------------------|----|--|
| 1 | Battery indicator | 10 | Potentiometer maximum speed adjustment |
| 2 | Ignition lock | 11 | Option (up / down hitch) |
| 3 | Type plate | 12 | Horn |
| 4 | Steering handle (Tillerhead) | 13 | Steering bar |
| 5 | Swivel wheel | 14 | Hinge point steering bar |
| 6 | Charger cable plus | | |
| 7 | Wheel with solid tyre | | |
| 8 | Forwards/Backwards Throttle | | |
| 9 | Belly Button Emergency STOP | | |

Prior to putting the Multi-Mover S into operation, you must acquaint yourself with its possibilities. Read the instructions in advance and check the function of the control units with the ignition key in the OFF position.

Handbrake button 15

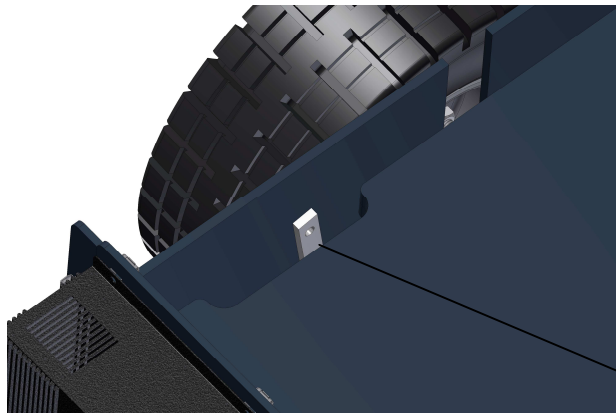

15 Electric magnet brake release

The wheels (7) are coupled to/disconnected from the motor by means of the handbrake button. If the handle is pulled down it is in the free position, the Multi-Mover S can now be freely manoeuvred by hand. If the button is pressed down, the Multi-Mover S can only be driven electrically.

COUPLER

Optionally (#), the coupling point (Hitch) can be moved approx. 20 cm upwards/downwards with an integrated actuator pushing (11).

Steering handles (4)

The steering handle (4) with bar is a fixed part of the Multi-Mover S, moving to the left means driving to the left, and vice versa.

Safety switch (9)

When pressing the safety switch (risk of getting jammed), the Multi-Mover S will stop immediately. In order to start again, the drive switch must first be placed in the neutral position.

Coupling point upward (11), # coupling point downward

Optionally, the coupling point can be moved upward/downward with an actuator (spindle motor). This serves, for instance, to make it easier to move a tandem axle trailer.

Signal switch (12) only upon request

Optionally, a horn can be connected to the signal switch (12).

Drive switches (8), left and right from the centre

By rotating the drive switch (8) to the front with your thumb, the driving direction will first be switched on and then, when rotated further, the Multi-Mover S will start to drive. The central position is the neutral position.

By rotating it downwards, the Multi-Mover S will reverse.

Caution! Only switch to forward or reverse if the Multi-Mover S is standing still.

Ignition lock (2)

The ignition lock (2 fig. 1) is used to switch off the batteries, **always switch off the battery in case of maintenance to the Multi-Mover S.**

5.4 Batteries

The batteries are filled with lead acid and sealed. They are fully sealed and maintenance free. It is not necessary possible to refill with distilled water.

Battery charger connection

The connection plug for the battery charger is located on the right side, in a recess of the encasing. On the dashboard of the Multi-Mover S, the battery indicator (1) is placed.

Red = charge immediately

Yellow = charge soon

Green = battery is full

For a longer life span, it is better not to allow the battery to get completely empty. It is also not good to continue charging a battery that is almost full.

If the Multi-Mover S is out of operation (for a longer period), we recommend keeping the battery charger connected, it will automatically keep the battery in a charged condition.

Charging location

The charging location must be well ventilated, because very explosive gases (detonating gas) are continuously released during charging.

Avoid open fire or sparks at the charging location while charging. During charging, an explosive gas may be released.

The battery charger (# optional) operates fully automatically, i.e. the charger is equipped with an electronic system that will check the charging status and act accordingly.

Check whether the supply voltage to the battery charger corresponds with the voltage stated on the battery charger.

Some instructions for battery use and maintenance.

Charging

This Model has an internal Charger

1 Insert the plug of the battery charger into the connection (6) on the encasing.

2 In the second phase, the automatic battery charger will charge all elements at maximum voltage in the final phase the battery charger will stop.

The battery charger will switch off automatically.

Premature wear of the battery

If the batteries are used incorrectly, it is possible that they wear quickly. Premature wear is not an error in production and is therefore not within the scope of the warranty arrangement.

Therefore, we would like to draw your attention to the following:

Excessive load of the battery

If the batteries are loaded excessively, this will strongly reduce the life span. This means that you will have to adapt the load.

Discharging too deeply

We recommend not to discharge the batteries completely. If this happens often, it will also result in premature wear. Keep a close eye on the battery indicator, connect the battery charger in time.

Adapted charger.

The batteries should be charged during a specific period. If the charging current is too low, or if the duration of the charging process is too short, the batteries will not be fully charged and the capacity of the batteries will be too low for your application, resulting in premature wear. If the charging current is too high, or if the duration of the charging process is too long, the battery can be overcharged. As a result, the plates of your battery will overheat and may become damaged.

Intermediate charging

If, for example, the batteries are empty for only 60% and are reconnected to the charger, the batteries will not get the time to relax. The temperature of the batteries will increase, resulting in premature wear. Also, the voltage of the battery will become higher than the actual energy condition, which means that the discharge limiter will no longer work correctly.

Ambient temperature

The temperature of the battery may not get too high, as the acid will become more aggressive. Here, we are thinking of greenhouses and other heated spaces.

Frequent use

If, every 7 days, the batteries are used on more than 3 days, they will also wear more quickly. When selecting batteries, it is important to take into account the Multi-Mover S's frequency of use.

Sulphation

A battery will slowly discharge as a result of automatic discharge. If a battery remains in a discharged condition, it will start to sulphate and become damaged beyond repair. We therefore recommend recharging the stored Multi-Mover S every 2 months.

It is also possible, that there are still standby consumers in a switched off Multi-Mover S (key ignition etc.), which will mean that the batteries will discharge more quickly.

In that case, regular recharging of the batteries is recommended.

Immediate recharging of an empty battery, significantly promotes a longer life span. Further discharging than 20% has a negative effect on the life span.

The gases that are released while charging the battery are highly explosive (detonating gas).

Therefore, avoid fire and sparks near the charging location.

Charging may only take place in a well ventilated room.

Regularly check whether the battery charger stops automatically when the battery is full.

Never interrupt the charging process, make sure it is fully completed.

While charging the battery, **never** perform repair, cleaning or other work to the Multi-Mover S.

Prior to disassembling the batteries, switch off all power consumers, because of the generation of sparks.

When disassembling the batteries, first disconnect the mass cable (-)

When assembling, connect the mass cable as last.

Caution! Always plus (+ = red) to plus and minus (- = black) to minus

Battery fluid is a corrosive acid, avoid contact with clothing, skin and eyes.

Immediately wash off possible splashes on clothes or skin with water and soap, then rinse off with plenty of water. Possible splashes of acid in the eyes, rinse with clean water for at least 5 minutes and immediately consult a doctor.

When the battery is replaced, the old battery should be returned to your dealer or handed in at a legally recognized collection point for batteries.

5.5 Coupling trailer(s)

Maximum slope angle, with / without load 10 / 20 %

Slowly reverse the Multi-Mover S to the pole of the trailer and place the tow eye or coupling of the pole between the tow eyes, hitch or coupling point of the Multi-Mover S and insert the tow pin. Then secure the tow pin with a spring clip.

Only use the Multi-Mover S if you have thoroughly studied the previous pages and you have no more questions.

6 MAINTENANCE

When performing maintenance, you should always observe the safety regulations, (chapter 3).

During maintenance, always switch off the Multi-Mover S and remove the ignition key from the ignition lock

In case of doubt, consult the user manual.

6.1 Inspection

The operator should perform the following inspections regularly, without trailer;

- it must be possible to rotate the steering handle (swivel wheel) smoothly to the left and right, without jolts
- keep an eye on the wear of driven (air) tyres, if the wheels slip in case of sudden brakes, they will have to be replaced
- when accelerating quietly, it must be possible to reach the maximum speed

If one of the above tests is not satisfactory, you must immediately report this to person who is directly responsible for the maintenance of the Multi-Mover S.

6.2 Lubrication and maintenance diagram

d = daily w = weekly m = monthly a = annually

m = maintenance r = replacement

= only by qualified, trained, specialists

	m / r	d / w / m / a
1 inspection / cleaning bottom side Multi-Mover S	-	d
2 inspection battery charge, depending on intensity of use	-	d
3 inspection wear drive wheels	-	w
4 cleaning carbon brushes electric motor, minimum	#	a
5 replacing carbon brushes if less than 1 cm. long	#	-
6 lubricating nipples on bearings drive and swivel wheels	v#	a

6.4 Cleaning

When used inside and outside, the bottom will become dirty with particles from the surroundings. It is necessary to remove this dirt regularly, as contamination could hinder the operation of the drive.

Do not use a high-pressure cleaner or a hard water jet for cleaning, as the electric and electronic system is not water-tight and could be damaged.

6.5 Taking out of operation

If the Multi-Mover S is not used for a certain period, you will have to;

- connect the battery charger
- place the Multi-Mover S on blocks, so that the tyres do not touch the ground

Have maintenance and repairs performed by persons authorized by Multi-Mover Europe BV.

In case of doubt, always consult your supplier.

For the above-mentioned maintenance instructions, we assumed normal use.

In case of intensive use, or use under extreme conditions, maintenance will have to be performed with shorter intervals.

6.6 Annual maintenance. ***

See 6.2 +

Check whether all bolts are still tight and check the rotation/hinge points and guides for wear and play, replace or overhaul if necessary.

Check the carbon brushes for wear and have them replaced if necessary.

***** = only by qualified, trained specialists**

7 ENVIRONMENT

7.1 General

Residues of lubrication oil, oil-stained cloths, batteries and possible cleaning agents must be disposed of separately as chemical waste.

7.2 Consequences for the environment

Life span

The expected life span of the Multi-Mover S depend on maintenance, operating hours and ambient conditions (dust, contamination, humidity etc.).

Good maintenance will be beneficial to the life span.

Disposal

Preferably, you should have the disposal and processing performed by a recognized dismantlement or demolition contractor who has the necessary permits.

Appoint a competent responsible person to supervise its execution.

Sort disassembled materials according to material characteristics and contamination.

Separate all materials that fall under the category of chemical waste, such as oil, lubricants, switching material, batteries and certain electric components. Dispose them as chemical waste.

Offer residual materials to recognized waste processing companies who have the required permits.

8 FAILURES

When removing a failure, ALWAYS switch off the Multi-Mover S and remove the ignition key. If a defect is established at the Multi-Mover S, do not use it until the repair has been completed.

Failure	Solution
A The Multi-Mover S does not drive.	
1 Battery empty	1 Charge battery
2 Battery clamps make poor contact	2 Clean, attach again
3 Direction switch defective	3 Replace switch
4 Other causes.	4 Consult your dealer
5 Electric brake uncoupled	5 Press brake handle
B The Multi-Mover S functions occasionally.	
1 Loose wiring	1 Check wiring
2 Dirty or worn carbon brushes	2 Clean or replace if less than 1 cm. long
3 Dirty or worn collector motor	3 Clean, or have it overhauled, or replace it
4 Relay does not come "in" properly due to contamination or defect	4 Clean or replace
C Speed cannot be controlled (properly), or it drives at high speed immediately.	
1 Speed controller defective	1 Replace
2 Relay defective	2 Replace

In case of a failure not mentioned in the list above, please contact your dealer.

Note: In the warranty period, it is absolutely prohibited to perform repairs, changes and modifications or anything like that to the Multi-Mover S, the warranty will become invalid automatically.

9 PARTS

001	Battery (state amperage)	009	Swivel wheel
002	Drive motor	010	Axl for benefit of drive wheels
003	Carbon brush set	011	Battery plug
004	Relay	012	Female plug for battery plug
005	Speed switch	013	Fuses, set
006	Ignition lock	014	Main fuse
007	Reverse switch forward - reverse	020	Symbol stickers
008	Drive wheel		

EC DECLARATION OF CONFORMITY
(according to Appendix II A of the Machinery Directive)

IIA

We, Multi-Mover Europe BV,
Boomsestraat 38, 6613 AH Balgoij, Netherlands

declare at our own full responsibility, that the Multi-Mover S ***, with serial number 2015 ***

to which this declaration applies, is in conformity with the provisions of the following directive(s):

Applied directive :

2006/42/EC

and is in conformity with the following standard(s) or other standardizing document(s):

EN-ISO 12100	Safety of machinery -- General principles for design -- Risk assessment and risk reduction.
EN-ISO 14121-2	Safety of machinery -- Risk assessment -- Part 2: Practical guidance and examples of methods.
EN-ISO 13857	Safety of machinery -- Safety distances to prevent hazard zones being reached by upper and lower limbs.
EN-953	Safety of machinery - Guards - General requirements for the design and construction of fixed and movable guards
EN-82079-1	Preparation of instructions for use -- Structuring, content and presentation -- Part 1: General principles and detailed requirements
EN 60204-1	Safety of machinery - Electrical equipment of machines - Part 1: General requirements.
EN-IEC 60439-1	Low-voltage switchgear and controlgear assemblies – Part 1: Type-tested and partially type-tested assemblies.
EN ISO 3864-2	Graphical symbols -- Safety colours and safety signs -- Part 2: Design principles for product safety labels

Authorized compiler of the technical file :

Netherlands, Balgoij, 1.1.2015

HJ van Haren

(Country, city and date of issue)

(Name and signature or equivalent authentication by authorized person)