

Manual

Elinx EIRHP305-T

5 Ports 10/100 with 4 PoE Ports
Unmanaged Din Rail Ethernet Switch



EIRHP305-T

Documentation Number: EIRHP305-T-2011m



International Headquarters:

707 Dayton Road
Ottawa, IL 61350 USA

Phone (815) 433-5100

Website: www.bb-elec.com

Sales e-mail: orders@bb-elec.com

Technical Support: support@bb.elec.com –

European Headquarters

B&B Electronics

Westlink Commercial Park

Oranmore, Co. Galway, Ireland

Phone +353 91-792444

Website: www.bb-europe.com

Sales e-mail: sales@bb-europe.com

Technical Support: support@bb-europe.com

Original – April 2011

©2011 No part of this publication may be reproduced or transmitted in any form or by any means, electronic or mechanical, including photography, recording, or any information storage and retrieval system without written consent. Information in this manual is subject to change without notice, and does not represent a commitment on the part.

B&B Electronics Manufacturing shall not be liable for incidental or consequential damages resulting from the furnishing, performance, or use of this manual. All brand names used in this manual are the registered trademarks of their respective owners. The use of trademarks or other designations in this publication is for reference purposes only and does not constitute an endorsement by the trademark holder.

Table of Contents

OVERVIEW	1
Features.....	1
HARDWARE DESCRIPTION	3
Dimensions	3
Front Panel	4
Top View	4
LED Indicators	5
RJ45.....	6
Cabling	8
Wiring the Power Inputs	8
MOUNTING INSTALLATION.....	9
DIN-Rail Mounting	9
Hanging the Industrial Switch	10
Wall-Mount Plate Mounting	11
Hardware Installation Diagram.....	12
Troubleshooting.....	13
Technical Specification	14

Overview

B&B Electronics PoE Ethernet switch, 5 port 10/100TX with 4 offering High-Power (25W) PoE ports. The Industrial Switch is a cost-effective solution which meets the high reliability requirements demanded by industrial applications. The Ethernet switch supports wide temperature - 40°C - 75°C environments. The PoE feature meets IEEE 802.3af pre-standard, which supports 25 watts @ 48VDC on each PoE port.

Features

- System Interface/Performance
 - RJ-45 ports support Auto MDI/MDI-X Function
 - Embedded 4-ports PoE
 - Store-and-Forward Switching Architecture
 - Back-plane (Switching Fabric): 1.0Gbps
 - 2K MAC Address Table
- Power Input
 - DC 48V Redundant Power Input
- Operating Temperature
 - Wide Operating Temp: -40°C -75°C
- Case/Installation
 - IP-30 Protection
 - Installation in a Pollution Degree 2 environment
 - DIN Rail and Wall Mount Design
- Provides EFT protection 3,000 VDC for power line
- Supports 6,000 VDC Ethernet ESD protection

Package Contents

- 5 port 10/100TX with 4 Port High-Power (25W) PoE Industrial Switch (with DIN-Rail Bracket)
- User manual
- Removable Terminal Block
- Wall-mount Kit (2 wall-mount bracket with screws)

Hardware Description

The following information is an introduction to the PoE Industrial Ethernet Switch dimensions, port, cabling information, and wiring installation.

Dimensions

5 port 10/100T(X) with 4 High-Power (25W) PoE ports Industrial Switch dimensions (W x D x H) is 48.60mm x 95mm x 140mm, the detail dimensions as **Figure-1**

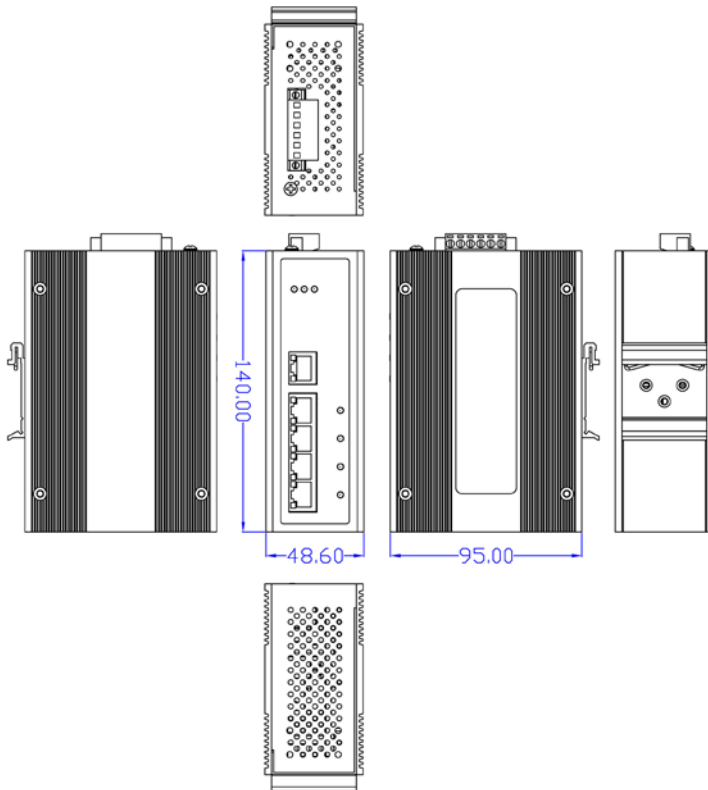

Figure-1: Mechanical Dimensions

Front Panel

The Front Panel of the 5 port 10/100TX with 4 Port High-Power (25W) PoE Industrial Switch is shown below **Figure-2**

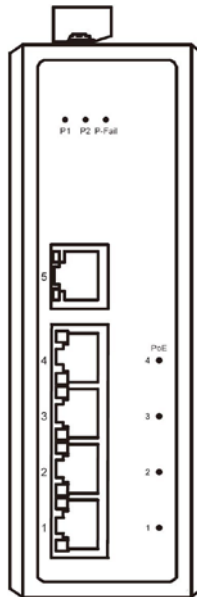

Figure-2: Front Panel of the Switch

Top View

The top view displays one terminal block connector, which allows wiring of two DC power inputs and a Relay circuit contact. Please refer to **Figure-3** for further information.

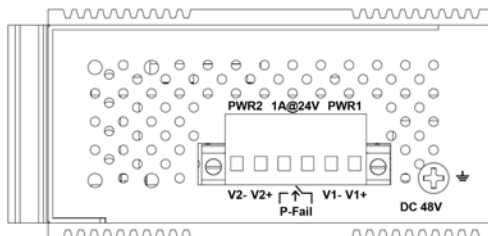

Figure-3: Top View of the Switch

LED Indicators

The diagnostic LEDs located on the front panel of the industrial switch provide real-time information of system and operation status. **Table-1** provides the description of the LEDs status and their definitions.

LED	Color	Description	
P1	Green	On	Power input 1 is active
		Off	Power input 1 is inactive
P2	Green	On	Power input 2 is active
		Off	Power input 2 is inactive
P-Fail	Red	On	Power input 1 or 2 has failed
		Off	Power input 1 and 2 are both functional, or no power inputs
PoE indicator (Port 1 ~ 4)	Green	On	The port is supplying power to the powered-device
		Off	No powered-device attached or power supplying fails
LAN Port 1 ~ 5 (RJ-45)	Green	On	Connected to network
		Flashing	Networking is active
		Off	Not connected to network
	Amber	On	Full-duplex link
		Flashing	Collision occurs
		Off	Half-duplex link or link down

Table-1: LED Indication Definition

RJ45

The RJ45 copper ports support auto MDI/MDIX operation. This feature allows network connections to computers, servers, or other switches using straight-through or crossover cables (See Figure below). Straight-through cable connections: pins 1, 2, 3 and 6, at one end of the cable, are connected straight-through to pins 1, 2, 3 and 6 at the other end of the cable. The table below shows the 10BASE-T/100BASE-TX MDI and MDI-X port pin outs.

Pin	MDI-X Signal Name	MDI Signal Name
1	Receive Data plus (RD+)	Transmit Data plus (TD+)
2	Receive Data minus (RD-)	Transmit Data minus (TD-)
3	Transmit Data plus (TD+)	Receive Data plus (RD+)
6	Transmit Data minus (TD-)	Receive Data minus (RD-)

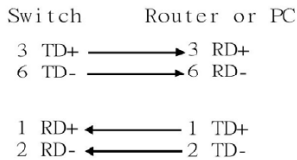

Straight Through Cable Schematic

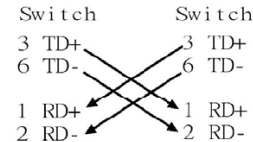

Cross Over Cable Schematic

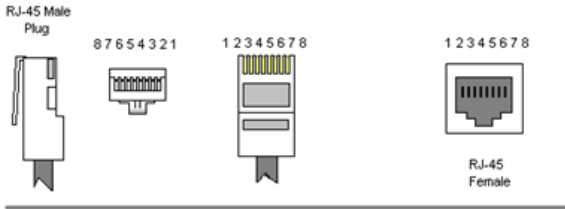

Color Standard EIA/TIA T568A Ethernet Patch Cable



Color Standard EIA/TIA T568A Ethernet Crossover Cable

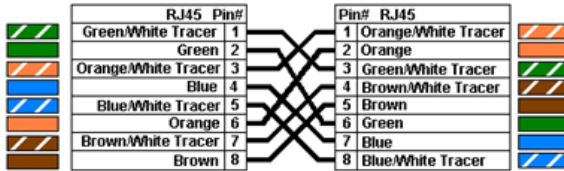

"A" is earlier

2006.06.28

Color Standard EIA/TIA T568B Ethernet Patch Cable

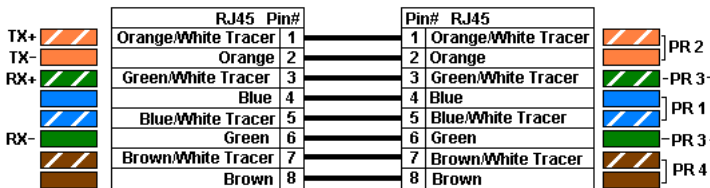

Color Standard EIA/TIA T568B Ethernet Crossover Cable

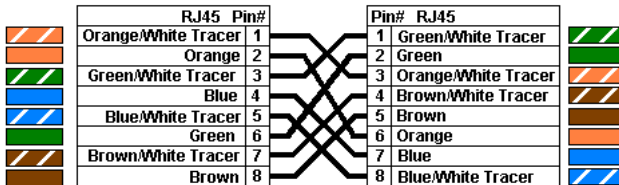

"B" is most recent

Common Ethernet Crossover Cables may only cross connect the Orange & Green pairs

2006.06.28

Cabling

Use unshielded twisted-pair (UTP) or shielded twisted-pair (STP) cable for RJ-45 connections: 100 Ω Category 3, 4 or 5 cable for 10Mbps connections, 100 Ω Category 5 cable for 100Mbps, or 100 Ω Category 5e/above cable for 1000Mbps connections.

The cable between the switch and the link partner (switch, hub, workstation, etc.) must be less than 100 meters (328 ft.) long.

Wiring the Power Inputs

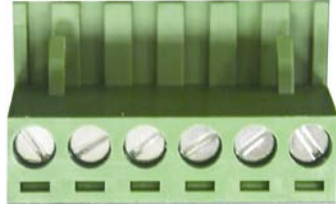

V- V+

V- V+

Note:

1. Terminal blocks are rated for 12-24 AWG wire
2. Use copper conductors, 60/75°C. Tighten to 5 lb in.

Mounting Installation

DIN-Rail Mounting

Assembling the DIN-Rail Clip

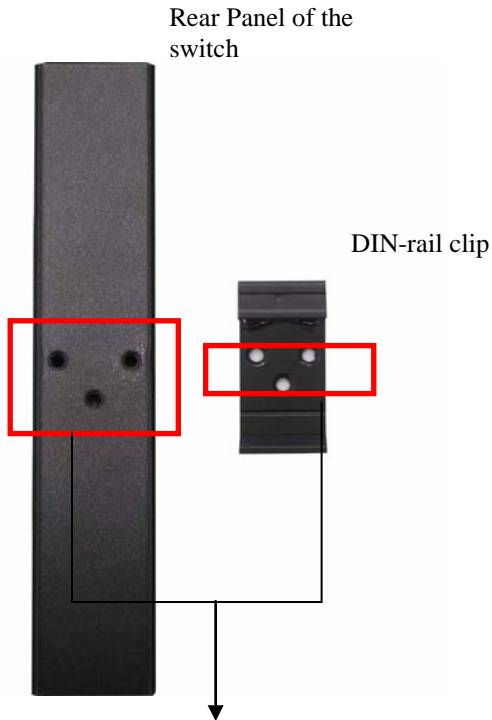

Hang the Industrial Switch

First, position the din-rail clip of the switch directly in front of the DIN rail. Make sure the top of the clip hooks over the top of the DIN rail.

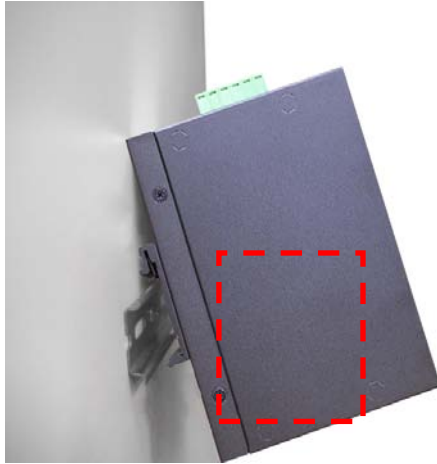

Push the unit downward.

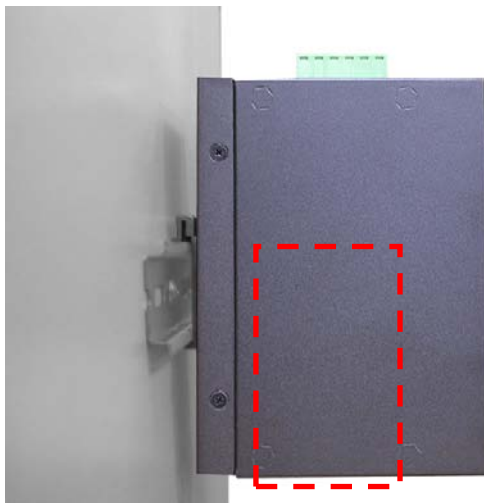

Check the DIN-Rail clip is tightly fixed on the DIN rail.
To remove the industrial switch from the track, reverse the steps above.

Wall-Mount Plate Mounting

1. When using the wall mount plates the din-rail clip can be removed.
2. Place the wall-mount plates on the rear panel of the industrial switch and fasten the screws.

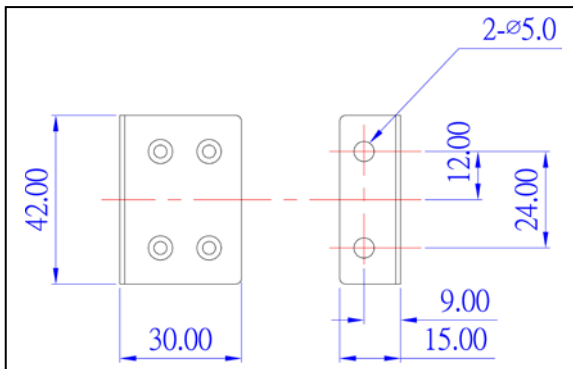
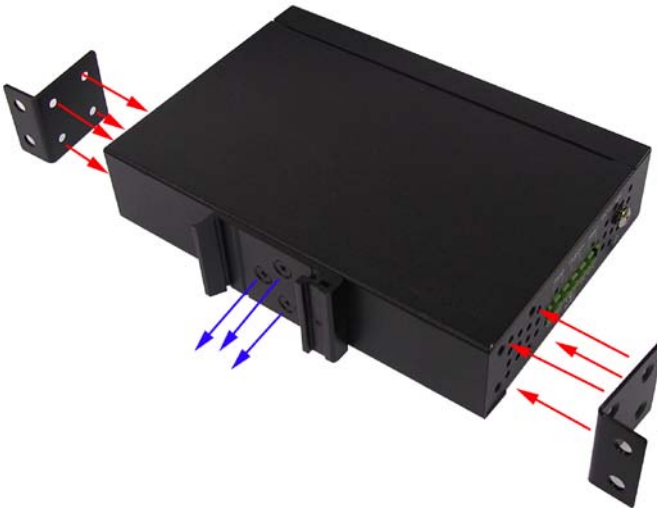

Wall-Mount Bracket Dimensions

Hardware Installation Diagram

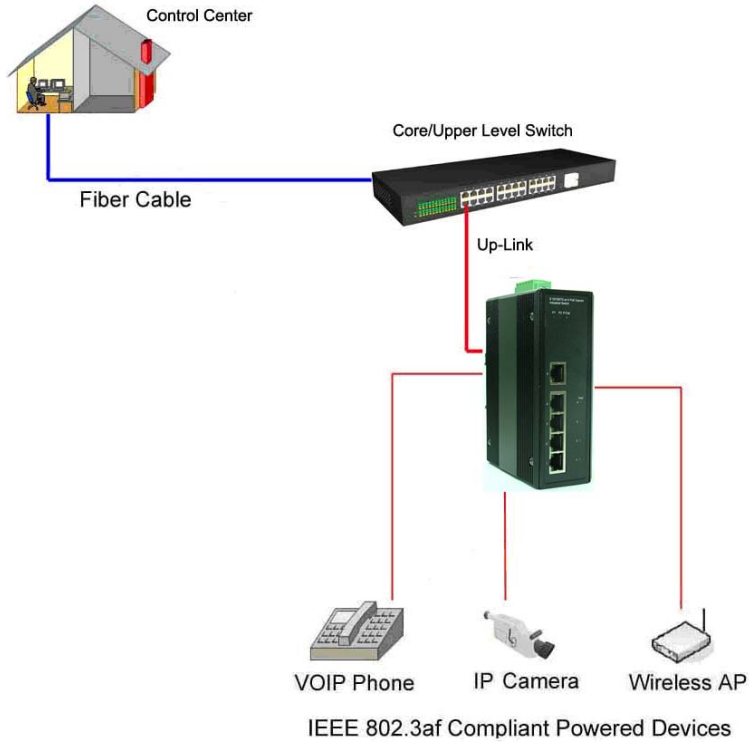

Troubleshooting

- Do not use the power adapter with DC output higher than the power rating of the device.
- Select the proper UTP/STP cable to construct your network. Use unshielded twisted-pair (UTP) or shielded twisted-pair (STP) cable for RJ-45 connections: 100 Ω Category 3, 4 or 5 cable for 10Mbps connections, 100 Ω Category 5 cable for 100Mbps, or 100 Ω Category 5e/above cable for 1000Mbps connections. Insure the length of any twisted-pair connection does not exceed 100 meters (328 feet).
- **Diagnosing LED Indicators:** The Switch can be easily monitored through panel LED's. The LED's will provide an easy way of detecting power or communication problems.
- During loss or no communications verify the Industrial switch LED indicators are displaying normal operating status. Next perform the ping test to confirm connection and status of device connections on the network.

Technical Specification

The 5 port 10/100TX with 4 port High-Power (25W) PoE Industrial Switch technical specifications is shown as below.

Standard	IEEE 802.3 10Base-T Ethernet IEEE 802.3u 100Base-TX Fast Ethernet IEEE802.3x Flow Control and Back Pressure IEEE802.3at Power over Ethernet
Protocol	CSMA/CD
Transfer Rate	14,880 pps for 10Base-T Ethernet port 148,800 pps for 100Base-TX Fast Ethernet port
MAC Address	2K MAC address table
Connector	10/100TX: 5 x RJ-45 Power, P-Fail: 1 x 6 poles Removable Terminal Block
PoE Pin Assignment	RJ-45 port #1 ~ # 4 support IEEE 802.3at End-point, Alternative A mode. Positive (VCC+): RJ-45 pin 1, 2. Negative (VCC-): RJ-45 pin 3, 6. Data (1,2,3,6)
LED	Per unit: Power 1 (Green), Power 2 (Green), P-Fail (Red) Per port: Link/Activity (Green), Full duplex/Collision (Amber) PoE: Feeding Power (Green)

Network Cable	10Base-T: 2-pair UTP/STP Cat. 3, 4, 5, 5e, 6 cable EIA/TIA-568 100-ohm (100m) 100Base-TX: 2-pair UTP/STP Cat. 5, 5e, 6 cable EIA/TIA-568 100-ohm (100m)
Over Current Protection	Fast-Blown Fuse
Power Supply	Redundant power DC 48V with connective removable terminal block
Max Power Consumption	110 Watts (@ 48V) Full load with PoE function
Installation	DIN-Rail mounting, Wall mounting
Operating Temp.	-40 to 75°C -40 to 65°C (non-air-flow environment)
Operating Humidity	5% to 95% (Non-condensing)
Storage Temp.	-40°C to 85°C
Case Dimension	IP-30, 48.6mm (W) x 95mm (D) x 140mm (H)
EMC	FCC Class A CE EN61000-4-2/3/4/5/6/8 CE EN61000-6-2 CE EN61000-6-4
Safety	cUL / UL 508
Stability testing	IEC60068-2-32 (Free fall) IEC60068-2-27 (Shock) IEC60068-2-6 (Vibration)