

PowerEdge T420



Technical Guide



The quiet, powerful, scalable PowerEdge T420 delivers performance, capacity and high availability features to drive your business or organization forward.



This document is for informational purposes only. Dell reserves the right to make changes without further notice to any products herein. The content provided is as is and without express or implied warranties of any kind.

Dell, the DELL logo, PowerEdge, EqualLogic, PowerVault, PowerConnect, OpenManage, KACE, and ReadyRails are trademarks of Dell, Inc. Intel and Xeon are registered trademarks of Intel Corporation in the U.S. and other countries. Microsoft, Windows, Windows Server, SQL Server, BitLocker, ActiveX, Internet Explorer, and Hyper-V are either registered trademarks or trademarks of Microsoft Corporation in the United States and/or other countries. SUSE is a registered trademark of Novell, Inc. in the United States and other countries. IBM, Tivoli, and Netcool are registered trademarks of IBM in the United States. Other trademarks and trade names may be used in this document to refer to either the entities claiming the marks and names or their products. Dell disclaims proprietary interest in the marks and names of others.

©Copyright 2012 Dell Inc. All rights reserved. Reproduction or translation of any part of this work beyond that permitted by U.S. copyright laws without the written permission of Dell Inc. is unlawful and strictly forbidden.

October 2012 | Version 2.0



Table of contents

1	System overview.....	5
	Introduction.....	5
	New technologies	6
2	System features	7
	Comparison of PowerEdge systems	7
	Specifications	8
3	Chassis views and features.....	11
	Chassis views.....	11
	Chassis features	14
4	Processor.....	17
	Processor features.....	17
	Supported processors.....	17
	GPU support.....	18
	Chipset.....	18
5	Memory.....	19
	Supported memory	19
	Memory configurations	20
	Memory speed	21
	Memory RAS features.....	21
6	Storage.....	23
	Internal storage	23
	External storage	23
	Storage controllers.....	24
	Optical drive	25
	Tape drive.....	25
7	Networking and PCIe	26
	Embedded NIC controller.....	26
	PCIe expansion	26
8	Power, thermal, and acoustics	28
	Power consumption and energy efficiency.....	28
	Power supply units	29
	Thermal and acoustics.....	30
9	Rack rails and cable management	33
	Sliding rails	33
	Cable management arm.....	34
10	Operating systems and virtualization	35
	Supported operating systems.....	35
	Supported virtualization	36
11	Dell OpenManage systems management.....	36
	Systems management solutions.....	37
	OpenManage systems management	38
	Dell server management operations.....	43
Appendix A.	Additional specifications.....	45
	Chassis dimensions and weight	45
	Power supply specifications	45
	Environmental specifications	46
	Video specifications	47
	Rack rail specifications	47
	USB peripherals.....	48
Appendix B.	Standards compliance	49



Appendix C.	Additional resources.....	50
Appendix D.	System board block diagram.....	52

Tables

Table 1.	New technologies.....	6
Table 2.	Comparing the PowerEdge T410 to PowerEdge T420.....	7
Table 3.	Technical specifications.....	8
Table 4.	Chassis configurations.....	11
Table 5.	Chassis features.....	14
Table 6.	Security features.....	16
Table 7.	Supported processors.....	18
Table 8.	Memory technologies supported.....	19
Table 9.	DIMMs supported.....	20
Table 10.	Memory speed capabilities.....	21
Table 11.	Memory RAS features.....	21
Table 12.	Supported hard drives.....	23
Table 13.	Supported RAID controllers.....	24
Table 14.	Supported external storage.....	25
Table 15.	Supported NICs and HBAs.....	26
Table 16.	Power tools and technologies.....	28
Table 17.	Power supply efficiency.....	30
Table 18.	Acoustical performance.....	32
Table 19.	Supported rack types.....	33
Table 20.	Primary operating system support.....	35
Table 21.	Virtualization support.....	36
Table 22.	iDRAC7 with Lifecycle Controller functions and benefits.....	38
Table 23.	Feature comparison for basic management, iDRAC7 Express, and iDRAC7 Enterprise.....	39
Table 24.	One-to-one and one-to-many operations.....	44
Table 25.	Power supply specifications.....	45
Table 26.	Environmental specifications.....	46
Table 27.	Supported video modes for back VGA port.....	47
Table 28.	Supported video modes for front VGA port.....	47
Table 29.	Rail adjustability range.....	48
Table 30.	Industry standard documents.....	49
Table 31.	Additional resources.....	50

Figures

Figure 1.	Front view 16-drive bay without bezel.....	11
Figure 2.	Front view with bezel.....	12
Figure 3.	Back view.....	12
Figure 4.	Internal view.....	13
Figure 5.	Rackable front view without bezel.....	13
Figure 6.	LCD control panel.....	15
Figure 7.	QRL location.....	15
Figure 8.	750W power supply unit.....	30
Figure 9.	Sliding rails with optional CMA.....	33
Figure 10.	Dell systems management solutions.....	37
Figure 11.	Systems management server lifecycle.....	43
Figure 12.	Tower and rack chassis dimensions.....	45
Figure 13.	T420 system board block diagram.....	52



1 System overview

Introduction

The 2-socket Dell™ PowerEdge™ T420 tower server delivers balanced performance and expandability for non-disruptive growth. Optional redundancy and hot pluggability of key components helps to protect data and keep the business running. The T420 is an excellent fit for a wide range of applications, including workgroup collaboration, email, file and print, and small- to mid-size database applications such as Business Analytics and Intelligence. In addition, the T420's performance and capacities make it highly attractive for consolidation and virtualization.

A versatile workhorse

Featuring the powerful performance of two Intel® Xeon® processors E5-2400 product family, and complemented by substantial memory capacity and broad I/O bandwidth, the T420 provides high, balanced performance and built-in room for growth. Its twelve DIMM slots and six PCIe slots provide memory density and wide I/O bandwidth to support both memory-intensive and data-intensive applications and databases. Built-in capacity for up to eight 3.5-inch or sixteen 2.5-inch hard drives accommodate data storage as your business or organization grows. These combined technology features are highly beneficial when implementing consolidated and virtualized environments, a role in which the T420 also shines.

To protect your virtualized workloads, the PowerEdge T420 offers dual SD media making your hypervisors redundant and failsafe. Other reliability and availability features include hot-plug hard drives, both hardware and software RAID options, redundant fans and hot-plug power supplies.

The PowerEdge server line

The PowerEdge family is engineered with the right combination of features and performance scalability to handle tough workloads for businesses and organizations of all sizes.

The Dell OpenManage™ systems management portfolio includes Integrated Dell Remote Access Controller 7 (iDRAC7) with Lifecycle Controller. This embedded feature helps IT administrators manage Dell servers in physical, virtual, local and remote environments, operating in-band or out-of-band, with or without a systems management software agent. Dell OpenManage solutions integrate with and connect to third-party systems management solutions so you can maintain your single point of control and capitalize on your existing investment. Dell OpenManage capabilities simplify IT administrator tasks and reduce potential for error throughout the server lifecycle, spanning deployment, updating, monitoring, and maintaining your Dell PowerEdge servers.



New technologies

Table 1 summarizes the newest technologies used in the Dell PowerEdge T420 tower server.

Table 1. New technologies

New technologies	Detailed descriptions
Intel Xeon processor E5-2400 product family	This new family of Intel processors has embedded PCIe lanes for improved I/O performance. See the Processor section for details.
Intel C600 series chipset	The Intel Platform Controller Hub (PCH) chip is implemented on the T420 server.
1600MT/s DDR3 memory	Certain models of the Intel Xeon processor E5-2400 product family support 1600MT/s memory. The T420 supports two DIMMs per channel at 1600MT/s with certain models. See the Memory section for details.
Next generation PERC options	The T420 supports the new PERC controller cards with improved functionality and faster performance. See the Storage section for details.
PERC S110 software RAID Solution	This new software RAID solution supports RAID 0, 1, 5 and 10, and supports a maximum of four hot-plug SATA hard drives or SATA solid-state drives. See the Storage section for details.
iDRAC7 with Lifecycle Controller	The new embedded system management solution for Dell servers features hardware and firmware inventory and alerting, in-depth memory alerting, faster performance, a dedicated gigabit port, and many more features. See the Dell OpenManage systems management section for details.
Internal GPU support	The T420 supports internal graphics processing units (GPUs) for virtual desktop infrastructure (VDI) and medical imaging. See the Processor section for details.
Advanced power management	The T420 supports advanced power monitoring and power capping tools that can help manage power consumption. See the Power, thermal, and acoustics section for details.
Fresh Air cooling	Dell has tested and validated an integrated data center solution that enables you to operate at higher temperatures or even chiller-less. See the Power, thermal, and acoustics section for details.
Failsafe hypervisors	The internal dual SD module enables Dell's unique failsafe virtualization architecture, ensuring uptime by providing failover capability for embedded hypervisors such as VMware® vSphere® ESXi™. See the Supported virtualization section for details.
Fan fault tolerance	Failure of one fan rotor is tolerated with degradation in performance through active throttling and increased fan speeds. This feature helps reduce downtime by allowing you to schedule a fan replacement within 360 hours of a fan failure.



2 System features

Compared to the previous generation PowerEdge T410, the T420 supports up to 33% more processor cores, 50% more DIMM slots, 166% more internal hard drive storage capacity, and the greater I/O bandwidth of PCIe 3.0. Its high quality is backed by high availability features including redundant SD cards for failsafe hypervisors and soft, fault-tolerant fans, and optional features such as redundant high-efficiency power supplies and hot-plug hard drives.

Comparison of PowerEdge systems

The T420 is the new generation PowerEdge server replacing the T410. Table 2 compares some of the T420 features to the T410 features.

Table 2. Comparing the PowerEdge T410 to PowerEdge T420

Feature	PowerEdge T410	PowerEdge T420
Chassis	5U tower	5U rackable tower ¹
Processors	Intel Xeon processors 5500 and 5600 series	Intel Xeon processor E5-2400 product family
Internal interconnect	Intel QuickPath Interconnect	Intel QuickPath Interconnect
Memory²	Up to 8 x DDR3 RDIMM and UDIMM	Up to 12 x DDR3 RDIMM and UDIMM
Hard drive bays	Up to 6 x 3.5" or 2.5" hot-plug or cabled	16 x 2.5" hot-plug or 8 x 3.5"/2.5" hot-plug or 4 x 3.5" cabled
RAID controller	PERC 6/i, SAS 6/iR, PERC 6/E, H200, H700, H800, S100, S300	PERC H310, H710, H710P, H810, S110
PCI slots	Up to 4 PCIe 2.0 and 1 PCIe 1.0	Up to 4 PCIe 3.0 and 2 PCIe 2.0
Embedded NICs	Dual Broadcom [®] 1GbE LOM	Dual Broadcom 1GbE LOM
Power supplies	Non-redundant 525W Redundant 580W	Non-redundant 550W or hot-plug, redundant 495W, 750W, or 1100W
Dell OpenManage Systems Management	Dell OpenManage Dell Management Console (DMC) Lifecycle Controller 1.x iDRAC6 (Express or Enterprise) with Lifecycle Controller	OpenManage Essentials Dell Management Console IT Assistant OMSA Agent OpenManage Power Center (requires iDRAC7 Enterprise with Lifecycle Controller) OpenManage Integrations and Connections Basic management (standard option)
Internal GPU	Not supported	Up to 2 single-width or 1 double-width
Power efficiency	Gold	Platinum
Availability	Hot-plug drives Hot-plug redundant power supply units	Hot-plug drives Hot-plug redundant power supply units Fan fault tolerance Fault-resilient memory Internal dual SD modules

¹Optional kit available for field conversion from tower to rackable unit.

²GB means 1 billion bytes and TB equals 1 trillion bytes; actual capacity varies with preloaded material and operating environment and will be less.



Specifications

Table 3 summarizes the specifications for each of the PowerEdge T420 features. For the latest information on supported features for the PowerEdge T420, visit Dell.com.

Table 3. Technical specifications

Feature	PowerEdge T420 technical specification		
Form factor	5U rackable tower ¹		
Processors	Intel Xeon processor E5-2400 product family		
Processor sockets	2 sockets		
Internal interconnect	1 Intel QuickPath Interconnect (QPI) link: 6.4GT/s, 7.2GT/s, 8.0GT/s		
Cache	2.5MB per core with core options of 4, 6, or 8		
Chipset	Intel C600		
Memory ²	Up to 384GB (12 DIMM slots): 2GB/4GB/8GB/16GB/32GB DDR3 up to 1600MT/s		
PCIe slots	6 PCIe slots <ul style="list-style-type: none"> • 2x16 slots with x16 bandwidth, 3.0, full-height, full-length • 1x 8 slot with x4 bandwidth, 3.0, full-height, half-length • 1x 8 slot with x4 bandwidth, 2.0, full-height, half-length • 1x 8 slot with x4 bandwidth, 3.0, full-height, full-length • 1x 8 slot with x1 bandwidth, 2.0, full-height, full-length 		
RAID controller	<table border="0"> <tr> <td style="vertical-align: top;"> Internal controllers: PERC S110 (SW RAID) PERC H310 PERC H710 PERC H710P </td> <td style="vertical-align: top;"> Internal HBAs (non-RAID): Internal tape adapter External HBAs (RAID): PERC H810 External HBAs (non-RAID): 6Gbps SAS HBA </td> </tr> </table>	Internal controllers: PERC S110 (SW RAID) PERC H310 PERC H710 PERC H710P	Internal HBAs (non-RAID): Internal tape adapter External HBAs (RAID): PERC H810 External HBAs (non-RAID): 6Gbps SAS HBA
Internal controllers: PERC S110 (SW RAID) PERC H310 PERC H710 PERC H710P	Internal HBAs (non-RAID): Internal tape adapter External HBAs (RAID): PERC H810 External HBAs (non-RAID): 6Gbps SAS HBA		
Hard drives	Drive bay options: 4 x 3.5" cabled SAS or SATA drives or 8 x 3.5" or 2.5" hot-plug SAS, SATA or SSD drives or 16 x 2.5" hot-plug SAS, SATA or SSD drives Hot-plug hard drive options: 2.5" SATA (7.2K), nearline SAS (7.2K), SAS (15K, 10K), SAS SSD, SATA SSD 3.5" SATA (7.2K), nearline SAS (7.2K), SAS (15K) Self-encrypting drives available Cabled hard drive options: 3.5" SATA or SAS		
Embedded NIC	Broadcom 5720 1GbE Dual Port LOM		
I/O adapter options	1Gb Ethernet: Broadcom 5720 Dual Port 1Gb Base-T Broadcom 5719 Quad Port 1Gb Base-T Intel I350 Dual Port 1Gb Base-T Intel I350 Quad Port 1Gb Base-T		



Feature	PowerEdge T420 technical specification
	<p>10Gb Converged Ethernet: Brocade® BR1020 Dual Port 10Gb SPF+ QLogic® QLE8262 Dual Port 10Gb DA/SFP+ Broadcom 57810S Dual Port 10Gb Base-T Broadcom 57810S Dual Port 10Gb DA/SFP+</p> <p>10Gb Ethernet: Intel X520 Dual Port 10Gb DA/SFP+ Intel X540 Dual Port 10Gb Base-T</p> <p>FC8/FC4 HBA: QLogic QLE2460 Single Port 4Gbps QLogic QLE2462 Dual Port 4Gbps QLogic QLE2560 Single Port 8Gbps QLogic QLE2562 Dual Port 8Gbps Emulex® LPe-12000-E Single Port 8Gbps Emulex LPe-12002-E Dual Port 8Gbps Brocade 815 Single Port 8Gbps Brocade 825 Dual Port 8Gbps</p>
Power supply	Platinum efficiency 495W, 750W or 1100W power supply Silver efficiency cabled 550W power supply Auto-ranging power supplies
Availability	Optional high-efficiency, hot-plug, redundant power supplies; hot-plug hard drives; TPM; dual internal SD support; redundant fans; optional bezel; information tag; ECC memory; interactive LCD screen; extended power range; ENERGY STAR® compliant; switch independent partitioning
Dell OpenManage Systems Management (Agent-free or with OpenManage Server Administrator [OMSA] Agent)	<ul style="list-style-type: none"> • OpenManage Essentials • Dell Management Console • IT Assistant • OMSA Agent • OpenManage Power Center (requires iDRAC7 Enterprise with Lifecycle Controller) • OpenManage Integrations and Connections: <ul style="list-style-type: none"> – OpenManage Integration Suite for Microsoft® System Center – Dell Management Plug-in for VMware® vCenter™ – Connections for HP® Operations Manager, IBM® Tivoli® Netcool® and CA Network and Systems Management • Basic management (standard option) <ul style="list-style-type: none"> – Upgrade to iDRAC7 (Express or Enterprise) with Lifecycle Controller – Upgrade to 8GB vFlash media or 16GB vFlash media for iDRAC7 Enterprise with Lifecycle Controller – Trial evaluations available for iDRAC7 (Express and Enterprise) with Lifecycle Controller
Rack support	ReadyRails™ II sliding rails for tool-less mounting in 4-post racks with square or unthreaded round holes or tooled mounting in 4-post threaded hole racks, with support for optional tool-less cable management arm
Operating systems	Microsoft Windows Server® 2012 Microsoft Windows Server 2008 R2 SP1, x64 (includes Hyper-V® v2) Microsoft Windows® Small Business Server 2011 SUSE® Linux® Enterprise Server Red Hat® Enterprise Linux®



Optional embedded hypervisors:

Citrix® XenServer®

VMware vSphere including ESX™ and ESXi

Red Hat Enterprise Virtualization®

For more information on the specific versions and additions, visit
Dell.com/OSsupport.

¹Optional kit available for field conversion from tower to rackable unit.

²GB means 1 billion bytes and TB equals 1 trillion bytes; actual capacity varies with preloaded material and operating environment and will be less.



3 Chassis views and features

The Dell PowerEdge T420 is a 5U, 2-socket, rackable tower server. For additional system views and features, see the *Dell PowerEdge T420 Systems Owner's Manual* on Support.Dell.com/Manuals.

Chassis views

Table 4 lists the possible chassis configurations available for the T420.

Table 4. Chassis configurations

Number of drive bays	Drive types	Controller	Front control panel	Power supply	Rack option
4 cabled drive bays	3.5" SATA and SAS HDD	PERC S110, H310, H710, H710P	LED	Cabled 550W	No
8 hot-plug drive bays	3.5" SATA and SAS HDD 2.5" SAS SSD/HDD	PERC S110, H310, H710, H710P	LCD	Cabled 550W or hot-plug 495W, 750W, or 1100W	Yes
16 hot-plug drive bays	2.5" SATA and SAS SSD/HDD	PERC H310, H710, H710P	LCD	Hot-plug 495W, 750W, 1100W	Yes

Figure 1 shows the features on the front of the T420 16-drive bay chassis including the front control panel, USB connectors, and many other components and features described in this guide.

Figure 1. Front view 16-drive bay without bezel



Figure 2 shows the optional lockable bezel on the front of the T420 chassis.

Figure 2. Front view with bezel



Figure 3 shows the features on the back panel of the T420 including USB connectors, Ethernet connectors, serial connector, video connector, PCIe slots, power supplies, iDRAC dedicated port, and many other components and features described in this guide.

Figure 3. Back view



The chassis design of the T420 is optimized for easy access to components and for airflow for effective and efficient cooling. Figure 4 provides an internal view of the T420 including the DIMMs, PCIe card slots, power supplies, fans, and processors.

Figure 4. Internal view



Figure 5 shows the front view of the rackable T420 chassis without a bezel.

Figure 5. Rackable front view without bezel



Chassis features

Table 5 lists the various features on the T420. For additional information, see the *Dell PowerEdge T420 Systems Owner's Manual* on Support.Dell.com/Manuals.

Table 5. Chassis features

Feature	Description
Power button	ACPI-compliant power button with an integrated green power LED
Front bezel	Covers the system's front-loading hard drives and locks for security
NMI button	Used to troubleshoot software and device driver errors; use only if directed to do so by qualified support personnel or by the operating system's documentation
System identification button	Buttons on the back and front of a system to help identify the unit in a data center environment
Hard drives	Up to sixteen 2.5-inch drives
USB connectors	Connects USB devices to the server
Information tag	Slide-out label panel for recording system information
Video connector	Connects a monitor to the server; the tower chassis has one port on the back of the chassis; the rack chassis has a port on both the front and back of the chassis
LCD panel and buttons	Displays system ID, status information, and system error messages; the hot-plug chassis has two navigation buttons to scroll through the menu on the LCD and one select button
Optical drive	Optional half-height DVD or DVD+RW drive
Power supply units	Supplies power to the server
Power supply indicators	Indicates whether server has power
NIC indicators	Indicates network activity and status
PCIe slots	Connects PCIe expansion cards to the server
Ethernet connectors	Connects integrated 10/100/1000 NICs to the server
Serial connector	Connects a serial device to the server
iDRAC7 Enterprise port	Dedicated management port for optional iDRAC Ports card



Front control panel

The T420 control panel is located on the front of the chassis as shown in Figure 6. For more information about the LCD control panel, see the *Dell PowerEdge T420 Systems Owner's Manual* on Support.Dell.com/Manuals.

Figure 6. LCD control panel



Quick Resource Locator

A useful feature included with Dell PowerEdge 12th generation servers is the Quick Resource Locator (QRL)—a model-specific Quick Response (QR) code that is located inside the T420 chassis cover (see Figure 7). Use your smartphone to access the Dell QRL app to learn more about the server.

Figure 7. QRL location



This QRL code allows you to:

- View step-by-step videos, including overviews of system internals and externals, as well as detailed, concise, task-oriented videos and installation wizards
- Locate reference materials, including searchable owner's manual content, LCD diagnostics, and an electrical overview
- Look up your service tag so you can quickly gain access to your specific hardware configuration info and warranty information
- Contact Dell directly (by link) to get in touch with technical support and sales teams and provide feedback to Dell

These codes provide an easy way to retrieve the critical support information you need when you need it, making you more efficient and effective in managing your hardware.



Security features

The latest generation of PowerEdge servers has the features listed in Table 6 to help ensure the security of your data center.

Table 6. Security features

Security feature	Description
Cover latch	A tooled latch is integrated on the chassis (top of rack chassis or side of tower chassis) with a coin key lock to secure the system.
Bezel	An optional metal bezel is mounted to the chassis front to provide the Dell ID. A lock on the bezel protects un-authorized access to the hard drives and optical drive. Although the bezel has an open area to allow access to the tape backup in bay 2, the rest of the system remains locked. System status is viewable on the LCD screen when the bezel is installed.
TPM	The Trusted Platform Module (TPM) is used to generate/store keys, protect/authenticate passwords, and create/store digital certificates. It also supports the Intel Xeon TXT functionality. TPM can also be used to enable the BitLocker™ hard drive encryption feature in Windows Server 2008. TPM 1.2 is supported. No TPM version is available for China or Russia.
Power-off security	BIOS has the ability to disable the power button function.
Intrusion alert	An internal switch is used to detect chassis intrusion.
Secure mode	BIOS has the ability to enter a secure boot mode through system setup. This mode includes the option to lock out the power and NMI switches on the control panel or set up a system password.



4 Processor

The Dell PowerEdge T420 features the Intel Xeon processor E5-2400 product family, which offers an ideal combination of performance, power efficiency, and cost. These processors provide substantial performance and capacity for entry and mainstream workloads, as well as applications requiring significant memory and I/O scalability no matter what your constraint is—floor space, power, or budget. In addition to providing raw performance gains, improved I/O is also made possible with Intel Integrated I/O, which can reduce latency by adding more lanes and doubling bandwidth. This helps to reduce network and storage bottlenecks, unleashing the processor's performance capabilities.

Processor features

The new Intel Xeon processor E5-2400 product family provides the following features:

- 2-socket processor design with power and dimensions optimized for density
- Up to 8 execution cores per processor
- Intel Hyper-Threading technology enables up to 16 computational threads
- Micro-architecture on 32nm process for greater performance per watt
- Support for more memory—4 additional DIMMs (up to 12 DIMM slots) and support for up to 32GB DIMMs increasing the memory capacity from 128GB to 384GB
- Integrated memory controller with 3 channels of DDR3 and 46-bit physical addressing facilitate greater memory capacity
- Intel Integrated I/O has support for up to 24 lanes per socket of PCIe 3.0 links (for more information on PCIe lanes, see the specifications in the System features section)
- Faster connections throughout the system with support for DDR3 1600MT/s memory and 8.0GT/s QPI
- Intel Data Direct I/O (DDIO) allows I/O traffic to skip the main system memory and be directed straight to the processor cache, which can provide a significant reduction in latency as well as allowing memory to remain in a low-power state
- High bandwidth, low latency, bidirectional ring interconnect allows faster access to the 20MB multi-banked last level cache
- Intel Advanced Vector Extensions offer up to double the floating point operations per clock cycle by doubling the length of registers, which can be useful for addressing very complex problems or dealing with large-number calculations, which are integral to many technical, financial, and scientific computing problems
- Intel Turbo Boost Technology 2.0, which allows processor cores to run faster than the base operating frequency if it's operating below power, current, and temperature specification limits, delivers up to double the boost than the previous generation
- Continued improvements to both Intel TXT and AES-NI help to better protect systems and data

For more information on the Intel Xeon processor E5-2400 product family, visit Intel.com.

Supported processors

Table 7 lists the Intel Xeon processors supported by the PowerEdge T420. For the latest information on supported processors, visit Dell.com/PowerEdge.



Table 7. Supported processors

Model	Speed	TDP	Cache	Cores/ threads	QPI	Max memory speed	Turbo
E5-2450	2.1GHz	95W	20MB	8/16	8.0 GT/s	1600MT/s	Yes
E5-2440	2.4GHz	95W	15MB	6/12	7.2 GT/s	1333MT/s	Yes
E5-2430L	2.0GHz	60W	15MB	6/12	7.2 GT/s	1333MT/s	Yes
E5-2430	2.2GHz	95W	15MB	6/12	7.2 GT/s	1333MT/s	Yes
E5-2420	1.9GHz	95W	15MB	6/12	7.2 GT/s	1333MT/s	Yes
E5-2407	2.2GHz	80W	10MB	4/8	6.4 GT/s	1066MT/s	NA
E5-2403	1.8GHz	80W	10MB	4/8	6.4 GT/s	1066MT/s	NA

For information on processor installation and configuration, see the *Dell PowerEdge T420 Systems Owner's Manual* on Support.Dell.com/Manuals.

GPU support

The T420 supports graphics processing unit (GPU) technology, providing accelerated performance for a variety of applications such as VDI and medical imaging.

GPU cards

The T420 supports two nVidia® Q4000 full-length, single-width or one nVidia Q6000 full-length, double-width GPU. GPU cards are available through certified factory installation (CFI) or field upgrade only.

Each GPU supports up to 6GB of dedicated GDDR5 memory and is actively cooled. Each GPU has one or two power connectors to meet the high demand for power delivery. The power connectors are located on the back of the card.

GPU configuration options

The GPUs from nVidia have PCIe 2.0 that can be installed in the T420 PCIe x16 3.0 slots 3 and 5 (slot 5 requires a two-processor configuration). The interface for the next generation GPU cards will be PCIe 3.0.

The following system configuration restrictions apply when a GPU is installed:

- 1100W redundant power supply is recommended
- System can support only one 5.25-inch device

Operating system support for GPUs

Some operating systems have not been validated to support GPUs. See Table 20 for more information on operating system support of GPUs.

Chipset

The Intel C600 chipset is implemented on the PowerEdge T420. For more information, visit Intel.com.



5 Memory

More options are available for the Dell PowerEdge 12th generation servers than in previous generations—more capacity choices and more frequency choices. The PowerEdge T420 supports up to 384GB of memory with speeds of up to 1600MT/s, providing high performance in a variety of applications. The new reliability, availability, serviceability (RAS) features like memory mirroring and sparing help you increase your uptime and reduce data loss. RAS aids in the rapid and accurate diagnosis of faults that require service, increasing your memory reliability.

Supported memory

The T420 supports the memory technologies shown in Table 8.

Table 8. Memory technologies supported

Feature	UDIMM	RDIMM
Register	No	Yes
Buffer	No	No
Frequencies*	800, 1066, or 1333MT/s	800, 1066, 1333, or 1600MT/s
Ranks supported	1 or 2	1, 2, or 4
Capacity per DIMM	2 or 4GB	2, 4, 8, 16, or 32GB
Maximum DIMMs per channel	2	2
DRAM technology	x8	x4 or x8
Temperature sensor	Yes	Yes
Error Correction Code (ECC)	Yes	Yes
Single Device Disable Code (SDDC)	Yes (with advanced ECC mode)	Yes
Address parity	Yes	Yes

*Although the T420 supports DIMM speeds of 800MT/s and 1066MT/s, you can only purchase this system with DIMM speeds of 1333MT/s and 1600MT/s on [Dell.com](https://www.dell.com).



The T420 supports the DIMMs listed in Table 9. For the latest information on supported memory, visit Dell.com.

Table 9. DIMMs supported

Capacity (GB)	Speed (MT/s)	Type	Ranks per DIMM	Data width	SDDC support	Voltage
2	1333	RDIMM	1	x8	Advanced ECC	1.35
2	1333	UDIMM	1	x8	Advanced ECC	1.35
2	1600	RDIMM	1	x8	Advanced ECC	1.5
4	1333	RDIMM	2	x8	Advanced ECC	1.35
4	1333	RDIMM	1	x4	All modes	1.35
4	1333	UDIMM	2	x8	Advanced ECC	1.35
4	1600	RDIMM	2	x8	Advanced ECC	1.5
8	1333	RDIMM	2	x4	All modes	1.35
8	1600	RDIMM	2	x4	All modes	1.5
16	1333	RDIMM	2	x4	All modes	1.35
16	1600	RDIMM	2	x4	All modes	1.5
32	1333	RDIMM	4	x4	All modes	1.35

Memory configurations

Flexible memory configurations are supported on the T420, ranging from capacities of 2GB to 384GB. The system supports up to 6 DIMMs per processor (up to 12 DIMMs in a 2-processor configuration). The T420 has 3 memory channels per processor, with each channel supporting up to 2 DIMMs.

The T420 supports a flexible memory configuration according to these basic rules:

- Speed: If DIMMs of different speeds are mixed, all channels across all processors operate at the slowest DIMM's common frequency.
- DIMM type: Only one type of DIMM can be used in a system. UDIMMs and RDIMMs cannot be mixed.

The following additional memory population guidelines apply to the T420:

- Up to two quad-rank (QR), dual-rank (DR), or single-rank (SR) DIMMs may be populated per channel.
- DIMMs must be installed in each channel, starting with the DIMM farthest from the processor.
- DIMMs should be installed with largest rank count to smallest. For example, if DR DIMMs are mixed with SR DIMMs, DR DIMMs should be placed in the lowest DIMM slots, followed by the SR DIMMs.

For more information on memory configuration, see the *Dell PowerEdge T420 Systems Owner's Manual* on Support.Dell.com/Manuals.



Memory speed

The T420 supports memory speeds of 1600MT/s, 1333MT/s, 1066MT/s, and 800MT/s depending on the DIMM types installed and the configuration. All memory on all processors and channels run at the same speed and voltage. By default, the systems run at the highest speed for the channel with the lowest DIMM voltage and speed. The operating speed of the memory is also determined by the maximum speed supported by the processor, the speed settings in the BIOS, and the operating voltage of the system.

Table 10 lists memory configuration and performance details for the T420 based on the population of the number and type of DIMMs per memory channel.

Table 10. Memory speed capabilities

DIMM type	DIMM 0	DIMM 1	Number of DIMMs	Speed (MT/s)			
				800*	1066*	1333	1600
UDIMM	SR		1	•	•	•	
	DR		1	•	•	•	
	SR	SR	2	•	•	•	
	SR	DR	2	•	•	•	
	DR	DR	2	•	•	•	
RDIMM	SR		1	•	•	•	•
	DR		1	•	•	•	•
	QR		1	•	•	•	
	SR	SR	2	•	•	•	•
	SR	DR	2	•	•	•	•
	DR	DR	2	•	•	•	•
	QR	SR	2	•	•		
	QR	DR	2	•	•		
	QR	QR	2	•	•		

*Although the T420 supports DIMM speeds of 800MT/s and 1066MT/s, you can only purchase this system with DIMM speeds of 1333MT/s and 1600MT/s on Dell.com.

Memory RAS features

RAS features help keep the system online and operational without significant impact to performance, and can decrease data loss and crashing due to errors. RAS aids in rapid, accurate diagnosis of faults that require service. Table 11 describes the RAS features supported on the T420.

Table 11. Memory RAS features

Feature	Description
Dense configuration optimized profile	Increased memory reliability can be a result from this selectable platform profile that adjusts parameters to reduce faults regarding refresh rates, speed, temperature and voltage



Feature	Description
Memory demand and patrol scrubbing	Demand scrubbing is the ability to write corrected data back to the memory once a correctable error is detected on a read transaction. Patrol scrubbing proactively searches the system memory, repairing correctable errors.
Recovery from single DRAM device failure	Recovery from Single DRAM Device Failure (SDDC) provides error checking and correction that protects against any single memory chip failure as well as multi-bit errors from any portion of a single memory chip.
Failed DIMM isolation	This feature provides the ability to identify a specific failing DIMM channel pair, thereby enabling the user to replace only the failed DIMM pair.
Memory mirroring: intra-socket	Memory mirroring is a method of keeping a duplicate (secondary or mirrored) copy of the contents of memory as a redundant backup for use if the primary memory fails. The mirrored copy of the memory is stored in memory of the same processor socket.
Memory address parity protection	This feature provides the ability to detect transient errors on the address lines of the DDR channel.
Memory sparing (rank)	Memory sparing allocates one rank per channel as a spare. If excessive correctable errors occur in a rank or channel, it is moved to the spare area while the operating system is running to prevent the error from causing an uncorrectable failure.
Memory thermal throttling	This feature helps to optimize power/performance and can also be used to prevent DIMMs from overheating.

For information on memory mirroring and sparing configurations, see the *Dell PowerEdge T420 Systems Owner's Manual* on [Support.Dell.com/Manuals](https://support.dell.com/manuals).



6 Storage

The Dell PowerEdge T420 supports internal and external storage options and controllers, different drive types, and different chassis configurations for a varied number of drives.

Internal storage

The T420 has one chassis that supports three different drive bay options:

- 4 x 3.5-inch cabled drive bays
- 8 x 2.5-inch or 3.5-inch hot-plug drive bays
- 16 x 2.5-inch hot-plug drive bays

Supported hard drives

The T420 supports up to sixteen 2.5-inch or eight 3.5-inch hard drives or solid-state drives. Self-encrypting drives (SED) are available. Table 12 lists more information about these drives. For additional information, see Dell.com/PowerEdge.

Table 12. Supported hard drives

Form factor	Type	Speed (rpm)	Capacities
2.5"	Nearline SAS	7.2K	500G, 1TB
	SAS	10K	300GB, 600GB, 900GB
	SAS	15K	146GB, 300GB
	SAS SSD	N/A	200GB, 400GB
	SATA SSD	N/A	100GB, 200GB
	SATA	7.2K	250GB, 500GB, 1TB
3.5"	SATA	7.2K	500GB, 1TB, 2TB, 3TB
	Nearline SAS	7.2K	1TB, 2TB, 3TB
	SAS	15K	300GB, 600GB

External storage

External storage for the T420 is available through SAS 6Gbps. For more information, see Dell.com/Storage.



Storage controllers

Dell provides highly capable RAID options for you to ensure that your data remains safe. Dell's RAID controller options offer impressive performance improvements, including the following features:

- FastPath™ I/O: This feature can help accelerate performance when operating on SSDs.
- Split mirror: This function allows you to break mirrored disk connection in order to quickly replace a drive.
- Physical disk power management (Dimmer Switch™): This feature allows for power control of spare or idle drives, which can save energy and operating expenses.

Supported RAID controllers

The newest line of PERC (PowerEdge RAID Controller) cards offer high I/O performance for database applications and streaming digital media environments. The internal RAID controllers have a dedicated connection to the system board. The T420 supports the new PERC 8 family of controllers with improved functionality and faster performance.

The T420 supports the adapter-type PERC only plus the new software RAID solution that supports RAID 0, 1, 5 and 10 as shown in Table 13. For more information about the latest PERC offerings, see Dell.com/PERC.

Table 13. Supported RAID controllers

Controller	Description	Features	RAID modes supported	Form factor	Usage model
PERC H810 External	Eight-port, external and 6Gp/s PCIe RAID controller	Includes 1GB NV DDR3 cache, premium performance and feature set, security SED/EKMS, and SSD as cache	0, 1, 10, 5, 50, 6, 60	Adapter	Premium performance
PERC H710P Internal	Eight-port, internal 6Gb/s PCIe RAID controller	Includes 1GB NV DDR3 cache, premium performance and feature set, security SED/EKMS, and SSD as cache	0, 1, 10, 5, 50, 6, 60	Adapter	Premium performance
PERC H710 Internal	Eight-port, internal 6Gb/s PCIe RAID controller	Includes 512MB NV DDR3 cache, advanced feature set, security SED/EKMS	0, 1, 10, 5, 50, 6, 60	Adapter	Performance
PERC H310 Internal	Eight-port, internal 6Gb/s PCIe RAID	Supports hot-plug drives, expansion, pass-through	0, 1, 10, 5, 50	Adapter	Value



Controller	Description	Features	RAID modes supported	Form factor	Usage model
PERC S110 Software RAID	3Gb/s SATA software RAID controller that supports up to 4 physical disks or 8 virtual disks	Supports up to 4 hot-plug SATA drives , no expansion, Microsoft Windows only	0, 1, 5, 10	System board-embedded SATA	Entry-level

Optical drive

The T420 hot-plug chassis supports up to three media bays through one of the following options:

- Up to two SATA half-height DVD-ROM or DVD R/W drive + one SAS interface tape drive
- Up to one SATA half-height DVD-ROM or DVD R/W drive + one internal RD1000 drive+ one SAS interface tape drive.

The T420 cabled chassis supports up to two media bays through one of the following options:

- Up to two SATA half-height DVD-ROM or DVD R/W drive
- Up to one SATA half-height DVD-ROM or DVD R/W drive + one internal RD1000 drive/or SAS interface tape drive
- Up to one internal RD1000 drive+ one SAS interface tape drive

Tape drive

The T420 supports the external storage device types listed in Table 14. For additional information, visit Dell.com/Storage.

Table 14. Supported external storage

Tape devices	Interface cards
LTO5-140 SAS	Internal tape adapter
LTO4-120 HH SAS	Internal tape adapter
LTO3-080 SAS	Internal tape adapter
RD1000 SATA	Onboard SATA
External SAS tape	6Gb SAS HBA
External FC tape	FC HBA
External RD1000	USB



7 Networking and PCIe

The Dell PowerEdge T420 offers balanced, scalable I/O capabilities, including integrated PCIe 3.0 capable expansion slots. The T420 supports up to six PCIe slots.

Embedded NIC controller

The T420 system board has one embedded NIC controller. The Broadcom 5720 Gigabit NIC chip is connected to the platform controller hub through a PCIe 2.0 x 2 link.

The Broadcom 5720 is a 14th generation 10/100/1000Base-T Ethernet LAN controller solution suitable for high-performance server applications. The Broadcom 5720 combines dual triple-speed IEEE 802.3 compliant Media Access Controllers (MACs) with dual 10/100/1000 Ethernet transceivers (PHYs), selectable individually per port, a network controller sideband interface (NC-SI), and an on-chip memory buffer in a single device. The device provides a PCIe 2.1-compliant interface, which operates at 5GT/s or 2.5GT/s x2 link width.

PCIe expansion

The T420 provides expanded PCIe slot capability over the previous servers. This is made possible by the 24 PCIe lanes available from each processor in the system. Dell designed the T420 to be PCIe 3.0-compliant in order to take full advantage of the processor capabilities.

PCIe slots

PCIe connectivity is integrated with the processor in that the number of processors in a system impacts the number of PCIe slots and the bandwidth of each PCIe slot. For a system with one processor, five of the PCIe slots are available. For a system with two processors, all six slots are available.

PCIe expansion cards

The T420 supports a variety of PCIe expansion cards. Table 15 lists the supported add-in NICs and HBAs for the T420.

Table 15. Supported NICs and HBAs

Type	Adapter
1Gb/10Gb NICs	Broadcom 5720 Dual Port 1Gb Base-T
	Broadcom 5719 Quad Port 1Gb Base-T
	Intel I350 Dual Port 1Gb Base-T
	Intel I350 Quad Port 1Gb Base-T
	Broadcom 57810S Dual Port 10Gb Base-T CNA
	Broadcom 57810S Dual Port 10Gb DA/SFP+ CNA
	Intel X520 Dual Port 10Gb SFP+



Type	Adapter
	Intel X540 Dual Port 10Gb Base-T
	QLogic QLE8262 Dual Port 10Gb DA/SFP+
	Brocade BR1020 Dual Port 10Gb SFP+ CNA
FC4/FC8 HBAs	QLogic QLE2460 Single Port 4Gbps
	QLogic QLE2462 Dual Port 4Gbps
	QLogic QLE2560 Single Port 8Gbps
	QLogic QLE2562 Dual Port 8Gbps
	Emulex LPe12000 Single Port 8Gbps
	Emulex LPe12002 Dual Port 8Gbps
	Brocade BR815 Single Port 8Gbps
	Brocade BR825 Dual Port 8Gbps

For the latest information on all supported add-in PCIe expansion cards for the T420, visit Dell.com.



8 Power, thermal, and acoustics

Lower overall system-level power draw is a result of breakthrough system design. The Dell PowerEdge T420 server maximizes performance per watt through a combination of power and cooling, energy efficient technologies, and tools. Additionally, the PowerEdge T420 has an extensive collection of sensors that automatically track thermal activity, which helps regulate temperature thereby reducing server noise and power consumption.

Power consumption and energy efficiency

With the rise in the cost of energy coupled with increasing data center density, Dell provides tools and technologies to help you realize greater performance with less energy cost and waste. More efficient data center usage can reduce costs by slowing the need for additional center space. Table 16 lists the tools and technologies Dell offers to help you achieve your data center goals by lowering power consumption and increasing energy efficiency.

Table 16. Power tools and technologies

Feature	Description
Power supply unit (PSU) portfolio (redundant PSU only)	Dell's PSU portfolio includes intelligent features such as dynamically optimizing efficiency while maintaining availability and redundancy. Find additional information in the Power supply units section.
Tools for right-sizing	Dell Energy Smart Solution Advisor (ESSA) is a tool that helps you determine the most efficient configuration possible. With ESSA, you can calculate the power consumption of your hardware, power infrastructure, and storage. ESSA can help you determine exactly how much power your server will use at a given workload, and the PSU Advisor can help you choose the best, most efficient PSU for your workload. Learn more at Dell.com/calc . Energy Smart Data Center Assessment is a Dell Services offering that uses infrastructure and thermal analysis to help maximize system efficiency. Learn more at Dell.com/EnergySmart .
Industry compliance	Dell's servers are compliant with all relevant industry certifications and guidelines, including 80 PLUS, Climate Savers, and ENERGY STAR.
Power monitoring accuracy (redundant PSU only)	PSU power monitoring improvements include: <ul style="list-style-type: none">• Dell's power monitoring accuracy is currently 1%, whereas the industry standard is 5%• More accurate reporting of power• Better performance under a power cap
Power capping (redundant PSU only)	Use Dell's systems management to set the power cap limit for your systems to limit the output of a PSU and reduce system power consumption. Dell is the first hardware vendor to leverage Intel Node Manager for circuit-breaker fast capping.
Systems management (redundant PSU only)	iDRAC7 Enterprise provides server-level management that monitors, reports, and controls power consumption at the processor, memory, and system level. Dell OpenManage Power Center delivers group power management at the rack, row, and data center level for servers, power distribution units, and uninterruptible power supplies.



Feature	Description
Active power management (redundant PSU only)	<p>Intel Node Manager is an embedded technology that provides individual server-level power reporting and power limiting functionality. Dell offers a complete power management solution comprised of Intel Node Manager accessed through Dell iDRAC7 Enterprise and OpenManage Power Center that allows policy-based management of power and thermals at the individual server, rack and data center level.</p> <p>Hot spare reduces power consumption of redundant power supplies.</p> <p>Thermal control of fan speed optimizes the thermal settings for your environment to reduce fan consumption and lower system power consumption.</p> <p>Idle power enables Dell servers to run as efficiently when idle as when at full workload.</p>
Fresh Air cooling (redundant PSU only)	<p>With the thermal design and reliability of Dell products, you can have the capability to operate at excursion-based temperatures beyond the industry standard of 35°C (95°F) without impacting your availability model. This solution takes into account servers, networking, storage, and other infrastructure. Find additional information at Dell.com/FreshAir.</p>
Rack infrastructure	<p>Dell offers some of the industry's highest-efficiency power infrastructure solutions, including:</p> <ul style="list-style-type: none"> • Power distribution units (PDUs) • Uninterruptible power supplies (UPS) • Energy Smart containment rack enclosures <p>Find additional information at http://content.dell.com/us/en/enterprise/power-and-cooling-technologies-components-rack-infrastructure.aspx.</p>

Find additional information at Dell.com/PowerAndCooling and Power.com/PowerCenter.

Power supply units

Energy Smart power supplies (redundant PSUs only) have intelligent features, such as the ability to dynamically optimize efficiency while maintaining availability and redundancy. Also featured are enhanced power-consumption reduction technologies, such as high-efficiency power conversion and advanced thermal-management techniques, and embedded power-management features, including high-accuracy power monitoring.

The T420 power supply subsystem consists of a single, cabled power supply or up to two AC-DC redundant power supplies. The following power supply options are available for the T420:

- 550W AC, cabled, non-redundant
- 495W AC, hot-plug redundant
- 750W AC, hot-plug redundant
- 1100W AC, hot-plug redundant



Figure 8 shows a 750W power supply unit extended from the T420 chassis.

Figure 8. 750W power supply unit



The PowerEdge T420 supports up to two PSUs with 1+1 redundancy, auto-sensing, and auto-switching capability. The T420 also supports PSU 2+0 configurations for configurations that exceed the output of a single PSU; in this case, 1+1 redundancy is not supported. Use the Dell Energy Smart Solution Advisor at Dell.com/ESSA to help you configure your system optimal power performance.

Dell PSUs have achieved Platinum efficiency levels as shown in Table 17.

Table 17. Power supply efficiency

Form factor	Output	Class	Efficiency targets by load			
			10%	20%	50%	100%
Redundant 86mm	495W AC	Platinum	82.0%	90.0%	94.0%	91.0%
	750W AC	Platinum	82.0%	90.0%	94.0%	91.0%
	1100W AC	Platinum	89.0%	93.0%	94.5%	92.0%
Non-redundant	550W AC	Silver	N/A	85.0%	88.0%	85.0%

Thermal and acoustics

Optimized thermal management makes the PowerEdge T420 cool and quiet. Benefiting from smart cooling fan speed control, the T420 can keep both high performance and good acoustics across a wide range of ambient temperatures from 10°C to 35°C (50°F to 95°F) and to extended ambient temperature ranges (see Table 26). Operating environments for the T420 can vary from the data center to general-use spaces. In a typical configuration, the T420 is suitable for an open office environment.



Thermal design

The thermal design of the PowerEdge T420 reflects the following:

- **Multiple sensors are monitored for thermal feedback control:** The PowerEdge T420 dynamically controls system cooling fan speed based on responses from component temperature sensors, including processors, hard disk drives, DIMMs, storage cards, and the inlet ambient temperature. Thermal control detects and responds to hardware configuration. Thermal management adjusts cooling according to what the system really needs, and draws lower fan power draw and generates lower acoustical noise levels than servers without such controls.
- **Environmental specifications:** The optimized thermal management makes the T420 reliable under a wide range of operating environments as shown in the environmental specifications in Table 26. Many configurations are also compliant under expanded operating temperature environments, but a few are not.

Acoustical design

The acoustical design of the PowerEdge T420 reflects the following:

- **Quiet library acoustics:** The PowerEdge T420 is quiet enough for an office setting when minimally configured and for the office under the desk with a typical configuration.
- **Adherence to Dell's high sound quality standards:** Sound quality is different from sound power level and sound pressure level in that it describes how humans respond to annoyances in sound, like whistles, hums, and so on. One of the sound quality metrics in the Dell specification is prominence ratio of a tone, which is listed in Table 18.
- **Configurable for low acoustics:** The following are configuration considerations you should make if acoustics is important to you:
 - Storage devices:
 - > Because hard drive noise scales with spindle speed, the quietest option for rotational storage media is a 7200-rpm SATA drive. The loudest option is a 15k SAS drive.
 - > Solid-state drives are even quieter than rotational drives because they have no sound associated with spinning.
 - > Noise levels increase with the quantity of hard drives; using fewer hard drives will have a lower acoustical output.
 - Impact of cards:
 - > Quantity of PCIe cards: When more than two PCIe cards are installed, the system fan speed/noise level will be higher.
 - > Types of PCIe cards: The fan speed/noise level will be higher if a GPU and PERC H710 are installed.
 - **System Profile settings in BIOS and Thermal settings in iDRAC:** Performance Per Watt is the quietest option. Other options such as Performance Optimized or Dense Configuration require higher fan speeds, which produce higher acoustic levels.
 - **Hot spare feature of power supply unit:** In system default setting, the hot spare feature is disabled; acoustical output from the power supplies is lowest in this setting. If the feature is enabled and the system power loading is low, the power supply fan speed hence noise will be higher.
 - **RAID Setup with PERC H310:** A system configured as non-RAID will have a higher noise level than a system configured as RAID. With non-RAID, the temperature of the hard disk drives is not monitored, which causes the fan speed to be higher to ensure sufficient cooling resulting in higher noise level.
- **Noise ramp and descent during bootup from power off:** Fan speed noise levels ramp during the boot process (from power off to power on) to add a layer of protection for component cooling in case the system does not boot properly. To keep the bootup process as quiet as possible, the fan speed reached during bootup is limited to about half of full speed.



Table 18 details the acoustical performance for the T420.

Table 18. Acoustical performance

Configuration (23 ± 2°C ambient)	CPUs	Hard drives	Power supply unit	Memory	PCI card/HDD controller	Operating mode	L _{WA} -UL ¹ (bels)	L _{pA} ² (dBA)	Prominent tones ³
Typical	2	4 x 3.5" SAS (15K)	2 x 750W	6 x 4GB	1 x 10GbE NIC	Idle ⁴	5.1	41	Yes, by hard drive at idle and CPU at stress
					1 x PERC H710P	Stress ⁵	5.2	42	
Feature rich	2	8 x 2.5" SATA (10K)	2 x 1100W	12 x 8GB	1 x 10GbE NIC	Idle ⁴	4.7	38	Yes, by hard drive at stress
					1 x 1GbE NIC 1 x PERC H310 2 x 150W GPU	Stress ⁵	4.7	38	

¹L_{WA}-UL is the upper limit sound power levels (L_{WA}) calculated per section 4.4.1 of ISO 9296 (1988) and measured in accordance to ISO 7779 (2010).

²L_{pA} is the average bystander position A-weighted sound pressure level calculated per section 4.3 of ISO 9296 (1988) and measured in accordance with ISO 7779 (2010). The system is placed within a rack enclosure (base of system is 75 cm above floor).

³Prominent tone: Criteria of D.6 and D.11 of ECMA-74 11th ed. (2010) are followed to determine if discrete tones are prominent. The system is placed in center of ISO 7779 table and binaural head is at front operator position, reference ISO 7779 (2010) Section 8.6.1, position P4.

⁴Idle: Reference ISO 7779 (2010) definition 3.1.7; system is running in its operating system but no other specific activity.

⁵Stress: An operating mode per ISO 7779 (2010) definition 3.1.6. The software MemBW4 is activated to stress the processors.

For more information on Dell's acoustical design, see the [Dell Enterprise Acoustics](#) white paper.



9 Rack rails and cable management

The sliding rail system for the Dell PowerEdge T420 provides tool-less support for 4-post racks with square or unthreaded round mounting holes. Compared to the T610 sliding rails that required the use of adapter brackets, the sliding rails for the T420 now offer support for threaded hole racks with the ReadyRails II mounting interface.

Sliding rails

The ReadyRails II sliding rails for the T420 support tool-less mounting in 19"-wide, EIA-310-E compliant square hole and unthreaded round hole 4-post racks. The rails also support toolled mounting in threaded hole 4-post racks and are available with or without the optional cable management arm (CMA).

The rails ship in the tool-less mounting configuration, but can be easily converted to the toolled configuration. The optional CMA can be mounted on either the left or right side of the sliding rails without the use of tools for fast and easy deployment. The T420 is backward compatible with the T610 rails and CMA. The T420 supports sliding rails only. Static rails are not supported. Mounting in 2-post racks is not supported.

Figure 9 shows the sliding rails with the CMA installed.

Figure 9. Sliding rails with optional CMA

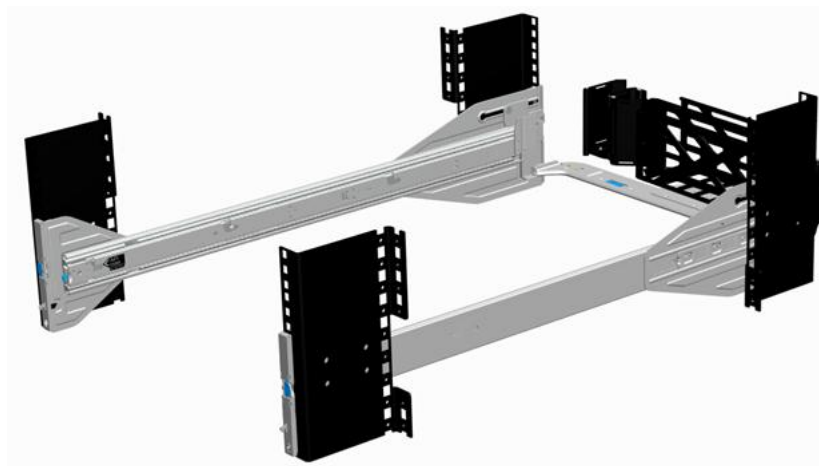

Table 19 lists the supported rack types for the T420.

Table 19. Supported rack types

Product	Rail Identifier	Mounting Interface	Rail Type	Rack Types Supported				
				4-Post			2-Post	
				Square	Round	Thread	Flush	Center
T420	C2	ReadyRails II	Sliding	✓	✓	✓	X	X

Screws are not included in the kit due to the fact that threaded racks are offered with a variety of thread designations. Other factors to consider when deploying the T420 include the spacing between the front and rear mounting flanges of the rack, the type and location of any equipment



mounted in the back of the rack such as power distribution units (PDUs), and the overall depth of the rack.

For detailed information about sliding rails, see the Rack rail specifications section in Appendix A. For more information on installing the T420 in a rack, see the *Rack Installation Instructions* on [Support.Dell.com/Manuals](https://support.dell.com/manuals).

Cable management arm

The optional CMA organizes and secures the cords and cables exiting the back of the server and unfolds to allow the server to extend out of the rack without having to detach the cables. Some key features of the T420 CMA include:

- Large U-shaped baskets to support dense cable loads
- Open vent pattern for optimal airflow
- Ability to be mounted on either side
- Use of hook-and-loop straps rather than plastic tie wraps to eliminate the risk of cable damage during cycling
- Low-profile fixed tray to both support and retain the CMA in its fully closed position
- Ability to mount the CMA and tray without the use of tools, due to snap-in designs



10 Operating systems and virtualization

The Dell PowerEdge T420 supports a wide range of industry-standard operating systems and virtualization software.

Supported operating systems

Table 20 lists the primary operating systems supported on the T420. For the latest information on supported operating systems, see Dell.com/OSsupport.

Table 20. Primary operating system support

Operating System	Platform	Edition
Red Hat Enterprise Linux 5.8 SP8	x32	N/A
	x64	
Red Hat Enterprise Linux 6.2 SP2	x64	N/A
SUSE Linux Enterprise Server 11 SP2	x64	N/A
SUSE Linux Enterprise Server 10 SP4	x64	N/A
Microsoft Windows Server 2012	x64	Standard Data center
Microsoft Windows Small Business Server 2011¹	x64	Standard Premium Add-on
Microsoft Windows Server 2008 R2 with SP1	x64 (with Hyper-V role enabled)	Web Standard Enterprise

¹Not validated for use with GPUs



Supported virtualization

One of the key features for virtualization on the PowerEdge T420 is the support for a fail-safe hypervisor. By running a hypervisor on an optional SD card and installing a backup copy on the other mirrored SD card, you can protect against hardware failure and maximize virtualization uptime.

Table 21 highlights the virtualization support for the T420.

Table 21. Virtualization support

Operating systems	Version	Options	
VMware¹	vSphere v4.1 U2	ESX Classic	DIB
	vSphere v4.1 U2	ESXi Installable	DIB
	vSphere v4.1 U2	ESXi Embedded	FI
	vSphere v5.0 U1	ESXi (one version)	FI/DIB
	vSphere v5.1	ESXi (one version)	DIB
Citrix	XenServer v6.0	N/A	DIB
Red Hat²	Enterprise Virtualization v3.0	N/A	DIB

FI = factory install; DIB = drop in box

¹vSphere Fault Tolerance is supported with these versions

²No OpenManage support; drop-in-box license registration card only



11 Dell OpenManage systems management

Whether your IT environment consists of a few servers or a few thousand servers, Dell OpenManage systems management solutions provide comprehensive management for evolving IT environments. OpenManage is based on open standards and provides agent-based and agent-free server lifecycle management functionality for Dell PowerEdge servers. OpenManage solutions help you automate and streamline essential hardware management tasks.

The advanced management capabilities of Dell OpenManage also integrates into offerings from other popular systems management solutions that you may already use, making Dell platforms easy to manage and deploy in any IT environment. This ensures your IT services are available when your business needs them. If you have already standardized on offerings from industry leaders, such as BMC Software, Microsoft, Symantec™, VMware, or other vendors, you can leverage OpenManage integration and connections developed to use with your existing systems management framework to efficiently manage Dell servers, storage, business-client PCs, and network devices.

Start with a firm foundation for efficient hardware management using OpenManage tools, utilities, and management consoles. OpenManage systems management solutions consist of a combination of embedded management features and software products that help you automate and simplify the entire server lifecycle: deploy, update, monitor, and maintain. OpenManage solutions are innovatively designed for simplicity and ease of use to help you reduce complexity, save time, achieve efficiency, control costs, and empower productivity.

Systems management solutions

Dell systems management solutions include a wide variety of tools, products, and services that enable you to leverage an existing systems management framework. As shown in Figure 10, Dell systems management solutions are centered around OpenManage server management, featuring iDRAC with Lifecycle Controller.

Figure 10. Dell systems management solutions

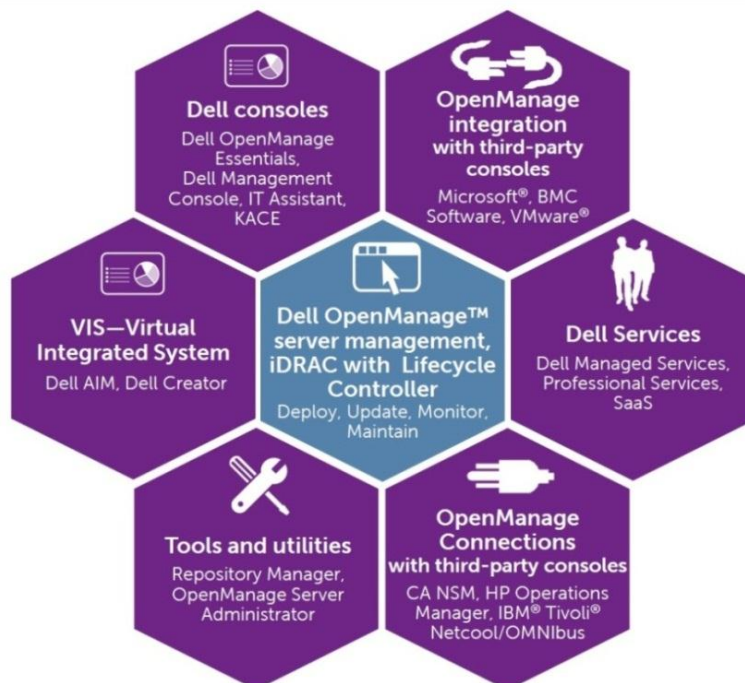

OpenManage systems management

The Dell OpenManage systems management portfolio includes powerful hardware and software management tools and consoles. OpenManage simplifies the lifecycle of deploying, updating, monitoring, and maintaining your Dell PowerEdge servers.

iDRAC7 with Lifecycle Controller

The Integrated Dell Remote Access Controller 7 (iDRAC7) with Lifecycle Controller is the heart of the second generation of Dell PowerEdge server embedded management functionality. In addition to enabling agent-free management, iDRAC7 with Lifecycle Controller provides remote access to the system—whether or not there is a functioning operating system running on the server. These embedded features improve all aspects of a typical server lifecycle. Table 22 describes the functions and benefits of iDRAC7 with Lifecycle Controller.

Table 22. iDRAC7 with Lifecycle Controller functions and benefits

Feature	Function	Benefit
Out of band (OOB)	iDRAC7 offers real-time OOB discovery, inventory, deployment monitoring, alerting and updates for servers and internal storage	Manage servers independent of the OS type or status—even if an OS is not installed
Single code base	All server types have the same embedded management hardware and firmware	Simplified and consistent maintenance across server platforms
Dedicated GigE port (PowerEdge rack and tower systems)	Gigabit Ethernet replaces 10/100 on predecessor iDRAC6	Fast throughput for better performance; compatibility with setup for switches
Email alerts	Simplified, more informative, and expanded coverage than previous versions of iDRAC	More detail allows IT administrators to be more efficient in diagnosing and remediating an issue; alerts include a direct, embedded URL in the email notification to further speed resolution
vFlash media	Enabled with iDRAC7 Enterprise	Allows for use of a non-Dell SD card
Enhanced power management	Integration with Intel Node Manager provides data center level power monitoring and capping (requires iDRAC7 Enterprise)	Fine tune data center power policies, capping, and usage; report on historical power usage by rack, row or room using Power Center Manager (new)



Feature	Function	Benefit
Electronic licensing	Upgrades to iDRAC7 Express or iDRAC7 Enterprise by software licensing key and license portal (may require installation of hardware option for 200-500 series servers)	<p>If iDRAC7 Express or iDRAC7 Enterprise is ordered during initial point of sale, license key is installed. If Basic Management is ordered during initial point of sale, customer must request a license key through the Dell Licensing Portal.</p> <p>For most server models, embedded server management and electronic licensing enables feature enhancements that do not require installation of additional hardware or system downtime.</p>

Feature comparison

The systems management default for the T420 is basic management with an upgrade option for iDRAC7 Express or iDRAC7 Enterprise. A detailed feature comparison of basic management, iDRAC7 Express, and iDRAC7 Enterprise is shown in Table 23.

Table 23. Feature comparison for basic management, iDRAC7 Express, and iDRAC7 Enterprise

Feature (function)	Basic management	iDRAC7 Express	iDRAC7 Enterprise
Local configuration with Lifecycle Controller GUI	•	•	•
IPMI 2.0	•	•	•
Embedded diagnostics	•	•	•
Local OS install	•	•	•
Local updates	•	•	•
Driver pack	•	•	•
Shared NIC (LOM) ¹	•	•	•
Remote update	• ²	•	•
Power control	• ²	•	•
Power monitoring		•	•
Encryption		•	•
IPv6		•	•
Auto-discovery		•	•
Auto-recovery		•	•
Web GUI		•	•



Feature (function)	Basic management	iDRAC7 Express	iDRAC7 Enterprise
Remote CLI		•	•
Local/SSH CLI		•	•
Serial redirection		•	•
Remote config		•	•
Email alerts		•	•
SNMP alerts		•	•
Comprehensive monitoring		•	•
Crash screen capture ³		•	•
Dedicated NIC 1Gbps (100MB in iDRAC6)			• ⁴
Part replacement			•
Backup and restore configurations			•
Virtual console (4 user)			•
Virtual console chat			•
Support for customer supplied SD cards for vFlash media			•
Virtual flash partitions			•
Virtual media			•
Virtual folders			•
Remote file share			•
Crash video playback			•
Boot record/playback			•
Power capping			•
Enterprise group power management			•
Directory services (AD, LDAP)			•
PK authentication			•
Two-factor authentication ⁴			•

¹Rack and tower systems only

²Feature available with IPMI, not web GUI

³Requires OMSA agent on target server

⁴Uses Microsoft® ActiveX® on Internet Explorer® only



Agent-based management

Most systems management solutions require pieces of software, called agents, to be installed on each node in order to be managed within the IT environment. Additionally, the same agent is often used as a local interface into the hardware health and may be accessed remotely as a management interface, typically referred to as a one-to-one interface. For customers that continue to use agent-based solutions, Dell provides OpenManage Server Administrator.

OpenManage Server Administrator

The Dell OpenManage Server Administrator (OMSA) agent gives you a comprehensive, one-to-one systems management solution for both local and remote servers and their storage. OMSA can help simplify single-server monitoring with a secure command-line interface (CLI) or Web-based management graphical user interface (GUI). It can also be used to view system configuration, inventory, health, and performance.

Agent-free management

Because Dell PowerEdge servers have embedded server lifecycle management, in many cases, there is no need to install an OpenManage systems management software agent into the operating system of a Dell PowerEdge server. This greatly simplifies and streamlines the management footprint.

Dell consoles

The central console in a systems management solution is often referred to as the one-to-many console. The central console provides a rapid view and insight into the overall health of all systems in the IT environment. The Dell systems management portfolio includes several powerful consoles, depending upon your needs, including the following:

- **Dell OpenManage Essentials**— OpenManage Essentials (OME) is a recently released systems management console that provides a comprehensive view of Dell systems, devices, and components in an enterprise network. It is used to monitor Dell PowerEdge servers, EqualLogic™ and PowerVault™ storage, and PowerConnect™ switches; to update and configure Dell servers; and to create asset reports. OpenManage Essentials also communicates health status alerts for Dell servers, storage, and network devices to the Dell KACE™ K1000 service desk. OpenManage Essentials is available as a no-charge software download from Support.Dell.com.
- **Dell Management Console**—Dell Management Console (DMC) offers sophisticated data center management capabilities with comprehensive reporting features. DMC can perform basic hardware management and can manage operating systems and applications using various plug-ins from Symantec.
- **Dell IT Assistant**—Dell IT Assistant (ITA) is a console for managing Dell servers, storage arrays, and other components distributed throughout a network. Dell IT Assistant allows for easy identification of system issues through alerts, helping to reduce system downtime. Systems administrators can easily monitor systems anywhere within their network using ITA. ITA is supported on the T420, however, enhanced functionality is now available with OpenManage Essentials.

OpenManage systems management tools and utilities

Dell OpenManage systems management tools and utilities consist of the following:

- **Dell Repository Manager**—The Dell Repository Manager (RM) is a standalone GUI-based productivity tool that helps simplify the process of managing downloads and baseline BIOS, firmware, and driver updates. Repository Manager can create deployment disks as well as create and manage customized repositories.



- **Dell OpenManage Server Update Utility**—The Dell Server Update Utility (SUU) is a DVD-based application for identifying and applying BIOS and firmware updates to your Dell PowerEdge servers.
- **Dell OpenManage Systems Build and Update Utility**—The Dell System Build and Update Utility (SBUU) provides one-to-one and one-to-many deployment and single-server update capabilities in the pre-operating system environment.
- **Dell Update Packages**—The Dell Update Packages (DUP) is a self-contained executable in a standard package format that updates a software element on a Dell server such as the BIOS, a driver, firmware and other software updates.
- **Dell OpenManage Deployment Toolkit**—The Dell OpenManage Deployment Toolkit (DTK) is a CLI-based tool that includes a set of utilities for configuring and deploying Dell PowerEdge systems, and can be used to build scripted, unattended OS installations to deploy large numbers of servers in a reliable fashion.
- **RACADM**—The RACADM command-line utility provides a scriptable interface that allows you to locally or remotely configure iDRAC7.
- **IPMITool**—IPMITool includes scriptable console application programs used to control and manage remote systems using the IPMI version 1.5 and later protocol.

Integration with third-party consoles

Dell OpenManage easily integrates with several leading third-party consoles, including:

- **Dell Server Management Pack Suite for Microsoft System Center Operations Manager (SCOM)**—This suite of server management packs enables several functions through System Center Operations Manager, including in-band discovery and monitoring of racks and towers, out-of-band discovery and monitoring through iDRAC with Lifecycle Controller, as well as performance and advanced monitoring.
- **Dell Lifecycle Controller Integration (DLCI) for Microsoft System Center Configuration Manager (SCCM)**—This pack contains Dell Lifecycle Controller Integration (DLCI), which integrates OpenManage functions in SCCM to manage the Dell PowerEdge servers, including auto-discovery, operating system deployment and configuration of hardware elements, (RAID, NIC, BIOS, iDRAC), OS and hypervisor agnostic updates, firmware management, and system viewer utilities.
- **Dell Server PRO Management Pack for Microsoft System Center Virtual Machine Manager (SCVMM)**—This pack manages Dell physical servers and hosts of virtual machines (VMs) by using Microsoft System Center Operations Manager/System Center Essentials (SCOM/SCE) and System Center Virtual Machine Manager (SCVMM). It provides guidance for remedial actions based on alerts to best manage virtual machines and handle the impacts appropriately.
- **Dell Management Plug-in for VMware vCenter**—This plug-in allows IT administrators to monitor, provision, and manage the physical PowerEdge server hardware and firmware from a dedicated Dell menu accessed through the VMware vCenter console using the same role-based access control model as vCenter, combining physical server management.
- **BMC Software**—Dell and BMC Software work together to simplify IT by ensuring tight integration between Dell server, storage, and network management functionality and the BMC Software process and data center automation products.



OpenManage connections with third-party consoles

Dell OpenManage provides connections with many third-party consoles, including:

- **Dell OpenManage Connection for Computer Associates Network and Systems Management**—This connection allows you to monitor PowerEdge servers and PowerVault storage arrays from within the Computer Associates Network and Systems Management (CA NSM) console.
- **Dell OpenManage Connection for HP Operations Manager**—This connection enables several functions through HP Operations Manager, including auto-grouping, SNMP trap reception, global health monitoring, and a context-sensitive launch of OpenManage Server Administrator.
- **Dell OpenManage Connection for IBM Tivoli Netcool/OMNIBus**—This connection provides event monitoring capabilities to monitor Dell PowerEdge servers and Dell EqualLogic systems. It allows event monitoring, automatic event correlation, and launching device consoles from the Netcool/OMNIBus console.

Dell server management operations

Dell OpenManage systems management is centered on automating the server management lifecycle—deploy, update, monitor, and maintain. To manage an infrastructure properly and efficiently, you must perform all of these functions easily and quickly. iDRAC7 with Lifecycle Controller technology provides you with these intelligent capabilities embedded within the server infrastructure. This allows you to invest more time and energy on business improvements and less on maintenance. Figure 11 illustrates the various operations that can be performed during the server's lifecycle.

Figure 11. Systems management server lifecycle



Table 24 lists the products that are available for one-to-one and one-to-many operations, and when they are used in the server's lifecycle:

Table 24. One-to-one and one-to-many operations

Operation	One-to-one	One-to-many	
Deploy	<ul style="list-style-type: none"> • Lifecycle Controller GUI • DTK • SBUU 	<ul style="list-style-type: none"> • Symantec Deployment Server • Dell Management Plug-in for VMware vCenter • KACE K1000 Appliance • Lifecycle Controller Remote Services • BMC BladeLogic integration with Lifecycle Controller 	<ul style="list-style-type: none"> • Dell Server Deployment Pack (DSDP) for Microsoft System Center Configuration Manager and Dell Lifecycle Controller Integration (DLCI) for Microsoft System Center Configuration Manager
Update	<ul style="list-style-type: none"> • iDRAC7 with LifeCycle Controller • Lifecycle Controller GUI • Repository Manager • DUP • SUU • SBUU • Dell Management Plug-in for VMware vCenter 	<ul style="list-style-type: none"> • Dell OpenManage Essentials • Dell OpenManage ITA • Dell Management Console • Lifecycle Controller Remote Services 	<ul style="list-style-type: none"> • Dell Update Catalogs for Microsoft System Center Configuration Manager • Dell Lifecycle Controller Integration (DLCI) for Microsoft System Center Configuration Manager
Monitor	<ul style="list-style-type: none"> • iDRAC7 • OMSA 	<ul style="list-style-type: none"> • Dell OpenManage Essentials • Dell OpenManage ITA • BMC ProactiveNet Performance Management • Dell OpenManage Power Center • Dell Management Console 	<ul style="list-style-type: none"> • Dell Management Plug-in for VMware vCenter • BMC ProactiveNet • Dell Server Management Pack Suite for Microsoft System Center Operations Manager (SCOM)
Maintain	<ul style="list-style-type: none"> • IPMI • iDRAC7 • Lifecycle Controller GUI 	<ul style="list-style-type: none"> • Lifecycle Controller Remote Services 	<p>Remediate:</p> <ul style="list-style-type: none"> • Dell Server PRO Management Pack for Microsoft System Center Virtual Machine Manager (SCVMM) <p>Replace parts:</p> <ul style="list-style-type: none"> • Dell Lifecycle Controller Integration (DLCI) for Microsoft System Center Configuration Manager

For additional detailed information on Dell's systems management portfolio, see the *Dell Systems Management Overview Guide* on Support.Dell.com/Manuals.



Appendix A. Additional specifications

Chassis dimensions and weight

Figure 12 details the dimensions of the Dell PowerEdge T420 chassis.

Figure 12. Tower and rack chassis dimensions

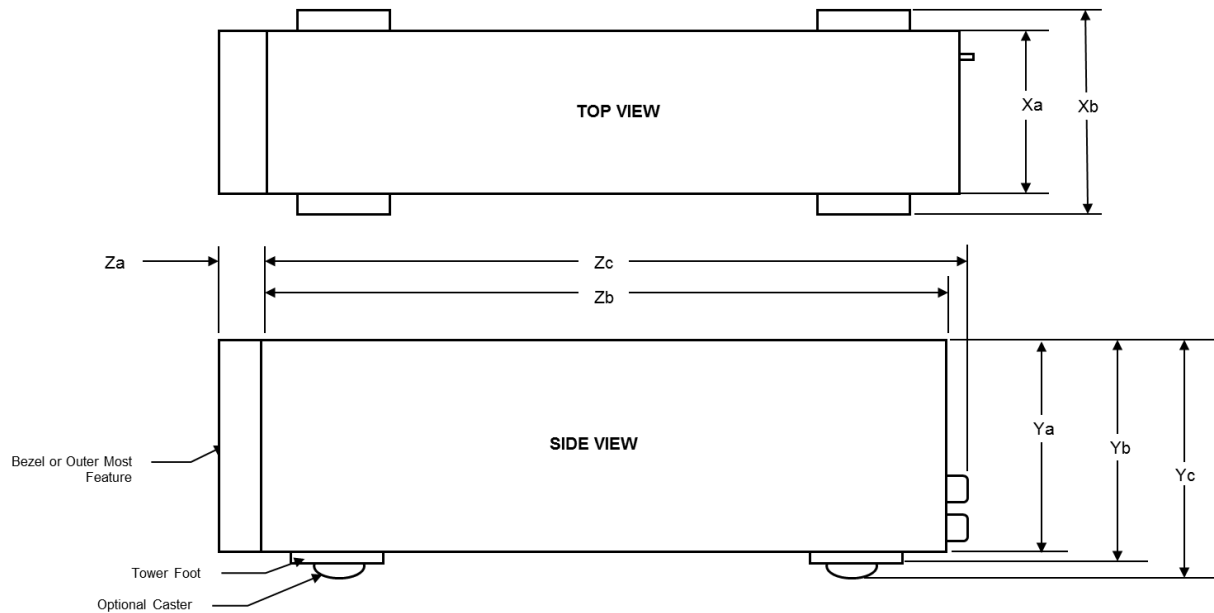

Xa	Xb	Ya	Yb	Yc	Za with bezel	Za without bezel	Zb ¹	Zc
218.0mm	304.5mm (foot) 307.9mm (caster)	430.3mm	443.3mm	471.3mm	16.4mm	0.0mm	542.2mm	578.42mm

¹Zb goes to the nominal back wall external surface where the I/O connectors reside.

The maximum system weight for the T420 is 30.2 kg (66.57 lb).

Power supply specifications

Table 25 lists power supply specifications for the PowerEdge T420.

Table 25. Power supply specifications

Specification	Redundant 1100W	Redundant 750W	Redundant 495W	Non-redundant 550W
Current consumption	12A–6.5A	10A–5A	6.5A–3A	7.4A–3.7A
Supply voltage	100–240VAC ¹	100–240VAC ¹	100–240VAC ¹	100–240VAC ¹
Frequency	50/60Hz	50/60Hz	50/60Hz	50/60Hz
Heat dissipation (BTU/hr max)	4100	2891	1908	2317

¹Auto-ranging



Environmental specifications

Table 26 details the environmental specifications for the T420. For additional information about environmental measurements for specific system configurations, see Dell.com/environmental_datasheets.

Table 26. Environmental specifications

Fresh Air: temperature, humidity, altitude de-rating	
Continuous operation	10°C to 35°C (50°F to 95°F) at 10% to 80% relative humidity with 26°C (78.8°F) maximum dew point (maximum wet bulb temperature). De-rate maximum allowable dry bulb temperature at 1°C per 300m above 950m (1°F per 547 ft above 3117 ft).
Expanded operation	<p>When operating in the expanded temperature range, system performance may be impacted, and ambient temperature warnings may be reported on the LCD and in the System Event Log.</p> <p>≤ 10% of annual operating hours: 5°C to 10°C and 35°C to 40°C (with no direct sunlight on the equipment) at 5% to 85% relative humidity with 26°C dew point (maximum wet bulb temperature). Outside the standard operating temperature (10°C to 35°C), the system can operate down to 5°C or up to 40°C for a maximum of 10% of its annual operating hours. For temperatures between 35°C and 40°C (95°F to 104°F), de-rate maximum allowable dry bulb temperature by 1°C per 175m above 950m (1°F per 319 ft above 3117 ft).</p> <p>≤ 1% of annual operating hours: -5°C to 5°C and 40°C to 45°C (with no direct sunlight on the equipment) at 5% to 90% relative humidity with 26°C dew point (maximum wet bulb temperature). Outside the standard operating temperature (10°C to 35°C), the system can operate down to -5°C or up to 45°C for a maximum of 1% of its annual operating hours. For temperatures between 40°C and 45°C (104°F to 113°F), de-rate maximum allowable dry bulb temperature by 1°C per 125m above 950m (1°F per 228 ft above 3117 ft).</p> <p>Expanded operation restrictions:</p> <ul style="list-style-type: none"> • No cold startup below 5°C • Maximum altitude for the operating temperature must be 3050m (10,000ft) • Up to two redundant fans (back fans required) • Redundant PSU configuration required • Not supported: <ul style="list-style-type: none"> – GPU – LRDIMM – Peripheral cards not qualified by Dell – Peripheral cards greater than 25W
Temperature	
Operating	See Fresh Air for temperature information
Storage	-40°C to 65°C (-40°F to 149°F) with a maximum temperature gradation of 20°C per hour
Relative humidity	
Operating	See Fresh Air for relative humidity information
Storage	5% to 95% at a maximum wet bulb temperature of 33°C (91°F); atmosphere must be condensing at all times
Maximum vibration	
Operating	0.26 Grms at 5Hz to 350Hz in all orientations
Storage	1.87 Grms at 10Hz to 500Hz for 15 minutes (all six sides tested)



Maximum shock

Operating	Half sine shock in all operational orientations of 31G +/- 5% with a pulse duration of 2.6ms +/- 10%
Storage	Half sine shock on all six sides of 71G +/- 5% with a pulse duration of 2ms +/- 10%; square wave shock on all six sides of 27G with velocity change at 235 in/sec or greater

Altitude

Operating	-15.2m to 3048m (-50 ft to 10,000 ft)
Storage	-15.2m to 12,000m (-50 ft to 39,370 ft)

Airborne contaminant level

Class G1 or lower as defined by ISA-S71.04-1985

Video specifications

The Dell PowerEdge T420 iDRAC incorporates an integrated video subsystem. The graphics controller is the 2D Matrox® G200. The video frame buffer (16MB) is contained within the iDRAC RAM (256MB) device.

The T420 system supports the 2D graphics video modes listed in Table 27 and Table 28.

Table 27. Supported video modes for back VGA port

Resolution	Refresh Rate (Hz)	Color Depth (bit)
640 x 480	60, 70	8, 16, 32
800 x 600	60, 75	8, 16, 32
1024 x 768	60, 75	8, 16, 32
1152 x 864	60, 75	8, 16, 32
1280 x 1024	60	8, 16, 32

Table 28. Supported video modes for front VGA port

Resolution	Refresh Rate (Hz)	Color Depth (bit)
640 x 480	60, 70	8, 16, 32
800 x 600	60, 75	8, 16, 32
1024 x 768	60	8, 16, 32

Rack rail specifications

Table 29 lists the spacing dimensions for the T420 sliding rails.



Table 29. Rail adjustability range

Product	Rail identifier	Rail type	Rail adjustability range (mm)						Rail depth (mm)	
			Square		Round		Threaded		without CMA	with CMA
			Min	Max	Min	Max	Min	Max		
T420	C2	Sliding	686	756	672	749	686	771	760	840

The adjustment range of the rails is a function of the type of rack in which they are being mounted. The min-max values listed above represent the allowable distance between the front and rear mounting flanges in the rack. Rail depth without the CMA represents the minimum depth of the rails with the outer CMA brackets removed (if applicable) as measured from the front mounting flanges of the rack.

USB peripherals

USB peripherals are supported through the front and back USB ports on the T420. These ports are USB 2.0 compliant.



Appendix B. Standards compliance

The Dell PowerEdge T420 conforms to the industry standards listed in Table 30.

Table 30. Industry standard documents

Standard	URL for information and specifications
ACPI Advance Configuration and Power Interface Specification, v2.0c	www.acpi.info
Ethernet IEEE 802.3-2005	standards.ieee.org/getieee802/802.3.html
HDG Hardware Design Guide Version 3.0 for Microsoft Windows Server	www.microsoft.com/whdc/system/platform/pcdesign/desguide/serverdg.msp
IPMI Intelligent Platform Management Interface, v2.0	www.intel.com/design/servers/ipmi
DDR3 Memory DDR3 SDRAM Specification, Rev. 3A	www.jedec.org/download/search/JESD79-3C.pdf
LPC Low Pin Count Interface Specification, Rev. 1.1	developer.intel.com/design/chipsets/industry/lpc.htm
PCI Express PCI Express Base Specification Rev. 2.0 and 3.0	www.pcisig.com/specifications/pciexpress/
PMBus Power System Management Protocol Specification, v1.2	pmbus.info/specs.html
SAS Serial Attached SCSI, v1.1	www.t10.org
SATA Serial ATA Rev. 2.6; SATA II, SATA 1.0a Extensions, Rev. 1.2	www.sata-io.org
SMBIOS System Management BIOS Reference Specification, v2.7	www.dmtf.org/standards/smbios
TPM Trusted Platform Module Specification, v1.2	www.trustedcomputinggroup.org
UEFI Unified Extensible Firmware Interface Specification, v2.1	www.uefi.org/specs
USB Universal Serial Bus Specification, Rev. 2.0	www.usb.org/developers/docs
Windows Logo Windows Logo Program System and Device Requirements, v3.10	www.microsoft.com/whdc/winlogo/hwrequirements.msp



Appendix C. Additional resources

Table 31 provides a list of documents and websites that provide for more information on the Dell PowerEdge T420.

Table 31. Additional resources

Resource	Description of contents	Location
PowerEdge T420 Systems Owner's Manual	<p>This manual is provided in HTML format on the CD provided with the T420 system, and also in HTML and PDF format at the Dell support site. A printed version is available in Asian languages as a customer-orderable option. This manual provides information on the following:</p> <ul style="list-style-type: none">• Chassis features• System Setup program• System messages• System codes and indicators• System BIOS• Remove and replace procedures• Troubleshooting• Diagnostics• Jumpers and connectors	Support.Dell.com/Manuals
PowerEdge T420 Getting Started Guide	<p>This guide is printed and shipped with the system, and is also available in PDF format on the Dell support site. This guide provides information on the following:</p> <ul style="list-style-type: none">• Initial setup steps• Key system features• Technical specifications	Support.Dell.com/Manuals
Rack Installation Instructions	<p>This printed document is provided with the rack kits. The document provides the instructions for installing the server in a rack.</p>	Support.Dell.com/Manuals
Cable Management Arm Installation Instructions	<p>This printed document is provided with the CMA kits. The document provides the instructions for installing the cable management arm on the rails.</p>	Support.Dell.com/Manuals
Information Update	<p>This document is printed and shipped with the system, and is also available in PDF format on the Dell support site. This document provides information on system updates.</p>	Support.Dell.com/Manuals
System Information Label	<p>The system information label documents the system board layout and system jumper settings. Text is minimized due to space limitations and translation considerations. The label size is standardized across platforms.</p>	Inside the system chassis cover



Resource	Description of contents	Location
Quick Resource Locator (QRL)	This code on the chassis can be scanned by a phone application to access additional information and resources for the server, including videos, reference materials, service tag information, and Dell contact information.	Inside the system chassis cover
Dell Energy Smart Data Center Assessment	This tool uses infrastructure and thermal analysis to help maximize system efficiency.	Dell.com/EnergySmart
Energy Smart Solution Advisor	The Dell Energy Smart Solution Advisor (ESSA) enables easier and more meaningful estimates to help you determine the most efficient configuration possible. Use ESSA to calculate the power consumption of your hardware, power infrastructure, and storage.	Dell.com/ESSA
Power and cooling technologies	Provides details for improving energy efficiency in the data center.	Dell.com/PNC
Energy management	Provides information on Dell's Fresh Air cooling solutions.	Dell.com/FreshAir
Operating system matrix for Dell PowerEdge systems	Provides updated information on which operating systems are available on which PowerEdge systems.	Dell.com/OSsupport
Processor and chipset	Provides more information about the T420 processors and chipset.	Intel.com
Dell PowerEdge RAID controllers	Provides more information about Dell PERCs.	Dell.com/PERC
Power distribution unit	Provides help selecting a rack-based power distribution unit.	DellPDU.com
Uninterruptible power supply	Provides help selecting an uninterruptible power supply model.	DellUPS.com
Volatility information	Contact your Dell sales representative.	Dell.com
Dell Enterprise Acoustics	White paper that explores the mechanisms of, people's reaction to, language of, and Dell's work to control noise from Enterprise products.	www.dell.com/downloads/global/products/pedge/en/acoustical-education-dell-enterprise-white-paper.pdf



Appendix D. System board block diagram

Figure 13. T420 system board block diagram

