



PolyGard® AT-1193

Electrochemical Chlorine Transmitter
Serial No. AT03-005

User Manual

October 2011
January 04, 2016 – *Revision*

PolyGard® is a registered trademark of MSR-Electronic GmbH | GAADT531193_E_1011

- 1 Intended Use..... 3**
- 2 Functional Description 3**
 - 2.1 Control Mode..... 3
 - 2.2 Sensor..... 3
- 3 Installation 4**
 - 3.1 Mounting Instructions 4
 - 3.2 Installation..... 4
- 4 Electrical Connection..... 4**
 - 4.1 Wiring Connection..... 5
- 5 Commissioning 5**
 - 5.1 Correction of the Zero-point at the Analog Output Signal..... 5
 - 5.2 Calibration 6
 - 5.2.1 Zero-point 6
 - 5.3.2 Gain 6
 - 5.3.3 Calculation of Control Voltage 6
 - 5.4 Option Relay Output..... 7
- 6 Inspection and Service 7**
 - 6.1 Inspection..... 7
 - 6.2 Service and Calibration 7
 - 6.3 Exchange of Sensor Element..... 8
- 7 Troubleshooting..... 8**
 - 7.1 Analog Mode 8
- 8 Cross-sensitivity Data..... 8**
- 9 Technical Data..... 9**
- 10 Figures 11**
- 11 Part Disposal 13**
- 12 Notes and General Information..... 13**
 - 12.1 Intended Product Application..... 13
 - 12.2 Installers’ Responsibilities 13
 - 12.3 Maintenance 13
 - 12.4 Limited Warranty..... 13

Electrochemical Chlorine Transmitter

1 Intended Use

The PolyGard® Cl analog/digital gas transmitter AT-1193 with digital processing of the measuring values and temperature compensation is used for the continuous monitoring of the ambient air to detect the presence of Chlorine gas. Main application ranges are waterworks, sewage plants, swimming pools etc.

The intended sites are all areas being directly connected to the public low voltage supply, e.g. residential, commercial and industrial ranges as well as small enterprises (according to EN50 082).

The PolyGard® Cl₂ analog/digital transmitter must not be used in potentially explosive atmospheres. The transmitter must only be employed in areas within the environmental conditions as specified in the Technical Data.

2 Functional Description

2.1 Control Mode

The analog output can be selected as current signal with (0)4-20 mA or as voltage signal (0)2-10 V. In the 4-20 mA mode and without any supplementary options, the AT-1193 also works in the 2-wire technique.

2.2 Sensor

The sensor portion of the transmitter is a sealed electro-chemical cell with three electrodes, sensing, counter and reference. The ambient air to be monitored diffuses through a membrane filter into the liquid electrolyte of the sensor. The chemical process of the measurement is one of reduction where one molecule of the target gas is exchanged for one molecule of oxygen. The reaction drives the oxygen molecule to the counter electrode, generating a DC microampere signal between the sensing and reference electrodes. This signal is linear to the volume concentration of the sensed gas. The signal is evaluated by the connected amplifier and transformed into a linear output signal.

Electrochemical processes always lead by and by to a loss of sensitivity. Therefore regular calibration of zero- point and gain is obligatory. See also section 6.

Caution:

There is a small quantity of corrosive liquid in the sensor element. If in case of damage persons or objects touch the liquid, you have to clean the affected areas as fast and carefully as possible with tap water. Out of use sensors must be disposed in the same way as batteries.

3 Installation

Note: Avoid any force (e.g. by thumb) on the sensor element during operation or installation. Electronics can be destroyed by static electricity. Therefore, do not touch the equipment without a wrist strap connected to ground or without standing on a conductive floor (acc. to DIN EN100015).

3.1 Mounting Instructions

When choosing the mounting site please pay attention to the following:

- The specific weight of Chlorine Cl_2 is higher than that of air (factor 2.4).
Recommended mounting height is 0.2 m (0.7 ft.) to 0.3 m (1 ft.) above floor.
- Choose mounting location of the sensor according to the local regulations.
- Consider the ventilation conditions. Do not mount the transmitter in the center of the airflow (air passages, suction holes).
- Mount the transmitter at a location with minimum vibration and minimum variation in temperature (avoid direct sunlight).
- Avoid locations where water, oil etc. may influence proper operation and where mechanical damage might be possible.
- Provide adequate space around the sensor for maintenance and calibration work.

Duct mounting

- Mount only in a straight section of duct with minimum air vortex. Keep a minimum distance of 1 m (3.5 feet) from any curve or obstacle.
- Mount only in a duct system with a maximum air velocity of 10 m/s (2000 ft/min) or less.
- Mounting must be performed so that the probe openings are in line with the airflow.

3.2 Installation

- Open the cover. Unplug basic PCB carefully from the bottom part.
- Fix bottom part by screws vertically to the wall (terminal blocks to the ground).
- Replug the basic PCB at X4 and X5 with care. Replace the cover.

4 Electrical Connection

Consider static electricity See 3. Mounting

- Installation of the electrical wiring should only be executed by a trained specialist according to the connection diagram, without any power applied to conductors and according to the corresponding regulations
- Avoid any influence of external interference by using shielded cables for the signal line, but do not connect the shield.
- Recommended cable for analog mode: J-Y(St)Y 2x2x0.8 LG (20 AWG), max. loop resistance 73 Ω /km (20.8 Ω /1000 ft).
- It is important to ensure that the wire shields or any bare wires do not short the mounted PCB.

4.1 Wiring Connection

- Open the cover. Unplug basic PCB carefully from terminal blocks X4 and X5.
- Insert the cable and connect cable leads to terminal blocks. See fig. 1.
- Replug the PCB in the terminal blocks X4, X5 with care. Replace the cover.

Note: The connection of the power supply at the output signal (X4 pin 4) can destroy the transmitter.

5 Commissioning

Consider commissioning instructions at any exchange of the sensor element as well.

Only trained technicians should perform the following:

- Check mounting location.
- Select output signal form: Current or voltage, and starting point 0 or 20%. See fig. 4.
- Check power voltage.
- Check PCB AT03 for correct mounting at X4 and X5.

Required instruments for commissioning (calibration) of the transmitter:

- Test gas bottle with synthetic air (20 % O₂, 80 % N) or chlorine-free ambient air.
- Test gas bottle with Cl₂ (ppm) in the range of 30 – 70 % of the measuring range. Rest is synthetic air.
- Gas pressure regulator with flow meter to control the gas flow to 150 ml/min.
- Calibration adapter with tube. Calibration set CONKIT-E/CH-AT. See fig. 5.
- Digital voltmeter with range 0 – 300 mV, accuracy 1%.
- Small screwdriver.

Note:

Prior to calibration the sensor must be connected to the power supply and fully stabilized for at least 6 hours without interruption.

Please observe proper handling procedures for test gas bottles!

Attention: CL₂ calibration gas is toxic, never inhale the gas
Symptoms: Chemical burn, dizziness, headache and nausea.
Procedure if exposed: Take the victim into fresh air at once, call a doctor.

5.1 Correction of the Zero-point at the Analog Output Signal

The analog output signal is factory set to the zero-point. If necessary, a manual adaptation of the analog signal is possible within 10 sec. after having applied the supply voltage.

- Jumper 0-20 % for signal start has to be set (= 4 mA or 2 V).
- Connect digital voltmeter (300 mV) at test pint "Test" (measuring signal ~ 40 mV = 4.0 mA).
- Switch on the operating voltage.
- Each pressing on the "Zero" push-button increases the signal by + 0.5 mV (0.05 mA). Press the button repeatedly until the measuring signal reaches 40 ± 0.2 mV. After 44mV the signal starts again at 36 mV. The correction is only possible within the 10 seconds after having switched on the power supply. An impulse pause of more than 10 sec. cancels the release of the correction function.

5.2 Calibration

Manual calibration is only possible if the transmitter is equipped with the push-button “Zero” and the potentiometer “Gain” (= version for manual calibration).

5.2.1 Zero-point

- Connect digital voltmeter to pin “Test”.
- Connect calibration adapter carefully to the sensor element.
- Apply synthetic air (150 ml/min; 1 Bar (14.5 psi) ± 10%), or Chlorine (Cl₂)-free ambient air.
- Wait 2 minutes until the signal is stable, push button “Zero” for 5 seconds.

After successful calibration the measuring signal is corrected automatically. Depending on the selected signal starting point the measuring signal shows the following values:

Signal start at 2 V or 4 mA 40 mV = 0 ppm
 Signal start at 0 V or 0 mA 0 mV = 0 ppm

If the zero-point is out of the admissible range (> 20 mV at starting point 0% / > 60 mV at starting point 20%) before calibration, there is no correction of the measuring signal. The sensor has to be replaced.

- Remove calibration adapter carefully by turning lightly. Check the sensor for correct mounting

5.3.2 Gain

- Connect digital voltmeter to pin “Test”.
- Connect calibration adapter carefully to the sensor element.
- Apply calibration test gas Cl₂ (150 ml/min; 1 Bar (14.5 psi) ± 10%).
- Wait three minutes until the signal is stable, adjust control voltage with potentiometer “Gain” until the signal corresponds to the calculated value ± 2 mV, see “5.3.3 Calculation of Control Voltage”.
- Remove calibration adapter with a careful light turn. Check the sensor for correct mounting

By limiting the gain factor, calibration will not be possible any more when the sensitivity of the sensor reaches a residual sensitivity of 30 %. Then the sensor has to be replaced.

5.3.3 Calculation of Control Voltage

Signal start 2 V / 4 mA

$$\text{Control voltage (mV)} = \frac{160 \text{ (mV)} \times \text{test gas concentration Cl}_2 \text{ (ppm)}}{\text{measuring range Cl}_2 \text{ (ppm)}} + 40 \text{ (mV)}$$

Signal start 0 V / 0 mA

$$\text{Control voltage (mV)} = \frac{200 \text{ (mV)} \times \text{test gas concentration Cl}_2 \text{ (ppm)}}{\text{measuring range Cl}_2 \text{ (ppm)}}$$

Example:

| | |
|--|------------------------|
| Measuring range | 20 ppm |
| Test gas concentration | 10 ppm Cl ₂ |
| Control voltage: Signal start 2 V / 4 mA | 120 mV |
| Control voltage: Signal start 0 V / 0 mA | 100 mV |

Signal start 2 V / 4 mA

$$\frac{160 \text{ (mV)} \times 10 \text{ (ppm)}}{\text{mV } 20 \text{ (ppm)}} + 40 \text{ (mV)} = 120 \text{ mV}$$

Signal start 0 V / 0 mA

$$\frac{200 \text{ (mV)} \times 10 \text{ (ppm)}}{20 \text{ (ppm)}} = 100$$

5.4 Option Relay Output

The two relays are activated in dependence of the gas concentration. If the gas concentration exceeds the adjusted alarm threshold, the corresponding relay switches on. If the gas concentration falls below the threshold minus hysteresis, the relay switches off again.

The contact function for relay 2, NC (normally closed) or NO (normally open), can be selected via the jumper NO/NC. See fig 1 and 3. Relay 1 is equipped with a change-over contact.

Via the ModBus interface the two alarm thresholds and the hysteresis are freely adjustable at the PC within the measuring range. The procedure can be read from the user manual "ModBus Software".

The following parameters are factory-set.

Alarm threshold 1 = Relay 1: 5 ppm

Alarm threshold 2 = Relay 2: 8 ppm

Switching hysteresis: 1 ppm

6 Inspection and Service

Inspection, service and calibration of the transmitters should be done by trained technicians and executed at regular intervals. We therefore recommend concluding a service contract with INTEC Controls or one of their authorized partners.

According to EN 45544-4, inspection and service has to be executed at regular intervals. The maximum intervals have to be determined by the person responsible for the gas warning system according to the legal requirements. INTEC Controls recommends checking the PolyGard Transmitter every three months and maintaining it every 12 months. If different intervals are indicated, always consider the shortest interval.

Inspections and services must be documented. The date for the next maintenance has to be affixed to the transmitter.

6.1 Inspection

The PolyGard Transmitter should be checked regularly by a competent person. The following has to be checked in particular:

- Maintenance/ calibration interval not exceeded.
- Visual inspection of the transmitter including cable for damage etc.
- Remove dust deposits, especially at the gas inlet.

6.2 Service and Calibration

When performing the maintenance you have to do the calibration and the functional test in addition to the inspection.

- Calibration: See section 5.
- Functional test: Check the output signal at the test pins during calibration.

6.3 Exchange of Sensor Element

Consider static electricity See point 3.

Sensor should always be installed without power applied:

- Unplug basic PCB AT03 carefully from the bottom part.
- Unplug old sensor element from the PCB.
- Take the new sensor out of the original packing.
- Plug the sensor element in the PCB.
- Replug the PCB AT03 in the terminal blocks X4, X5 carefully.
- Calibrate according to section 5.

7 Troubleshooting

7.1 Analog Mode

| Trouble | Cause | Solution |
|--|--|--|
| Output signal < 3 mA / 1,5 V and/or control voltage < 30 mV only for starting signal 2V/4 mA | Jumper 0-20 % not set | Check jumper position |
| | Power voltage not applied | Measure tension at X4: Two-wire: Pin 1 (+) and 4 (-) Three-wire: Pin 1 (+) and 2 (-) |
| | PCB AT03 not plugged in correctly at X4 and X5 | Replug PCB correctly |
| | Wire break | Check the wiring |
| Output signal > 22 mA /220 mV | Short-circuit | Check the wiring |
| Control voltage does not reach the calculated value | Sensor element not calibrated | Calibrate sensor element |
| | Sensor sensitivity < 30 % | Replace sensor element |
| No reaction of the output signal in spite of gas concentration | Power voltage not applied | Measure tension at X4 |
| | Signal (Pin 4) not wired correctly | Check the wiring |

8 Cross-sensitivity Data

The cross sensitivity can be read from the table Technical Data (see section 9). The table doesn't claim to be complete. Other gases can have an influence on the sensitivity, too. The indicated sensitivity data are only standard values referring to new sensor elements.

9 Technical Data

| | | |
|--|---|---------------------------------|
| General sensor performances | | |
| Gas type | Chlorine (Cl ₂) | |
| Sensor element | Electrochemical, diffusion | |
| Measuring range | 0 - 10 ppm (factory set) 0 – 20 ppm (optional) | |
| Temperature range | - 10 °C to + 45 °C (14 °F to 113 °F) | |
| Pressure range | Atmosphere ± 15 % | |
| Humidity | 15 – 95 % RH non condensing | |
| Storage temperature range | 5 °C to 30 °C (41 °F to 86 °F) | |
| Storage time | Max. 6 months | |
| Mounting height | 0.2m (0.7ft.) | |
| Stability & resolution | ± 0,1 ppm | |
| Repeatability | ± 2 % of reading | |
| Long-term output drift | < 2% signal loss/year | |
| Response time | t ₉₀ < 90 sec. | |
| Life expectancy | > 2 years/normal operating environment | |
| Cross sensitivity ¹ | Concentration (ppm) | Reaction (ppm Cl ₂) |
| Carbon monoxide, CO | 300 | |
| Hydrogen, H ₂ | 300 | 0 |
| Nitrogen dioxide, NO ₂ | 20 | ~ 20 |
| Nitrogen monoxide, NO | 35 | 0 |
| Sulphur dioxide, SO ₂ | 5 | |
| Electrical | | |
| Power supply | 18 - 28 VDC/AC, reverse polarity protected (2-wire mode only VDC) | |
| Power consumption (without options) - Analog mode | 22 mA, max. (0.6 VA) | |
| Output signal | | |
| Analog output signal Selectable: Current / tension Starting point 0 / 20 % | (0) 4 – 20 mA, load ≤ 500 Ω, (0) 2 - 10 V; load ≥ 50 k Ω proportional, overload and short-circuit proof | |

¹ The table doesn't claim to be complete. Other gases, too, can have an influence on the sensitivity. The mentioned cross sensitivity data are only reference values valid for new sensors.

| | |
|---|---|
| Physical | |
| Enclosure stainless steel Type 5 | Stainless steel V2A |
| Enclosure colour | Natural, brushed |
| Dimensions (W x H x D) | 113 x 135 x 45 mm (5.35 x 4.5 x 1.8 in.) |
| Weight | Approx. 0.5 kg (1.1 lb.) |
| Protection class | IP55 |
| Mounting | Wall mounting, pillar mounting |
| Enclosure Plastic, Type A | Polycarbonate |
| Flammability | UL 94 V2 |
| Enclosure colour | Light grey RAL 7032 |
| Dimensions (W x H x D) | 94 x 130 x 57 mm (3.7 x 5.12 x 2.24 in.) |
| Weight | Approx. 0.3 kg (0.6 lb.) |
| Protection class | IP 65 |
| Mounting | Wall mounting |
| Cable entry | Standard 1 x M 20 |
| Wire connection | Screw-type terminal: 0.25 to 2.5 mm ² 24 to 14 AWG |
| Wire distance | Current signal ca. 500 m (1500 ft.) Voltage signal ca. 200 m (500 ft.) |
| Guidelines | EMC Directive 2004 / 108 / EEC |
| | CE |
| Approvals | |
| Enclosure Type A | UL 508A |
| Warranty | Two years material and workmanship, 12 months normal exposure for sensor element |
| Options | |
| Relay output | |
| Alarm relay 1 (switching threshold 5 ppm) | 30 VAC/DC 0.5 A, potential-free, SPDT |
| Alarm relay 2 (switching threshold 8 ppm) | 30 VAC/DC 0.5 A, potential-free SPNO/SPNC |
| Power consumption | 30 mA, (max. 0.8 VA) |
| Heating | |
| Temperature controlled | 3 °C ±2°C (37.5 °F ± 3.6 °F) |
| Ambient temperature | - 40 °C (- 40 °F) |
| Power consumption | 0.3 A; 7.5 VA |

10 Figures

Application: Analog mode
Fig. 1

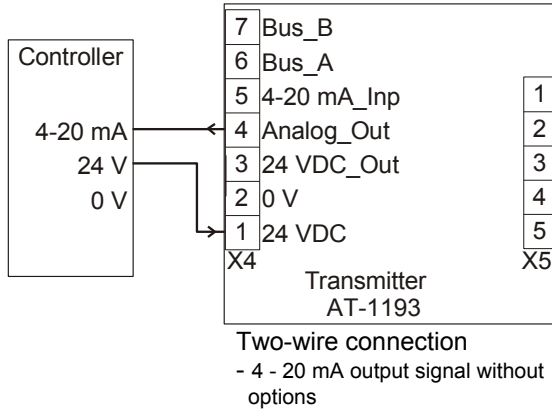

**Do not connect power supply at this pin.
(0 VDC, 24 VAC or 0VAC will destroy the transmitter.)**

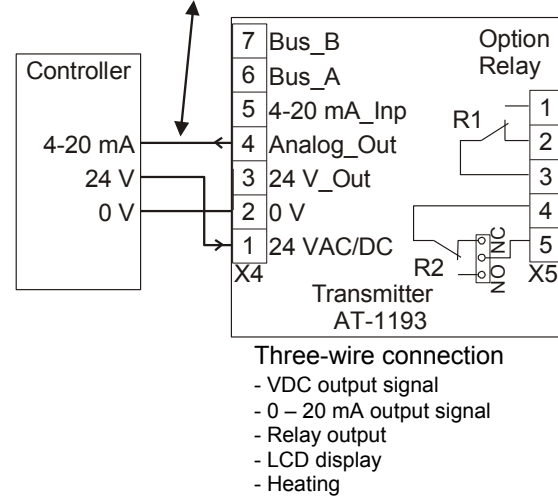

Do not connect 24 VAC at pin 2 and pin 4
or +24 VDC at pin 2 and 0 VDC at pin 4!!
Short-circuit = R 10 Ohm burns up!!

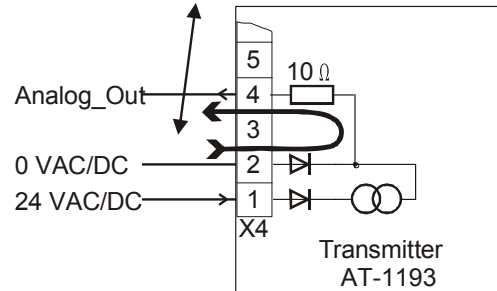

PCB
Fig. 3

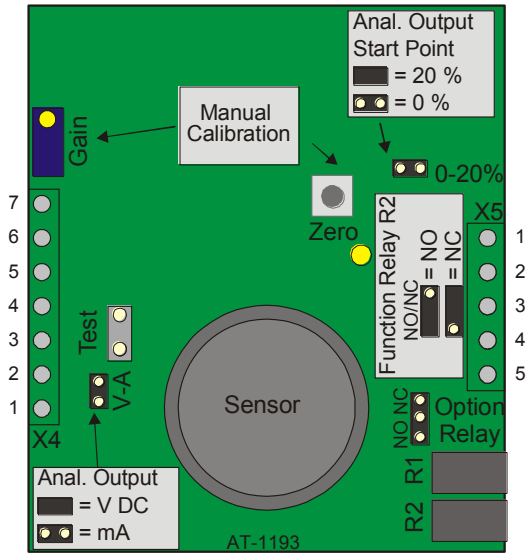

Terminal block

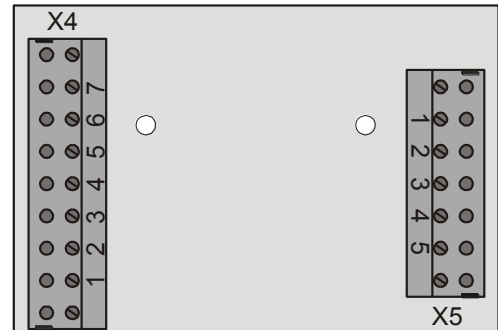

Selection analog output signal
Fig. 4

| Jumper 0- 20 % | Jumper V-A | Output signal |
|----------------|------------|---------------|
| Not set | Not set | 0 – 20 mA |
| Set | Not set | 4 – 20 mA |
| Not set | Set | 0 – 10 V |
| Set | Set | 2 – 10 V |

Calibration adapter
Fig. 5
Type: CONKIT-E/CH-AT



11 Part Disposal

Since August 2005 there are EC-wide directives defined in the EC Directive 2002/96/EC and in national codes concerning the waste electrical and electronic equipment and also regarding this device.

For private households there are special collecting and recycling possibilities. For this device isn't registered for the use in private households, it mustn't be disposed this way. You can send it back to your national sales organization for disposal. If there are any questions concerning disposal please contact your national sales organization.

Outside the EC, you have to consider the corresponding directives.

12 Notes and General Information

It is important to read this user manual thoroughly and clearly in order to understand the information and instructions. The PolyGard® transmitters must be used within product specification capabilities. The appropriate operating and maintenance instructions and recommendations must be followed.

Due to on-going product development, MSR and INTEC Controls reserve the right to change specifications without notice. The information contained herein is based upon data considered to be accurate. However, no guarantee is expressed or implied regarding the accuracy of this data.

12.1 Intended Product Application

The PolyGard® Cl₂ transmitters are designed and manufactured for control applications and air quality compliance in commercial buildings and manufacturing plants.

12.2 Installers' Responsibilities

It is the installer's responsibility to ensure that all PolyGard® transmitters are installed in compliance with all national and local codes and OSHA requirements. Installation should be implemented only by technicians familiar with proper installation techniques and with codes, standards and proper safety procedures for control installations and the latest edition of the National Electrical Code (ANSI/NFPA70). It is also essential to follow strictly all instructions as provided in the user manual.

12.3 Maintenance

It is recommended to check the PolyGard® transmitter regularly. Due to regular maintenance any performance deviations may easily be corrected. Re-calibration and part replacement in the field may be implemented by a qualified technician and with the appropriate tools. Alternatively, the easily removable plug-in transmitter card with the sensor may be returned for service to INTEC Controls.

12.4 Limited Warranty

MSR-Electronic-GmbH and INTEC Controls warrants the PolyGard® transmitters for a period of (2) years from the date of shipment against defects in material or workmanship and 12 months normal exposure for sensor element. Should any evidence of defects in material or workmanship occur during the warranty period, INTEC Controls will repair or replace the product at their own discretion, without charge.

This warranty does not apply to units that have been altered, had attempted repair, or been subject to abuse, accidental or otherwise. The warranty also does not apply to units in which the sensor element has been overexposed or gas poisoned. The above warranty is in lieu of all other express warranties, obligations or liabilities.

This warranty applies only to the PolyGard® transmitter. MSR-Electronic-GmbH and INTEC Controls shall not be liable for any incidental or consequential damages arising out of or related to the use of the PolyGard® transmitters.

If the PolyGard® transmitter needs to be returned to INTEC Controls for service, an RMA number must be obtained prior to sending.