

---

**User's  
Manual**

**Model PUS400G  
Ultrasonic Oscillator**

IM 19C1B3-01E

---

**vigilantplant.®**

# ◆ INTRODUCTION

This user’s manual describes instructions for handling of the PUS400G ultrasonic oscillator, including procedures for installation, operation, inspection and maintenance. Also, information necessary for you to further understand the product is described as required.

For handling of an ultrasonic vibrator for use together with this apparatus, refer to the user’s manual attached to the instrument with the ultrasonic vibrator built in.

Model	Title	IM No.
PH8HS	Submersion Type Holder	IM 12B07M01-01E
PH8HF	Flow-Through Type Holder	IM 12B07N01-01E

In continuous water quality measurement, pollutive components sticking to the sensor of a water quality meter is one of the causes of inaccurate measuring results. Therefore, cleaning of the sensor is an indispensable maintenance item for a lot of water quality meters.

Ultrasonic cleaning is one of methods for cleaning sensors. The major strong point of ultrasonic cleaning is that you can continuously perform it while making measurement. Ultrasonic cleaning has cleaning effect on most of pollutive components. Water quality meters mean pH or ORP meter.

The PUS400G ultrasonic oscillator is an apparatus for supplying an ultrasonic vibrator, built in a water quality meter, with high-frequency energy.

Below is the description of what you should do before use of the apparatus and what you should understand before reading this instruction manual.

### Specification Check

Unpack your ultrasonic oscillator with care, and check for any damage that may be caused during transport.

The PUS400G ultrasonic oscillator is fabricated to the customer specifications. For precautionary purposes, check to see that your ultrasonic oscillator is in accordance with your specifications, and that there is no missing accessory. Use the model codes indicated on the nameplate to check the specifications of your ultrasonic oscillators. For the meaning of the model codes, refer to Section 1.2.

**Location of Nameplate: Panel inside apparatus.**

US OSCILLATOR	
MODEL	PUS400G
SUFFIX	-NN-NN-1-E
SUPPLY	100 V AC
	50/60 Hz
STYLE	
NO.	

Example on Indication of Nameplate

### Precautions Which Must Be Taken when Actuating PUS400G Ultrasonic Oscillator during Inspection



### NOTE

When actuating the PUS400G ultrasonic oscillator, be sure to connect the ultrasonic vibrator (under load, that is, immersed in fluid) as under normal operating conditions. Operating the ultrasonic oscillator solely (or, with the ultrasonic vibrator under no load connected) may cause some electric parts to be abnormally heated. This is unfavorable in terms of the life of the ultrasonic oscillator.

# ◆ For the safe use of this equipment

## ■ Safety, Protection, and Modification of the Product

- In order to protect the system controlled by the product and the product itself and ensure safe operation, observe the safety precautions described in this user's manual. We assume no liability for safety if users fail to observe these instructions when operating the product.
- If this instrument is used in a manner not specified in this user's manual, the protection provided by this instrument may be impaired.
- Be sure to use the spare parts approved by Yokogawa Electric Corporation (hereafter simply referred to as YOKOGAWA) when replacing parts or consumables.
- Modification of the product is strictly prohibited.
- The following symbols are used in the product and user's manual to indicate that there are precautions for safety:

## ■ Notes on Handling User's Manuals

- Please hand over the user's manuals to your end users so that they can keep the user's manuals on hand for convenient reference.
- Please read the information thoroughly before using the product.
- The purpose of these user's manuals is not to warrant that the product is well suited to any particular purpose but rather to describe the functional details of the product.
- No part of the user's manuals may be transferred or reproduced without prior written consent from YOKOGAWA.
- YOKOGAWA reserves the right to make improvements in the user's manuals and product at any time, without notice or obligation.
- If you have any questions, or you find mistakes or omissions in the user's manuals, please contact our sales representative or your local distributor.

## ■ Warning and Disclaimer

The product is provided on an "as is" basis. YOKOGAWA shall have neither liability nor responsibility to any person or entity with respect to any direct or indirect loss or damage arising from using the product or any defect of the product that YOKOGAWA can not predict in advance.

## ■ Symbol Marks

Throughout this user's manual, you will find several different types of symbols are used to identify different sections of text. This section describes these icons.



### **WARNING**

---

---

Indicates a potentially hazardous situation which, if not avoided, could result in death or serious injury.

---

---



### **CAUTION**

---

Indicates a potentially hazardous situation which, if not avoided, may result in minor or moderate injury. It may also be used to alert against unsafe practices.

---



### **IMPORTANT**

---

Indicates that operating the hardware or software in this manner may damage it or lead to system failure.

---



### **NOTE**

---

Draws attention to information essential for understanding the operation and features.

---

---

## ◆ After-sales Warranty

- **Do not modify the product.**
  
- **During the warranty period, for repair under warranty consult the local sales representative or service office. Yokogawa will replace or repair any damaged parts. Before consulting for repair under warranty, provide us with the model name and serial number and a description of the problem. Any diagrams or data explaining the problem would also be appreciated.**
  - If we replace the product with a new one, we won't provide you with a repair report.
  - Yokogawa warrants the product for the period stated in the pre-purchase quotation. Yokogawa shall conduct defined warranty service based on its standard. When the customer site is located outside of the service area, a fee for dispatching the maintenance engineer will be charged to the customer.
  
- **In the following cases, customer will be charged repair fee regardless of warranty period.**
  - Failure of components which are out of scope of warranty stated in instruction manual.
  - Failure caused by usage of software, hardware or auxiliary equipment, which Yokogawa Electric did not supply.
  - Failure due to improper or insufficient maintenance by user.
  - Failure due to modification, misuse or outside-of-specifications operation which Yokogawa does not authorize.
  - Failure due to power supply (voltage, frequency) being outside specifications or abnormal.
  - Failure caused by any usage out of scope of recommended usage.
  - Any damage from fire, earthquake, storms and floods, lightning, disturbances, riots, warfare, radiation and other natural changes.
  
- **Yokogawa does not warrant conformance with the specific application at the user site. Yokogawa will not bear direct/indirect responsibility for damage due to a specific application.**
  
- **Yokogawa Electric will not bear responsibility when the user configures the product into systems or resells the product.**
  
- **Maintenance service and supplying repair parts will be covered for five years after the production ends. For repair for this product, please contact the nearest sales office described in this instruction manual.**

# Model PUS400G Ultrasonic Oscillator

IM 19C1B3-01E 6th Edition

## CONTENTS

- ◆ INTRODUCTION .....i
- ◆ For the safe use of this equipment .....ii
- ◆ After-sales Warranty .....iv
- 1. Overview ..... 1-1
  - 1.1 Standard Specifications ..... 1-1
  - 1.2 Model and Suffix Codes ..... 1-2
  - 1.3 External Dimensions ..... 1-3
- 2. Installation and Wiring ..... 2-1
  - 2.1 Installation ..... 2-1
    - 2.1.1 Installation Site ..... 2-1
    - 2.1.2 Installing Procedure ..... 2-2
  - 2.2 Wiring ..... 2-4
    - 2.2.1 Types of Wiring ..... 2-4
    - 2.2.2 Cable Protection by Conduit ..... 2-4
    - 2.2.3 Connecting Ultrasonic Vibrator Cable ..... 2-5
    - 2.2.4 Power Supply Wiring ..... 2-5
    - 2.2.5 Ground Wiring ..... 2-5
- 3. Operation ..... 3-1
  - 3.1 Names and Function of Each Part ..... 3-1
  - 3.2 Preparation for Operation ..... 3-2
    - 3.2.1 Inspecting State of Wiring Installation ..... 3-2
  - 3.3 Steady State Operation ..... 3-2
    - 3.3.1 If In-Action Pilot Lamp Goes OFF (Related information: Section 4.2)3-2
    - 3.3.2 Stopping and Restarting Operation ..... 3-2
- 4. Inspection and Maintenance ..... 4-1
  - 4.1 Inspecting State of Ultrasonic Wave Application ..... 4-1
    - 4.1.1 Checking State of Ultrasonic Oscillator Operation ..... 4-1
    - 4.1.2 Checking Cleaning Effect ..... 4-1
  - 4.2 Inspection When In-Action Pilot Lamp is OFF ..... 4-2
    - 4.2.1 Cause of Pilot Lamp Going Out ..... 4-2
    - 4.2.2 Replacing Procedure for Fuse ..... 4-2
- 5. Troubleshooting ..... 5-1
  - 5.1 Remedies for Troubles ..... 5-1

---

5.1.1	Troubles and Possible Causes .....	5-1
5.1.2	Remedy for Supply Voltage Drop .....	5-1
<b>5.2</b>	<b>Part Replacing Procedure .....</b>	<b>5-2</b>
5.2.1	Replacing Ultrasonic Vibrator Cable.....	5-2
5.2.2	Inspecting and Replacing Procedures for Ultrasonic Vibrator .....	5-2
5.2.3	Inspection of and Repair to Ultrasonic Oscillator .....	5-2
<b>Customer Maintenance Parts List.....</b>		<b>CMPL 19C01B03-01E</b>
<b>Revision Information .....</b>		<b>i</b>

# 1. Overview

The PUS400G ultrasonic oscillator is an apparatus that composes an ultrasonic cleaner together with an ultrasonic piezoelectric transducer (vibrator). The PUS400G supplies the ultrasonic vibrator with operating power via a cable.

The ultrasonic vibrator to be combined with the PUS400G is a vibrator mode of lead zirconate-titanate-based piezoelectric ceramics.

The ultrasonic vibrator is built in the sensor holder of the pH meter.

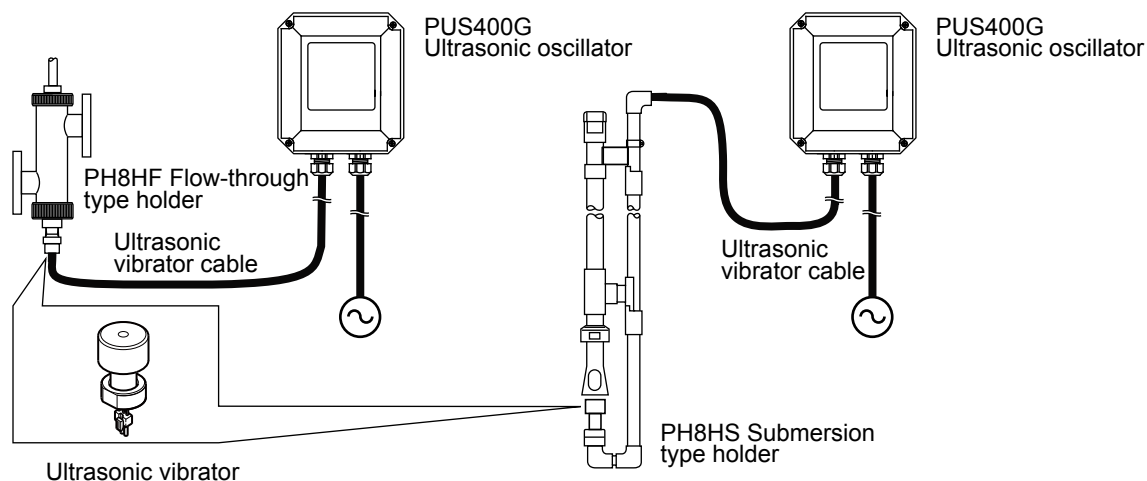

**Figure 1.1 Configuration of Ultrasonic Cleaner Using PUS400G Ultrasonic Oscillator**

This chapter gives the description of the specifications for the PUS400G ultrasonic oscillator.

## 1.1 Standard Specifications

Combination device:	Holder with ultrasonic cleaner (PH8HS, PH8HF) Connection cables are provided with holders.
Cleaning method:	Continuous ultrasonic emission (Frequency sweep method)
Oscillation frequency:	Approx. 61 to 81 kHz
Output voltage:	Approx. 70 V
	(Note) Output of ultrasonic oscillator changes with power supply voltage or connected cable length.
Power supply:	100/110/115/200/220/240 V AC±10% 50/60 Hz
Power consumption:	Approx. 15 VA
Ambient Temperature:	-10 to 50°C (hood may be fitting as option)
Storage Temperature:	-25 to 70°C
Construction:	JIS C0920 Watertight (NEMA 4 equivalent waterproof construction)
Material:	Case; Aluminium alloy casting Window; Polycarbonate Mounting bracket; Stainless steel
Finish:	Baked polyurethane resin (Standard) Baked epoxy resin (Option)
Color:	Case; Frosty white (Munsell 2.5Y8.4/1.2 or equivalent) Cover; Deep sea-moss green (Munsell 0.6GY3.1/2.0 equivalent)



Mounting:	2-inch pipe mounting, wall or rack mounting or panel mounting
Cable inlet:	Ø22.7 X 2 Pg16 watertight plastic gland
Cable / Terminal:	For 7 to 12 mm O.D, M4 screw
Conduit adapter:	Power supply side only (Option)
Connection:	G1/2 or 1/2NPT
Weight:	Body;   Approx. 2.0 kg
	Pipe mounting bracket;   Approx. 0.7 kg
	Wall mounting bracket;   Approx. 0.4 kg
Noise filter assembly:	(only for PUS400G-NN-KC)
Ambient temperature:	-10 to 50°C (no dew condensation allowed)
Strage temperature:	-25 to 70°C
Construction:	JIS C 0920 Watertight (IP53)

**Regulatory Compliance**                   (PUS400G-NN-KC)

Korea Electromagnetic Conformity Standard Class A                   한국 전자파적합성 기준

A급 기기 (업무용 방송통신기자재)  
 이 기기는 업무용(A급) 전자파적합기기로서 판매자 또는  
 사용자는 이 점을 주의하시기 바라며, 가정외의 지역에서  
 사용하는 것을 목적으로 합니다.

## 1.2 Model and Suffix Codes

Model	Suffix Code	Option Code	Description
PUS400G	.....	.....	Ultrasonic oscillator for pH meter
—	-NN	.....	Always -NN
Application	-NN -KC	.....	General purpose For Korea
Power Supply	-1 -2 -3 -4 -5 -6	.....	100V AC 50/60Hz 110V AC 50/60Hz 115V AC 50/60Hz 200V AC 50/60Hz 220V AC 50/60Hz 240V AC 50/60Hz
Language	-E -J	.....	English Japanese
Option	Mounting Bracket  Hood  Special Finish Tag Plate Conduit Adaptor	/PS /W /PA /H /H2 /X1 /SCT /AFTG /ANSI /SPS	Pipe mounting bracket (stainless steel) Wall mounting bracket (stainless steel) Panel mounting bracket (stainless steel) Awning hood (carbon steel) Awning hood (stainless steel) Baked epoxy resin Stainless steel tag plate G1/2 1/2 NPT Teflon coated SUS steel screws

**Accessories**

Part Name	Part Number	Remarks
Spare Fuse	K9317AZ	1 A : 1 pc, 2 A : 2 pcs

### 1.3 External Dimensions

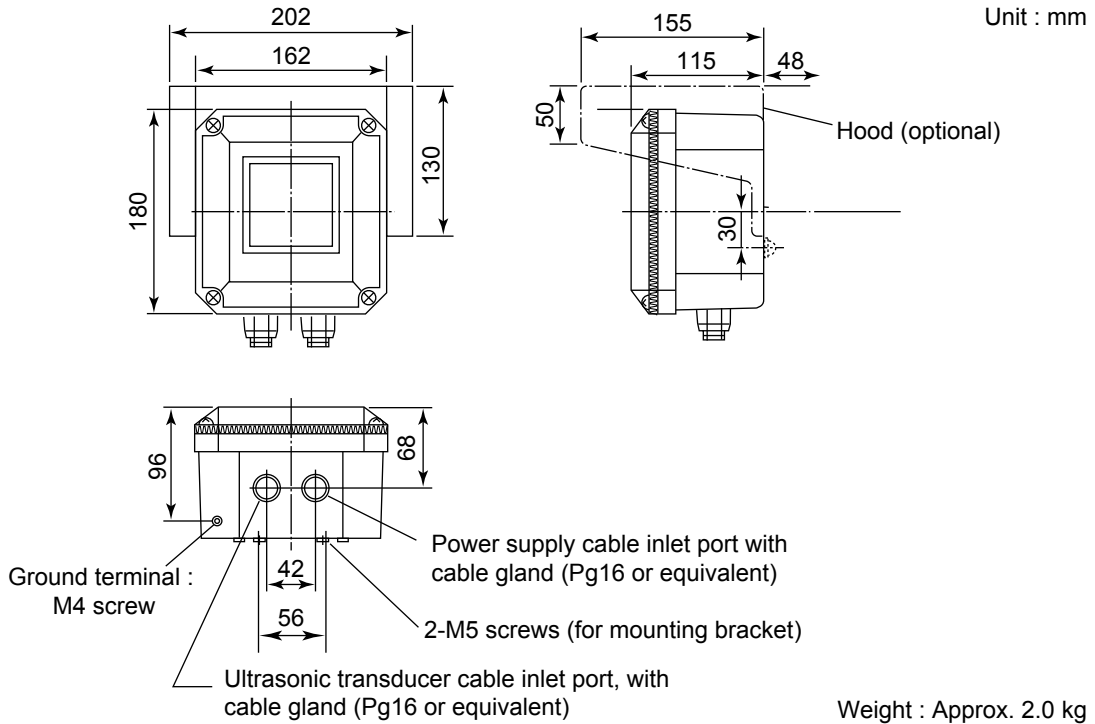

#### Conduit connecting adapter (option code: /AFTG, /ANSI)

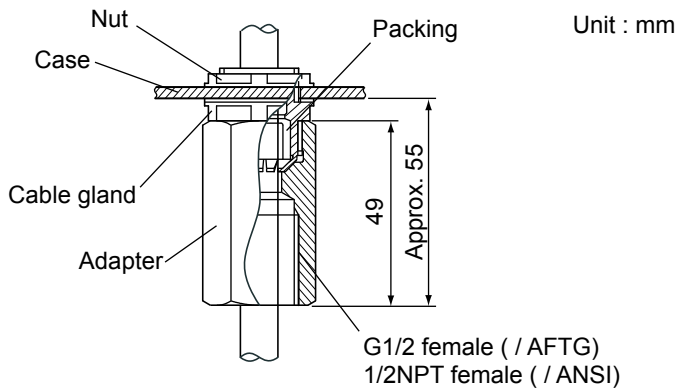

#### Pipe Mounting Bracket (option code: /PS)

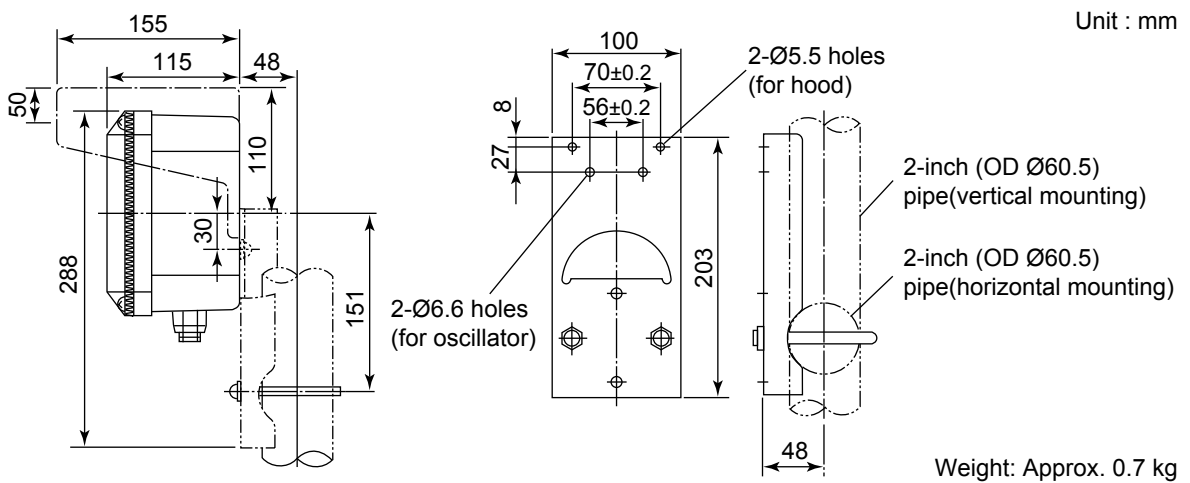

**Panel Mounting Bracket (option code: /PA)**

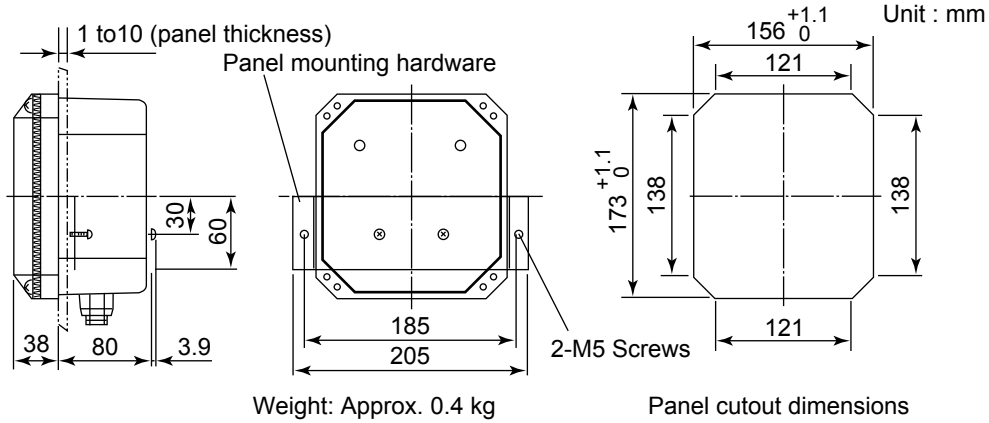

**Wall Mounting Bracket (option code: /W)**

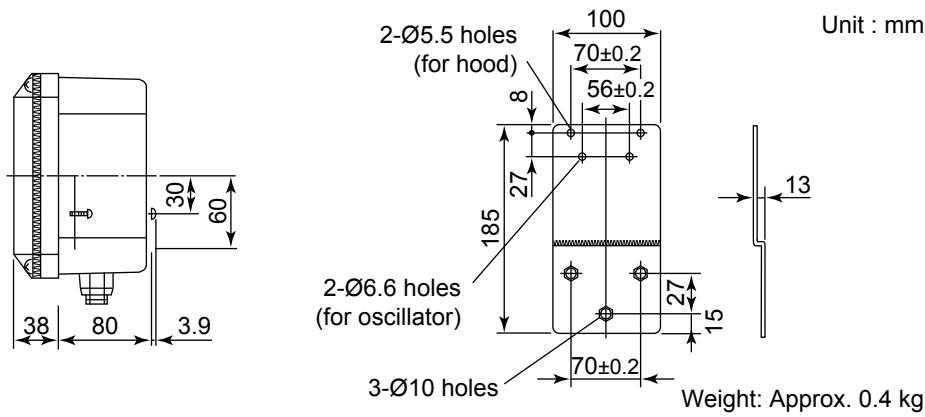

**Noise filter assembly (only for PUS400G-NN-KC)**

Unit: mm

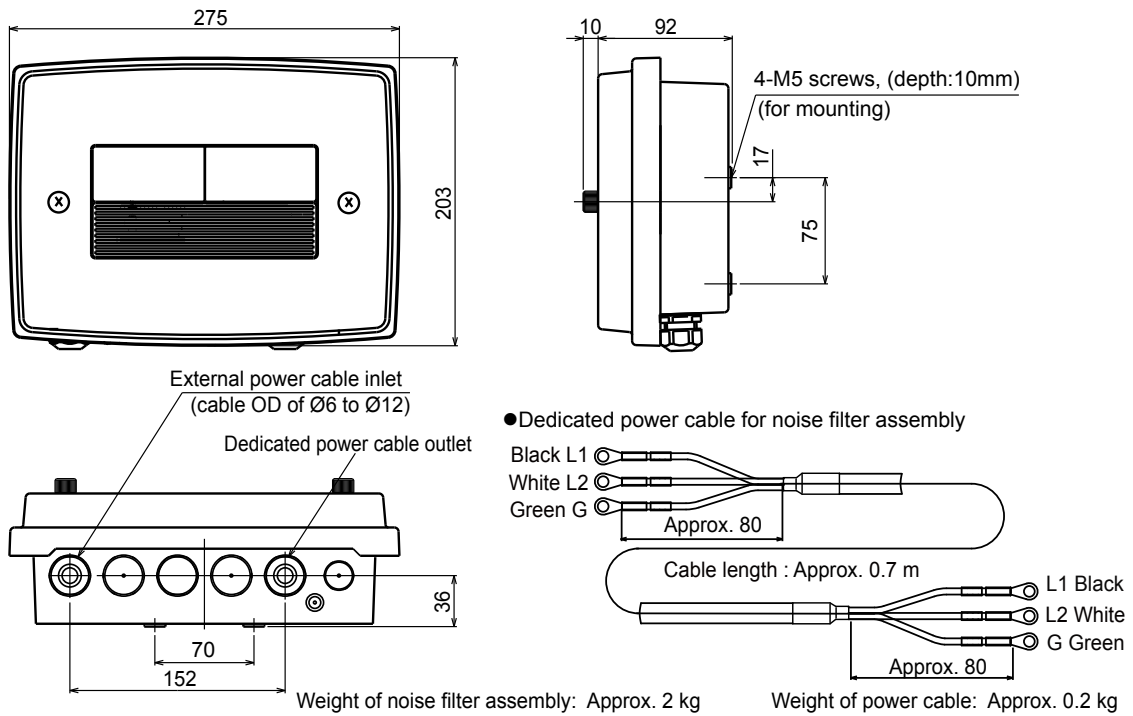

• Pipe Mounting Bracket for Noise filter assembly (option code: /PS)

Unit: mm

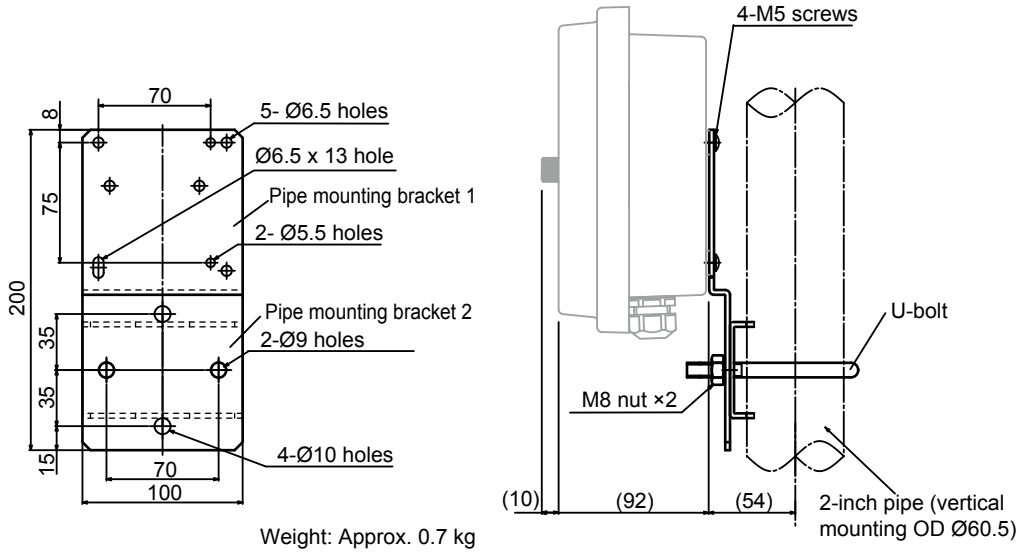

• Wall or Panel Mounting Bracket for Noise filter assembly (option code: /W, /PA)

Unit: mm

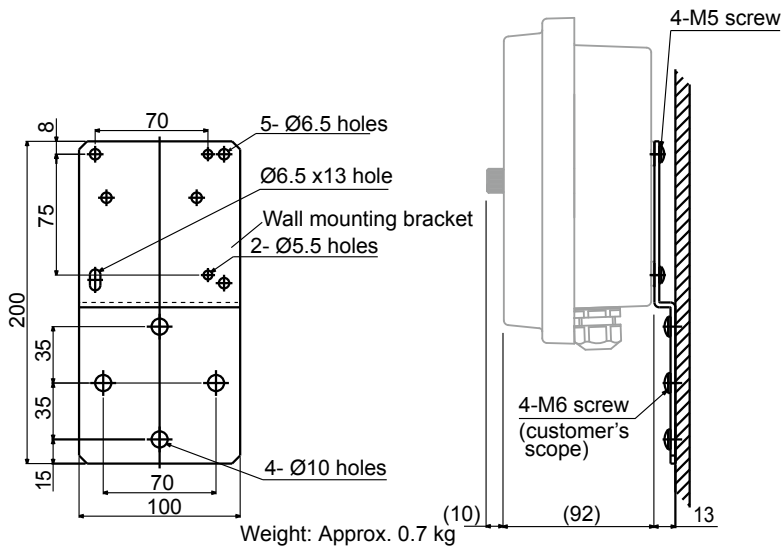



## 2. Installation and Wiring

The PUS400G ultrasonic oscillator should be installed in a place where the power switch is easily turned ON/OFF and the “in-action” pilot lamp. Install the PUS400G as close to the pH meter sensor holder as possible.

This chapter describes how to select an installation site and procedures for installation and wiring.

### 2.1 Installation

The PUS400G ultrasonic oscillator may be installed outdoors. However, it should be installed in as favorable an environment as possible in order to keep its electric circuits in good condition.

#### 2.1.1 Installation Site

Install the PUS400G ultrasonic oscillator in a place where the following requirements are met:

- **The PUS400G must be installed as close to the location of the ultrasonic vibrator as possible.**

The cable of the ultrasonic piezoelectric transducer (ultrasonic vibrator cable) built in the sensor holder of the pH meter is at most three meters (flow-through type holder) or five meters (submersion type holder) in length. The ultrasonic oscillator must be installed close to the ultrasonic vibrator.

- **The PUS400G must be installed in a place free from corrosive gases.**
- **The PUS400G must be installed in a place with less fluctuation in temperature at ordinary temperature or a temperature close to ordinary temperature.**

The fluctuation in temperature at the installation site should be within the range of -10 to 50°C.

- **The PUS400G must be installed in a place where a humidity of 5 to 90% HR is maintained.**

Avoid installing the ultrasonic oscillator in a place where a high or low humidity is maintained for a long time. It is recommended to always operate the PUS400G at a humidity of 25 to 85% RH.

- **The PUS400G must be installed in a place not exposed to direct sunlight.**

Direct sunlight may excessively increase temperature in the oscillator. If there is any high temperature equipment nearby, temperature in the oscillator may be also excessively increased due to radiant heat. If temperature in the oscillator is likely to rise and exceed allowable limit due to direct sunlight, then install a sunshade hood (optional)

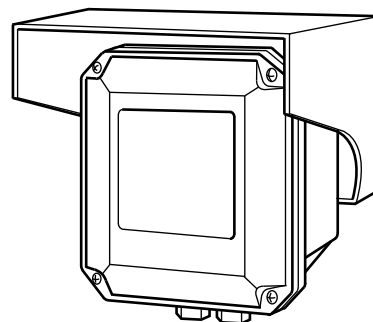

Figure 2.1 Sunshade as Installed

### 2.1.2 Installing Procedure

The ultrasonic oscillator may be mounted on panel, a wall surface or a pipe (2-inch, OD: 60.5 mm). Hardware corresponding to the type of mounting used is required to install the PUS400G. Mounting hardware is attached only when requested.

In the case of PUS400G-NN-KC (for Korea), a noise filter assembly is attached. Please refer to a figure of external dimensions for the attachment means of the noise filter assembly.

#### (1) Panel Mounting

Figure 2.2 illustrates the installing procedure for the ultrasonic oscillator using panel mounting bracket.

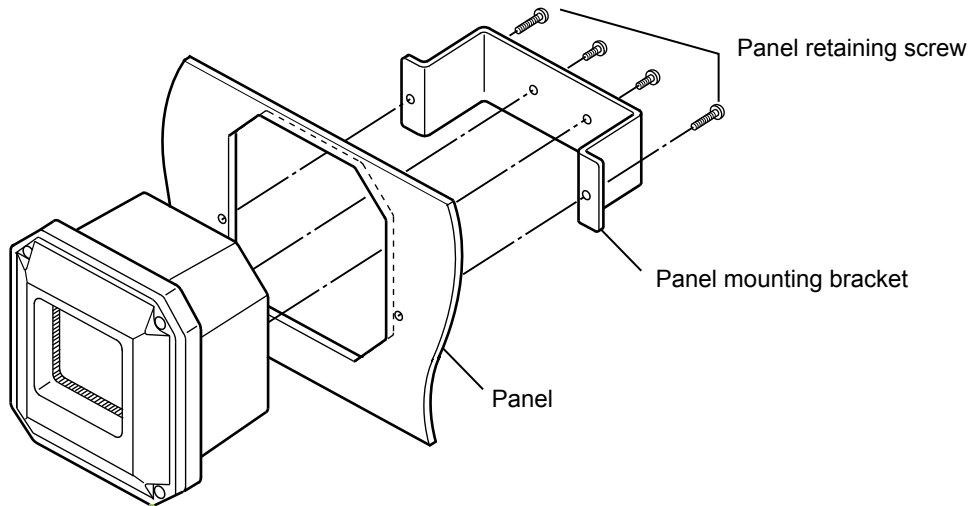

**Figure 2.2 Mounting Method for Ultrasonic Oscillator Using Panel Mounting Bracket**

To mount the PUS400G on a panel, cut out the panel in accordance with Figure 2.3.

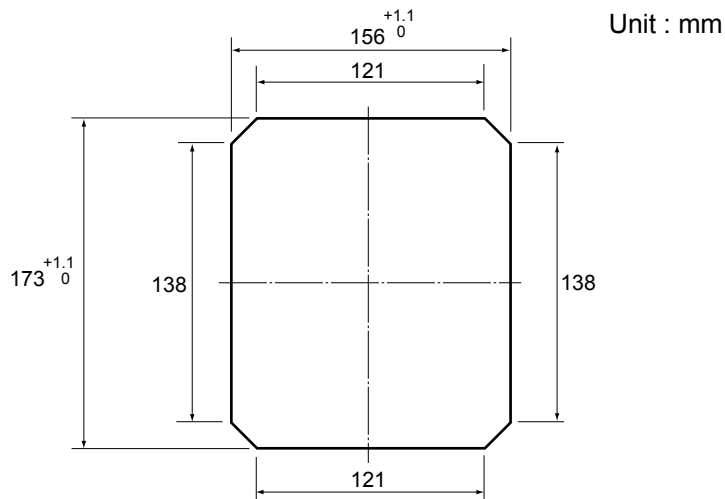
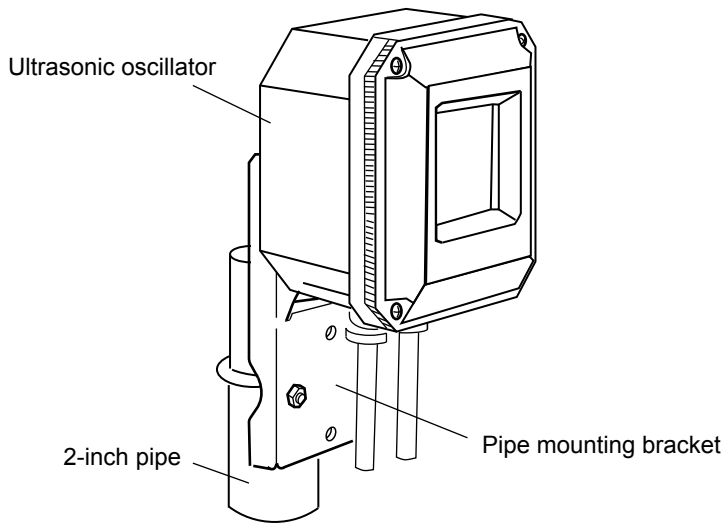

**Figure 2.3 Panel Cutout Dimensions**

**(2) Pipe Mounting**

When mounting the PUS400G on a pipe, install a pipe (2-inch, OD: 60.5 mm) in the vertical or horizontal direction.

Figure 2.4 illustrates the installing procedure for the ultrasonic oscillator using pipe mounting bracket.

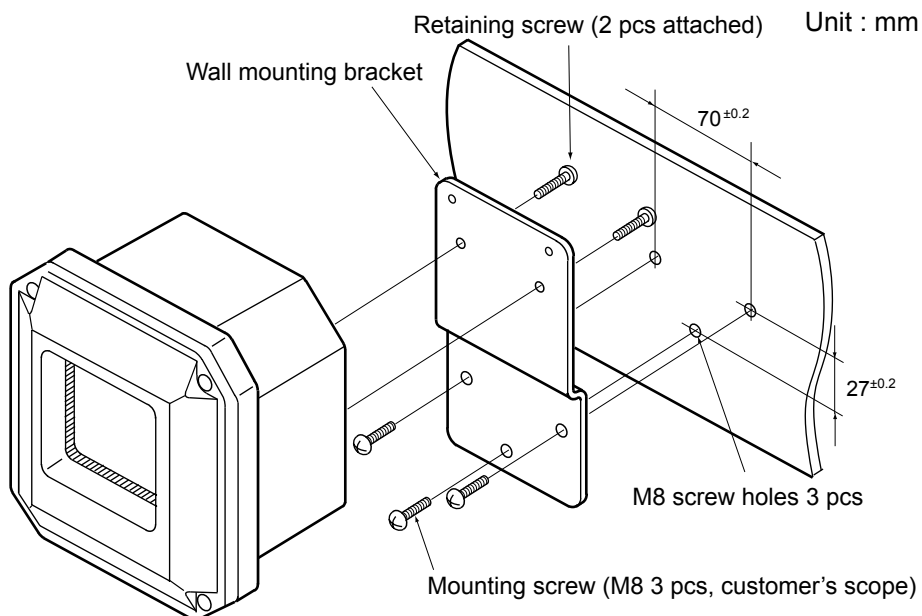

**Figure 2.4 Ultrasonic Oscillator as Mounted on Pipe**

**(3) Wall Mounting**

Figure 2.5 illustrates the installing procedure for the ultrasonic oscillator using wall mounting bracket.

Drill screw holes (for M8 screw, 3 places) in accordance with the figure below before mounting the PUS400G.



**Figure 2.5 Hardware and Procedure for Wall Mounting**



## 2.2 Wiring

This section describes types of wiring installed for the PUS400G ultrasonic oscillator and wiring work procedures type by type.

### 2.2.1 Types of Wiring

There are three types of wiring installed for the PUS400G ultrasonic oscillator. The ultrasonic vibrator cable (of a specified length) is attached to the sensor holder of the pH meter.

- **Ultrasonic vibrator cable connection (power line for ultrasonic vibrator)**
- **Power supply wiring**
- **Grounding wiring**

Figure 2.6 illustrates the connecting terminals for these types of wiring.

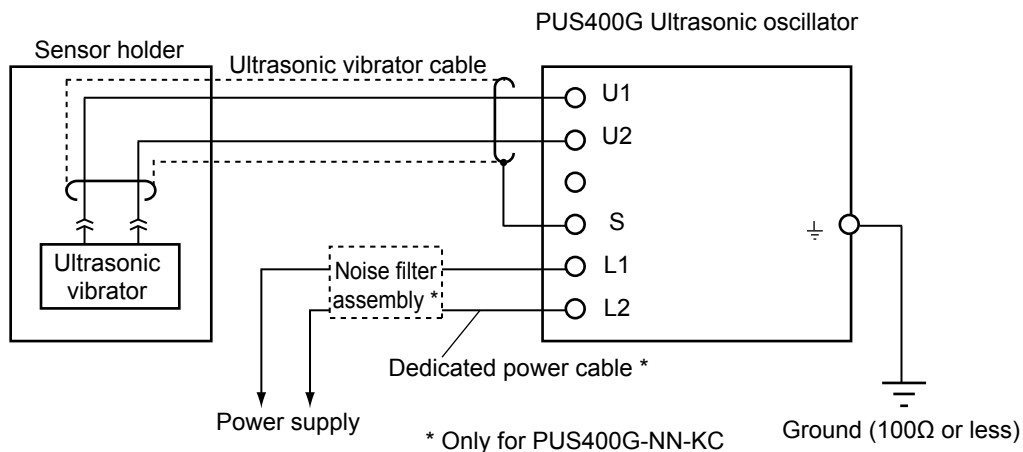

**Figure 2.6 External Wiring Diagram**

### 2.2.2 Cable Protection by Conduit

The power cable connected to the ultrasonic oscillator can be protected by conduits to prevent damage to its coating. In this case a dedicated cable gland with an adapter for conduit connection is required. The cable gland with an adapter is attached only when requested.

#### [Mounting Procedure for Cable Gland with Conduit Connecting Adapter]

Remove the cable gland (DIN Pg16 or equivalent) from the cable inlet in the ultrasonic oscillator, and install the attached cable gland (JIS 15A or equivalent) and the adapter for conduit connection, as shown in Figure 2.7.

Firmly tighten the gasket to prevent moisture from entering the oscillator through the cable inlet.

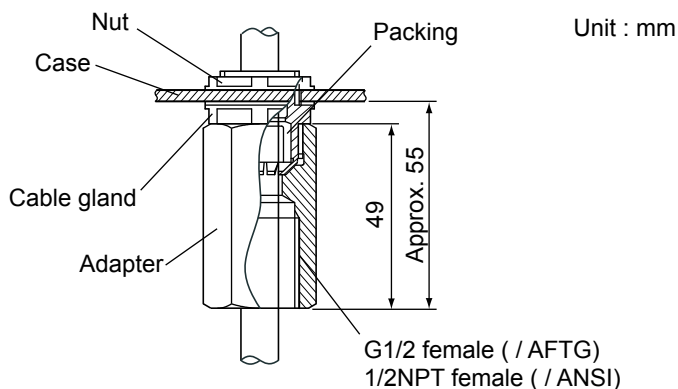

**Figure 2.7 How to Install Adapter for Conduit Work**

### 2.2.3 Connecting Ultrasonic Vibrator Cable

Connect the cable of the ultrasonic vibrator (power line for ultrasonic vibrator) to Terminals U1, U2 and S on the PUS400G ultrasonic oscillator.

The ultrasonic vibrator cable must be connected direct to the terminals on the ultrasonic oscillator. If the length of the ultrasonic vibrator cable is insufficient, shift the location of the installation of the ultrasonic oscillator close to the pH holder.

The ultrasonic vibrator cable is provided with a cable gland (JIS A8 or equivalent).

This cable gland is unnecessary if the ultrasonic vibrator cable is connected to the PUS400G ultrasonic oscillator. Remove it or shift it to a position where wiring work will not be interfered with.

### 2.2.4 Power Supply Wiring

Use a two-core cable with a conductor nominal cross-sectional area of 0.5 mm<sup>2</sup> or above for power supply wiring.

Connect the cable from a power supply having a specified voltage (voltage fluctuation: within a range of  $\pm 10\%$  of nominal voltage) to Terminal L1 and L2 on the ultrasonic vibrator.

Note: If the supply voltage drops below the allowable range, the power of ultrasonic waves is weakened, which may result in the degradation in cleaning effect.

The screw size of the terminals is M4. Use a crimp contact conformable to the size for cable termination.

Place in the power supply wiring a switch for shutting off the power supply to the ultrasonic oscillator. With this switch provided, safety is ensured when the wires are removed from the ultrasonic oscillator for repair or the like. Use the power switch inside the PUS400G ultrasonic oscillator to start or stop it for or during steady state operation.

In the case of PUS400G-NN-KC (for Korea), please wire a noise filter assembly by all means.

### 2.2.5 Ground Wiring

The PUS400G ultrasonic oscillator should be grounded to earth (grounding resistance: 100 $\Omega$  or below). Use a conductor with a nominal cross-sectional area of 2 mm<sup>2</sup> or above. The grounding terminal is located on the left side at the lower part of the case (when viewed from front) (Refer to the external dimensions on Sec. 1.3.) The terminal uses a M4 screw.



# 3. Operation

The PUS400G ultrasonic oscillator should be actuated when the pH meter is operated. This chapter describes inspections before starting operation and operating procedure.

## 3.1 Names and Function of Each Part

You can see the in-action pilot lamp through the window in the front cover. When you remove the front cover, you can find the power switch, fuses and so on.

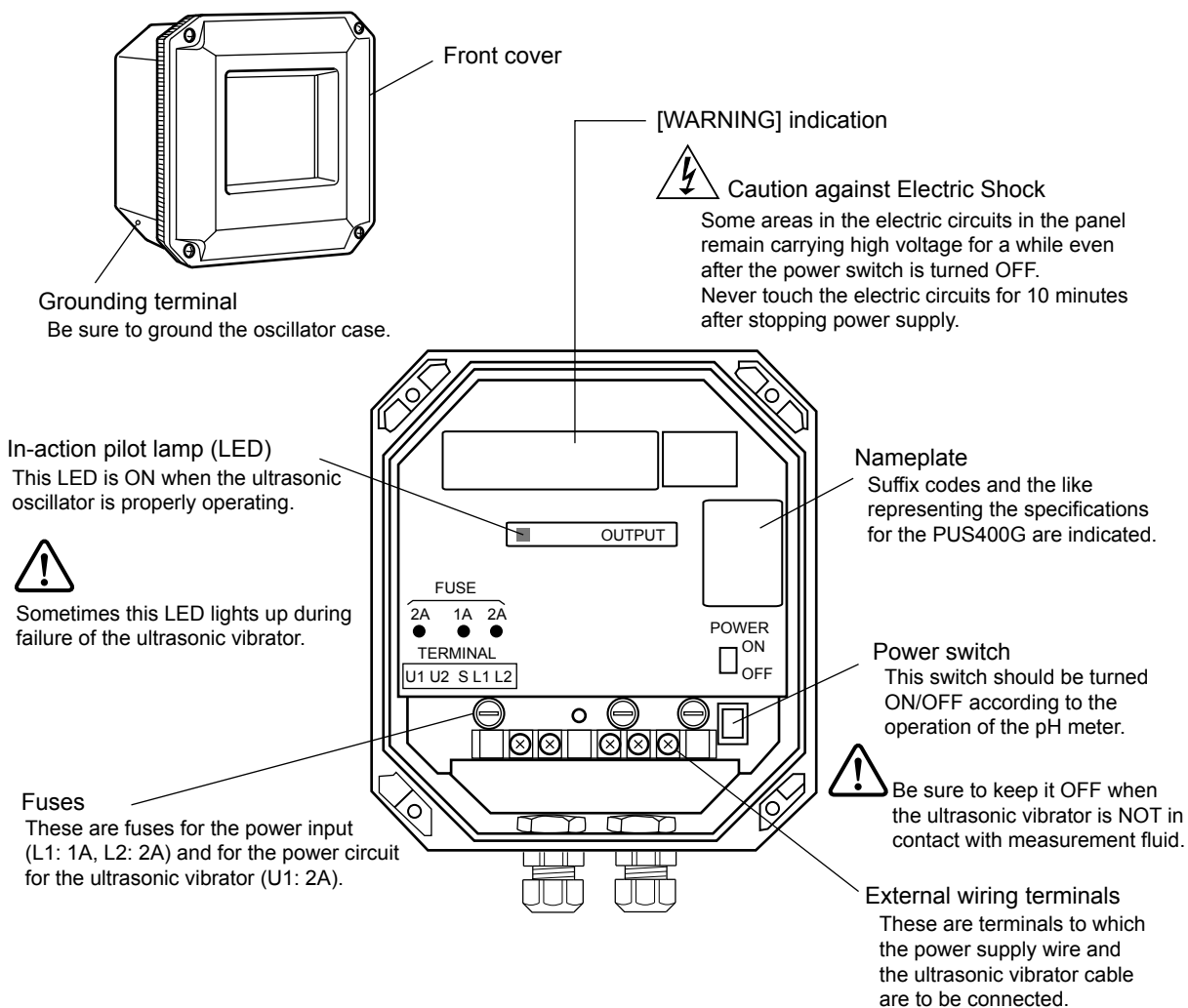

Figure 3.1 Names and Function of Each Part in PUS400G Ultrasonic Oscillator

## 3.2 Preparation for Operation

Inspect the state of wiring installation before starting the steady state operation of the PUS400G ultrasonic oscillator.

### 3.2.1 Inspecting State of Wiring Installation

Check to see that the wiring work has been properly executed to meet the following requirement:

- **The ultrasonic vibrator cable must be properly connected to the right terminals (U1, U2, S) on the ultrasonic oscillator.**
- **A power supply of the specified voltage with voltage fluctuation within the allowable range must be available to Terminals L1 and L2 on the ultrasonic oscillator.**

For precautionary purposes, check to see that the fuses (three places) are firmly installed.



#### NOTE

With the ultrasonic vibrator unconnected, the in-action pilot lamp will not light up even if power is supplied. Do not operate the ultrasonic oscillator with the ultrasonic vibrator NOT in contact with fluid. Attention should be given especially when an existing two-core shielded cable is used. With the ultrasonic vibrator NOT in contact with fluid, some parts in the electric circuits are excessively heated to a temperature higher than in ordinary operation. This is unfavorable in terms of the life of the ultrasonic oscillator.

- **The ultrasonic oscillator must be grounded (grounding resistance: 100Ω or below.)**

## 3.3 Steady State Operation

The ultrasonic oscillator should be operated only when the ultrasonic vibrator is in contact with fluid. If it is operated with the ultrasonic vibrator exposed to the air, or with no load, the temperature of the electric circuit parts excessively rises, which has harmful effect on life of the ultrasonic oscillator.

Once the operation of the ultrasonic oscillator is started, it is unnecessary for the operator to control it during the subsequent steady state operation. When inspecting the pH meter, however, check to see that the in-action pilot lamp is ON.

### 3.3.1 If In-Action Pilot Lamp Goes OFF (Related information: Section 4.2)

If the in-action pilot lamp goes off, the possible causes are:

- **Failure in Electric Circuits.**
- **Any fuse in the oscillator has burnt out.**

#### [In Case Fuse Has Burnt Out]

Replace the burnt fuse with a new one. (Refer to Subsection 4.2.2.)

### 3.3.2 Stopping and Restarting Operation

For the prevention of trouble in the PUS400G ultrasonic oscillator and the ultrasonic vibrator, it is important to avoid operating the ultrasonic vibrator with no load (i.e. NOT in contact with measurement fluid.) When performing maintenance work (standard solution calibration, etc.) on the pH meter, turn OFF the power switch in the ultrasonic oscillator and then pull the ultrasonic vibrator out of measurement fluid. To restart pH measuring operation, immerse the ultrasonic vibrator in the measurement fluid and then turn ON the power switch in the ultrasonic oscillator.

## 4. Inspection and Maintenance

This chapter describes routine inspection and maintenance work required to allow the PUS400G ultrasonic oscillator to fully deliver its performance and to obtain favorable cleaning results.

Refer to “5. Troubleshooting” in this manual for the improvements of the equipment preventing the achievement unfavorable cleaning effect and the remedies for troubles in the equipment.

### 4.1 Inspecting State of Ultrasonic Wave Application

If ultrasonic wave application does not have sufficient cleaning effect, it is impossible to accomplish the purpose of ultrasonic cleaning of maintaining accurate pH measurement for a long time. Check whether the ultrasonic oscillator is normally operating whenever maintenance work is performed on the pH meter.

#### 4.1.1 Checking State of Ultrasonic Oscillator Operation

During pH measurement, check to see that the ultrasonic oscillator is satisfactorily operating as well. To do this, check whether the in-action pilot lamp inside the oscillator is ON.

If not, perform maintenance work in accordance with the instructions described in Section 4.2.

#### 4.1.2 Checking Cleaning Effect

Visually check the cleaning effect on the pH sensor whenever maintenance work (Standard solution calibration, etc.) is performed on the pH meter. If soil on the glass electrode area and the fluid-contacting area is not so prominent as compared with the other parts, the effect of ultrasonic cleaning is satisfactory.



#### NOTE

Measurement errors are caused by the chemical contamination of the sensitive film on the glass electrode as well as the adhesion of contaminants contained in measurement fluid. Refer to the user's manual for the pH meter for the removal of soil insusceptible to ultrasonic cleaning, such as chemical contamination.

If any adhesive contaminant, such as those contained in measurement fluid, is sticking to the fluid-contacting area (especially, vibrating surface) of the ultrasonic vibrator, remove it; otherwise, the cleaning effect is impaired.

If any adhesive contaminant is contained in measurement fluid, take necessary measures to prevent soil sticking to the ultrasonic vibrator from being hardened (dried) when the ultrasonic oscillator is out of operation.

The fluid-contacting area of the ultrasonic vibrator is made of a material resistant to the corrosion due to measurement fluid (SUS316, Hastelloy C or titanium; in most cases, a problem associated with corrosion will not come up. If any change in the properties of measurement fluid (change in constituents, etc.) is encountered, check for corrosion (pitting, etc.) for precautionary purposes. If corrosion develops so far that fluid begins to enter the interior of the ultrasonic vibrator, it may be required to replace other parts together with it.

## 4.2 Inspection When In-Action Pilot Lamp is OFF

The in-action pilot lamp may be kept OFF by erroneous operation (e.g. forgetting to turn ON the power switch), or some trouble, such as anomalies in the wiring (disconnection and short circuit) and faults in the equipment.

If the cause is such trouble, cope with it referring to Chapter 5.

### 4.2.1 Cause of Pilot Lamp Going Out

The following are suspected to be the cause of the in-action pilot lamp going out:

- **Any of the fuses has burnt out.**

The ultrasonic oscillator has two fuses, 1A and 2A, in the power receiving circuit and a 2A fuse in the power circuit for the ultrasonic vibrator.

Turn OFF the power switch and check whether any of the fuses has burnt out. Refer to Subsection 4.2.2 for details.

- **The power cable for ultrasonic vibrator is disconnected or short-circuited.**

The in-action pilot lamp goes out for the same reason as the case where the ultrasonic vibrator is not immersed in fluid.

First, check to see that the cable is connected to the terminals on the ultrasonic oscillator with reliability. Next, check the cable for any disconnection or short circuit using a tester or the like.

If the cable turns out to be faulty, cope with it in the instructions described in Subsection 5.2.1.

- **There is a problem in the ultrasonic vibrator.**

If the pilot lamp going out is caused by neither of the two above-mentioned problems, the cause is often trouble in the ultrasonic vibrator.

Check the surface of the fluid-contacting area of the ultrasonic vibrator for any pit due to corrosion. Referring to the user's manual for the pH meter, examine the power supply circuit for the ultrasonic vibrator in the holder.

If the cause of the in-action pilot lamp going out cannot be identified even after checking all the above-mentioned items, contact YOKOGAWA.

### 4.2.2 Replacing Procedure for Fuse

(Check to see that the power switch is OFF before proceeding with the procedure.)

Using a flatblade screwdriver, remove the 1A fuse from the central one of the three fuse holders. If the fuse had burnt out, install the attached 1A fuse, and turn ON the power switch to actuate the ultrasonic oscillator.

If the fuse has not burnt out, install it as it was. Then check the right-hand adjacent 2A fuse (in the power receiving circuit) and the left-hand adjacent 2A fuse (in the power circuit for the ultrasonic vibrator), similarly.

## 5. Troubleshooting

If ultrasonic cleaning yields unfavorable results, make inspections first of all, referring to Chapter 4 in this manual. This chapter describes remedies for malfunctions of the ultrasonic oscillator.



### Caution against Electric Shock

Some areas in the electric circuits in the PUS400G ultrasonic oscillator remain carrying high voltage for a while (approx. 10 minutes) even after the power switch is turned OFF.

In inspecting the electric circuits, allow a sufficient period of time before removing the panel.

Repair to faults in the electric circuits should be consult with YOKOGAWA.

## 5.1 Remedies for Troubles

If any trouble is encountered, promptly try to find the cause and remedy it.

### 5.1.1 Troubles and Possible Causes

Table 5.1 lists troubles that may be encountered and their causes.

**Table 5.1 Troubles and Causes**

Trouble	Possible cause
No ultrasonic wave is generated from ultrasonic vibrator.	Defect in ultrasonic vibrator (Refer to Subsection 5.2.1.) Fault in ultrasonic oscillator (Refer to Subsection 5.2.3.)
Frequent burnout of fuses	Abnormally in equipment (*)
In-action pilot lamp lighting does not come back.	Defect in ultrasonic vibrator (disconnection in connecting wires)
Degraded cleaning results	Supply voltage drop (Refer to Subsection 5.1.2.) Abnormally in ultrasonic vibrator (*)

\*: Consults with YOKOGAWA.

### 5.1.2 Remedy for Supply Voltage Drop

If the voltage of the power supply to the ultrasonic oscillator drops, the ultrasonic power is also reduced. If the voltage remains below the allowable range for a long time, re-connect the oscillator to another power supply with less voltage fluctuation.



## 5.2 Part Replacing Procedure

If any part should become defective, replace it with a new one.

Below is the description of procedures for replacing the ultrasonic vibrator cable and for checking (replacing) the ultrasonic vibrator.

### 5.2.1 Replacing Ultrasonic Vibrator Cable

The ultrasonic vibrator cable connected with Terminals U1, U2 and S on the ultrasonic oscillator is connected to the ultrasonic vibrator through the connectors on the pH holder. If there is any anomaly in the ultrasonic vibrator cable, it is required to replace it as an assembly containing an ultrasonic vibrator holding part. Refer to the user's manual for pH holder for details.

### 5.2.2 Inspecting and Replacing Procedures for Ultrasonic Vibrator

Refer to the instruction manual for the pH holder for the replacing procedure for the ultrasonic vibrator.

### 5.2.3 Inspection of and Repair to Ultrasonic Oscillator

The operational inspection of, and repair to, the ultrasonic oscillator call for a thorough knowledge of its electric circuits and the skill of repairing. If the ultrasonic oscillator malfunctions, request inspection or repair from YOKOGAWA.

# Customer Maintenance Parts List

## PUS400G Ultrasonic Oscillator for pH Meter

EXA PH

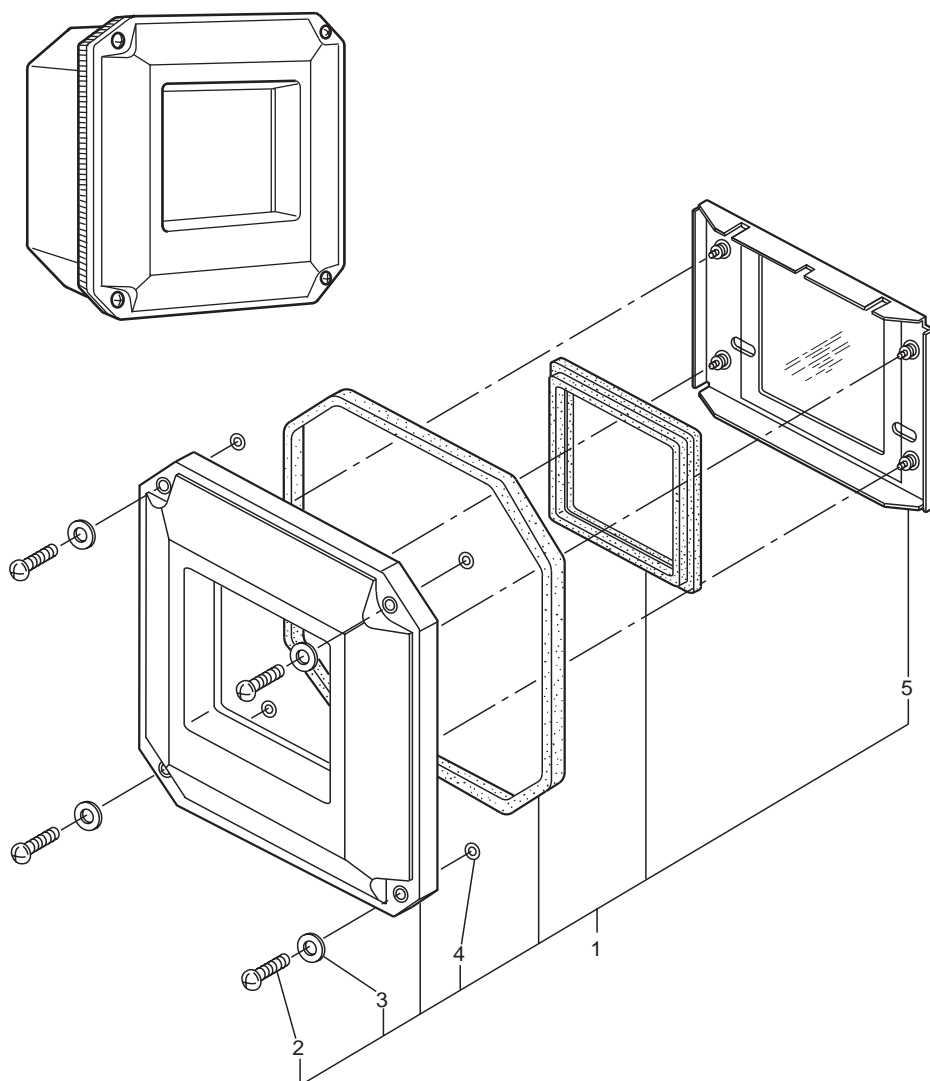

Item	Part No.	Qty	Description
1	- K9317AJ K9317BJ	1	Cover Assembly (Coating : Baked polyurethane resin) (Coating : Baked epoxy resin)
2	Y9520JU	4	Pan H. Screw, M5×20
3	Y9500WU	4	Washer
4	Y9102XA	4	O-ring
5	K9311JN	1	Window Assembly

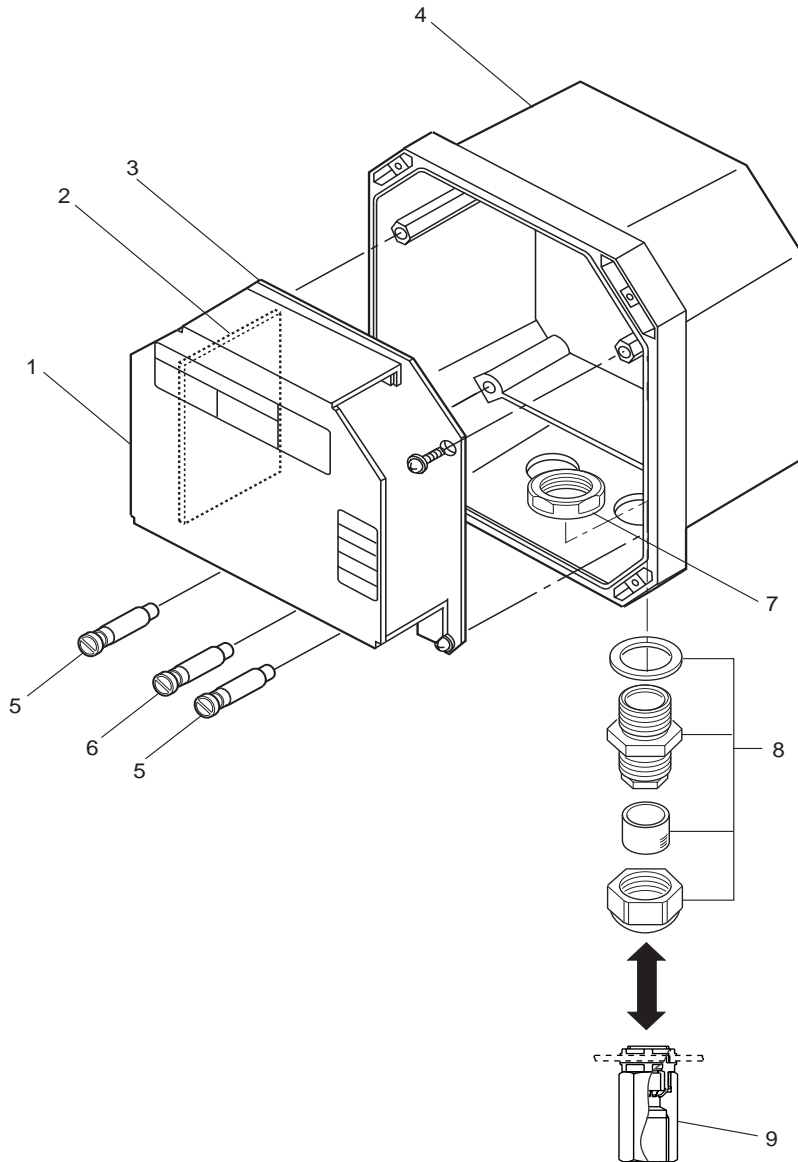

Item	Part No.	Qty	Description
1	K9317AA	1	Panel Assembly
2	K9317EA	1	Timer Board Assembly
3	-	1	Power Board Assembly
	K9317EH		(For 100 V AC Power Supply)
	K9317EJ		(For 110 V AC Power Supply)
	K9317EK		(For 115 V AC Power Supply)
	K9317EL		(For 200 V AC Power Supply)
	K9317EM		(For 220 V AC Power Supply)
	K9317EN		(For 240 V AC Power Supply)
4	-	1	Case Assembly
	K9317AQ		(Coating : Baked polyurethane resin)
	K9317BQ		(Coating : Baked epoxy resin)
5	A1111EF	2	Fuse (2 A)
6	A1109EF	1	Fuse (1 A)
7	L9811FK	2	Nut
8	L9811FT	2	Cable Gland
9	-	1	Adapter Assembly
	K9317AF		(For G1/2 screw; option code : /AFTG)
	K9317AG		(For 1/2NPT screw; option code : /ANSI)

## SUNSHADE HOOD (Optional)

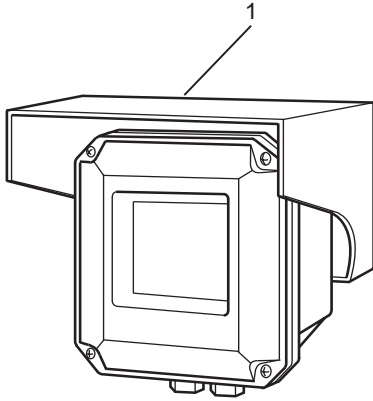

## MOUNTING BRACKET

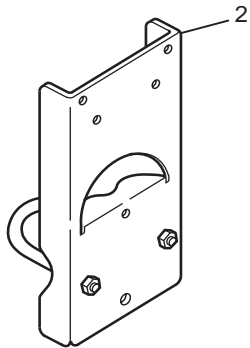

Option code : /PS

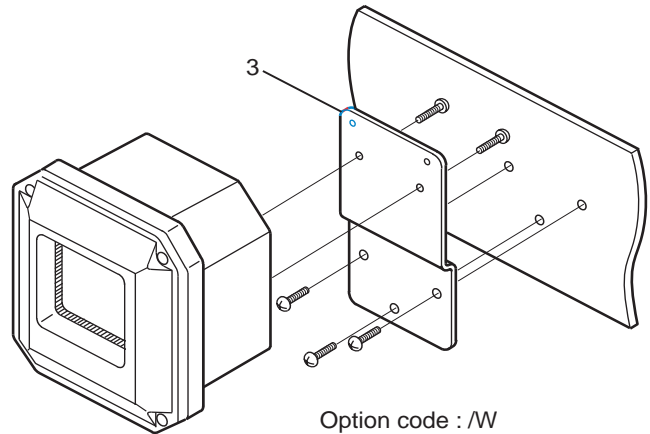

Option code : /W

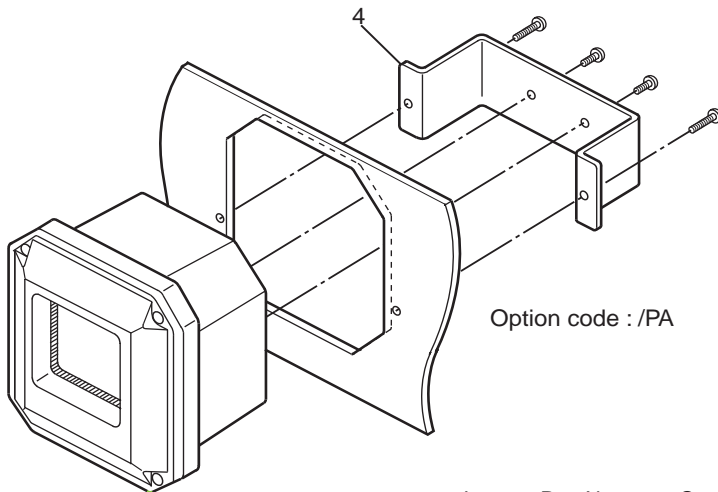

Option code : /PA

Item	Part No.	Qty	Description
1	— K9311KG K9660JA	1	Hood Assembly for /H option for /H2 option
2	K9317AY	1	Pipe Mounting Bracket Assembly
3	K9149SB	1	Wall Mounting Bracket Assembly
4	K9311KA	1	Panel Mounting Bracket Assembly



---

# Revision Information

- Title : Model PUS400G Ultrasonic Oscillator
- Manual No. : IM 19C1B3-01E

**Mar. 2014/6th Edition Addition of "For Korea (-KC)"**

1.1 Addition of specifications, 1.2 Addition of Suffix Code, 1.3 Addition of the Noise filter assembly, 2.1.2 & 2.2.4 Postscript about -KC

**Jul. 2012/5th Edition Page layout changed by InDesign**

p. 1-3, option code "/H2" (awning hood made of stainless steel) added to MS-code; p. 1-4 to 1-5, some of dimensions modified; p. 3-3, some of section 3.3 Steady State Operation modified; CMPL 19C01B03-01E revised to 5th edition.

**Jul. 2007/4th Edition IM style & Format renewed**

Revised and corrected all over ("After-Sales Warranty" added, etc.)

**Sep. 1998/3rd Edition**

Some error correction.

**Apr. 1997/2nd Edition**

Some error correction.

**Apr. 1996/1st Edition**

Newly published.

- 
- If you want to have more information about Yokogawa products, you can visit Yokogawa's home page at the following web site.  
Home page: <http://www.yokogawa.com/an>
-

