



**LRB 6000CI**  
**LASER RANGE FINDER**  
**BINOCULARS**



## IMPORTANT INFORMATION

### Read prior to activation

You have just purchased a sophisticated electro-optical device that emits invisible laser radiation. To operate it properly, please read this manual carefully.

- **NEVER** direct laser beam at the eyes of people or animals
- **NEVER** aim the unit at the Sun or bright sources of light
- **NEVER** subject the unit to impacts
- **NEVER** transport the unit without its case
- **NEVER** disassemble the unit. This may be hazardous for you due to high voltage currents in the system
- **ALWAYS** keep the unit out of children's reach
- **ALWAYS** remove the battery when the device is not in use for a long period
- **ALWAYS** store in a dry place
- **Caution** - use of controls or adjustments, or performance of procedures other than those specified herein may result in hazardous radiation exposure
- **Caution** - use of optical instruments such as binoculars, loupes, mirrors, lenses, etc. with this product increases eye hazard
- **Note:** Avoid eye exposure to direct laser beam or its close reflection
- **Prevent** bright light from focusing through the eyepieces

## **TABLE OF CONTENTS**

1. BRIEF DESCRIPTION.....	2
2. DEVICE APPEARANCE .....	3
3. DELIVERY SET.....	4
4. SPECIFICATIONS .....	5
5. OPERATION INSTRUCTIONS .....	6
Installing the battery.....	6
Using the Device.....	7
Factors affecting measuring distance .....	7
Target selection logic .....	8
Operation and service modes .....	8
Compass calibration .....	9
Setting interface format.....	10
Gating mode.....	10
Data Recall mode .....	11
Computer interconnectivity.....	11
GPS interconnectivity .....	12
Short mode switching scheme.....	12
6. BEST MEASURING TECHNIQUE.....	13
7. STORAGE AND MAINTENANCE.....	13
8. TROUBLESHOOTING .....	14
9. WARRANTY .....	14
10. CUSTOMER SUPPORT.....	15
11. QUALITY CERTIFICATE.....	16

**CAREFULLY READ ALL THE INSTRUCTIONS PRIOR TO  
USE!**

**FAILURE TO OBEY THE INSTRUCTIONS WILL VOID THE  
WARRANTY AND MAY CAUSE INJURY!**

## **1. BRIEF DESCRIPTION**

**LRB 6000CI Laser Rangefinder Binoculars** (System) is an advanced laser range finder system that enables instant distance, speed, vertical and horizontal angular measurements. An outstanding optics provides a sharp, clear image under any observation conditions.

The unit utilises time-of-flight method of distance and speed measurement. The System sends invisible, eye safe laser pulses to the target. The returned pulses are captured by the digital circuitry. The time difference is used to calculate the distance to the target. A built-in digital compass measures an angle between the optical axis and direction to the magnetic North Pole.

The unit complies with CFR 21, Part 1040.10 and Part 1040.11.

A built-in inclinometer allows elevation angle measurements and height (depth) calculations.

### **Key Features of the LRB 6000CI Laser Rangefinder Binoculars**

- Modern digital circuitry allows targeting through most types of glass
- First, last or the most reflective target acquisition
- Meters/Yards/Mils/Degrees/KMH/MPH display
- Last 10 measurements recall
- Selectable reticle shape (+ or □ )
- Gating capability
- Speed detector
- Accurate digital compass
- Accurate digital inclinometer
- RS-232 bidirectional communication
- GPS interoperability (PLGR/DAGR protocol)

## 2. DEVICE APPEARANCE

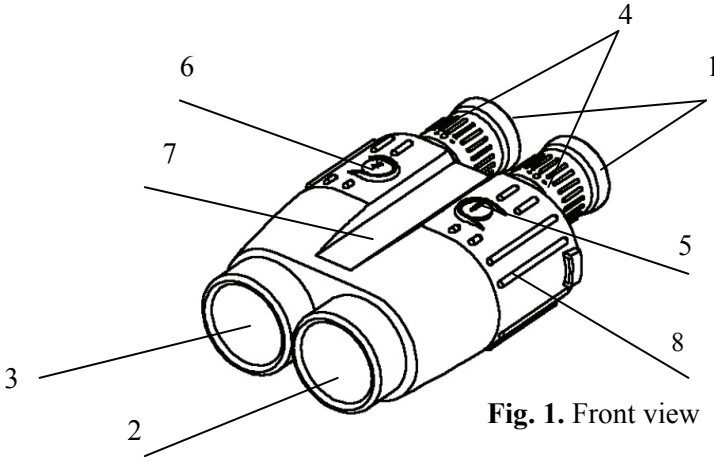

**Fig. 1. Front view**

- |                               |                                |
|-------------------------------|--------------------------------|
| 1 – Eyepieces                 | 2 – Objective / receiving lens |
| 3 – Objective / emitting lens | 4 – Dioptic adjustment rings   |
| 5 – Mode button               | 6 – Action button              |
| 7 – Body of the device        | 8 – Rubber grip                |

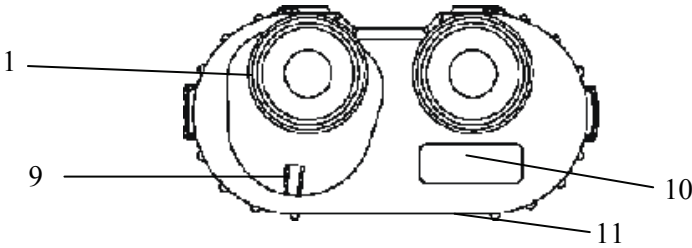

**Fig. 2 Rear view**

- |  |
|--|
| 1 – Eyepiece   |
| 9 – Interpupillary distance adjustment lever                 |
| 10 – Model Identification label                              |
| 11 – Identification and certification label (at the bottom): |



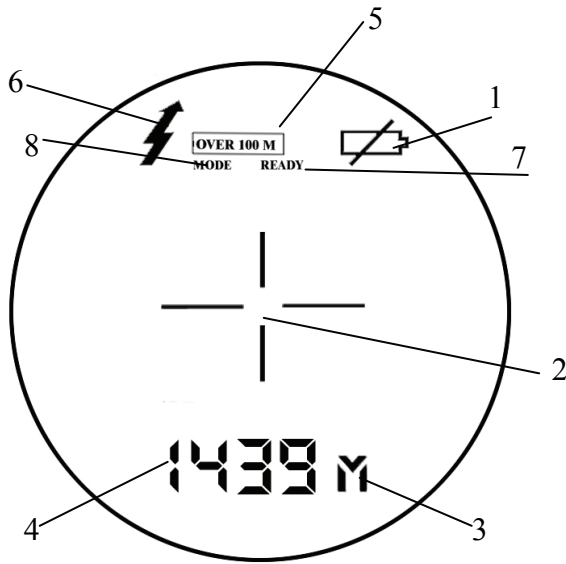

**Fig. 3** Display

- |                           |  |
|---------------------------|--|
| 1 – Low battery indicator | 2 – Reticle (either $\text{--- }$ or $\square$ ) |
| 3 – Units of measurement  | 4 – Measurement result                           |
| 5 – Gating indicator      | 6 – Laser active indicator                       |
| 7 – Ready mode indicator  | 8 – Setup mode indicator                         |

### 3. DELIVERY SET

Standard delivery set for LRB 6000CI includes:

	Qty
LRB 6000CI	1 pc.
Carrying case	1 pc.
Neck strap	1 pc.
User's manual	1 pc.
Warranty card	1 pc.
Computer cable	1 pc.
CD with communication software	1 pc.
Hard case	1 pc.
9V non-magnetic Lithium battery	1 pc.

## Optional items

- Remote control module
- GPS cable

Exact delivery set depends on details of a contract or purchase order.

## 4. SPECIFICATIONS

### Optics

Magnification	7x
Objective lens diameter	50 mm
Exit pupil diameter	7.1 mm
Field of view	7°
Type of coating	Fully multi-coated optics
Interpupillary distance	58-72 mm
Dioptre adjustment range	±4

### Range Finder

Laser	Class 1, eye safe, 905 nm
Measuring range	1 – 6,500 m
Accuracy and display resolution	±1 m
First, last and auto target selection	Yes
Meters / Yards display	Yes
Last 10 measurements recall	Yes
Reticle	⊕ or □
Target quality indicator	Yes
Gating capability	100 - 3,900 m; 100 m step

### Speed Detection

Measured speed range	5-400 km/h or 3-250 mph
Accuracy	± 1 km/h or mph

### Compass

Measured azimuth range	6400 mils /360°
Accuracy	±1°



## **Inclinometer**

Measured elevation range	±60°
Accuracy	±1°
Height measuring	Yes (Meters or Yards)

## **Power**

Battery	9V Lithium (non-magnetic)
Battery capacity	Min 4,000 measurements (Scanning regime)
'Low Battery' indicator	Yes

## **Environmental**

Operational temperature range	-40...+55°C (-40...+131°F)
Storage temperature range	-45...+65°C (-49...+149°F)

## **Mechanics**

Tripod thread	¼" x 20 TPI
Weight without battery	1.3kg
Weight with hard case	3.5 kg
Dimensions	210x150x60 mm

# **5. OPERATION INSTRUCTIONS**

## **Installing the battery**

- Open the battery compartment using a suitable tool, or a coin. Insert a 9V Lithium non-magnetic battery provided with your device
- Connect the battery to the battery snap
- Refit the battery compartment and tighten the screw.

If the battery compartment cover does not close tightly and evenly, check that the battery snap wires are neatly packed inside the battery compartment and the cover is aligned over the edge of the battery compartment.

**Note:** Battery in metal casing will diminish compass accuracy. Non-magnetic batteries should be used for the utmost compass performance. LRB 6000CI is equipped with battery monitoring sensor. If display shows “**LOW BATTERY**” warning when battery voltage falls below

6.5V this indicates that the battery is used up. You can still get readings, but the battery needs to be replaced soon.

### **Using the Device**

The LRB 6000CI operational procedures are design to allow the user to use most applicable options in the fastest time possible. To activate it, press and hold Action button (6, Fig.1) for one second. At start the unit comes into Ready to Measure mode indicated by the word 'READY' on the display visible through the eyepiece.

Pressing Action button (6, Fig. 1) again will initiate measurement procedure. The results of measurement are displayed in default form of "Distance (M), Azimuth (mils) and Elevation (mils)" measurement parameters also can be modified to user preference (see Setup Mode).

If results of measurement are unreliable four dashes ('----') will be displayed in the area (4, Fig. 3).

Pressing Mode button (5, Fig. 1) gives the user the options to change settings from Factory default to specific modes required by user. For full list of Mode options please refer to Operation and Service modes

If the target is located below the unit the result of vertical measurement (elevation or height) will be preceded with minus ("-") sign.

### **Factors affecting measuring distance**

Target reflectivity depends on its color, surface finish, size, shape, position in relation to the laser beam, etc. Bright target colors are more reflective than darks. A polished surface is more reflective than a rough one. Larger targets reflect better than small ones. Ranging a target perpendicular to the laser beam provides better results than the one positioned at a sharp angle to the beam.

Weather conditions that influence air transparency (rain, fog, snow, mist) reduce maximum range. Bright sunny days will reduce performance as well as IR sun radiation may cover reflected laser impulses.

While the unit will measure through many glass types, measuring through glass may reduce accuracy.

Natural hand tremor decreases the accuracy of long distance ranging. Using of a tripod is highly recommended.

Note: device may produce false readings when reticle is aimed at the sun or in  $\pm 20^\circ$  solid angle from the sun.

## Target selection logic

On its way towards the target the laser beam may be reflected from various objects, thus decreasing ranging accuracy. The smaller, the farther, and the less reflective is the target – the higher is the possibility of obtaining an incorrect measurement.

To improve accuracy the unit has a built-in target selection logic that allows user the option of choosing which target to range: the nearest ('first'), the farthest ('last'), or the most reflective ('auto').

This mechanism helps selecting the target when ranging from behind the bushes, wires, through the falling snow, or in similar conditions.

Furthermore, it enables ranging a target in front of a bigger object, such as a wire in front of the wall.

**Note:** Even with target selection logic the unit may not always be able to range the desired target as its reflectivity may be too low to produce enough laser beam reflections for statistically reliable calculation.

Individual Measurement and Scanning regimes

The unit can operate in two methods: (1) *Individual Measurement* and (2) *Scanning*. In *Individual Measurement* method the unit performs single measurement when Action button is pressed shortly, in *Scanning* regime the unit repeatedly measures and displays results every second while A button is pressed.

To activate *Scanning* regime press and hold Action button in Ready mode. The unit will work in *Scanning* regime while Action button is pressed.

*Scanning* or *Individual Measurement* regimes are available for any selected mode of measurement. When two or more parameters are measured in *Scanning* regime though first result will be displayed, the second and other results will be shown at the display if Action button is released. Nevertheless all data is transferred to the PC and recorded in internal memory, and may be recalled (see *Data Recall mode* for details.)

## Operation and service modes

Pressing Mode button (5, Fig.1) in *Ready* mode switches the unit between modes of operation, to activate any desired mode from the menu you must confirm your selection by pressing Action button (6, Fig.1)

The unit has the following modes of operation:

- **Ready** – Unit is ready to perform measurements
- **dFLt** – sets default mode of operation with factory settings,
- **GAtE** – allows to set gating distance for measurement

- **Std** – allows the user to select single action measurements:
  - Distance only
  - Compass Only
  - Elevation Only
  - Speed Only
  - Height Only
  - Speed + Distance
  - Distance +Compass + Elevation
- **Unit** – allows the user to select units of desired measurements,
  - Distance from M to Y
  - Compass & Elevation from Mils to Degrees
  - Speed from KMH to MPH\*

\*note this option is only available if **Std** Speed is selected
- **rEc** – allows data recall of the last 10 measurement results,
  - **CLr** – Clears all Measurement
- **SEt** – allows the user to select the following advanced options:
  - **FrSt** – First Target Measurement
  - **LASt** – Last Target Measurement
  - **PLGr** – Communication to PLGR GPS\*
  - **PC** – Communication to PC\*
  - **Reticule** – Change reticule from + (cross) to □ (rectangle)
  - **CAL** – Compass calibration

\*not shown in the menu if currently selected

### Compass calibration

If the System was exposed to a strong magnetic field or was not in use for a long time, the compass accuracy may diminish.

To return the compass into working condition:

- Select **Cal** from **SEt** menu

- Keeping the unit horizontally, perform one full rotation around vertical axis within half a minute and then one full rotation around vertical axis with device upside down during half a minute.
- If one rotation does not restore calibration – perform two rotations. The normal compass functioning will be restored.

### Setting interface format

In this mode data communication standard is set. The unit can output measurement data via RS-232 port in either PC format (description of the proprietary format can be obtained from Newcon upon a request) or in the format accepted by PLGF/DALGR.

To select required data format:

- Select **PLGr** or PC from **SEt** menu
- Pressing Action button will activate PC or PLGR format, the display name of format that can be activated will be shown.

### Gating mode

In this mode gating function is activated: here user can set the minimal distance to the target, any object closer than the gating distance will be ignored.

To select Gating Mode:

- Select **GAtE** from `mode` menu

Minimal gating distance of 000 m will be initially set, further pressing M button will increase gating distance by 100 m up to 3,900 m. When the desired distance is reached – select it by pressing **Action** button.

**OVER 100M** – indicates that gating is active

To deactivate gating choose gating value zero.

**Note:** The gating distance can only be increased. To exit the gating selection cycle without setting any gating distance click through full gating range with **M** button or hold **M** button for 2 seconds.

Gating feature helps measuring remote targets in unfavourable atmospheric and environmental conditions by eliminating reflections from snowflakes, raindrops, industrial wires, tree branches, etc. At the same time, if gating distance is set incorrectly, you can remove the desirable object from measurement range.

## Data Recall mode

In *Data Recall* mode results of the last 10 measurements can be displayed.

Measurement results are saved in on-board memory in sets depending on the parameters set for measuring, for instance, if only distance is measured - the set will consist of one number, if distance and azimuth are measured – the set will consist of two numbers.

To enter *Data Recall* mode select **rEc** from `mode` menu. First measurement set number (display name: **rEc 1**) will start flashing.

Pressing M button moves the unit along the list of measurement set numbers and measurement results:

**rEc 1**, distance 1, azimuth 1, elevation 1,  
**rEc 2**, distance 2, azimuth 2, elevation 1, ...,  
**rEc 0**, distance 0, azimuth 0, elevation 0.

Measurement sets are numbered in reverse order: first recalled set is the result of the last measurement. If any parameter has not been actually measured it will not be recalled.

Pressing A button at any moment within the list of recalled results brings the unit to *Ready to Measure* mode.

Choosing **cLr** at the end of recalled data will erase the device memory.

## Computer interconnectivity

The unit supports RS-232 interface. Physical connection is performed through connector with threaded coupling mechanism, designed for the heavy-duty outdoor applications.

**Note:** Do not apply excessive force when disconnecting cable. Damage to cable or connector resulting from improper treatment is not covered by warranty.

To attach the cable to the rangefinder match the key on the plug (1, Fig. 5) with the corresponding key on the socket and then push gently the plug holding it by its casing (3, Fig. 5) until click.

To detach the cable slide sleeve (2, Fig. 5) away from the unit and pull the plug out.

The communication port must be initiated prior to connecting the unit to the computer. The data is transmitted as hex string code with fixed baud rate of 38400 bit/sec, 8 bits, one stop bit, and no parity.

This connector is IP67 graded.

## **GPS interconnectivity**

LRB 6000CI can transmit the acquired data to a GPS receiver using DB15 connector and PLGR/DAGR protocol. An optional cable is required.

To work with GPS, perform the following steps:

- Switch the rangefinder to **PLGr** mode;
- Choose **dFLt** measuring mode;
- Connect the rangefinder and GPS unit with the cable.

For each measurement GPS will display the absolute coordinates of your target.

**Note:** If the rangefinder is not set initially to **dFLt** mode, the GPS will not operate properly.

**Note:** GPS unit automatically adjusts coordinates to reflect actual magnetic declination. Therefore, coordinates displayed on the GPS may differ from those calculated by the computer.

## **Short mode switching scheme**

Upon request, your LRB 6000CI rangefinder may be manufactured with reduced functionality. This version is easier to use, and it is beneficial for users planning to work with GPS only. The short mode switching scheme does not transmit data in PC software format.

**Note:** The rangefinder can be programmed for the short or full mode switching scheme at the factory only.

## 6. BEST MEASURING TECHNIQUE

Laser range finder measures distance by catching laser beam reflected from the target. Everything that improves reflection increases the measurement reliability and maximum range.

1. Use tripod when ranging remote targets. The longer is the distance, the greater is the beam shift due to hand tremor.
2. Aim at a surface on the target that is the closest to perpendicular to the laser beam. The closer you get – the stronger will be the reflection.
3. The unit deploys sophisticated software that tries to understand which target you are aiming at. However, due to beam divergence several objects may produce a strong reflection. To help the System recognise the target the *Target Selection Logic* may be used. For example, if ranging a wire in front of a building, selecting the “first” target (Code 12) will produce a more reliable result. Alternatively, when aiming at a chimney behind the trees, selecting “last” target (Code 11) will be better. By default the System assumes “auto” target selection, that is, the object producing the most reflections will be considered a target.
4. Another way to improve reliability of measurement is to use gating mechanism. If gating is active reflections from all objects closer than the gating distance will be ignored. This is especially effective when ranging in unfavourable atmospheric conditions, that is, in the rain, fog, haze or in the bright sun. Gating provides better results than the “last” target selection, but it requires preliminary rough distance estimation to cut off all objects closer than the chosen one.

**Note:** Gating setting is remembered by the System until altered.

Therefore, if you forget to turn the gating off, the next time you start measuring it can ignore the desired object, if it is closer than the gating distance. The unit will display four dashes instead of the measurement results. “Over 100 meters” display indicator shows active gating.

## 7. STORAGE AND MAINTENANCE

The unit is a sophisticated precision optical instrument equipped with laser and electronics. Therefore, it should be handled with due care.

- Keep away from direct sunlight.
- Avoid impacts, jolts, dust, moisture, and sharp changes of temperature.
- Do not use the device at temperatures higher than 50°C (122°F).



- Do not touch optical surfaces. Doing so may damage the anti-reflection coating.
- Clean optical surfaces only with professional camera lens cleaning supplies.
- Clean the exterior of the unit with a soft clean cloth.
- Keep the unit away from heating appliances and central heating.
- Remove the battery when storing the device for long time.
- All repair works must be performed by an authorized service.

## 8. TROUBLESHOOTING

***Ranging does not work. The display is transparent.***

Check the charge of the battery. Replace it if it is weak.

***Ranging does not work. The display indicates results of the last measurement.***

Wait for 8 seconds until the display becomes transparent, and press the Action button again.

***Black dots are visible on LCD.***

Liquid Crystal Display may have small black dots, scratches and other blemishes inherited from the manufacturing process. These flaws are strictly regulated by number, area and location and do not degrade the product's measurement capabilities.

***Range measurement cannot be obtained.***

- Make sure that neither your hand nor finger is blocking objective lens, laser emitting lens or receiver lens.
- Hold the unit firmly (avoid hand tremor) while pressing the Action button.
- Check that the target is within measuring range of the device and the gating mode does not cut it off.

## 9. WARRANTY

NEWCON warrants this product against defects in material and workmanship for one year from the date of the original purchase, but no more than 18 months from the date of manufacturing. Longer warranty is available, subject to the terms of the specific sales contract. Should your Newcon product prove to be defective during this period, please deliver the product securely packaged in its original container or an equivalent,

along with the proof of the original purchase date to your Newcon Dealer.

Newcon will repair (or at its option replace with the same or comparable model), the product or part thereof, which, on inspection by Newcon, is found to be defective in materials or workmanship.

***What This Warranty Does Not Cover:***

NEWCON is not responsible for warranty service should the product fail as a result of improper maintenance, misuse, abuse, improper installation, neglect, damage caused by disasters such as fire, flooding, lightning, improper power supply, or service other than by a NEWCON Authorized Service.

Postage, insurance, and shipping costs incurred while presenting your NEWCON product for warranty service are your responsibility.

If shipping from North America please include a cheque or money order payable to NEWCON OPTIK for the amount of US\$15.00 to cover handling and return shipping.

## **10. CUSTOMER SUPPORT**

Should you experience any difficulties with your NEWCON OPTIK product, consult the enclosed manual. If the problem remains unresolved, contact our customer support department at (416) 663-6963 or toll free at 1-877-368-6666. Our operating hours are 9am-5pm, Monday - Friday, Eastern Standard Time. At no time should equipment be sent back to Newcon without following the instructions of our technical support department.

NEWCON OPTIK accepts no responsibility for unauthorized returns.

To locate NEWCON Authorized Dealer call:

Tel: (416) 663-6963 Fax: (416) 663-9065

Email: [newconsales@newcon-optik.com](mailto:newconsales@newcon-optik.com)

Web: [www.newcon-optik.com](http://www.newcon-optik.com)

The defective products should be shipped to:

**US customers:**

2331 Superior Ave. Cleveland, OH 44114

**all other countries:**

105 Sparks Ave., Toronto, ON

M2H 2S5, CANADA

# 11. QUALITY CERTIFICATE

Serial number \_\_\_\_\_

The unit indicated above has passed the quality inspection.

Production date \_\_\_\_\_

Quality Inspector \_\_\_\_\_

Purchase date \_\_\_\_\_

