



ASSEMBLY, INSTALLATION, AND REMOVAL OF CONTACTS AND MODULES

FOR 20/26 GHz COAXIAL CONTACTS AND MODULES

Table of Contents

SECTION 1 RECEIVER CONTACT ASSEMBLY INSTRUCTIONS

SECTION 2 ITA CONTACT ASSEMBLY INSTRUCTIONS

SECTION 3 CONTACT INSTALLATION AND REMOVAL INSTRUCTIONS

SECTION 4 MODULE INSTALLATION AND REMOVAL INSTRUCTIONS

SECTION 5 CROSS REFERENCE TABLES

SECTION 6 PRODUCT PERFORMANCE SPECIFICATIONS

20/26 GHz COAXIAL RECEIVER CONTACT ASSEMBLY

PART # 610 102 109 FOR STRIPFLEX 142B, OR M17/60-RG142

610 102 116 FOR M17/84 RG-223



TOOLS REQUIRED

Crimp Tool, Part # 910 101 124

Dimensions shown: [millimeters]
inches

ASSEMBLY INSTRUCTIONS

- Strip wire and point center conductor (**Figure A**).
- Slide crimp ring over wire and flair braid by rotating dielectric (**Figure B**).
NOTE: Remove mylar foil on stripflex 142 cable.
- Insert the barrel of the threaded crimp nut between the braid and dielectric, positioned so that the end of the cable dielectric is flush with the end of the threaded crimp nut (**Figure C**).
- Using the Crimp Tool, Part # 910 101 124 (**Figure D**), slide the crimp ring against the shoulder of the threaded crimp nut and crimp using the larger hex position (**Figure E**).
- Install and tighten the shield conductor assembly to 7-10 in-lbs [0.79-1.13 Nm] (**Figure F**).
- Apply ¼" [6.4 mm] diameter 1" [25.4 mm] long shrink tubing over crimp ring up to shoulder of threaded crimp nut and shrink (**Figure G**).

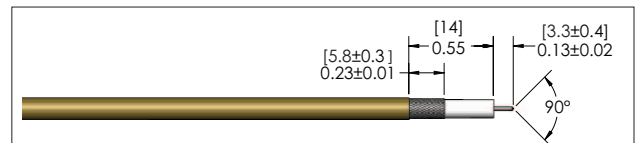

Figure A. Strip lengths.

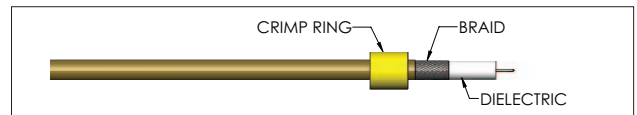

Figure B. Apply crimp ring.



Figure C. Apply threaded crimp nut; ensure the end of the dielectric is flush with the end of the threaded crimp nut.



Figure D. Crimp Tool, Part # 910 101 124.



Figure E. Crimp crimp ring.



Figure F. Apply shield conductor assembly.

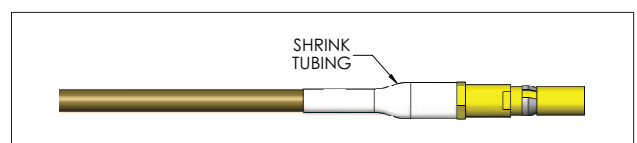

Figure G. Apply shrink tubing.

*It is recommended to use the following cables to achieve certain frequencies:

Stripflex™ 142B	26 GHz
M17/84-RG223	12.4 GHz
M17/60-RG142	8 GHz

20/26 GHZ COAXIAL ITA CONTACT ASSEMBLY

PART # 610 102 110 FOR STRIPFLEX 142B OR M17/60-RG142

610 102 117 FOR M17/84-RG223



TOOLS REQUIRED

Crimp Tool, Part # 910 101 124

Dimensions shown: [millimeters]
inches

ASSEMBLY INSTRUCTIONS

- Strip wire and point center conductor (**Figure A**).
- Slide crimp ring over wire and flair braid by rotating dielectric (**Figure B**).
NOTE: Remove mylar foil on striptflex 142 cable.
- Insert the barrel of the threaded crimp nut between the braid and dielectric, positioned so that the end of the cable dielectric is flush with the end of the threaded crimp nut (**Figure C**).
- Using the Crimp Tool, Part # 910 101 124 (**Figure D**), slide the crimp ring against the shoulder of the threaded crimp nut and crimp using the larger hex position (**Figure E**).
- Install and tighten the shield conductor assembly to 7-10 in-lbs [0.79-1.13 Nm] (**Figure F**).
- Apply 1/4" [6.4 mm] diameter 1" [25.4 mm] long shrink tubing over crimp ring up to shoulder of threaded crimp nut and shrink (**Figure G**).

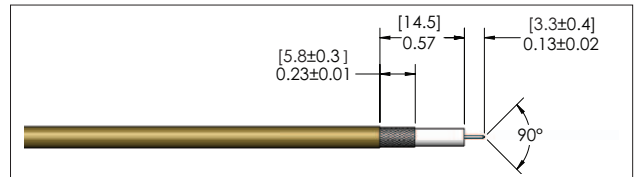

Figure A. Strip lengths.



Figure B. Apply crimp ring.

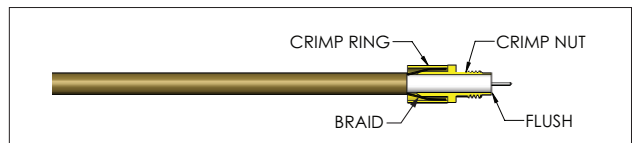

Figure C. Apply threaded crimp nut; ensure the end of the dielectric is flush with the end of the threaded crimp nut.



Figure D. Crimp Tool, Part # 910 101 124.



Figure E. Crimp crimp ring.

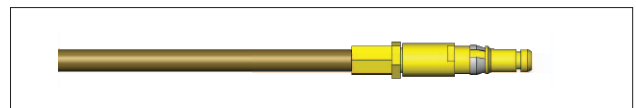

Figure F. Apply shield conductor assembly.

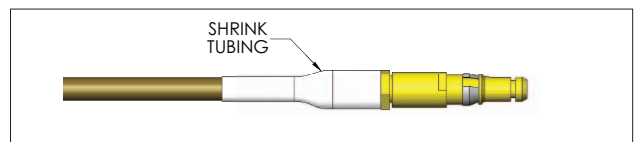

Figure G. Apply shrink tubing.

*It is recommended to use the following cables to achieve certain frequencies:

Striptflex™ 142B	26 GHz
M17/84-RG223	12.4 GHz
M17/60-RG142	8 GHz

20/26 GHZ COAXIAL RECEIVER CONTACT INSTALLATION AND REMOVAL

PART # 610 102 109 / 610 102 116 / 610 102 119

TOOLS REQUIRED

$\frac{5}{64}$ Allen wrench or Phillips screwdriver
20/26 GHz Receiver and ITA Extraction Tool, Part # 910 112 117

CONTACT INSTALLATION INSTRUCTIONS

1. Assemble the contact to the respective wire.
NOTE: For more information concerning the process of crimping the contact please see contact assembly instructions in Section 1 of this User's Manual.
2. Insert the tip of the contact into the module. Before completely inserting the contact, make sure the opening on the retaining ring is underneath the contact. This will cause the retaining ring to center around the contact.
3. Center the retaining ring's leading edge and insert the contact.
4. As you press in and meet resistance, gently wiggle the contact in an approximate circular motion while pressing in. Once in place, pull the wire slightly to ensure the contact is seated.

CONTACT REMOVAL INSTRUCTIONS

1. Remove the module from the receiver frame.
NOTE: For more information concerning the process of removing the module from the receiver frame, see module installation and removal instructions in Section 4 of this User's Manual.
2. Use a $\frac{5}{64}$ Allen wrench or Phillips screwdriver to remove the two 2-56 screws located at the top and bottom of the module.
3. Grasp the module halves and apply force in opposite directions, rocking the ends of the module while slightly pulling the top of the module away from the mating bottom section, until separated. Be sure to open both sides of the module simultaneously or contacts could be damaged.
4. Place the 20/26 GHz Receiver/ITA Extraction Tool, Part # 910 112 117 (**Figures A/B**), over the contact to be removed/replaced. Use care to keep the tool perpendicular to the surface of the module, otherwise the tool or the contact could be bent.
5. Once the extraction tool is seated and the retaining ring on the contact are compressed, push the plunger. The contact will be pushed out of the rear of the module.



DO NOT DEPRESS THE PLUNGER ON THE BACK OF THE EXTRACTION TOOL UNTIL THE TIP OF THE EXTRACTION TOOL HAS BEEN FULLY SEATED INTO THE MODULE AND COMPRESSED THE RETAINING RING ON THE CONTACT, OTHERWISE THE RETAINING RING COULD BE DAMAGED.

6. Replace the module cap using both hands to push the separated halves together. Replace and tighten the module retaining screws to a maximum torque of 2 in-lbs [0.23 Nm].

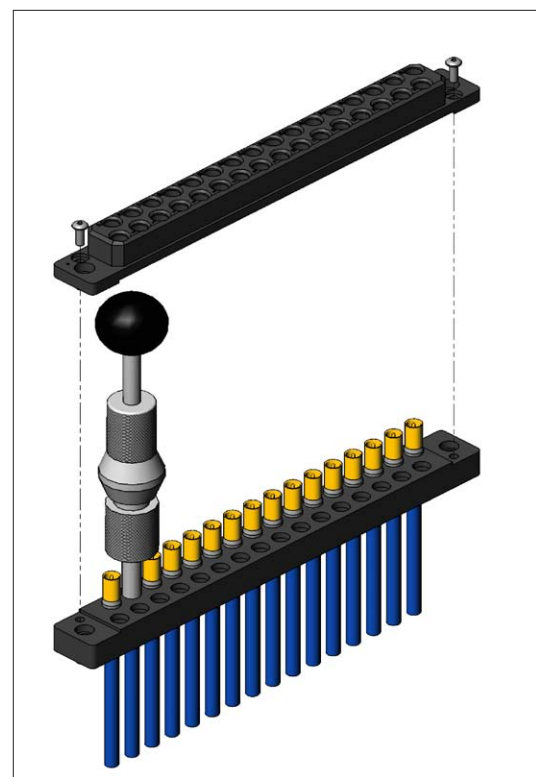

Figure A. Extraction Tool, Part # 910 112 117.

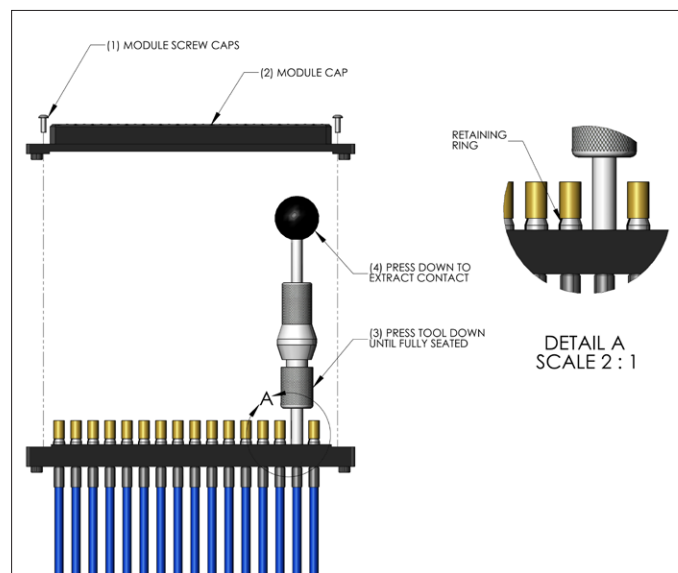

Figure B. Fully seat the extraction tool before depressing.

NOTE: The process shown here uses standard/90 series modules. The same process is used for modules from other series.

NOTE: If you are using a hybrid module, you may need to reference the User's Manual for the other contact type for extraction instructions.

20/26 GHZ COAXIAL ITA CONTACT INSTALLATION AND REMOVAL

PART # 610 102 110 / 610 102 117 / 610 102 118

TOOLS REQUIRED

20/26 GHz Coax Receiver/ITA Extraction Tool, Part # 910 112 117

CONTACT INSTALLATION INSTRUCTIONS

1. Assemble the contact to the respective wire.
NOTE: For more information concerning the process of crimping the contact please see contact assembly instructions in Section 2 of this User's Manual.
2. Insert the tip of the contact into the module. Before completely inserting the contact, make sure the opening on the retaining ring is underneath the contact. This will cause the retaining ring to center around the contact.
3. Center the retaining ring's leading edge and insert the contact.
4. As you press in and meet resistance, gently wiggle the contact in an approximate circular motion while pressing in. Once in place, pull the wire slightly to ensure the contact is seated.

CONTACT REMOVAL INSTRUCTIONS

1. Remove the module from the ITA frame.
NOTE: For more information concerning the process of removing the module from the ITA frame, see module installation and removal instructions in Section 5 of this User's Manual.
2. Place the 20/26 GHz Receiver/ITA Extraction Tool, Part # 910 112 117 (**Figures A/B**), over the contact to be removed/replaced. Use care to keep the tool perpendicular to the surface of the module as not to bend the tool or the contact to be removed. Rotate the tool slightly while pushing it into the counter bore on the mating side of the module.
3. Once the extraction tool is seated properly and the tabs on the retaining ring are compressed, push the plunger. The contact will be pushed out of the rear of the module.



DO NOT DEPRESS THE PLUNGER ON THE BACK OF THE EXTRACTION TOOL UNTIL THE TIP OF THE EXTRACTION TOOL HAS BEEN FULLY SEATED INTO THE MODULE AND COMPRESSED THE RETAINING RING ON THE CONTACT, OTHERWISE THE RETAINING RING COULD BE DAMAGED.

NOTE: The process shown here uses standard/90 series modules. The same process is used for modules from other series.

NOTE: If you are using a hybrid module, you may need to reference the User's Manual for the other contact type for extraction instructions.

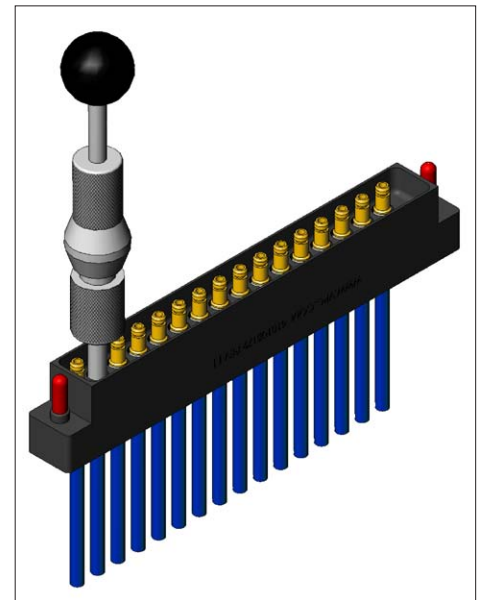

Figure A. Extraction tool, Part # 910 112 117.

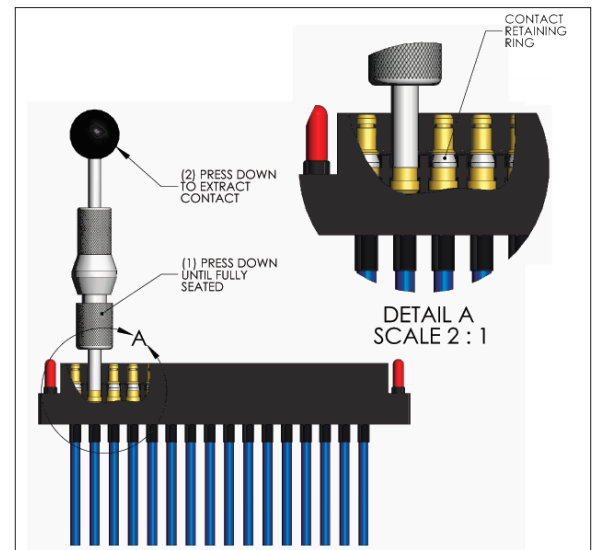

Figure B. Fully seat extraction tool before depressing.

20/26 GHZ COAXIAL STANDARD/90 SERIES MODULE INSTALLATION AND REMOVAL

TOOLS REQUIRED

$\frac{3}{32}$ Allen Wrench

INSTALLATION INSTRUCTIONS

1. Place the module in the receiver or ITA until the upper and lower module screws touch the mating holes in the inner frame. Ensure that Position 1 is located at the top for systems in which the modules are oriented vertically or to the left for systems in which the modules are oriented horizontally.
2. Using a $\frac{3}{32}$ Allen wrench, tighten the top screw 1 to 2 full revolutions, while pushing lightly against the face of the module.
3. Maintain this pressure while tightening the bottom screw 1 to 2 full revolutions.
4. Repeat this sequence until the module is seated. Torque the screw to 4 in-lbs [0.45 Nm].

REMOVAL INSTRUCTIONS

1. To remove, loosen the top screw 1 to 2 full revolutions. Loosen bottom screw 1 to 2 full revolutions.
2. Repeat this sequence until the module is separated from the receiver or ITA.

Note: For optimum performance and system longevity, distribute the contact load evenly throughout the module.

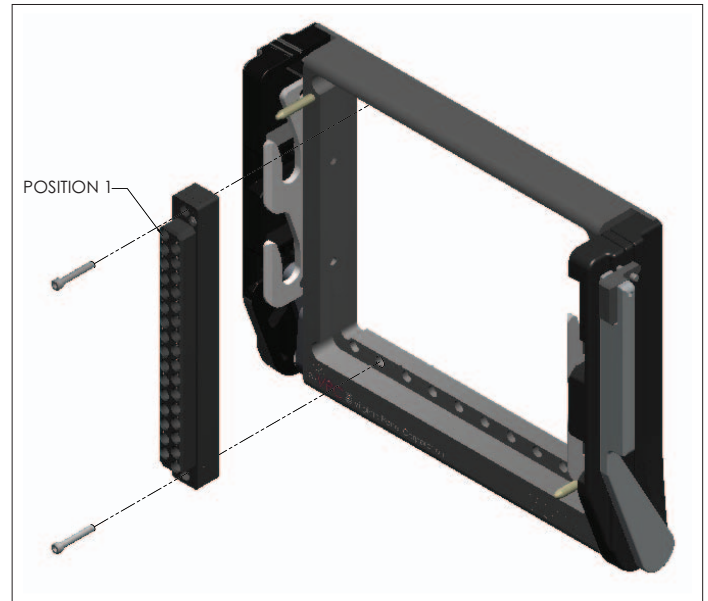

Figure A. Receiver Module.

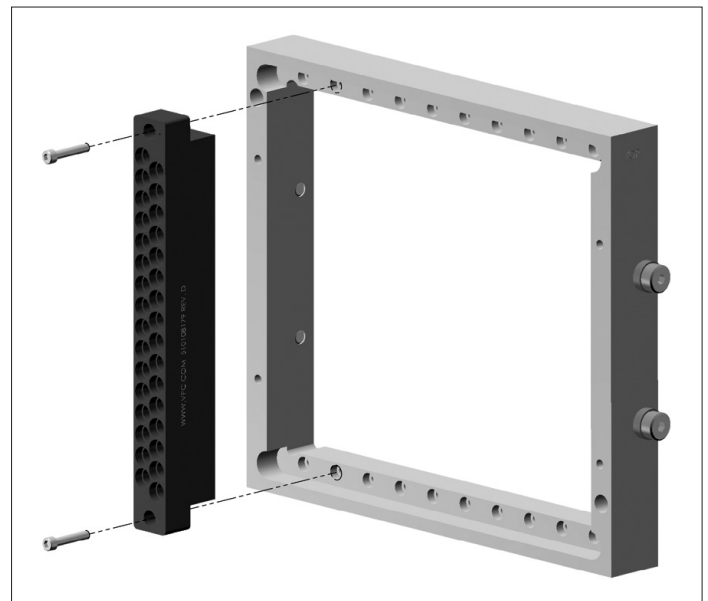

Figure B. ITA Module.

20/26 GHZ COAXIAL ICON MODULE INSTALLATION AND REMOVAL

TOOLS REQUIRED

Phillips Head Screwdriver

INSTALLATION INSTRUCTIONS

NOTE: The receiver strain relief plate or the ITA cover may need to be removed prior to installing or removing an iCon module. Please refer to the appropriate User's Manual for instructions on how to perform these steps.

1. Place the module in the receiver or ITA until the upper and lower module screws touch the mating holes in the inner frame. Install modules such that Position 1 is located at the top of the ITA/ receiver frame.
2. Using a Phillips head screwdriver, tighten the top screw 1 to 2 full revolutions, while pushing lightly against the face of the module.
3. Maintain this pressure while tightening the bottom screw 1 to 2 full revolutions.
4. Repeat this sequence until the module is seated. Torque the screw to 1.5 in-lbs [0.16 Nm].

REMOVAL INSTRUCTIONS

1. To remove, loosen the top screw 1 to 2 full revolutions. Loosen bottom screw 1 to 2 full revolutions.
2. Repeat this sequence until the module is separated from the receiver or ITA.

Note: For optimum performance and system longevity, distribute the contact load evenly throughout the module.

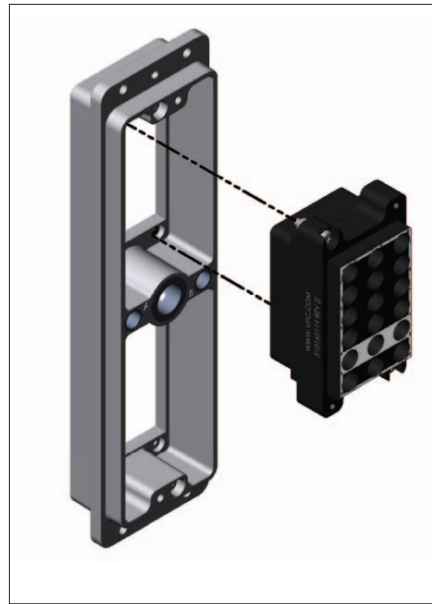

Figure A. Receiver Module.

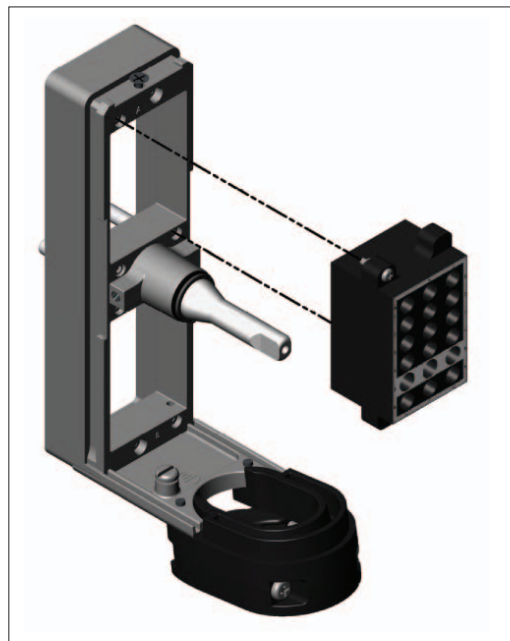

Figure B. ITA Module.

CROSS REFERENCE TABLES

RECEIVER CONTACTS	STANDARD/ 90 SERIES RECEIVER MODULE	ICON MODULES		CRIMP TOOL	EXTRACTION
	510 104 251	510 160 114	510 160 115	910 101 124	910 112 117
610 102 109	X			X	X
610 102 116	X			X	X
610 102 119	X	X	X		X

ITA CONTACTS	STANDARD/ 90 SERIES ITA MODULE	ICON MODULES		CRIMP TOOL	EXTRACTION
	510 108 179	510 161 114	510 161 115	910 101 124	910 112 117
610 102 110	X			X	X
610 102 117	X			X	X
610 102 118	X	X	X		X

20/26 GHZ CONTACT ELECTRICAL SPECIFICATIONS

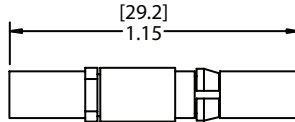

Receiver Contact
Part # 610 102 109

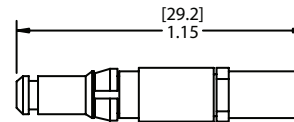

ITA Contact
Part # 610 102 110

Dimensions shown: [millimeters]
inches

Electrical Specifications

CHARACTERISTIC IMPEDANCE	50 Ohms
FREQUENCY RANGE	DC to 26 GHz
CONTACT RESISTANCE	4 mOhms Max. Center Conductor 2 mOhms Max. Shield
OPERATING VOLTAGE AND CURRENT	5 Amps DC Max. Continuous
DIELECTRIC WITHSTANDING VOLTAGE (DWV)	800 V RMS Shield to center contact 1000 V RMS
VSWR	$1.15 + 0.01(f)\text{GHz}$
INSERTION LOSS	$.06x \sqrt{f(\text{GHz})}\text{dB}$
RF LEAKAGE	-60 dB min. @ 2 - 3 GHz
RECOMMENDED TERMINATION	Cable 142, 223, 303, 400 (use SF142B to achieve 26 GHz and RG223 for 12 GHz)

Mechanical Characteristics

CYCLE LIFE	20,000
MATING FORCE	4 lbs max. [1.81 Kg]

Material

OUTER SHIELD (ITA)	Brass per ASTM - B16 Au per MIL-G-45204
OUTER SHIELD (RCVR)	Brass per ASTM - B16 Au per MIL-G-45204
CENTER CONDUCTOR (ITA)	BeCu per ASTM - B196 Au per MIL-G-45204
CENTER CONDUCTOR (RCVR)	BeCu per ASTM - B196 Au per MIL-G-45204 over Cu per MIL-C-14550
RETAINING RING	BeCu per ASTM - B196 Ni per QQN - 290
CONTACT RING (RCVR)	BeCu per ASTM - B196 Au per MIL-G-45204
DIELECTRIC	PTFE Fluorcarbon