

Series 8000WJ

Water Jacketed CO₂ Incubator

Operating and Maintenance Manual 7003422 Rev. 7

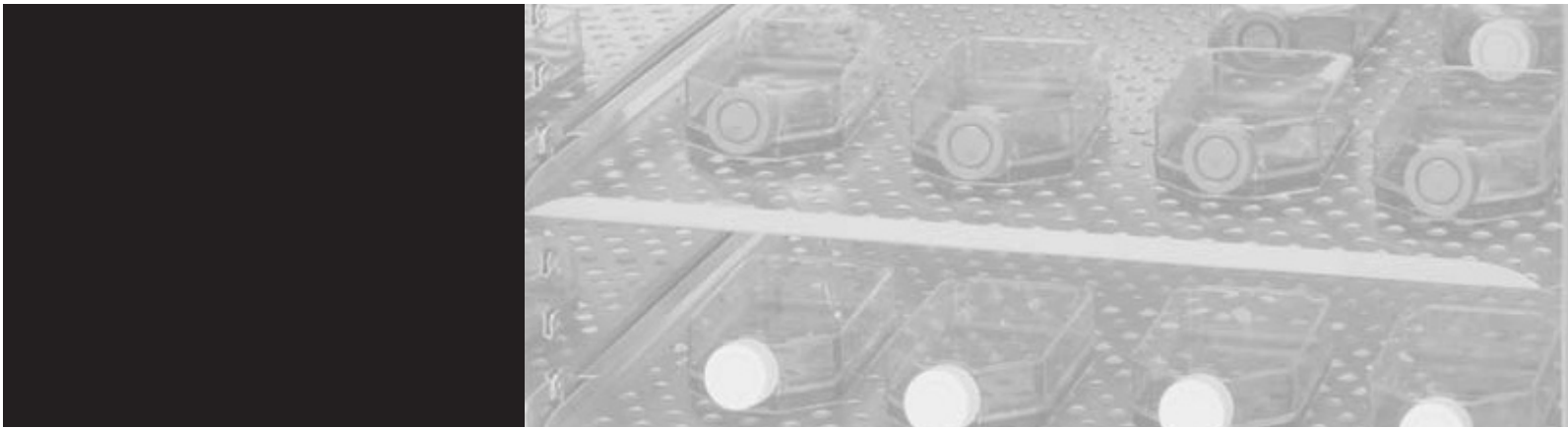

Model	Sensor*	Voltage**	O ₂
3422	IR	115	no
3423	IR	230	no
3424	T/C	115	yes
3425	T/C	230	yes
3426	IR	115	yes
3427	IR	230	yes
3428	T/C	115	no
3429	T/C	230	no

*T/C is a thermal conductivity sensor.

IR is an infra-red sensor.

**All units are 50/60 Hz.

MANUAL NUMBER 7003422

7	25584	8/6/09	Updated RH low alarm ringback time from 30 to 15 minutes	ccs
6	25248/IN-3945	6/9/09	Updated drawer specs - sliding and stationary	ccs
5	25359/IN-3913	3/11/09	Part number of inner heated door from 190630 to 190730 (SRO)	ccs
4	25303/IN-3902	2/17/09	UL decom warning pg 1-7	ccs
3	24975	12/10/08	Updated water specs on pages 1-10 and 1-11	ccs
2	24503	6/9/08	Corrected Chart 2-1 (no span with TC sensor)	ccs
1	24173	6/21/07	Updated with Thermo data	ccs



Important Read this instruction manual. Failure to read, understand and follow the instructions in this manual may result in damage to the unit, injury to operating personnel, and poor equipment performance. ▲

Caution All internal adjustments and maintenance must be performed by qualified service personnel. ▲

Material in this manual is for information purposes only. The contents and the product it describes are subject to change without notice. Thermo Fisher Scientific makes no representations or warranties with respect to this manual. In no event shall Thermo be held liable for any damages, direct or incidental, arising out of or related to the use of this manual.

©2007 Thermo Fisher Scientific. All rights reserved.



Important operating and/or maintenance instructions. Read the accompanying text carefully.



Potential electrical hazards. Only qualified persons should perform procedures associated with this symbol.



Equipment being maintained or serviced must be turned off and locked off to prevent possible injury.



Hot surface(s) present which may cause burns to unprotected skin, or to materials which may be damaged by elevated temperatures.



Marking of electrical and electronic equipment, which applies to electrical and electronic equipment falling under the Directive 2002/96/EC (WEEE) and the equipment that has been put on the market after 13 August 2005.



This product is required to comply with the European Union's Waste Electrical & Electronic Equipment (WEEE) Directive 2002/96/EC. It is marked with the WEEE symbol. Thermo Fisher Scientific has contracted with one or more recycling/disposal companies in each EU Member State European Country, and this product should be disposed of or recycled through them. Further information on Thermo's compliance with this directive, the recyclers in your country and information on Thermo products will be available at www.thermofisher.com.

- ✓ Always use the proper protective equipment (clothing, gloves, goggles, etc.)
- ✓ Always dissipate extreme cold or heat and wear protective clothing.
- ✓ Always follow good hygiene practices.
- ✓ Each individual is responsible for his or her own safety.

Do You Need Information or Assistance on Thermo Scientific Products?

If you do, please contact us 8:00 a.m. to 6:00 p.m. (Eastern Time) at:

1-740-373-4763	Direct
1-800-438-4851	Toll Free, U.S. and Canada
1-740-373-4189	FAX
http://www.thermo.com	Internet Worldwide Web Home Page
service.led.marietta@thermofisher.com	Service E-Mail Address

Our **Sales Support** staff can provide information on pricing and give you quotations. We can take your order and provide delivery information on major equipment items or make arrangements to have your local sales representative contact you. Our products are listed on the Internet and we can be contacted through our Internet home page.

Our **Service Support** staff can supply technical information about proper setup, operation or troubleshooting of your equipment. We can fill your needs for spare or replacement parts or provide you with on-site service. We can also provide you with a quotation on our Extended Warranty for your Thermo Scientific products.

Whatever Thermo Scientific products you need or use, we will be happy to discuss your applications. If you are experiencing technical problems, working together, we will help you locate the problem and, chances are, correct it yourself...over the telephone without a service call.

When more extensive service is necessary, we will assist you with direct factory trained technicians or a qualified service organization for on-the-spot repair. If your service need is covered by the warranty, we will arrange for the unit to be repaired at our expense and to your satisfaction.

Regardless of your needs, our professional telephone technicians are available to assist you Monday through Friday from 8:00 a.m. to 6:00 p.m. Eastern Time. Please contact us by telephone or fax. If you wish to write, our mailing address is:

Thermo Scientific
Controlled Environment Equipment
401 Millcreek Road, Box 649
Marietta, OH 45750

International customers, please contact your local Thermo Scientific distributor.

Warranty Notes

Information You Should Know Before Requesting Warranty Service

- **Locate the model and serial numbers.** A serial tag is located on the unit itself.
- For equipment service or maintenance, or with technical or special application inquiries, contact your local distributor.

Repairs NOT Covered Under Warranty

- **Calibration of control parameters.** Nominal calibrations are performed at the factory; typically $\pm 1^{\circ}\text{C}$ for temperature, $\pm 1\%$ for gases, and $\pm 5\%$ for humidity. Our service personnel can provide precise calibrations as a billable service at your location. Calibration after a warranty repair is covered under the warranty.
- **Damage resulting from use of improper quality water, chemicals or cleaning agents detrimental to equipment materials.**
- **Service calls for improper installation or operating instructions.** Corrections to any of the following are billable services:
 - 1) electrical service connection
 - 2) tubing connections
 - 3) gas regulators
 - 4) gas tanks
 - 5) unit leveling
 - 6) room ventilation
 - 7) adverse ambient temperature fluctuations
 - 8) any repair external to the unit
- **Damage resulting from accident, alteration, misuse, abuse, fire, flood, acts of God, or improper installation.**
- **Repairs to parts or systems resulting from unauthorized unit modifications.**
- **Any labor costs other than that specified during the parts and labor warranty period, which may include additional warranty on CO₂ sensors, blower motors, water jackets, etc.**

Table of Contents

Section 1	Installation and Start-Up	1-1
	Name and Description of Parts	1-1
	Control Panel Keys, Displays & Indicators	1-2
	Control Panel Operation	1-3
	Installing the Unit	1-4
	Incubator Start-Up	1-13
Section 2	Calibration	2-1
	Calibrating the Temperature	2-1
	Calibrating T/C CO ₂ System	2-2
	Calibrating Infra-Red CO ₂ System	2-3
	Calibrating the O ₂ System	2-4
	Calibrating Relative Humidity	2-6
Section 3	Configuration	3-1
	Turning the Audible Alarm ON/OFF	3-1
	New HEPA Filter	3-1
	Setting the REPLACE HEPA Filter Reminder	3-2
	Setting an Access Code	3-2
	Setting Low Temp Alarm Limit	3-3
	Setting High Temp Alarm Limit	3-3
	Enabling Temp Alarms to Trip Contacts	3-4
	Setting Low CO ₂ Alarm Limit	3-4
	Setting High CO ₂ Alarm Limit	3-5
	Enabling CO ₂ Alarms to Trip Contacts	3-5
	Setting New Zero # for T/C CO ₂ Sensors	3-6
	Setting New Span # for T/C CO ₂ Sensors	3-6
	Setting a Low RH Alarm Limit	3-7
	Enabling RH Alarms to Trip Contacts	3-7
	Setting a Low O ₂ Alarm Limit	3-8
	Setting a High O ₂ Alarm Limit	3-8
	Enabling O ₂ Alarms to Trip Contacts	3-9
	Enabling Temp/RH to be Displayed	3-9
	Enabling CO ₂ /O ₂ to be Displayed	3-10

Section 4	Alarms	4-1
	Inner Door Open Alarm	4-2
	Sensor Fault Alarms	4-2
Section 5	Routine Maintenance	5-1
	Cleaning the Interior	5-1
	Cleaning Cabinet Exterior	5-4
	Cleaning Humidity Pan	5-4
	Replacing Fuses	5-4
	HEPA Filter Maintenance	5-6
	Replacing Air Sample Filter	5-6
	Replacing Access Port Filter	5-6
	Draining Water Jacket	5-6
	O ₂ Sensor Fuel Cell	5-7
	Replacing O ₂ Sensor	5-7
	Adding /Replenishing Rust Inhibitor	5-8
	Reversing the Door Swing	5-9
	Preventive Maintenance	5-13
Section 6	Factory Installed Options	6-1
	Humidity Readout	6-1
	Remote Alarm Contacts	6-2
Section 7	Specifications	7-1
	Unit Attachment Location	7-4
	Unit Center of Gravity Locations	7-5
Section 8	Spare Parts	8-1
	Exploded Parts Drawings	8-3
Section 9	Electrical Schematics	9-1
Section 10	Warranty Information	10-1
Section 11	Declaration of Conformity	11-1

Section 1 Installation and Start-Up

Name and Description of Parts

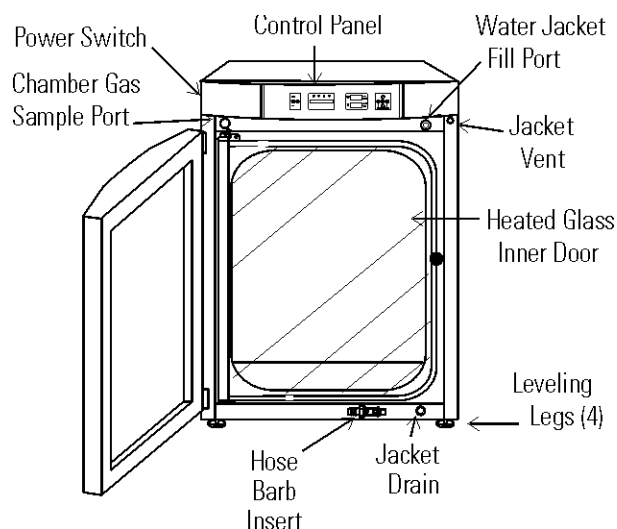



Figure 1-1. Water Jacket Incubator

- Heated Inner Door - Keeps chamber interior dry. Reversible to opposite swing (Section 5).
- Chamber Gas Sample Port - Used for sampling chamber CO₂ content, using a Fyrite or similar instrument. Cap when controlling O₂.
- Main Power Switch
- Control Panel - Keypad, Displays and Indicators (Figure 1-2).
- Fill Port - Used for filling the water jacket.
- Water Jacket Vent- Do not cover! Allows air to escape from the water jacket during filling and normal expansion and contraction when the incubator heats or cools.
- Leveling Legs - Used to level the unit.
- Water Jacket Drain – Use hose barb insert included.

Note The incubators are stackable. Instructions follow in this section. ▲

Control Panel Keys, Displays & Indicators

-  - mutes the audible alarm.
- Visual Alarm Indicator - Pulses on/off during an alarm condition in the unit.
- MODE Select Switch - Used to select Run, Setpoints, Calibration and System Configuration Modes.
- Message Display - Shows system status.
- Mode Select Indicators -
 - RUN: Run Menu
 - SET: Set Points Menu
 - CAL: Calibrate Menu
 - CON: Configuration Menu
- Up/Down Arrows: Increases or decreases number parameter values, toggles choice parameter values.
- ENTER: Accepts changes to calibration settings
- HEAT: Lights when power is applied to heaters.
- T (°C): Shows current chamber temperature in °C.
- RH (%): Shows percentage of humidity currently inside chamber.
- SCROLL FOR PARAMETERS arrows: Moves through choices in selected mode.
- INJ: Lights when gas is injected into the chamber.
- %CO₂: Shows percentage of CO₂ in chamber.
- %O₂: Shows percentage of O₂ in chamber, if applicable.

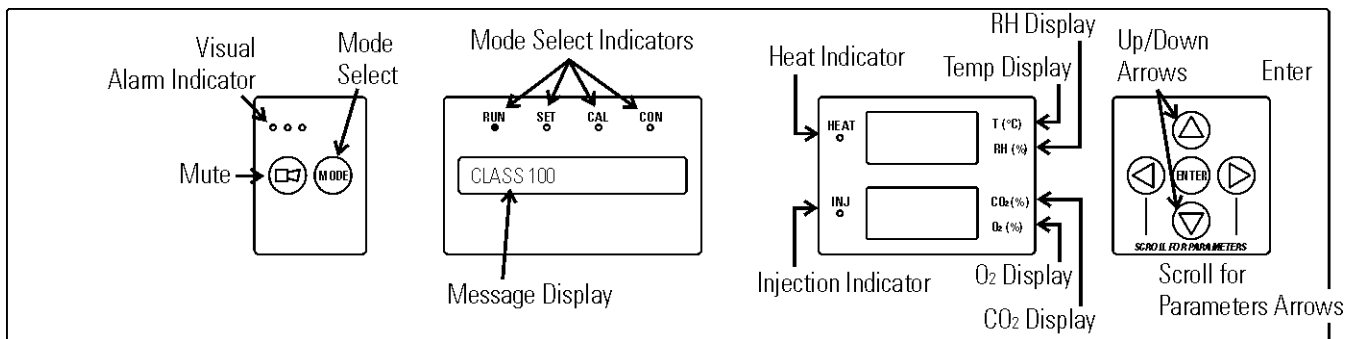

Figure 1-2. Control Panel

Control Panel Operation

The Series 8000WJ incubator has four basic modes to allow incubator setup. The modes are as follows: Run, Setpoints, Calibration and System Configuration.

- RUN is the default mode that the incubator will normally be in during operation.
- SET is used to enter system setpoints for incubator operation.
- CAL is used to calibrate various system parameters to the customer's satisfaction.
- CON is the system configuration mode that allows for custom setup of various options.

SCROLL FOR PARAMETERS: Steps the operator through the parameters of SET, CAL and CON modes. The right arrow goes to the next parameter, the left arrow returns to the previous parameter.

Up Arrow: Increases or toggles the parameter value that has been selected in the SET, CAL, and CON modes.

ENTER: Must press ENTER key to save to memory all changed values.

Down Arrow: Decreases or toggles the parameter values that have been selected in the SET, CAL and CON modes.

 **Key:** Press to mute the audible alarm. See Section 4 for alarm ringback times.

Message Display: Shows system status (Mode) at all times. Shows CLASS 100 or SYSTEM OK during normal operation, or alarm messages if the system detects an alarm condition. See Section 4, Alarms. The message 'CLASS 100' is a timing mechanism indicating that, under normal operating conditions with the HEPA filter installed, the air inside the chamber meets the Class 100 air cleanliness standard for particulates of 0.5 micron size or larger per cubic foot of air. (For further information on the Class 100 classification of air quality, see Appendix A.)

Upper and Lower Displays: The upper display shows Temp and RH, depending on options installed. The lower display shows CO₂ and O₂, depending on options installed.

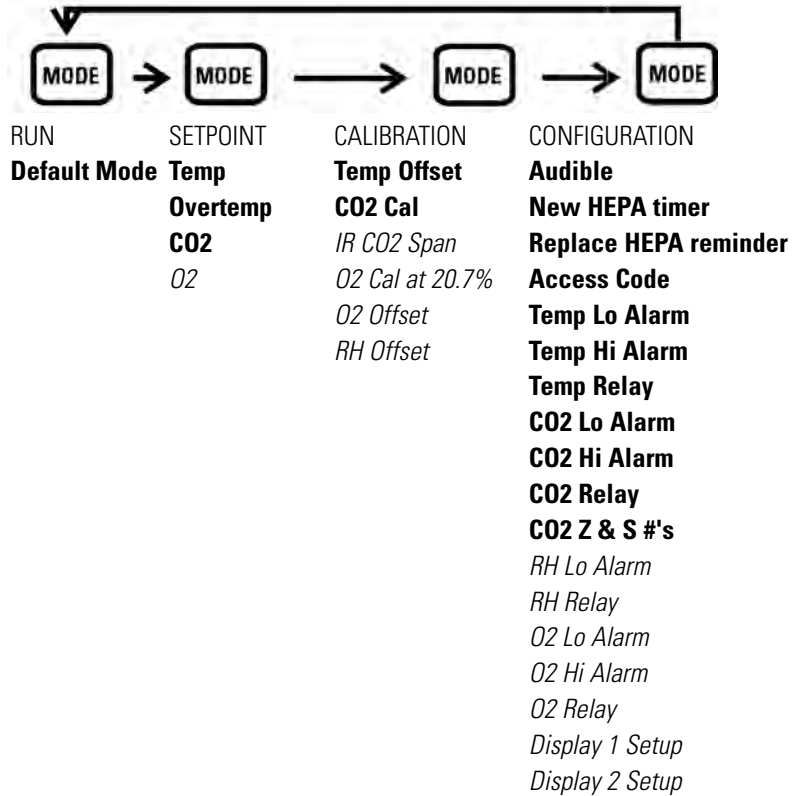

Base Unit Displays

Option Displays

Installing the Unit

1. Locate the unit on a firm, level surface capable of supporting the unit's operational weight of 365 lbs. (166kg).
2. Locate away from doors and windows and heating and air conditioning ducts.
3. Allow enough clearance behind the unit for electrical and gas hook-up.
4. If desired, refer to attachment and center-of-gravity information in Section 7.

Stacking the Incubators

Warning If the units have been in service, disconnect the power cord connector and drain the water jacket of the designated top unit before stacking. ▲

Note Stacking brackets (shown at right) stacking bolts, washers, and bolts for stacking are included with each unit. ▲

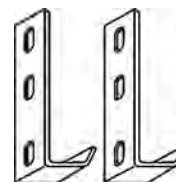

Figure 1-3. Stacking brackets

1. Designate one incubator to be the top unit and the other as the bottom unit. Remove the base cover plate from the top unit using the finger holes in the base or using a slotted screwdriver (Figure 1-4)

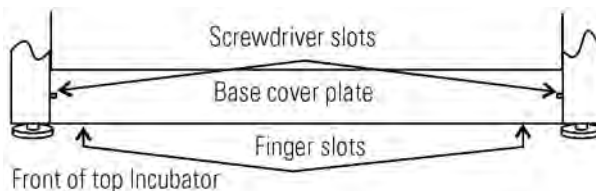

Figure 1-4. Remove Base Cover Plate

2. Note the two slots in the base of the incubator which accommodate the stacking bolts. Refer to Figure 1-5.

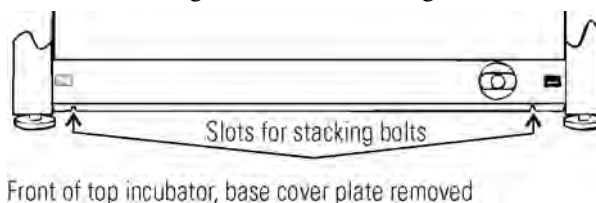

Figure 1-5. Stacking Bolt Slots

3. Remove the two plastic plugs from the bolt holes in the exterior top of the bottom unit. Install the 1/2" long 5/16-18 stacking bolts and washers into the bolt holes - do not tighten the bolts at this time. Refer to Figure 1-6.



Figure 1-6. Bolt Holes

Stacking the Incubators (continued)

4. Unscrew and remove the leveling feet from the top unit and lift it onto the bottom unit, off-setting the base of the top unit approximately 2-3 inches behind the stacking bolts and washers.

Warning This incubator weighs 265 lbs (120kg) before filling. Have sufficient personnel available when lifting. ▲

5. Align the sides of the top unit and bottom unit and slide the top unit forward until the slots in the base of the top unit align with the 5/16"-18 stacking bolts in the exterior top of the bottom unit (Figure 1-7).

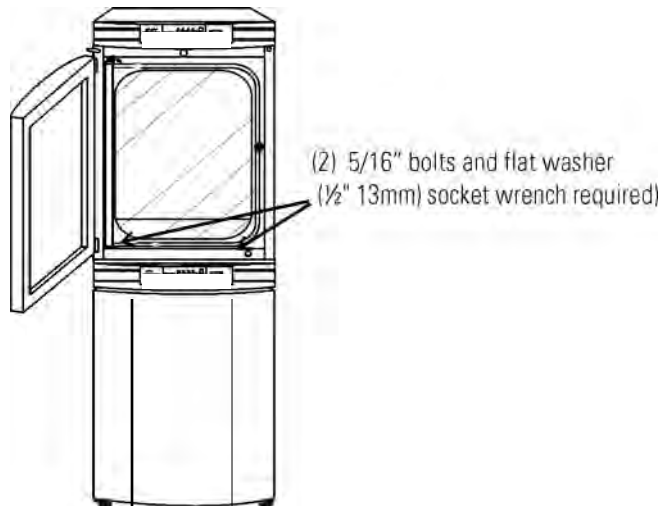

Figure 1-7. Align Slots and Bolts

6. Remove and save the two screws from the back of the control panel on the bottom unit as identified in Figure 1-8.

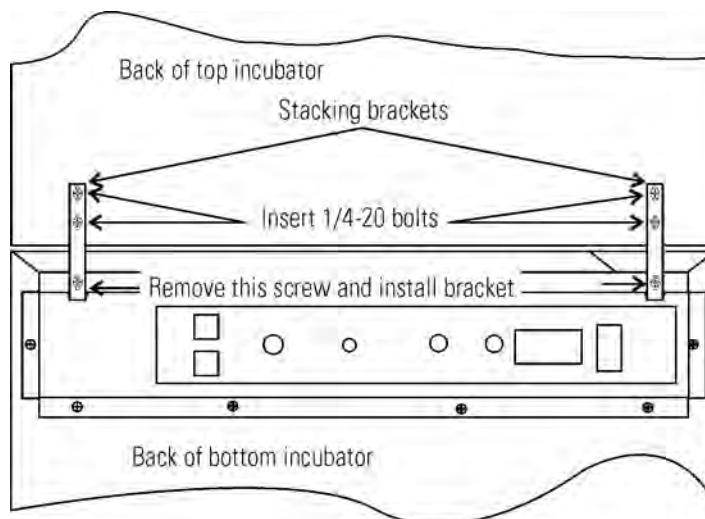

Figure 1-8. Two Screws From Control Panel Back

Stacking the Incubators (continued)

7. Insert the stacking brackets into the slots on the rear of the control panel of the bottom unit as shown in Figure 1-5. Align the slots in the brackets with the mounting holes on the rear of the incubators. Secure the brackets with the screws saved above and the 1/4-20 bolts provided in the stacking kit. A 7/16" (11mm) wrench or socket is required for the bolts.
8. Secure the base of the top unit to the exterior top of the bottom unit by tightening the 5/16-18 stacking bolts using a 1/2" (13mm) wrench or suitable tool.
9. Replace the base cover on the top unit.
10. The stacked units are ready to be placed into service.

Note If desired, refer to center-of-gravity and attachment information in Section 7. ▲

Preliminary Cleaning

1. Remove vinyl from shelf channels, duct sheets, and air duct, if present.
2. Using a suitable laboratory disinfectant, thoroughly clean all interior surfaces including shelves and shelf supports, door gaskets, blower wheel and CO₂ sensor. Refer to Section 5.

Caution Before using any cleaning or decontamination method except those recommended by the manufacturer, users should check with the manufacturer that the proposed method will not damage the equipment. Accidental spills of hazardous materials on or inside this unit are the responsibility of the user. ▲

Installing Access Port Filter

Locate the opening in the top left corner of the interior chamber. Remove the tape from the opening on the outside of the unit. Locate the stopper with filter in the hardware bag. Install in the opening inside the chamber.

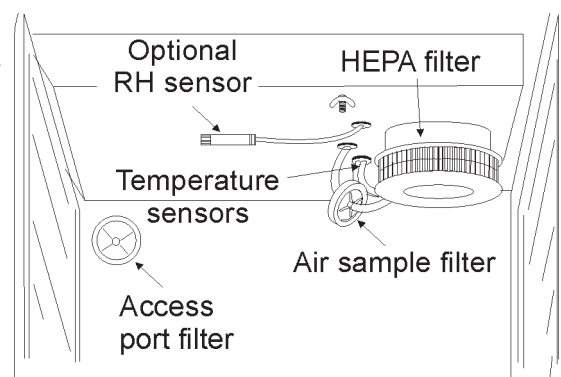

Figure 1-9. Filter and Sensor Locations

Installing Air Sample Filter

1. Remove the filter from the shipping bag.
2. Separate one section of the tubing from the filter. Install this section to the fitting on the blower plate.
3. After installing the top duct, connect the filter assembly to the tubing coming through the top duct.
4. Insert the free end of the air sample filter tubing into the larger hole in the back of the blower scroll. See Figure 1-9 for completed configuration.

Installing HEPA Filter

1. Remove the filter from the shipping box.
2. Remove the plastic coating from the filter, using caution not to touch the filter media.
3. Install the filter as shown in Figure 1-9.
4. To set-up an automatic REPLACE HEPA reminder, see Section 3.

Caution The media of the filter can be damaged if mishandled. To avoid damage to the incubator, do not operate the unit without the HEPA filter in place. ▲

Installing Shelves

1. Install the side ducts with the tabs facing into the center of the chamber with their slots up. There are no right side or left side ducts, simply rotate one of them to fit the opposite side. Tilt the side ducts as they are placed in the chamber so the tops fit into the top air duct, then guide them into the vertical position. Figure 1-10 shows the duct as it would be oriented for the right side of the chamber.
2. Referring to Figure 1-10, note that there is no difference between left and right side shelf channels.

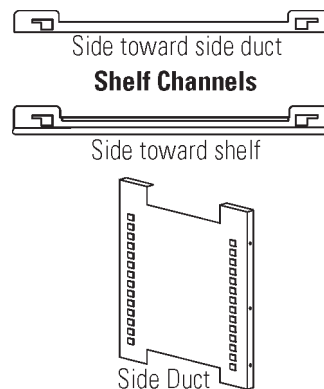

Figure 1-10. Shelf Channels and Side Duct

Installing Shelves (continued)

3. Install the shelf channels by placing the channel's rear slot over the appropriate rear tab on the side duct. Pull the shelf channel forward and engage the channel's front slot into the side duct's appropriate forward tab. Refer to Figure 1-11.

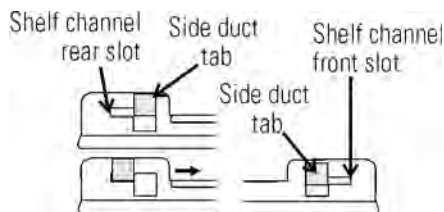

Figure 1-11. Slot and Tab

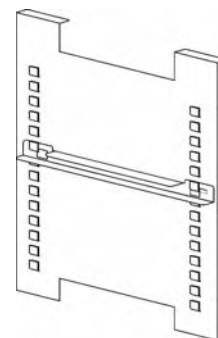

Figure 1-12. Channel Installed

4. Figure 1-12 shows one of the channels installed on the right side duct.

Leveling the Unit

Check the unit for being level by placing a bubble-style level on one of the shelves. Turn the hex nut on the leveler counterclockwise to lengthen the leg, or clockwise to shorten it. Level the unit front-to-back and left-to-right.

Connecting Unit to Electrical Power

See the serial tag on the side of the unit for electrical specifications, or refer to the electrical schematics in Section 9 of this manual.

Warning Connect the incubator to a grounded dedicated circuit only. The power cord connector is the mains disconnect device for the incubator. Position the unit so that it can be easily disconnected. ▲

Plug the provided power cord into the power inlet connector (Figure 1-13) on the back of the unit, and into the grounded dedicated circuit.

Filling Water Jacket

Turn the power switch on. ADD WATER will appear in the message display. Press the Silence key to silence the alarm.

Note that the fill port has a plug that must be removed before filling and replaced after filling is complete.

Caution Chlorine is detrimental to stainless steel. Using chlorinated tap water or additives that contain chlorine will void water-jacket warranty! ▲

Fill the water jacket with 11.7 gallons (43.5 liters) of pure water. Silicone tubing and a funnel are shipped in the accessory bag with the unit.

For ease of connecting/disconnecting, use the silicone tubing provided to connect directly to the fill port. See Figure 1-1 and this detail. Do not install vinyl tubing directly onto the fill port as it may be difficult to remove. A 3/8" to 3/8" hose connector has been provided to attach lengths of vinyl tubing to the silicone fill port tubing, to reach the pure water source.

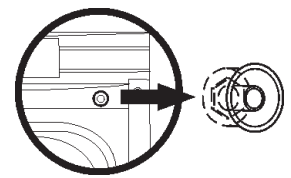

Detail 1

When the jacket is full, the audible alarm will sound a continuous tone for 10 seconds and the alarm condition will be cleared. Refer to Section 4, Table of Alarms.

Note The Series 8000WJ Incubator is shipped from the factory with a rust inhibitor added to the water inside the unit. The rust inhibitor must be replenished every 2 years. See Section 5 to drain the water jacket and for the correct proportion of rust inhibitor to the water. ▲

Filling Humidity Pan

For best operation of the incubator, sterilized distilled, demineralized or de-ionized water should be used in the humidity pan. Water purity should be in the resistance range of 50K to 1M Ohm/cm, or a conductivity range of 20.0 to 1.0 uS/cm. Refer to ASTM Standard D5391-93 or D4195-88 for measuring water purity.

Filling Humidity Pan (continued)

Distillation systems, as well as some types of reverse osmosis water purity systems, can produce water in the quality range specified. Tap water is not recommended as it may contain chlorine, which can deteriorate the stainless steel. Tap water may also have a high mineral content, which would produce a build-up of scale in the pan. High purity or ultra pure water is not recommended as it is an extremely aggressive solvent and will deteriorate the stainless steel. High purity water has a resistance of above 1M to 18M Ohm. Even high purity water can contain bacteria and organic contaminants. Water should always be sterilized or treated with a decontaminant, safe for use with stainless steel as well as safe for the product, prior to being introduced into the humidity pan.

Caution Use of chlorinated water, or decontamination products containing chlorine, will deteriorate the stainless steel and cause rust, voiding the warranty. ▲

Fill the humidity pan to within 1/2 inch of the top with sterile, distilled water. Place the pan directly on the incubator floor to ensure optimum humidity and temperature response.

For applications requiring higher humidity conditions, the pan should be placed against the left side wall of the incubator. The ductwork has been modified for this purpose. Also, on CO₂ control models, the CO₂ sample port may be capped to assist in achieving greater RH. In some ambients, this may cause condensation to form in the chamber.

On CO₂ and O₂ control models, the gas sample port must be capped for proper O₂ control. It is recommended that the humidity pan be placed against the left side wall of the chamber to aid humidity recovery after door openings.

Check the level and change the water frequently to avoid contamination. Do not allow the water level to fluctuate significantly. “Dry-outs” will have an adverse effect on the humidity level as well as CO₂ calibration.

Connecting CO₂ or N₂ (O₂ Option) Gas Supply

Warning High concentrations of CO₂ gas can cause asphyxiation! OSHA Standards specify that employee exposure to carbon dioxide in any eight-hour shift of a 40-hour work week shall not exceed the eight-hour time weighted average of 5000 PPM (0.5% CO₂). The short term exposure limit for 15 minutes or less is 30,000 PPM (3% CO₂). Carbon dioxide monitors are recommended for confined areas where concentrations of carbon dioxide gas can accumulate. ▲

Warning High concentrations of N₂ gas can cause asphyxiation! N₂ and CO₂ can displace oxygen levels in a confined atmosphere. The first signs of hypoxia occur when oxygen levels fall below 17%. They include decreased night vision, increased breathing volume and accelerated heartbeat. Oxygen levels below 6% cause death. Oxygen monitors are recommended for confined areas where concentrations of N₂ or CO₂ may displace oxygen. ▲

The CO₂ gas supply being connected should be industrial grade 99.5% pure and should not contain siphon tubes. The N₂ gas supply being connected should be 99.99% pure. Do not use liquid nitrogen.

Install a two-stage pressure regulator at the cylinder outlet. The high pressure gauge at the tank should have 0-2000 psig range and the low pressure gauge, at the incubator inlet, should have a 0-30 psig range. Input pressure to the incubator must be maintained at 15 psig (103.4 kPa).

The incubator has serrated fittings on the back of the cabinet to connect the gas supply. Refer to Figure 1-13. The fitting is labeled CO₂ Inlet #1 Tank. The N₂ Inlet is also labeled. Make sure that the connections are secured with clamps. Check all fittings for leaks.

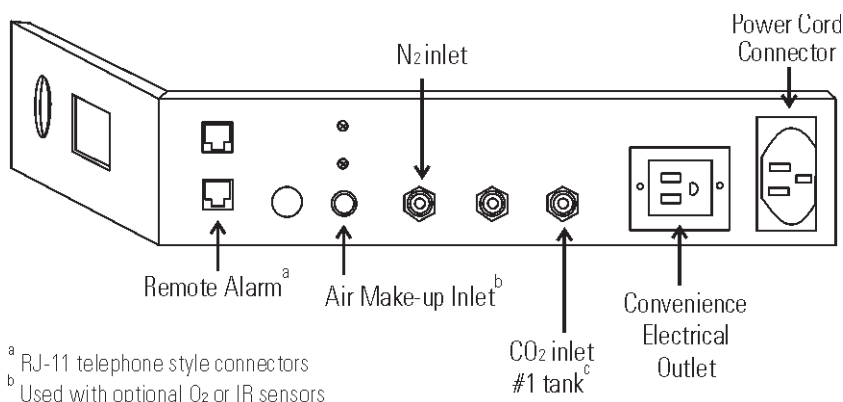

Figure 1-13. Back Panel and All Connections

Connecting CO₂ or N₂ (O₂ Option) Gas Supply (cont.)

Warning This incubator is designed to be operated with CO₂ gas, or N₂ in those units with an O₂ control system. Connecting a flammable or toxic gas can result in a hazardous condition.

Gases other than CO₂ or N₂ should not be connected to this equipment. CO₂ gas cylinders have UN1013 labeled on the cylinder and are equipped with a CGA 320 outlet valve. N₂ compressed gas cylinders have UN1066 labeled on the cylinder and are equipped with a CGA 580 outlet valve. Check the gas cylinder for the proper identification labels.

The CO₂ gas supply being connected to the incubator should be industrial grade, 99.5% pure. Do not use CO₂ gas cylinders equipped with siphon tubes. A siphon tube is used to extract liquid CO₂ from the cylinder, which can damage the pressure regulator. Consult with your gas supplier to ensure that the CO₂ cylinder does not contain a siphon tube. The N₂ gas supply being connected to the incubator should be 99.99% pure. Do not use liquid nitrogen. Gas cylinders should be secured to a wall or other stationary object to prevent tipping.

A two-stage pressure regulator is required to be installed on the outlet valve of the gas cylinder. Input pressure to the incubator must be maintained at 15 psig (103.4kPa) for proper performance of the CO₂ or O₂ control system. (A single stage pressure regulator will not maintain 15 psig (103.4kPa.)

If higher purity CO₂ is desired inside the incubator (greater than 99.5% pure), the pressure regulator should be constructed with a stainless steel diaphragm along with specifying the purity of the CO₂ from the gas supplier. Follow the manufacturer's instructions to ensure proper and safe installation of the pressure regulator on the gas cylinder. Consult your facility safety officer to ensure that the equipment is installed in accordance with the codes and regulations that are applicable in your area. ▲

Incubator Start-Up

Now that the incubator has been properly installed, connected to power, filled with water, humidity pan filled, and connected to gas supplies, system setpoints can be entered. The following setpoints can be entered in SET mode: temperature, over temperature, CO₂, and O₂. To enter SET mode, press the MODE key until the SET indicator lights. Press the right and/or left arrow keys until the proper parameter appears in the message display. See Chart 1-1 for more detail.

Setting the Operating Temperature

Incubator Model 3428 and 3429 have an operating temperature range of 10 to 55°C, Model 3422 and 3423 a range of 10 to 50°C, and Models 3424, 3425, 3426, and 3427 a range of 10 to 45°C. The incubator is shipped from the factory with a temperature setpoint of 10°C. At this setting, all heaters are turned off.

To change the operating temperature setpoint:

1. Press the MODE key until the SET indicator lights.
2. Press the right arrow until Temp XX.X is displayed in the message display.
3. Press the up/down arrow until the desired temperature setpoint is displayed.
4. Press ENTER to save the setpoint.
5. Press the MODE key until the RUN Indicator lights to go to RUN mode, or right/left to go to next/previous parameter.

Setting the Overtemp Setpoint

Caution The independent overtemp circuit is designed as a safety to protect the incubator only. It is not intended to protect or limit the maximum temperature of the cell cultures or customer's equipment inside the incubator if an overtemp condition occurs. ▲

The incubator is equipped with an independent circuit that monitors the air temperature in the cabinet. The independent overtemp circuit is designed as a safety for the incubator only. Should the system's temperature control fail, this circuit would cut out all heaters when the cabinet's temperature reaches the Overtemp setpoint. When an incubator is operating in an overtemp condition, the temperature control in the incubator will be $\pm 1^\circ\text{C}$ around the overtemp setpoint.

The overtemp's function is to prevent abnormally high temperatures that will occur if the heaters are locked on as a result of a failure in the main temperature control. Although the overtemp circuit will control the chamber temperature close to the overtemp setpoint, it is not intended to protect or limit the maximum temperature of the cell cultures or the equipment inside the chamber when the overtemp condition occurs.

Setting the Overtemp Setpoint (continued)

The factory setting for the Overtemp is 40°C. It can be set over a range of temp setpoint +0.5°C to 60°C. If the temperature setpoint is moved above the Overtemp setpoint, the Overtemp will automatically update to 1.0°C + the temp setpoint. It is recommended that the Overtemp setpoint be 1°C over the temp setpoint.

To set the Overtemp setpoint:

1. Press the MODE key until the SET indicator lights.
2. Press the right arrow until Otemp XX.X is displayed in message display.
3. Press the up/down arrow until the desired Overtemp setpoint is displayed.
4. Press ENTER to save the setpoint.
5. Press the MODE key until the RUN Indicator lights to go to RUN mode or right/left to go to next/previous parameter.

Setting CO₂ Setpoint

All T/C CO₂ cells are precalibrated at the factory at 37°C, high humidity, and 10% CO₂. Therefore, if a temperature setpoint of 37°C has been entered, the humidity pan filled, and the CO₂ control is to run between 0-10% with a T/C CO₂ sensor, the CO₂ setpoint may be entered immediately. Otherwise, it is important to allow the unit 12 hours to stabilize at the temperature setpoint before entering the CO₂ setpoint.

All models of the incubator have a CO₂ setpoint range of 0.0% to 20.0%. The incubator is shipped from the factory with a CO₂ setpoint of 0.0%. At this setting, all CO₂ control and alarms are turned off.

To change the CO₂ setpoint:

1. Press the MODE key until the SET indicator lights.
2. Press the right arrow until CO₂ XX.X is displayed in message display.
3. Press the up/down arrow until the desired CO₂ setpoint is displayed.
4. Press ENTER to save the setpoint.
5. Press the MODE key until the RUN Indicator lights to go to RUN mode or right/left to go to next/previous parameter.

Section 1

Installation and Start-Up

Setting O₂ Setpoint

Models 3424/3425 and 3426/3427 have a built-in O₂ control system. The O₂ setpoint range is 1.0% to 21.0%. The incubator is shipped from the factory with a O₂ setpoint of 21.0%. At this setting, all O₂ control and alarms are turned off. The gas sample port must be capped when running controlled O₂ levels.

To change the O₂ setpoint:

1. Press the MODE key until the SET indicator lights.
2. Press the right arrow until O₂ XX.X is displayed in the message display.
3. Press the up/down arrow until the desired O₂ setpoint is displayed.
4. Press ENTER to save the setpoint.
5. Press the MODE key until the RUN Indicator lights to go to RUN mode, or right/left to go to next/previous parameter.

Chart 1-1. Set Mode

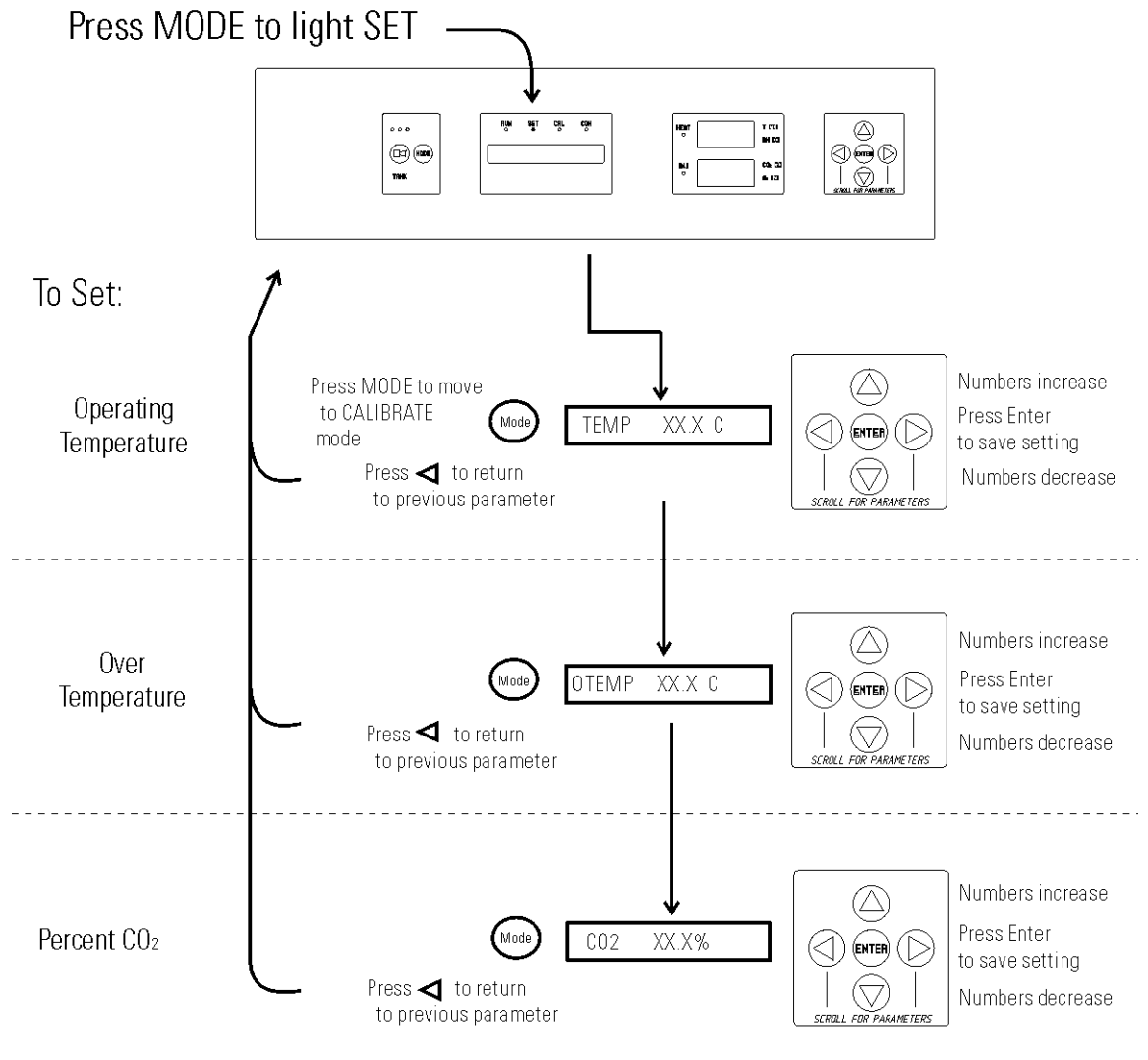

Section 2 Calibration

After the unit has stabilized, several different systems can be calibrated. In the Calibration mode, the air temperature, CO₂ reading, O₂ reading, and RH reading can all be calibrated to reference instruments. To enter Calibration mode, press the MODE key until the CAL indicator lights. Press the right and/or left arrow until the proper parameter appears in the message display. See Chart 2-1 for more detail.

Calibration frequency is dependent on use, ambient conditions, and accuracy required. Good laboratory practice would require at least an annual calibration check. On new installations, all parameters should be checked after the stabilization period. Some T/C CO₂ sensors go through an aging period, especially on new installations. Calibration should be checked on a weekly basis, and adjusted as necessary. When stabilization occurs, checks can become less frequent. When using O₂ controls, all parameters should be checked before each test experiment, or at least every 6 months.

Prior to calibration, the user should be aware of the following system functions. While the unit is in Calibration mode, all system control functions will be stopped so that the unit remains stable. Readout of the system being calibrated will appear as “—” on the readout displays. If no keys are pressed for approximately five minutes while in Calibration mode, the system will reset to RUN mode so that control functions can be reactivated.

Before making an calibration or adjustments to the unit, it is imperative that all reference instruments be properly calibrated.

Calibrating the Temperature

Place the calibrated instrument in the center of the chamber. The instrument should be in the airflow, not against the shelf. Before calibration, allow the cabinet temperature to stabilize.

Temperature Stabilization Periods

Start-Up - Allow 12 hours for the temperature in the cabinet to stabilize before proceeding.

Operating Unit - Allow at least two hours after the display reaches setpoint for the temperature to stabilize before proceeding.

1. Press the MODE key until the CAL indicator lights.
2. Press the right arrow until TEMPCAL XX.X appears in the message display.
3. Press the up/down arrow to match the display to a calibrated instrument.
4. Press ENTER to store the calibration into memory.
5. Press the MODE key to return to RUN mode, or the right/left arrow to go to the next/previous parameter.

Calibrating T/C CO₂ System

Models 3424, 3425, 3428, and 3429 have a thermal conductivity (T/C) CO₂ sensor. Thermal conductivity of the incubator atmosphere is not only effected by the quantity of CO₂ present, but also by the air temperature and the water vapor present in the incubator atmosphere. In monitoring the effects of CO₂, air temperature and absolute humidity must be held constant so any change in thermal conductivity is caused only by a change in CO₂ concentration.

Changing temperature or changing from elevated humidity levels to room ambient humidity levels would necessitate a recalibration of the CO₂ control.

Some T/C CO₂ sensors go through an aging period, especially on new installations. Calibration should be checked on a weekly basis, and adjusted as necessary. When stabilization occurs, checks can become less frequent.

T/C CO₂ Sensor Stabilization Periods

Start-up - The CO₂ sensor has been calibrated at the factory for 37°. Allow temperature, humidity, and CO₂ levels in the chamber to stabilize at least 12 hours before checking the CO₂ concentration with an independent instrument.

Presently operating - Make sure the chamber doors are closed. Allow at least 2 hours after the temperature and CO₂ displays reach their set-points for chamber atmosphere stabilization.

1. Make sure stabilization periods outlined above are followed.
2. Sample the chamber atmosphere through the sample port with an independent instrument. Sample the atmosphere at least 3 times to ensure the accuracy of the instrument.
3. Press the MODE key until the CAL indicator lights.
4. Press the right arrow until CO₂ CAL XX.X is displayed in the message display.
5. Press the up/down arrow to change the display to match the independent instrument.
6. Press ENTER to store calibration.
7. Press the MODE key to return to RUN mode, or the right or left arrow keys to go to the next/previous parameter.

Calibrating Infra-Red CO₂ System

Models 3422, 3423, 3426, and 3427 have an infra-red CO₂ sensor. Infra-red CO₂ sensors are not effected by chamber atmosphere temperature or humidity. However, the light detector in the sensor is effected by wide temperature changes. Therefore, changing temperature setpoints could necessitate a recalibration of the CO₂. Chamber temperature should be allowed to stabilize before checking CO₂ concentrations with an independent instrument, especially on start-up.

All models equipped with an IR/CO₂ sensor have an automatic calibration that occurs every 24 hours, and lasts for 5 to 6 minutes. During automatic calibration, the CO₂ display is blanked out and HEPA filtered room air is pumped through the CO₂ sensor. A new CO₂ calibration value is stored in memory for use as the 0.0% CO₂ reference point. The keypad/ control panel is locked during calibration, with the message display reading CO₂ AUTO CAL.

IR CO₂ Sensor Stabilization Times

Startup - Allow the temperature and the CO₂ of the cabinet to stabilize at least 12 hours before proceeding.

Operating Unit - Allow CO₂ to stabilize at least 2 hours at setpoint before proceeding.

To ensure accurate calibration, the unit will not allow CO₂ to be spanned below 3%. If the cabinet does not contain at least 3% CO₂, increase the setpoint and allow the unit to stabilize before completing this procedure.

1. Measure the CO₂ concentration in the chamber through the gas sample port with a Fyrite or other independent instrument. Several readings should be taken to ensure accuracy.
2. Press the MODE key until the CAL indicator lights.
3. Press the right arrow until IR CAL XX.X appears in the message display.
4. Press the up/down arrow to adjust the display to match the independent instrument reading.
5. Press ENTER to store calibration.
6. After ENTER is pressed, the unit will go into a calibration cycle that lasts 5 to 6 minutes. Control panel is locked during this calibration cycle.
7. Press the MODE key to return to RUN mode.

Calibrating the O₂ System

Models 3424, 3425, 3426 and 3427 have an O₂ control sensor. The sensor is a fuel cell that puts out a linear millivolt signal based on O₂ content of the chamber. The fuel cell depletes over time depending on required O₂ levels, therefore the system should be calibrated before each test experiment, or at least every 6 months.

There are two methods available to calibrate the O₂ system.

- The preferred method calibrates the system to the known ambient O₂ value of 20.7% and checks the life of the sensor. This method should be used whenever a new sensor is installed.
- The second method available allows the system to be calibrated to an independent reference instrument by entering an offset.

O₂ Calibration at 20.7%

1. Press the MODE key until the CAL indicator lights.
2. Press the right arrow until the display reads O₂ CAL@20.7%.
3. Press ENTER.
4. OPEN DOOR appears on the display. Open the outer and inner doors.
5. The display reads CALIBRATING.
6. When calibration is complete, approximately 2 minutes, an audible tone sounds and the display returns to O₂ CAL@20.7%.
7. The O₂ display will change to 20.7.
8. Press the MODE key to return to RUN mode.

A new O₂ span value is stored in memory for use as the 20.7% O₂ reference point. The keypad/control panel is "locked-up" during calibration.

Caution If using an O₂ Fyrite, the accuracy of the instrument will be greatly affected by the concentration of CO₂ in the cabinet. Refer to the Fyrite operating manual. ▲

O₂ Offset Calibration

Startup - Allow the cabinet to stabilize at least 12 hours before proceeding.
Operating Unit - Allow O₂ to stabilize at least 2 hours at set point before proceeding.

Measure the O₂ concentration in the chamber through the gas sample port with an independent instrument. Take several readings to ensure accuracy.

1. Press the MODE key until the CAL indicator lights.
2. Press the right arrow until O₂ OFFS XX.X appears in message display.
3. Press the up/down arrow to adjust display to independent instrument reading.
4. Press ENTER to store calibration.
5. Press the MODE key to return to RUN mode.

Calibrating Relative Humidity

All Series 8000WJ incubators can be equipped with an optional direct readout relative humidity sensor. This is a readout only of the chamber relative humidity. It does not provide any control of the relative humidity in the cabinet.

Relative Humidity Stabilization Times

Startup - Allow 12 hours for the relative humidity and temperature in the chamber to stabilize before proceeding.

Operating Unit - Allow at least 2 hours after temperature display reaches setpoint for relative humidity to stabilize before proceeding.

1. Place an accurate independent instrument in the center of the chamber. Allow at least 30 minutes for RH to stabilize.
2. Press the MODE key until the CAL indicator lights.
3. Press the right arrow key until RH CAL XX appears in message display.
4. Press the up/down arrow to match the display to the independent instrument.
5. Press ENTER to store the calibration.
6. Press the MODE key to return to RUN mode.

If a reliable RH measuring device is not available, the display may be calibrated to a typical level.

1. Follow the RH stabilization periods outlined above.
2. With a full humidity pan and stable temperature, the relative humidity in the chamber will be 95%.
3. Using Steps 3-5 of the relative humidity sensor adjustment above, adjust the display to 95%.
4. This calibration method should be accurate to within 5%.

Chart 2-1

Calibrate Mode

Press MODE to light CAL

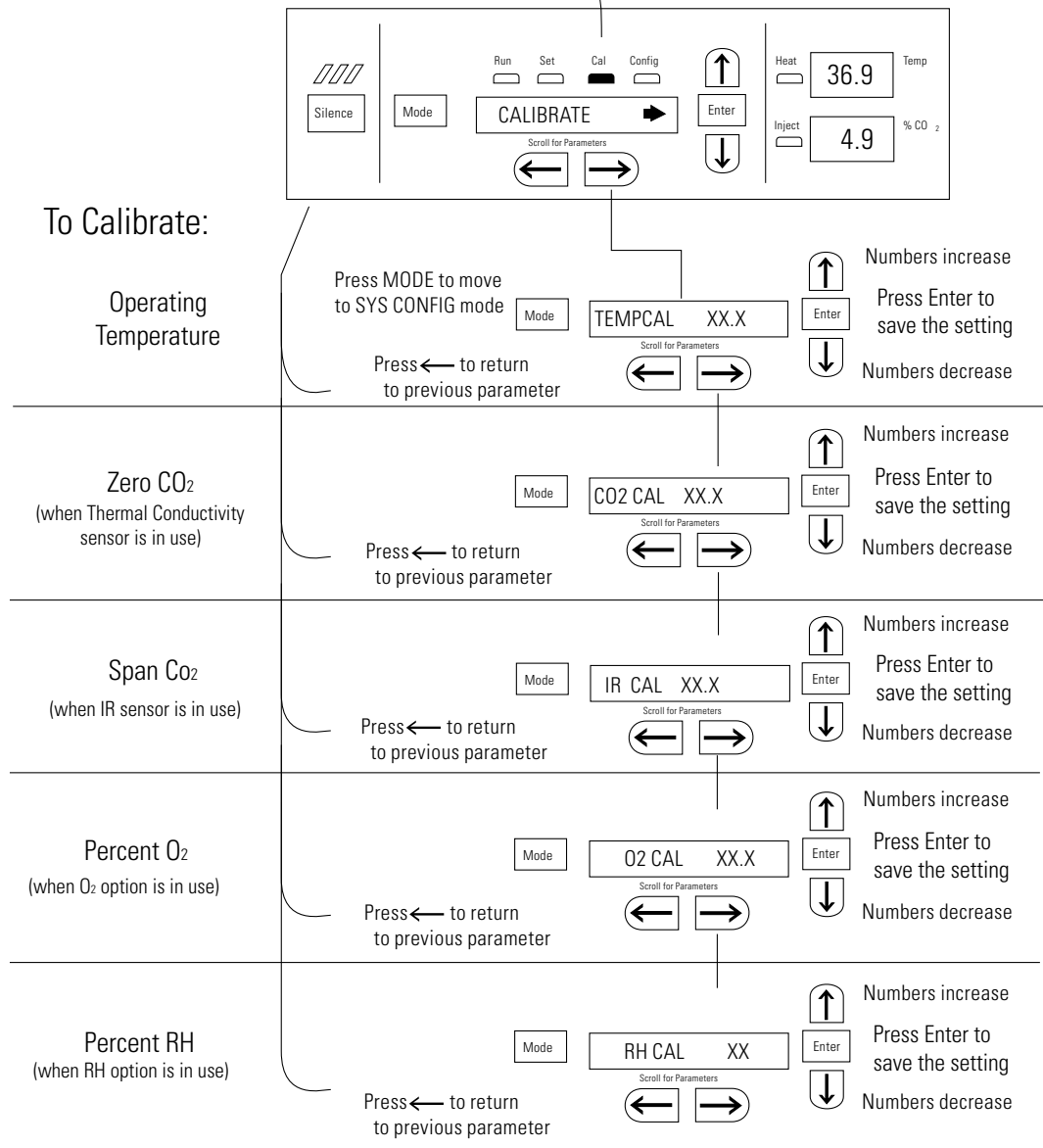

Section 3 Configuration

There are many features available in Configuration mode that allow custom setup of the incubator. These features are listed and described below. All features may not be necessary in all applications, but are available if needed. To enter Configuration mode, press the MODE key until the CON indicator lights. Press the right or left arrow until the appropriate parameter appears in the message display. See Chart 3-1 for more detail.

Turning the Audible Alarm ON/OFF

The audible alarm can be turned on or off. The factory setting is ON.

1. Press the MODE key until the CON indicator lights.
2. Press the right arrow until Audible XXX is displayed in message display.
3. Press the up/down arrow to toggle Audible ON/OFF.
4. Press ENTER to save the setting.
5. Press the MODE key to return to RUN mode or right/left to go to next/previous parameter.

New HEPA Filter

When the REPLACE HEPA reminder is displayed and the visual alarm flashes, the specified time has elapsed and the HEPA filter should be replaced. To clear the display and reset the timer after replacing the HEPA filter with a new one, follow the steps below.

1. Press the MODE key until the CON indicator lights.
2. Press the right arrow until NEW HEPA is displayed in message display.
3. Press ENTER to restart the timer and clear the REPLACE HEPA alarm.
4. Press the MODE key to return to RUN mode.

Setting the REPLACE HEPA Filter Reminder

A HEPA filter replacement timer can be set for a specific amount of time, from 1 to 12 months of actual unit running time. Time will not accrue when the unit is turned off. The default time is 6 months. When the allotted time has run out, REPLACE HEPA appears in the display and the visual alarm flashes. To set the reminder, use the following procedure.

1. Press the MODE key until the CON indicator lights.
2. Press the right arrow until REPL HEPA XX is displayed.
3. Press the up/down arrow to choose the number of months desired.
4. Press ENTER to save the number.
5. Press the MODE key to return to RUN mode or right/left to go to next/previous parameter.

Note After the reminder has been set, check the allotted time remaining by going to Configuration mode, then pressing the right arrow until NEW HEPA XXX displays. This number is the remaining days before the filter replacement time specified runs out. For example, if 12 months was chosen in the REPL HEPA XX message screen, the NEW HEPA number would be 365 days. ▲

Setting an Access Code

A three-digit Access Code can be entered to avoid unauthorized personnel from changing the setpoints, calibration, or configuration. A setting of 000 will bypass the access code. The factory setting is 000.

1. Press the MODE key until the CON indicator lights.
2. Press the right arrow until Acc Code XXX is displayed in the message display.
3. Press the up/down arrow to change the access code.
4. Press ENTER to save the access code.
5. Press the MODE key to return to RUN mode or right/left to go to next/previous parameter.

Setting Low Temp Alarm Limit

The low temp alarm limit (tracking alarm) is the deviation from the temperature setpoint, which will cause a low temp alarm. The low temp alarm is variable from 0.5° below setpoint to 5.0° below setpoint. The factory setting is 1.0° below setpoint. A minus sign (-) in the display indicates that the alarm setting is below the setpoint.

1. Press the MODE key until the CON indicator lights.
2. Press the right arrow until Temp LO -X.X is displayed in the message display.
3. Press the up/down arrow to change the low temp alarm limit.
4. Press ENTER to save the low temp alarm limit.
5. Press the MODE key to return to RUN mode or right/left to go to next/previous parameter.

Setting High Temp Alarm Limit

The high temp alarm limit (tracking alarm) is the deviation from the temperature setpoint that will cause a high temp alarm. It should be noted that this varies from the Overtemp setpoint, in that the Overtemp setpoint configures an independent system that monitors temperature and shuts down the system heaters if necessary. The high temp alarm limit is simply set to enable an audible and visual alarm that notifies the user of a problem. The high temp alarm is variable from 0.5° above setpoint to 5.0° above setpoint. The factory setting is 1.0° above setpoint.

1. Press the MODE key until the CON indicator lights.
2. Press the right arrow until Temp Hi X.X is displayed in the message display.
3. Press the up/down arrow to change the high temp alarm limit.
4. Press ENTER to save the high temp alarm limit.
5. Press the MODE key to return to RUN mode or right/left to go to next/previous parameter.

Enabling Temp Alarms to Trip Contacts

High and Low temperature alarms can be programmed to trip the remote alarm contacts. A setting of ON will cause this, a setting of OFF will not allow temp alarms to trip the contacts. The factory setting is ON.

1. Press the MODE key until the CON indicator lights.
2. Press the right arrow until Tmp Rly XXX is displayed in the message display.
3. Press the up/down arrow to toggle the setting ON/OFF.
4. Press ENTER to save the setting
5. Press the MODE key to return to RUN mode or right/left to go to next/previous parameter.

Setting Low CO₂ Alarm Limit

The low CO₂ alarm limit (tracking alarm) is the deviation from the CO₂ setpoint that will cause a low CO₂ alarm. The setpoint is variable from 0.5% CO₂ below setpoint to 5.0% CO₂ below setpoint. The factory setting is 1.0% CO₂ below setpoint. A minus (-) in the display indicates that the alarm setting is below the setpoint.

1. Press the Mode Key until the CON indicator lights.
2. Press the right arrow until CO₂ LO -X.X is displayed in the message display.
3. Press the up/down arrow to change the low CO₂ alarm limit.
4. Press ENTER to save the low CO₂ alarm limit.
5. Press the MODE key to return to RUN mode or right/left to go to next/previous parameter.

Setting High CO₂ Alarm Limit

The high CO₂ alarm limit (tracking alarm) is the deviation from the CO₂ setpoint that will cause a high CO₂ alarm. The setpoint is variable from 0.5% CO₂ above setpoint to 5.0% CO₂ above setpoint. The factory setting is 1.0% CO₂ above setpoint.

1. Press the MODE key until the CON indicator lights.
2. Press the right arrow until CO2 Hi X.X is displayed in the message display.
3. Press the up/down arrow to change the high CO₂ alarm limit.
4. Press ENTER to save the high CO₂ alarm limit.
5. Press the MODE key to return to RUN mode or right/left to go to next/previous parameter.

Enabling CO₂ Alarms to Trip Contacts

High and Low CO₂ alarms can be programmed to trip the remote alarm contacts. A setting of ON will cause this; a setting of OFF will not allow CO₂ alarms to trip the contacts. The factory setting is ON.

1. Press the MODE key until the CON indicator lights.
2. Press the right arrow until CO2 Rly XXX is displayed in the message display.
3. Press the up/down arrow to toggle the setting ON/OFF.
4. Press ENTER to save the setting.
5. Press the MODE key to return to RUN mode or right/left to go to next/previous parameter.

Setting New Zero # for T/C CO₂ Sensors

If a new T/C CO₂ sensor is being installed, the two numbers on the factory installed sticker on the T/C cell must be entered to calibrate the CO₂ in the unit.

Note For the technician's convenience, a label containing the two numbers on the T/C cell is affixed inside the electronics drawer. ▲

1. Press the MODE key until the CON indicator lights.
2. Press the right arrow until T/CZ# XXXX is displayed in the message display.
3. Press the up/down arrow to change the zero number to match the sticker.
4. Press ENTER to save the setting.
5. Press the MODE key to return to RUN mode or right/left to go to next/previous parameter.

Setting New Span # for T/C CO₂ Sensors

If a new T/C CO₂ sensor is being installed, the two numbers on the factory installed sticker on the T/C cell must be entered to calibrate the CO₂ in the unit.

Note For the technician's convenience, a label containing the two numbers on the T/C cell is affixed inside the electronics drawer. ▲

1. Press the MODE key until the CON indicator lights.
2. Press the right arrow until T/CS# XXXX is displayed in the message display.
3. Press the up/down arrow to change the span number to match the sticker.
4. Press ENTER to save the setting.
5. Press the MODE key to return to RUN mode or right/left to go to next/previous parameter.

Setting a Low RH Alarm Limit

On units that have the RH option installed, a low RH alarm limit may be entered. The low RH alarm limit is the %RH in the cabinet that will cause a low RH alarm. The setpoint is variable from setpoint 0 to 90 %RH. The factory setting is 0% RH, which disables the alarm.

1. Press the MODE key until the CON indicator lights.
2. Press the right arrow until RH Lo XX is displayed in the message display.
3. Press the up/down arrow to change the RH low alarm limit.
4. Press ENTER to save the RH low alarm limit.
5. Press the MODE key to return to RUN mode or right/left to go to next/previous parameter.

Enabling RH Alarms to Trip Contacts

The low RH alarm can be programmed to trip the remote alarm contacts. A setting of ON will cause this, a setting of OFF will not allow the RH alarm to trip the contacts. The factory setting is ON.

1. Press the MODE key until the CON indicator lights.
2. Press the right arrow until RH Rly XXX is displayed in the message display.
3. Press the up/down arrow to toggle the setting ON/OFF.
4. Press ENTER to save the setting.
5. Press the MODE key to return to RUN mode or right/left to go to next/previous parameter.

Setting a Low O₂ Alarm Limit

On models with a O₂ control system, O₂ alarms may be configured. The low O₂ alarm limit (tracking alarm) is the deviation from the O₂ setpoint that will cause a low O₂ alarm. The setpoint is variable from 0.5% O₂ below setpoint to 5.0% O₂ below setpoint. The factory setting is 1.0% O₂ below setpoint. A minus (-) in the display indicates that the alarm setting is below setpoint.

1. Press the MODE key until the CON indicator lights.
2. Press the right arrow until O₂ LO -X.X is displayed in message display.
3. Press the up/down arrow to change the low O₂ alarm limit.
4. Press ENTER to save the low O₂ alarm limit.
5. Press the MODE key to return to RUN mode or right/left to go to next/previous parameter.

Setting a High O₂ Alarm Limit

On models with a O₂ control system, O₂ alarms may be configured. The high O₂ alarm limit (tracking alarm) is the deviation from O₂ setpoint that causes a high O₂ alarm. The setpoint is variable from 0.5% O₂ above setpoint to 5.0% O₂ above setpoint. The factory setting is 1.0% O₂ above setpoint.

1. Press the MODE key until the CON indicator lights.
2. Press the right arrow until O₂ Hi X.X is displayed in message display.
3. Press the up/down arrow to change the high O₂ alarm limit.
4. Press ENTER to save the high O₂ alarm limit.
5. Press the MODE key to return to RUN mode or right/left to go to next/previous parameter.

Enabling O₂ Alarms to Trip Contacts

On models with an O₂ control system, O₂ alarm contacts may be configured to trip the contacts. A setting of ON causes this, a setting of OFF does not allow O₂ alarms to trip contacts. The factory setting is ON.

1. Press the MODE key until the CON indicator lights.
2. Press the right arrow until O₂ Rly XXX is displayed in message display.
3. Press the up/down arrow to toggle the setting ON/OFF.
4. Press ENTER to save the setting.
5. Press the MODE key to return to RUN mode or right/left to go to next/previous parameter.

Enabling Temp/RH to be Displayed

On units that are equipped with the RH option, the upper seven-segment display on the control panel can be configured to display Temp continuously, RH continuously, or toggle between Temp and RH. If the units does not have RH, the upper display will always display temperature. If temperature is set to ON and the RH is set OFF, temperature will be displayed continuously. If temperature is set to OFF and RH is set to ON, RH will be displayed continuously. If both are turned ON, the display will toggle between the two. The factory setting will default to toggle mode if the RH option is present.

1. Press the MODE key until the CON indicator lights.
2. Press the right arrow until Disp Tmp XXX or Disp RH XXX is displayed in the message display.
3. Press the up/down arrow to toggle the setting ON/OFF.
4. Press ENTER to save the setting.
5. Press the MODE key to return to RUN mode or right/left to go to next/previous parameter.

Enabling CO₂/O₂ to be Displayed

On models that are equipped with the O₂ system, the lower seven-segment display on the control panel can be configured to display CO₂ continuously, O₂ continuously, or toggle between CO₂ and O₂. If the units does not have O₂, the lower display will always display CO₂. If CO₂ is set to ON and the O₂ is set OFF, CO₂ will be displayed continuously. If CO₂ is set to OFF and O₂ is set to ON, O₂ will be displayed continuously. If both are turned ON, the display will toggle between the two. The factory setting will default to toggle mode if the O₂ system is present.

1. Press the MODE key until the CON indicator lights.
2. Press the right arrow until Disp CO₂ XXX or Disp O₂ XXX is displayed in the message display.
3. Press the up/down arrow to toggle the setpoint.
4. Press ENTER to save the setpoint.
5. Press the MODE key to return to RUN mode or right/left to go to next/previous parameter.

Chart 3-1. Configuration Mode Page 1 of 3

Press MODE to light CON:

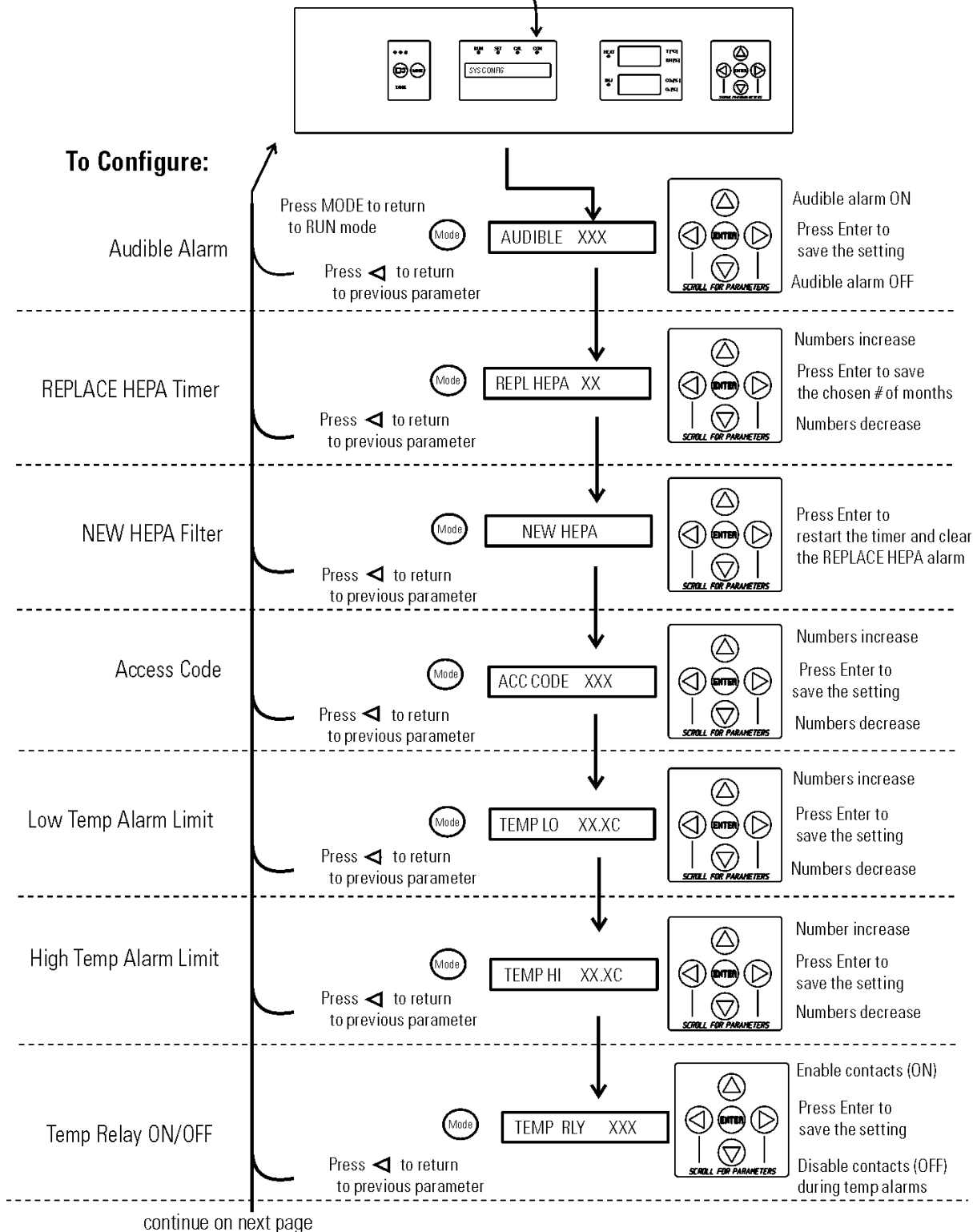

Chart 3-1. Configuration Mode Page 2 of 3

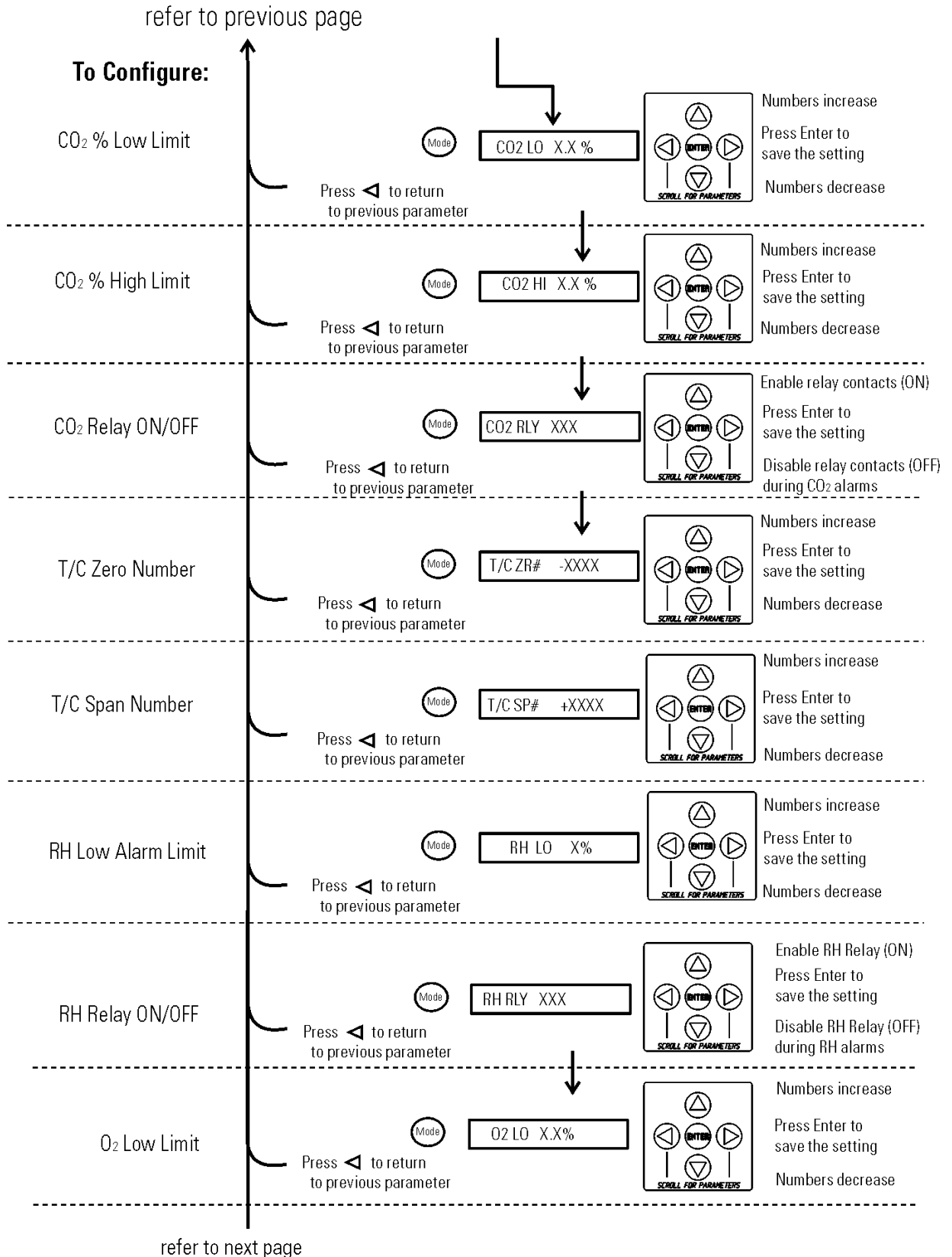
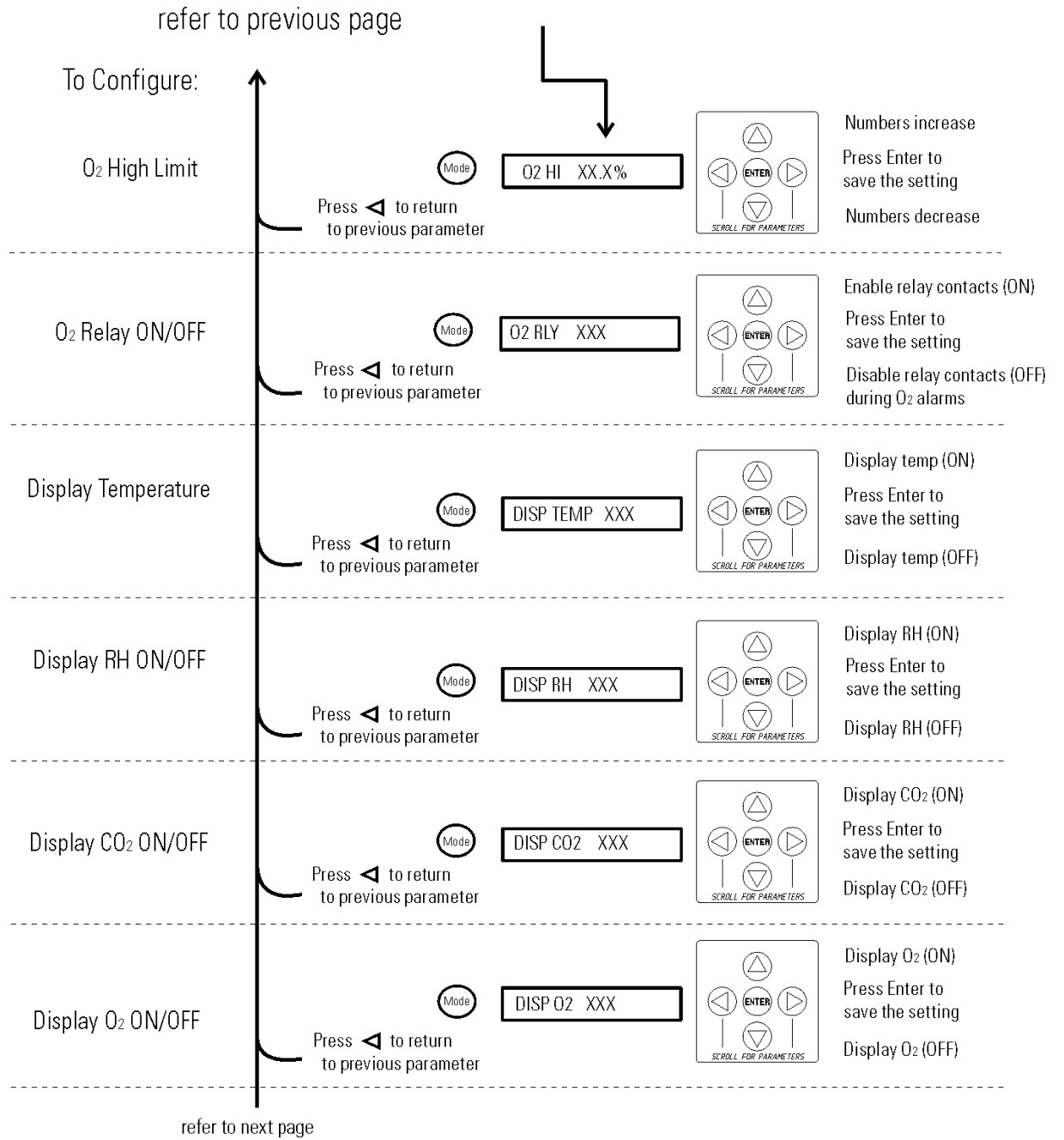

Chart 3-1. Configuration Page 3 of 3



Section 4 Alarms

The Series 8000WJ incubator alarm system is shown in the table below. When an alarm is active, the message appears in the LED message display. Pressing Silence disables the audible alarm for the ringback period. However, the visual alarm continues until the incubator returns to a normal condition. The alarms are momentary alarms only. When an alarm condition occurs and then returns to normal, the incubator automatically clears the alarm condition and the display.

Table 4-1. Alarms

Description	Message	Delay	Ringback	Relay
No alarm condition exists	SYSTEM OK/CLASS 100	----	----	----
CO2 System Auto Calibrating	CO2 AUTO CAL	----	----	----
Temp > Otemp Setpoint	SYS IN OTEMP	0 min.	15 min.	Yes
Temp Control Sensor Fault (See Sect 4)	TSNSR1 ERR	0 min.	15 min.	No
Over Temp Sensor Fault (See Sect 4)	TSNSR2 ERR	0 min.	15 min.	No
CO2 Sensor Fault (See Sect 4)	CO2 SNSR ERR	0 min.	15 min.	No
O2 Sensor Fault (O2 option, see Sect 4)	O2 SNSR ERR	0 min.	15 min.	No
O2 Sensor Low (O2 option, see Sect 4)	REPL O2 SNSR	0 min.	----	No
CO2 Sensor cannot be calibrated (IR option, Sect. 4)	REPL IR SNSR	0 min.	15 min.	No
Replace HEPA filter reminder – set time expired (See Sect. 3)	REPLACE HEPA	0 min.	----	No
Water low in jacket	ADD WATER	0 min.	15 min.	No
Inner Door is Open	DOOR OPEN	15 min.	15 min.	No
CO2 > CO2 High Tracking Alarm	CO2 IS HIGH	15 min.	15 min.	Programmable
CO2 < CO2 Low Tracking Alarm	CO2 IS LOW	15 min.	15 min.	↓
TEMP > TEMP High Tracking Alarm	TEMP IS HIGH	0 min.	15 min.	Programmable
TEMP < TEMP Low Tracking Alarm	TEMP IS LOW	15 min.	15 min.	↓
O2 > O2 High Tracking Alarm (O2 option)	O2 IS HIGH	15 min.	15 min.	Programmable
O2 < O2 Low Tracking Alarm (O2 option)	O2 IS LOW	15 min.	15 min.	↓
RH < RH Low Limit Alarm (RH option)	RH IS LOW	30 min.	15 min.	Programmable
CO2 Auto-Zero Fault (IR option, see Sect. 4)	IR AUTOZ ERR	0 min.	15 min.	No

- All alarm delays and ringback times are +/- 30 seconds -

When multiple alarm conditions occur, active messages are displayed in the message display one at a time, updating at 5 second intervals. Pressing Silence during multiple alarms causes all active alarms to be silenced and to ring back in 15 minutes.

The temperature alarms are disabled when the Temp setpoint is 10°C. The CO₂ alarms are disabled when the CO₂ setpoint is 0.0%. The O₂ alarms are disabled when the O₂ setpoint is 21.0%.

Inner Door Open Alarm

When the inner door is opened on a Series 8000WJ incubator, heat and CO₂ injection are disabled. The door must be securely latched for heat and CO₂ injection to resume after a door opening. If the door is latched, yet the display still shows Door Open, the door switch could be faulty. Call Technical Services.

Sensor Fault Alarms

The microprocessor in the incubator continually scans all available sensors, except the O₂ (see Section 4), to ensure proper operation. Should an error be detected, the incubator sounds an alarm and displays the appropriate message. If such an alarm occurs, contact your local distributor or the Technical Services department at 740-373-4763 or 1-800-438-4851 (USA and Canada) or fax 740-373-4189.

REPL O2 SNSR

On units equipped with the O₂ system, the microprocessor checks the remaining life of the O₂ sensor whenever O₂ calibration @ 20.7% is performed. If the O₂ sensor declines to a certain level, REPL O₂ SNSR appears in the display and the visual alarm flashes. This alarm alerts the user to replace the O₂ sensor at the earliest convenience (Section 5). The unit will continue to function for some length of time.

O2 SNSR ERR

If the O₂ sensor declines to the point that control cannot be accurately performed, an O₂ SNSR ERR alarm sounds and control is disabled.

REPL IR SNSR

On units equipped with an IR CO₂ control system, calibration is performed automatically using an Auto Zero system. If this system cannot properly calibrate the sensor, the REPL IR SNSR alarm sounds. The unit will continue to function for some length of time.

CO2 SNSR ERR

If the cables or connectors between the main microprocessor board and the CO₂ sensor, or between the CO₂ board and the sensor head on I/R CO₂ units become loose or disconnected, the CO₂ SNSR ERR alarm occurs.

I/R Units

On I/R incubators, the red light on the I/R module (see Figure 5-4 for the module circuit board location) is lit continuously if communication is lost between the CO₂ board and the sensor head. The CO₂ display is locked at 00.0 without injection. Turning the incubator off and on will not clear the alarm. Only proper connections of all the components corrects the alarm.

IR AUTOZ ERR

On incubators equipped with I/R CO₂ control, calibration is performed automatically using an Auto Zero system. Auto Zero occurs once every 24 hours. If, during the Auto Zero cycle, a CO₂ correction of more than 0.45% is detected, the IR AUTOZ ERR alarm occurs.

Possible problems which will cause this alarm are:

- Auto Zero pump, orifice, filter or tubing will not allow air to the sensor.

Possibilities are:

- Defective or electrically disconnected air pump
- Kinked auto zero vinyl tubing
- Disconnected tubing between air pump and sensor
- Plugged filter or orifice on auto zero assembly
- Defective auto zero circuit
- Cabinet temperature has been increased significantly from a previous setpoint. (For example, the unit was calibrated and operating at 30°C and the setpoint is increased to 50°C) In this instance, calibrating the CO₂ will correct the alarm.
- There is high background CO₂ in the laboratory. This could be from leaks in the tank, regulator or vinyl CO₂ tubing.
- High CO₂ sensor calibration drift occurred. This requires replacement of the sensor.

Section 5 Routine Maintenance

Caution Before using any cleaning or decontamination method except those recommended by the manufacturer, users must check with the manufacturer that the proposed method will not damage the equipment. ▲

Cleaning the Interior

Warning If the units have been in service, disconnect the power cord connector before disinfecting. ▲

Use an appropriate disinfectant. All articles and surfaces must be thoroughly cleaned, rinsed and rough-dried.

Warning Alcohol, even a 70% solution, is volatile and flammable Use it only in a well ventilated area that is free from open flame. If any component is cleaned with alcohol, do not expose the component to open flame or other possible hazard. Allow the alcohol to fully dry before turning power on. ▲

Warning Do not spray the T/C sensor with flammable solutions. The internal temperature of the CO₂ sensor is approximately 150°C when the unit is in operation. Allow sufficient time for the sensor to cool before cleaning. ▲

Warning Do not use strong alkaline or caustic agents. Stainless steel is corrosion resistant, not corrosion proof. Do not use solutions of sodium hypochlorite (bleach), as they may also cause pitting and rusting. ▲

1. Turn the incubator off and disconnect the plug from the power source.
2. Remove the shelves, access port filter and side duct sheets. Remove the temperature sensors and the air sample filter tubing from the back of the blower scroll. If unit is equipped with the optional RH sensor, unfasten it from the clip on the top duct. See Figure 5-1.

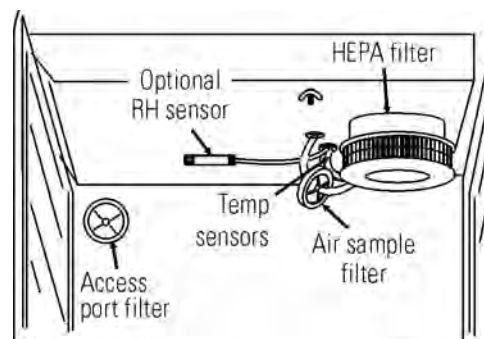

Figure 5-1. Sensor and Filter Locations

Cleaning the Interior (continued)

3. Remove the filter from the air sample filter tubing. Carefully pull down and remove the HEPA filter.
4. Remove the wingnuts securing the top duct to the interior. Carefully slide the top duct down and off the temperature sensor, air sample filter tubing (and RH sensor, if applicable).
5. Wash the shelves, ducts, wingnuts and stopper with disinfectant and rinse with sterile water. Option: Autoclave shelves, ducts and wingnuts.
6. Remove the blower scroll by first pushing the black lever clip closest to you toward the scroll. Then turn the scroll to the right to disengage it from the blower scroll plate. Some manipulation may be required as the alignment holes are keyhole-shaped.
7. Remove the remaining wingnut, then pull down on the blower wheel. If a new wheel and scroll are to be used, discard the old ones. If the old ones are to be reused, wash all parts with disinfectant and rinse with sterile water.
8. Remove the blower scroll plate by first pushing the black lever clip toward the chamber ceiling. Then turn the plate to the left to disengage it from the alignment keyholes. Clean as above, or autoclave.
9. Wash the cabinet interior with disinfectant starting at the top and working down. Wash the inner door both inside and out. The cabinet and door must be rinsed with sterile water until the disinfectant has been removed. After the cabinet has been rinsed, spray with 70% alcohol.
10. Reinstall the blower scroll plate by aligning it with the larger end of the keyholes and turning it to the left to lock it on. Pull the black lever clip downward from the ceiling.
11. Install the blower wheel onto the motor shaft, aligning the d-shaped flat sides of each. See Figure 5-2. Secure the blower wheel with the wingnut. Make sure the wheel turns freely.
12. Locate the blower scroll over the blower wheel into the larger end of the keyholes on the scroll plate. Turn the scroll to the right to lock it into the keyholes. Pull the black lever clip closest to you toward the front of the unit.

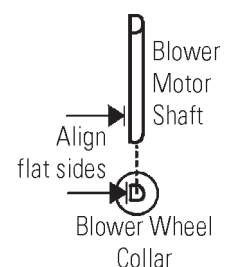

Figure 5-2. Align

Cleaning the Interior (continued)

13. Install the top duct by feeding the temperature sensors, air sample tubing (and RH sensor, if applicable) through the appropriate holes in the duct as it is raised to the top of the chamber. Be careful not to pull the grommets through the duct. See Figure 5-3.

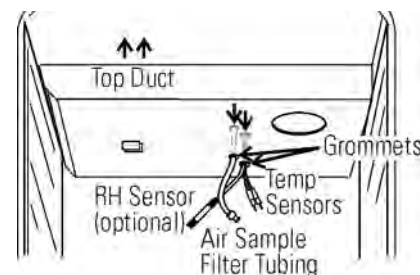

Figure 5-3. Feed Through Holes

14. Locate the mounting studs and blower scroll into the appropriate holes in the top duct and install the wingnuts to secure the duct.
15. Install the air sample filter onto the top duct tubing.
16. Carefully pull the temperature sensors and air sample filter tubing down until they can be inserted approximately 1 inch into the appropriate holes in the back of the blower scroll. If applicable, place the optional RH sensor into the corresponding clip on the top duct. See Figure 5-4.

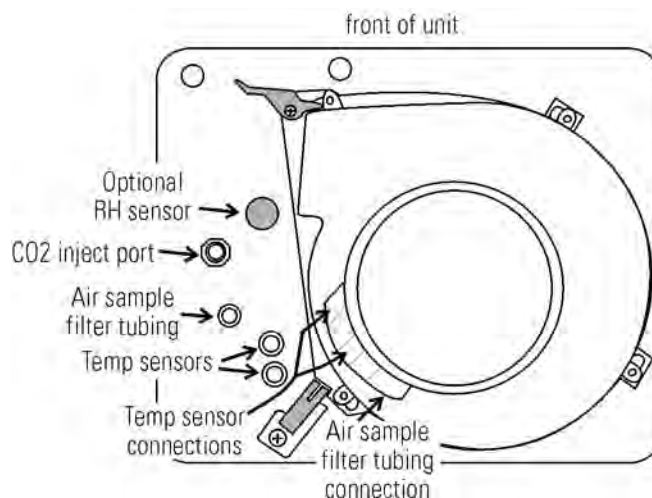

Figure 5-4. Underside View of Chamber Ceiling

17. Install the HEPA Filter.
18. Install the left and right ducts, and the access port stopper with filter, spraying each with 70% alcohol (do not saturate).
19. Install the shelves and spray with 70% alcohol.
20. Plug the incubator in and turn the power switch on. Allow the unit to run empty for 24 hours before returning to service.

Cleaning Cabinet Exterior

Clean the incubator exterior with a damp sponge or soft, well-wrung cloth and mild detergent dissolved in water. Dry with a soft cloth.

Cleaning Humidity Pan

Clean the humidity pan with soap and water and a general use laboratory disinfectant. Rinse with sterile water and spray with 70% alcohol. The humidity pan may be autoclaved.

Replacing Fuses

Warning The electronics drawer contains hazardous voltages. Replacing the fuses should be performed by qualified personnel only. ▲

Table 5-1. Fuses and Specifications

Fuse #	Manufacturer Part #	Amperage Rating	Rupture Speed	IEC Letter Code
F1	BUSS GMC-3.5A	3.5 Amp	Time-Lag	T
F4	BUSS GMC-2.5A	2.5 Amp	Time-Lag	T
115 VAC ACC	BUSS GMC-1.0A	1.0 Amp	Time-Lag	T
230 VAC ACC	BUSS BK-GMC-500mA	0.5 Amp	Time-Lag	T

There are three fuses in the incubator that can be replaced. To replace a fuse:

1. Turn off the incubator's power switch.
2. Unplug the power cord from the wall outlet.
3. Open the exterior cabinet door.
4. Remove two screws as shown. See Figure 5-5.
5. Carefully slide out electronics drawer.

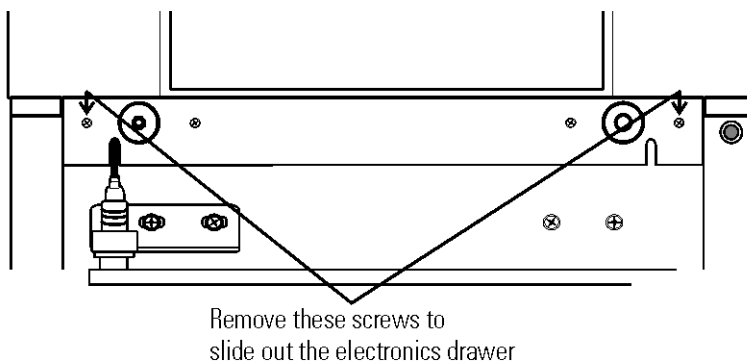

Figure 5-5. Screw Locations

Replacing Fuses (continued)

There are two fuses on the main microboard labeled F1 24VAC Door Heater and F4 24VAC Collar Heater. Refer to Figure 5-6 for the location of the main microboard. Remove the fuse and replace it with a new one of the same specification. Refer to Table 5-1.

The other replaceable fuse is the accessory outlet fuse mounted to the floor of the electronics drawer. To locate the fuse, refer to Figure 5-6. Remove the fuse and replace with a new one of the same specification.

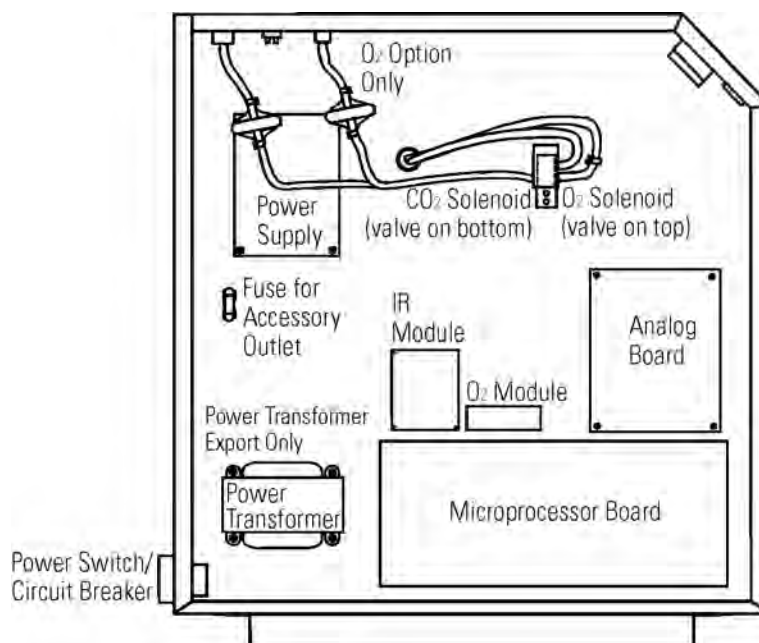

Figure 5-6. Electronics Drawer

1. When the fuse has been replaced, slide the electronics drawer back in, being very careful to place the door heater cable back into the provided slot so that the drawer does not pinch the cable.
2. Replace the two screws removed earlier.
3. Close the exterior door.
4. Plug the power cord back into the dedicated, grounded circuit.
5. Turn on power switch. If the unit operates properly, it may now be returned to service.

There is one fuse in the incubator that is not replaceable. This fuse is intended for catastrophic failure only and is located on the power supply circuit board in the electronics drawer. See Figure 5-6. If this fuse is blown, the power supply must be replaced. Contact the factory for more information.

HEPA Filter Maintenance

Replace the HEPA filter when the REPLACE HEPA reminder is displayed. The REPLACE HEPA reminder can be set to alarm after a specified time from 1 to 12 months. The reminder default is the factory recommended setting of 6 months. For details, see Section 3.

Replacing Air Sample Filter

The air sample filter should be replaced whenever the HEPA filter is replaced. On the inside of the chamber, inserted into the back of the blower scroll, is the air sample filter and its connecting tubing. Disengage the tubing from the back of the scroll, then remove the filter from the tubing and discard. Install the new filter. Connect it securely to the air sample filter tubing, then insert the tubing into the back of the blower scroll.

Replacing Access Port Filter

The access port filter should be replaced whenever the HEPA filter is changed. The filter is connected to the stopper in the upper left corner of the chamber back wall. Remove the filter from the connecting tube and discard. Install the new filter.

Draining Water Jacket

1. Turn the unit off. Remove the plug from the power source.
2. Remove the front cover plate below the door. There are small flatblade screwdriver pry slots on each end of the plate to help remove it. See Figure 5-7.

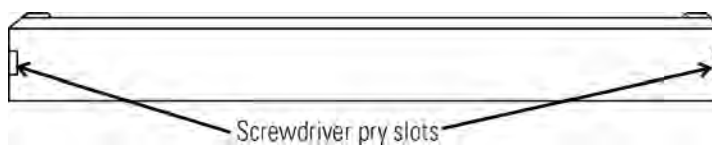

Figure 5-7. Front Cover Plate Below the Door

3. If present, remove the drain plug.
4. Connect the hose barb insert to the drain on lower front of the water jacket and to the drain hose.

Draining Water Jacket (continued)

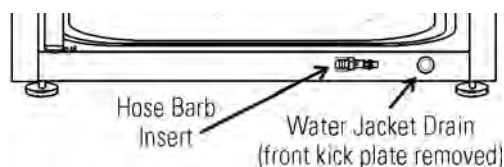

Figure 5-8. Water Jacket Drain and Hose Barb Insert

5. After water jacket has finished draining, remove the hose barb insert and secure on the front of the unit. See Figures 5-8 and 5-9.



Figure 5-9. Hose Barb Insert

6. Install cover plate.
7. To fill the water jacket, see Section 1. Be sure to add the rust inhibitor to the water when filling. For the proportions of rust inhibitor to water and the part number, see Section 5.

O₂ Sensor Fuel Cell - Models 3424, 3425, 3426, 3427

The O₂ sensor output declines over time, even if the unit is not in use. Replace the sensor every 30 months to ensure consistent output and to prevent the possibility of failure in the middle of a test experiment.

Replacing O₂ Sensor - Models 3424, 3425, 3426, 3427

The O₂ sensor is located on the blower scroll plate in the chamber of the unit. To replace it, refer to Figure 5-10 and 5-12 and follow steps below.

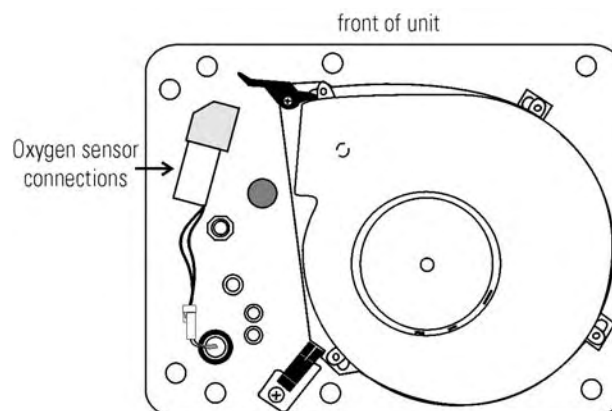

Figure 5-10. Underside View of Top of Chamber

1. Turn the unit off and disconnect the plug from the power source.
2. Remove the top duct by removing 2 wingnuts.
3. Locate the sensor on the scroll plate.

Replacing O₂ Sensor (continued)

4. Lift up slightly on the tab securing the sensor wire terminal connection. Be careful not to break the tab off. See enlarged detail of Figure 5-11.
5. Disconnect the terminals from each other. Note the orientation of the terminals.
6. The O₂ sensor is screwed into the brass fitting. Unscrew the old sensor and discard.
7. Screw the new sensor in firmly. Be careful not to cross-thread.
8. Orient the terminals as previously and connect.
9. Install the top duct and tighten the 2 wingnuts.
10. Plug the unit in. Calibrate the O₂ system using the O₂ CAL@20.7% method as described in Section 2.
11. Allow the unit to run until the temperature stabilizes. Check the O₂ and CO₂ operation and return the unit to service.

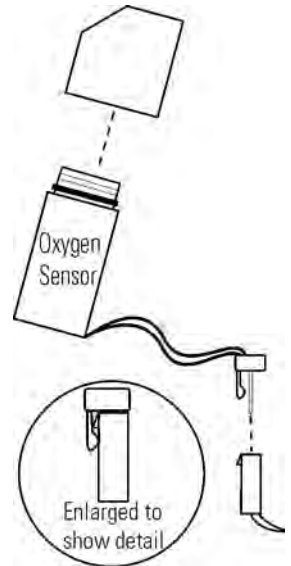

Figure 5-11. Detail

Adding /Replenishing Rust Inhibitor

The Series 8000WJ incubators are shipped from the factory with a rust inhibitor added to the water in the jacket. This inhibitor must be replenished every 2 years. Mix 1 bag/bottle of the rust inhibitor with a gallon of distilled, de-mineralized, or de-ionized water. Drain a gallon of water from the jacket and replace it with the rust inhibitor mixture.

Rust Inhibitor 0.5 lb. (225g) bag 1900100

Reversing the Door Swing

For side-by-side operation or changing lab layouts, the inner and outer doors are field-reversible. The procedure is written from the prospective of changing the door swing from a left-hand to a right-hand swing. All screw holes are pre-drilled for reversing the door. The tools required are a Phillips and a flatblade screwdriver.

Warning If the units have been in service, disconnect the power cord connector before reversing the door swing. ▲

Reversing the Hinges for the Exterior Door

1. Referring to Illustration A following, open the outer door and remove it by lifting it off the hinge pins. Lay this door down on its face on a padded surface to prevent scratches.
2. Remove the two outer door hinges identified in the illustration.
3. Remove the four nylon screws from what will be the new locations for the inner door hinges.
4. With the Phillips screwdriver, remove and save the four nylon screws from the outer door hinge mounting holes on the right side of the door frame.
5. Remove the electrical connector on the top of the inner door hinge by carefully prying up the black strain relief.
6. Refer to Figure 5-12. The heater wiring connector is of yellow rubber which should be visible when the strain relief is moved upward as shown. See connector manufacturer's instructions in Appendix A of this manual.
7. Grasp the upper portion of the yellow connector and pull it up and out of the hinge socket.

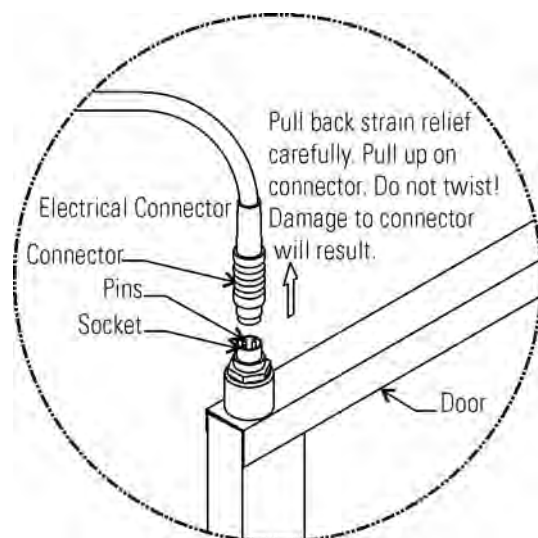

Figure 5-12. Connector

Reversing Hinges for the Exterior Door (continued)

8. Remove the inner door upper hinge. This hinge will be inverted and become the lower inner door hinge when the hardware is reassembled. When removing the door, set it aside on a flat surface, taking care not to damage the electrical sockets on the top and bottom of the door frame. At this time, remove the 5/8" black plastic bushing from the hinge. This bushing will be inserted in the top hinge when the door is installed on the right side of the cabinet.

Warning The frame along the hinge side of the inner glass door has electrical connectors mounted on the frame at both the top and bottom of the door. Be careful not to damage the connectors by resting the weight of the door on them. Place the inner glass door on a flat surface where it cannot be damaged before moving on to the next step. ▲

9. Remove the lower inner door hinge. Note that this hinge will be inverted and become the upper inner door hinge when the hardware is reassembled. Also, remove the 1" long white plastic bushing from the center of the hinge and insert it into the hinge removed in step above.
10. The shoulder of the bushing must be on top as shown in Illustration B. Install the black plastic bushing into the hinge just removed and which will be the top hinge when the door is reversed. See Figure 5-12.
11. Remove the two nylon screws opposite the door latch.
12. Remove the door strike plate and install the two nylon screws just removed (Step 11) into the vacant holes.
13. Remove the two outer Phillips screws on the frame just beneath the control panel. Remove only the two outer screws and pull the electronics tray out about one inch.

Refer to Illustration B.

14. Verify that the nylon screws have been installed in the vacant door strike holes.
15. Move the door heater cable to the slot on the right side of the tray.
16. Push any excess cable into the tray area, making sure the wire will not be damaged when the tray is pushed back in and secured.
17. Install the lower inner door hinge in the drawing. (This was the top inner door hinge removed in Step 7 and should have the white plastic bushing installed.) Do not completely tighten the screws.

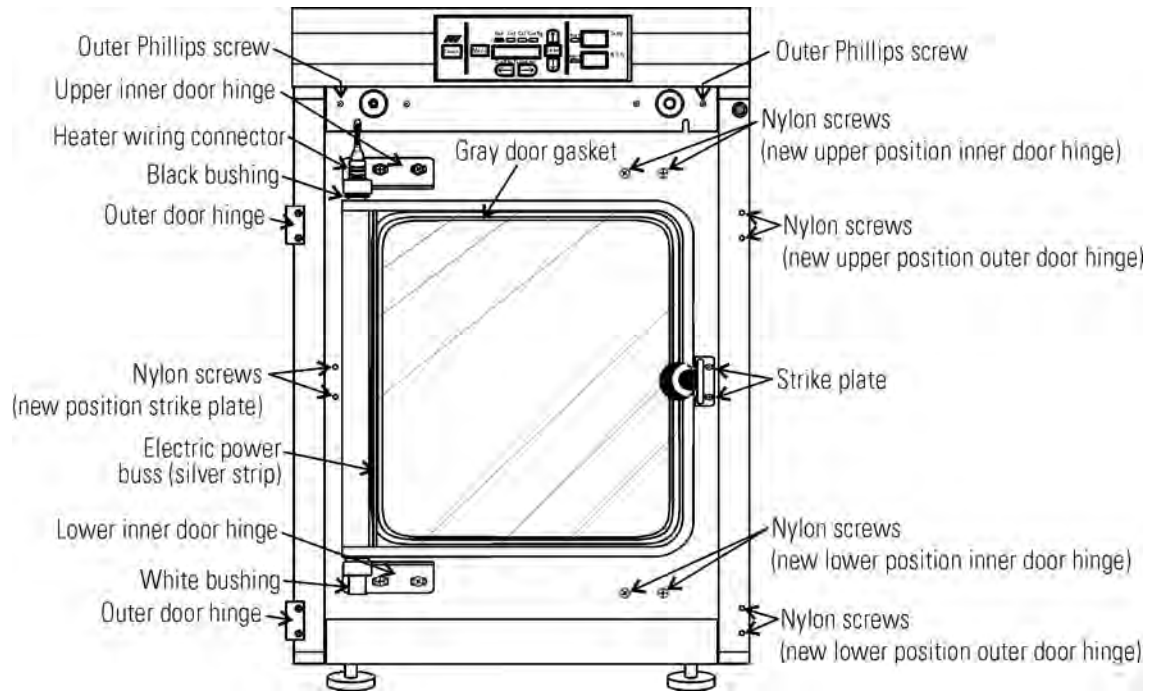

Illustration A. Disassembly

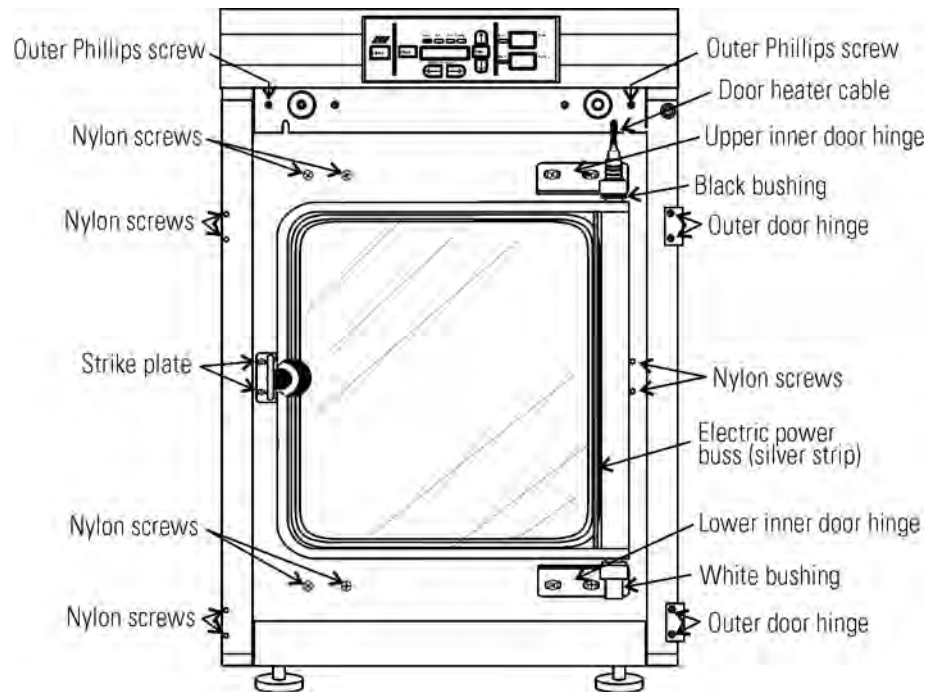

Illustration B. Reassembly

Reversing Hinges for the Exterior Door (continued)

18. Insert the inner door into the lower hinge with the latch to the left.
Align the door to chamber opening and place upper hinge in position.

19. Insert the screws into the hinge but do not completely tighten them.

20. Match the pins on the yellow connector with the socket on the door. Press the connector completely into the socket and slide the strain relief down until no yellow is visible on the plug (Figure 5-13).

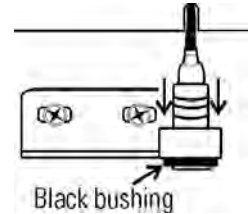

Figure 5-13. Bushing

21. Push the power cable completely into the slot in the electronics tray.
Press the tray into position and secure it with the screws.

22. Align the silver power buss visible through the glass along the hinge side of the door with the gasket along right side of chamber opening.

23. When both hinges are in place with the hinge screws still loosened, push up on the bottom hinge. This will shift both hinges and the door upward. Tighten the hinge screws.

24. Attach the strike plate, aligning it so the knob secures the door against the gasket.

25. Attach the outer door hinges.

26. Install the nylon screws in the previously upper and lower outer hinge locations.

27. Install the nylon screws in the previously upper and lower inner hinge locations. Assemble the outer door to the incubator and return the unit to service.

PREVENTIVE MAINTENANCE

Incubators

Your equipment has been thoroughly tested and calibrated before shipment. Regular preventive maintenance is important to keep your unit functioning properly. The operator should perform routine cleaning and maintenance on a regular basis. For maximum performance and efficiency, it is recommended the unit be checked and calibrated periodically by a qualified service technician.

The following is a condensed list of preventive maintenance requirements. See the specified section of the operating manual for further details.

We have qualified service technicians, using NIST traceable instruments, available in many areas. For more information on Preventive Maintenance or Extended Warranties, please contact us at the number listed below.

Cleaning and calibration adjustment intervals are dependent upon use, environmental conditions and accuracy required.

Tips for all incubators:

- Do NOT use bleach or any disinfectant that has high chloros
- Use sterile, distilled or demineralized water.
- Avoid spraying cleaner on the CO₂ sensor.
- Do not use powdered gloves for tissue cultures.

Preventive Maintenance for Water Jacket Incubators

Action	Daily	Weekly	Monthly	6 Months	Yearly	2 years
Check CO ₂ tank levels.	✓					
Inspect door latch, hinges and door gasket seal.					✓	
Check water level in the humidity pan, ½” from top. See “Filling the Humidity Pan”.		✓				
Verify and document CO ₂ , O ₂ , humidity and temperature calibration, as applicable. See Calibration section					✓	
Perform a complete decontamination procedure. Wipe down interior, shelves and side ducts with disinfectant. Change or clean blower wheel and scroll. Clean top duct. Clean humidity pan. Rinse everything well with sterile distilled water. See “Cleaning the Interior, “Cleaning the Humidity Pan”.	Between experiments <i>More frequent decontamination may be required, depending on use and environmental conditions</i>					
Change HEPA and gas filters, if applicable (<i>or as needed</i>). See “Installing Air Sample Filter”, “Installing HEPA Filter”.				✓		
Replenish rust inhibitor in water jacket. See “Adding/Replenishing Rust Inhibitor”.						✓
Replace AquaTec water cleaning cell, if applicable.				✓		

Section 6 Factory Installed Options

A description of the factory installed options follows.

Humidity Readout

All Series 8000WJ incubators can be equipped with a humidity sensor to monitor the relative humidity (RH) inside the chamber. The sensor is mounted to the top air duct and provides a signal that is displayed in 1% increments on the control panel. The humidity readout can be displayed continuously or toggles with the temperature readout. In addition, a low alarm limit can be set on the humidity readout which will detect when the humidity pan runs dry. Refer to Section 3, Configuration.

Factors Affecting Humidity Level in Chamber:

- Water level in the humidity pan
- Frequency of door openings
- Humidity pan location; floor, shelf, in duct
- Air leakage through the gaskets
- Gas sample port capped
- N₂ purge on incubators with O₂ control.
- Humidity levels in O₂ units will be reduced, depending on the amount of N₂ required to control the O₂ level in the chamber.

The table at right lists some typical RH levels at different O₂ and CO₂ percentages.

Table 6-1. Typical RH levels

O ₂ %	CO ₂ %	RH% (±5%)
1%	2.5%	55%
2%	5%	60%
5%	10%	75%
10%	10%	80%
21%	5%	95%

Incubators equipped with a Thermal Conductivity CO₂ sensor rely on a constant level of relative humidity in order to accurately measure and control the CO₂ concentration in the incubator.

The sensor is capable of measuring relative humidity from 10% to 100% with an accuracy of ±5% above 90%. See Section 2, Calibration for details on calibrating the humidity readout.

Remote Alarm Contacts



A set of relay contacts are provided to monitor alarms through an RJ-11 telephone style connector on the back of the cabinet. Refer to Figure 1-13 for the location of the alarm connector.

The remote alarm provides a NO (normally open) output, a NC (normally closed) output and COM (common). Refer to Figure 6-1.

The contacts will trip on a power outage or an over temperature condition. The contacts may also be programmed to trip or not trip on temperature alarms, CO₂ alarms, O₂ alarms, and RH alarms. See Section 3, Configuration.

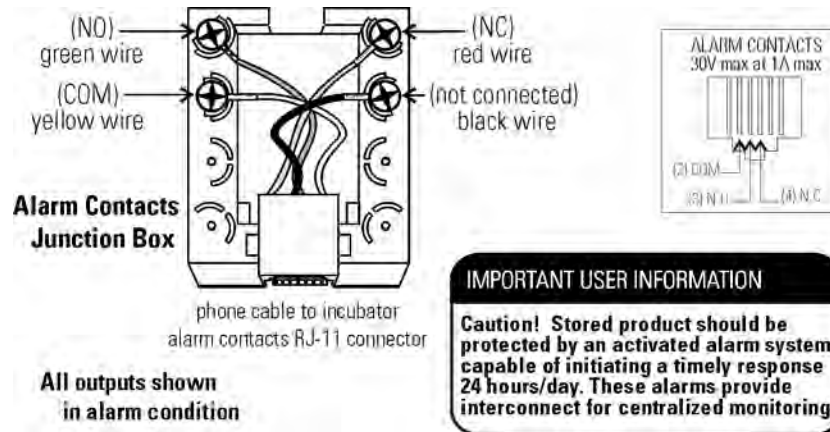

Figure 6-1. Contacts

Section 7 Specifications

*Specifications are based on a nominal voltage of 115V in an ambient of 22°C to 25°C.

Temperature

Control	±0.1°C
Range	+5°C above ambient to +55°C (131°F)
Uniformity	±0.2°C @ +37°C
Tracking Alarm	User programmable high/low

Temperature Safety

Sensor	Precision thermistor
Controller	Independent analog electronic
Setability	0.1°C

CO₂/O₂

CO ₂ /O ₂ Control	Better than ±0.1%
CO ₂ Range	0-20%
O ₂ Range	1-20%
Inlet Pressure	15 PSIG (1.034 bars)
CO ₂ Sensor	T/C or IR
O ₂ Sensor	Fuel Cell
Readability	0.1%
Setability	0.1%
Tracking Alarm	User programmable

Humidity

RH	Ambient to 95% @ +37°C (98.6°F)
Humidity Pan	0.8 gal. (3 liters) standard
Optional	Display in 1% increments

Fittings

Fill Port	3/8" barbed
Drain Port	1/4" barbed
Access Port	1-1/4" (3.18cm) removable neoprene plug
CO ₂ Inlet	1/4" hose barbed

Unit Heat Load

115V/230V 344 BTUH (100 Watt)

Shelves

Dimensions	18.5" x 18.5" (47.0cm x 47.0cm)
Construction	Stainless steel, perforated, electropolished
Surface area	2.4 sq. ft. (0.22 sq. m) per shelf
Max. per Chamber	38.4 sq. ft. (3.6 sq. m)
Loading	35 lbs (16kg) slide in and out, 50 lbs (23kg) stationary
Standard	4
Maximum	16

Construction

Water Jacket Volume	11.7 gal. (43.5 liters)
Interior Volume	6.5 cu. ft. (184.1 liters)
Interior	Type 304, mirror finish, stainless steel
Exterior	18 gauge, cold rolled steel, powder coated
Outer Door Gasket	Four-sided, molded magnetic vinyl
Inner Door Gasket	Removable, cleanable, feather-edged, silicone

Electrical

Specifications	90-125VAC, 50/60 Hz, 1 PH, 3.6 FLA
Circuit Breaker/Power Switch	6 Amp/2 Pole
Convenience Receptacle	75 Watts max. (one per chamber)
Alarm Contacts	Power interruption, deviation of temp., CO ₂ , O ₂ , and RH, customer connections through jack on back of unit. 30V, 1A max.
Installation Category	Overvoltage Category II Pollution Degree 2
Maximum Leakage Current	With ground disconnected, 0.65mA Maximum permissible leakage, 3.5mA

Dimensions

Interior	21.3" W x 26.8" H x 20.0" F-B (54.1cm x 68.1cm x 50.8cm)
Exterior	26.3" W x 39.5" H x 25.0" F-B (66.8cm x 100.3cm x 63.5cm)

Weight (per unit)

Net	265 lb. (120.2 kg)
Net Operational	365 lb. (165.6 kg)
Shipping	324 lb. (147.0 kg)

Safety Specifications

Altitude	2000 meters
Temperature	5°C to 40°C
Humidity	80% RH at or below 31°C, decreasing linearly to 50% RH at 40°C
Mains Supply Fluctuations	Operating Voltage Range
Installation Category	2 ¹
Pollution Degree	2 ²
Class of Equipment	

¹ Installation category (overvoltage category) defines the level of transient overvoltage which the instrument is designed to withstand safely. It depends on the nature of the electricity supply and its overvoltage protection means. For example, in CAT II which is the category used for instruments in installations supplied from a supply comparable to public mains such as hospital and research laboratories and most industrial laboratories, the expected transient overvoltage is 2500V for a 230V supply and 1500V for a 120V supply.

² Pollution Degree describes the amount of conductive pollution present in the operating environment. Pollution Degree 2 assumes that normally only non-conductive pollution such as dust occurs with the exception of occasional conductivity caused by condensation.

Unit Attachment Location

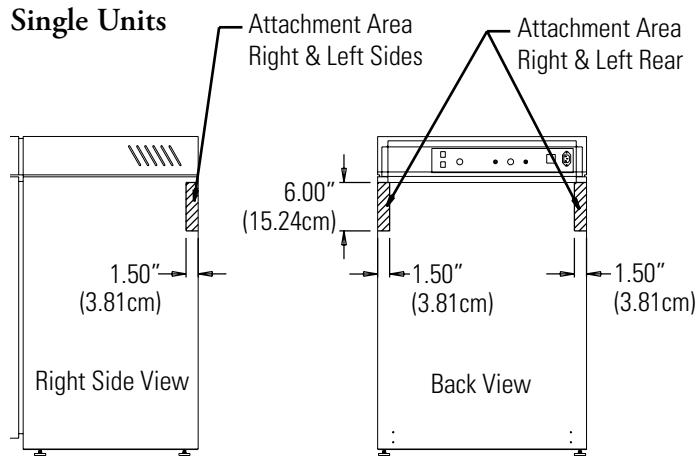

Caution Do not drill deeper than 1/2 inch.
Exterior wrap is 18 ga. cold rolled steel. ▲

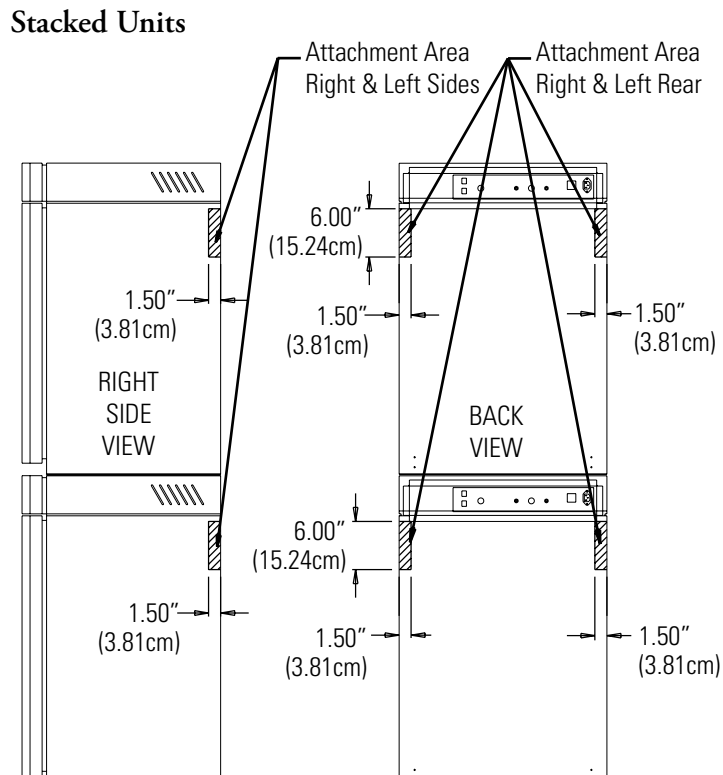

Unit Center of Gravity Locations

Single Units

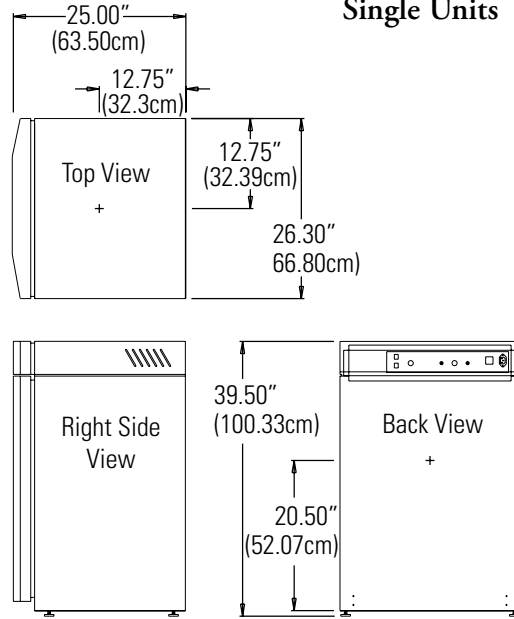

Stacked Units

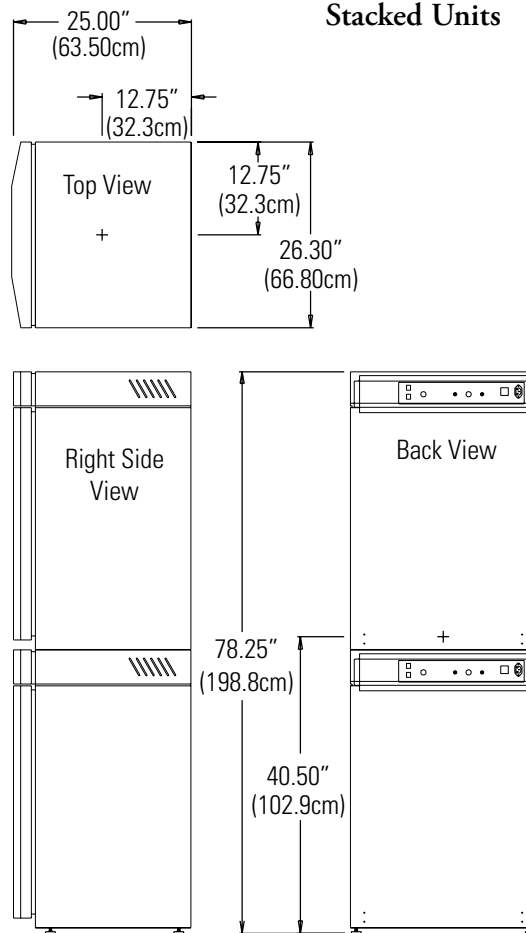

Section 8 Spare Parts

All Models	Part #	Description
	360171	Liquid Level Switch
	103065	Feather Gasket
	113002	5/16-18 Glide Foot
	132046	115/230V Dual Heater
	132056	Face Heater 27W, 24VAC
	190730	Heated Inner Door
	190650	Heated Inner Glass Door Kit (8 doors)
	190619	Left Inner Door Hinge
	190646	Door Lock for Inner Glass Door
	190666	Right Hand Door Swing
	700013	0.500" Flanged Nylon Bearing
	990026	Door Gasket w/ Magnet
	290184	Temp Probe 2252 Ohm
	191634	Micro Board Assembly
	1900346	Display Board Assembly
	230153	6A Circuit Breaker/Switch
	460157	Line Filter/Power Inlet
	420096	130VA Transformer, Int'l, 14/28V S
	230135	1 AMP Fuse for 115V Outlet
	230159	3.5 Amp Fuse - Microboard
	230158	2.5 Amp Fuse - Microboard
	250087	Solenoid Valve Kit w/assorted fittings
	156126	Motor 2-Pole 115VAC
	100113	Blower Wheel 3.5x1.5 CCW
	190846	Blower Scroll Assembly
	103072	Blower Plate Gasket
	290090	CO ₂ Sensor Assembly
	103074	CO ₂ Sensor Plate Gasket
	965010	CO ₂ Gas Regulator
	961027	N ₂ Gas Regulator

All Models (continued)

Part #	Description
950316	Wall Clamp for CO ₂ Bottle
130097	#6 Silicone Stopper w/ 3/8" Hole
180001	Polypropylene Funnel
430108	Line Cord Set
110084	Drain Plug
770001	Bacterial Air Filter (CO ₂ line, air, sample and access port)
760175	HEPA Filter
760209	HEPA Filter Value Pack (4 pack)
1900067	Filter Replacement Kit ([2] 770001 filter and 760175 HEPA)
760210	In-line Filter Value Pack (P/N 770001-10 pack)
190651	Decontamination Kit
50109579	AquaTec water cleaning cell 4-pack (for water reservoirs, pans, and bottles)
3166242	Gas Shuttle Switch
3050	External Gas Guard
190884	Stainless Steel Shelf and Channels
190647	Roller Base
190648	Floor Stand
140387	Overlay
1900346	Display Control Board

230V Units

420097	43VA Transformer, INT. SR
460138	Power Outlet, Snap-in Receptacle,
230120	0.5A Fuse for 230V Outlet

IR or O₂ Units

190885	IR Sensor
191646	O ₂ Circuit Board
250119	AC Solenoid
770001	Filter
250118	Valve, Sol, O ₂ , 12VDC, 4W
290083	O ₂ Sensor Fuel Cell
190661	IR Sensor Filter

Humidity Readout Units

290154	RH Sensor Assembly, 1 ft.
--------	---------------------------

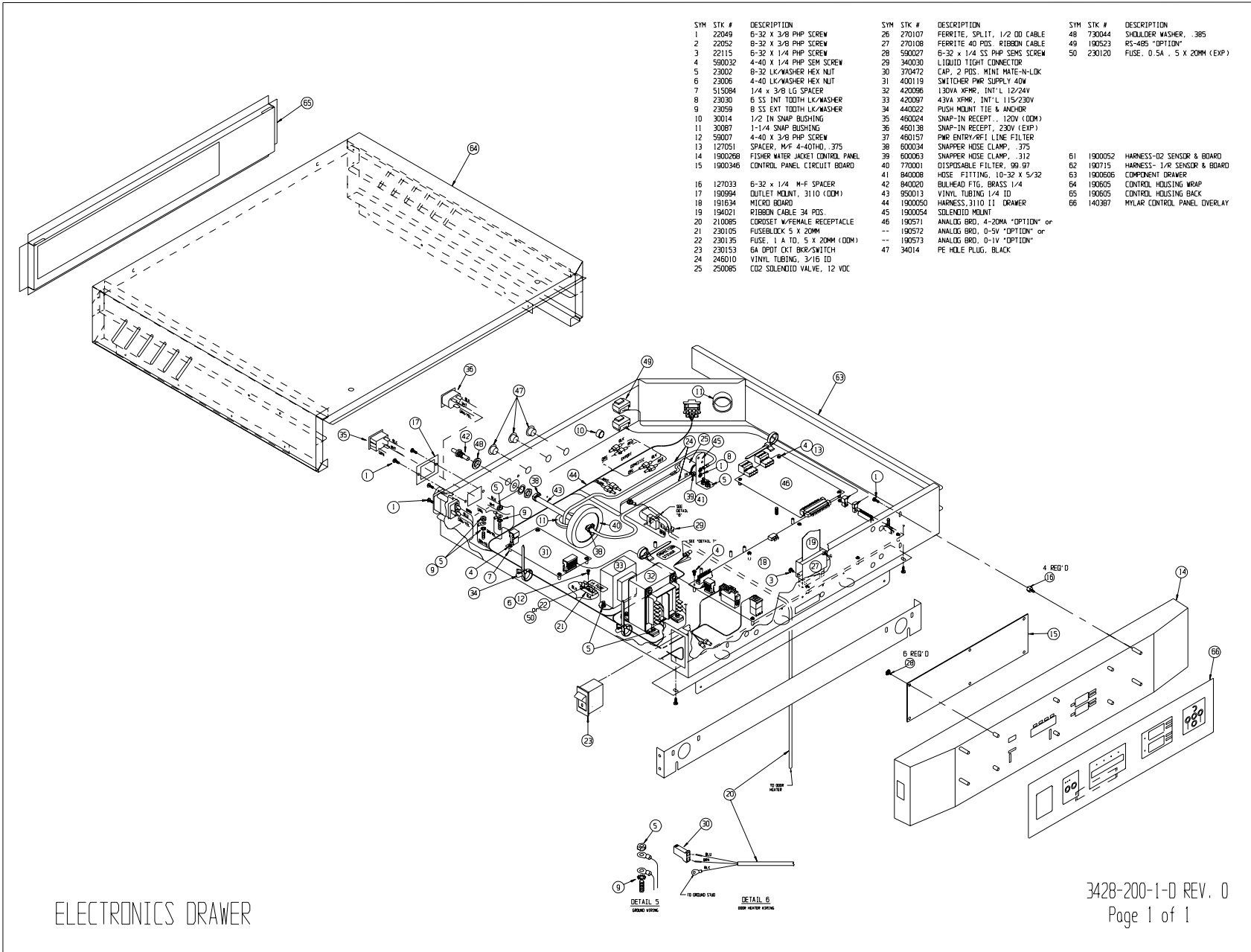

SYM	STK #	DESCRIPTION	SYM	STK #	DESCRIPTION	SYM	STK #	DESCRIPTION
1	22049	6-32 X 3/8 PHP SCREW	26	270107	FERRITE, SPLIT, 1/2 OD CABLE	48	730444	SHOULDER WASHER, .385
2	22052	8-32 X 3/8 PHP SCREW	27	270108	FERRITE 40 POS. RIBBON CABLE	49	190523	RS-485 "OPTION"
3	22115	6-32 X 1/4 PHP SCREW	28	590027	6-32 X 1/4 SS PHP SEMS SCREW	50	230120	FUSE, 0.5A, 5 X 20MM (EXP)
4	590032	4-40 X 1/4 PHP SEM SCREW	29	340030	LIQUID TIGHT CONNECTOR			
5	23002	8-32 LK WASHER HEX NUT	30	370472	CAP, 2 POS. MINI MATE-N-LOK			
6	23006	4-40 LK WASHER HEX NUT	31	400119	SWITCHER PWR SUPPLY 40W			
7	515084	1/4 X 3/8 LG SPACER	32	420086	130VA XFRM, INT'L 12/24V			
8	23030	8 SS INT TOOTH LK WASHER	33	420097	43VA XFRM, INT'L 115/230V			
9	23059	8 SS EXT TOOTH LK WASHER	34	440022	PUSH MOUNT TIE & ANCHOR			
10	30014	1/2 IN SNAP BUSHING	35	460024	SNAP-IN RECEPT., 120V (ODM)			
11	30087	1-1/4 SNAP BUSHING	36	460138	SNAP-IN RECEPT., 230V (EXP)			
12	590077	4-40 X 3/8 PHP SCREW	37	460157	PWR ENTRY/EXIT LINE FILTER			
13	127051	SPACER, W/F 4-40THD, .375	38	600024	SNAPPER HOSE CLAMP, .375			
14	1900268	FISHER WATER JACKET CONTROL PANEL	39	600063	SNAPPER HOSE CLAMP, .312	61	1900052	HARNESS-02 SENSOR & BOARD
15	1900346	CONTROL PANEL CIRCUIT BOARD	40	770001	DISPOSABLE FILTER, 99.97	62	1900715	HARNESS-1/R SENSOR & BOARD
16	127023	6-32 X 1/4 W-F SPACER	41	840008	HOSE FITTING, 10-32 X 5/32	63	1900606	COMPONENT DRAWER
17	1900994	OUTLET MOUNT, 3110 (ODM)	42	840020	BULHEAD FIT, BRASS 1/4	64	1900605	CONTROL HOUSING WRAP
18	191634	MICRO BOARD	43	950013	VINYL TUBING 1/4 ID	65	1900605	CONTROL HOUSING BACK
19	194021	RIBBON CABLE 34 POS.	44	1900050	HARNESS, 3110 I1 DRAWER	66	140387	MYLAR CONTROL PANEL OVERLAY
20	210085	CORSET W/FEMALE RECEPTACLE	45	1900054	SOLENOID MOUNT			
21	230105	FUSEBLOCK 5 X 20MM	46	190571	ANALOG BRD, 4-20MA "OPTION" or			
22	230135	FUSE, 1 A TO, 5 X 20MM (ODM)	--	190572	ANALOG BRD, 0-5V "OPTION" or			
23	230153	6A DPDT CKT BKR/SWITCH	--	190573	ANALOG BRD, 0-1V "OPTION"			
24	246010	VINYL TUBING, 3/16 ID	47	34014	PE HOLE PLUG, BLACK			
25	250085	CO2 SOLENOID VALVE, 12 VDC						

3428-200-1-D REV. 0
Page 1 of 1

Section 8
Spare Parts

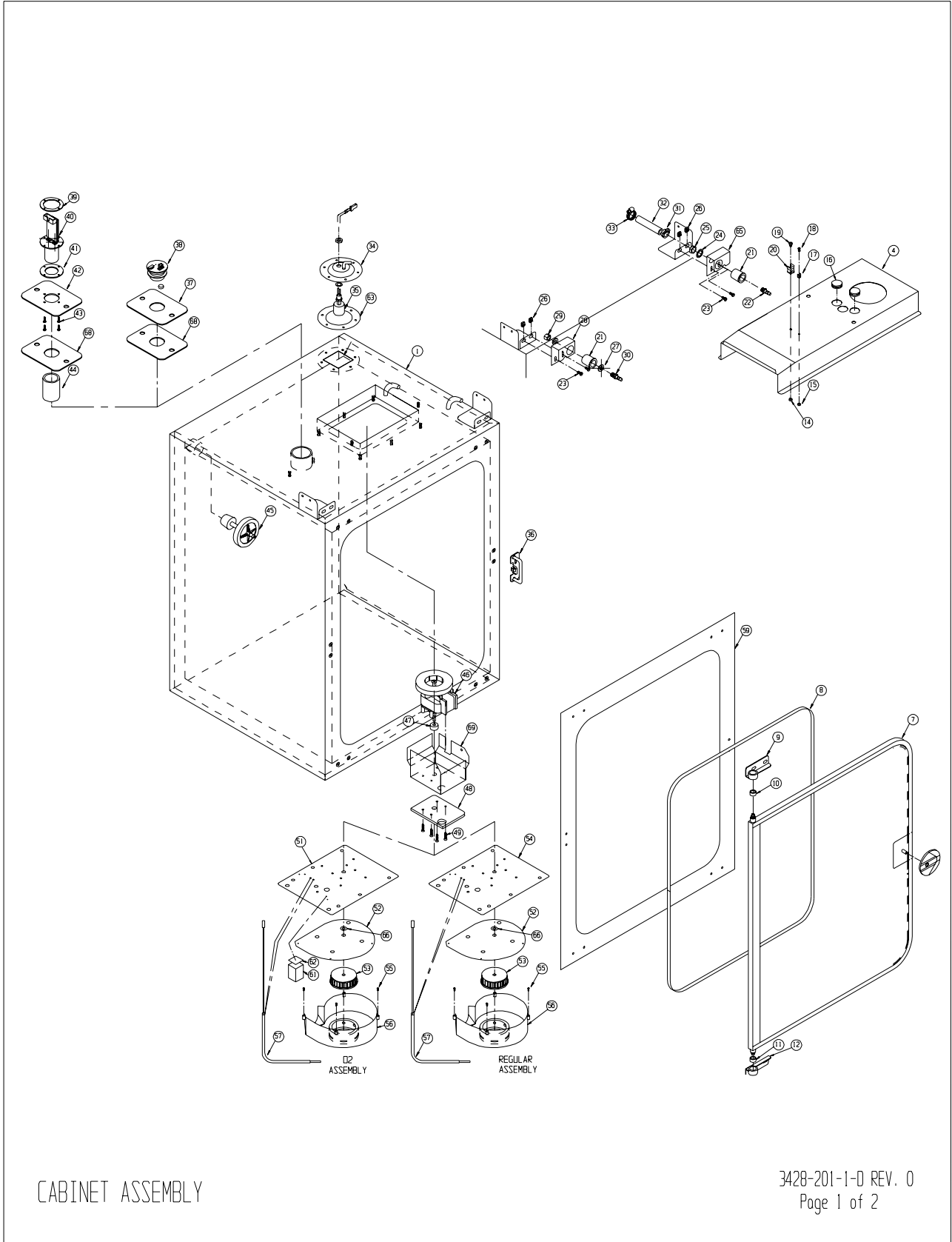

SYM	STK #	DESCRIPTION
1	1900600	WATER JACKET CHAMBER
2	190723	INTERIOR DUCT SHEETS
3	190664	SHELF CHANNELS
4	1900056	TOP DUCT(1900057 COPPER)
5	224175	SHELF
6	-----	-----
7	190730	INNER GLASS DOOR
8	103108	INNER DOOR GASKET
9	190618	TOP INNER DOOR HINGE
10	700013	TOP INNER DOOR HINGE BUSHING
11	700046	BOTTOM INNER DOOR HINGE BUSHING
12	190619	BOTTOM INNER DOOR HINGE
13	180210	INNER DOOR KNOB
14	23010	8-32 SS NUT
15	23005	4-40 SS NUT
16	114022	15/16 BLIND GROMMET
17	111022	1/4" PROBE CLIP
18	22130	4-40 X 1/4 SS SCREW
19	22051	8-32 X 1/4 SS SCREW
20	111007	13/32 RH PROBE CLIP
21	190294	FILL PORT ACCESS
22	840043	PLASTIC HOSE BARB
23	680013	8 X 1/2 SS SCREW TYPE B
24	290128	1/2" LOCK WASHER
25	840043	NUT (PART OF #22)
26	3178097	#8 SPEED NUT
27	730060	SEAL WASHER
28	190675	LEFT MOUNT
29	840035	3/16 ADAPTER
30	840065	1/4 HOSE BARB
31	600065	SNAPPER CLAMP
32	246011	3/8 VINYL TUBING
33	600055	SS HOSE CLAMP
34	190306	FLOAT SWITCH MOUNT
35	360171	FLOAT SWITCH

SYM	STK #	DESCRIPTION
36	190634	INNER DOOR LATCH
37	190649	TC SENSOR PLATE
38	290090	TC SENSOR
39	190712	IR MOUNTING RING
40	190708	"DCS" IR SENSOR
41	103083	IR SENSOR GASKET
42	190711	IR MOUNTING PLATE
43	22130	4-40 X 1/4 SS SCREW
44	190708	IR SENSOR FILTER (PART OF ITEM 40)
45	190985	FILTERED STOPPER ASSEMBLY
46	156126	BLOWER MOTOR
47	730069	MOTOR SHAFT SEAL
48	190655	MOTOR SPACER PLATE
49	590023	8-32 X 3/4 SS SCREWS
50	-----	-----
51	1900055	O2 BLOWER PLATE ASSY
52	190893	SCROLL PLATE
53	100113	BLOWER WHEEL "O" SHAFT
54	1900053	STANDARD BLOWER PLATE
55	22134	6-32 X 1/2 "FILISTER" HEAD SCREW
56	190846	BLOWER SCROLL
57	290184	TEMPERATURE PROBE
58	760175	HEPA FILTER
59	180174	PVC FACE FRAME
60	237016	HUMIDITY PAN
61	1900058	BRASS O2 BLOCK
62	100064	BRASS BLOCK SEAL
63	103032	FLOAT SWITCH GASKET
64	23024	3/8 FLAT WASHER
65	190675	RIGHT MOUNT
66	730068	TEFLON WASHER
67		
68	103074	SENSOR PLATE SEAL
69	1900249	MOTOR SHIELD & GUARD

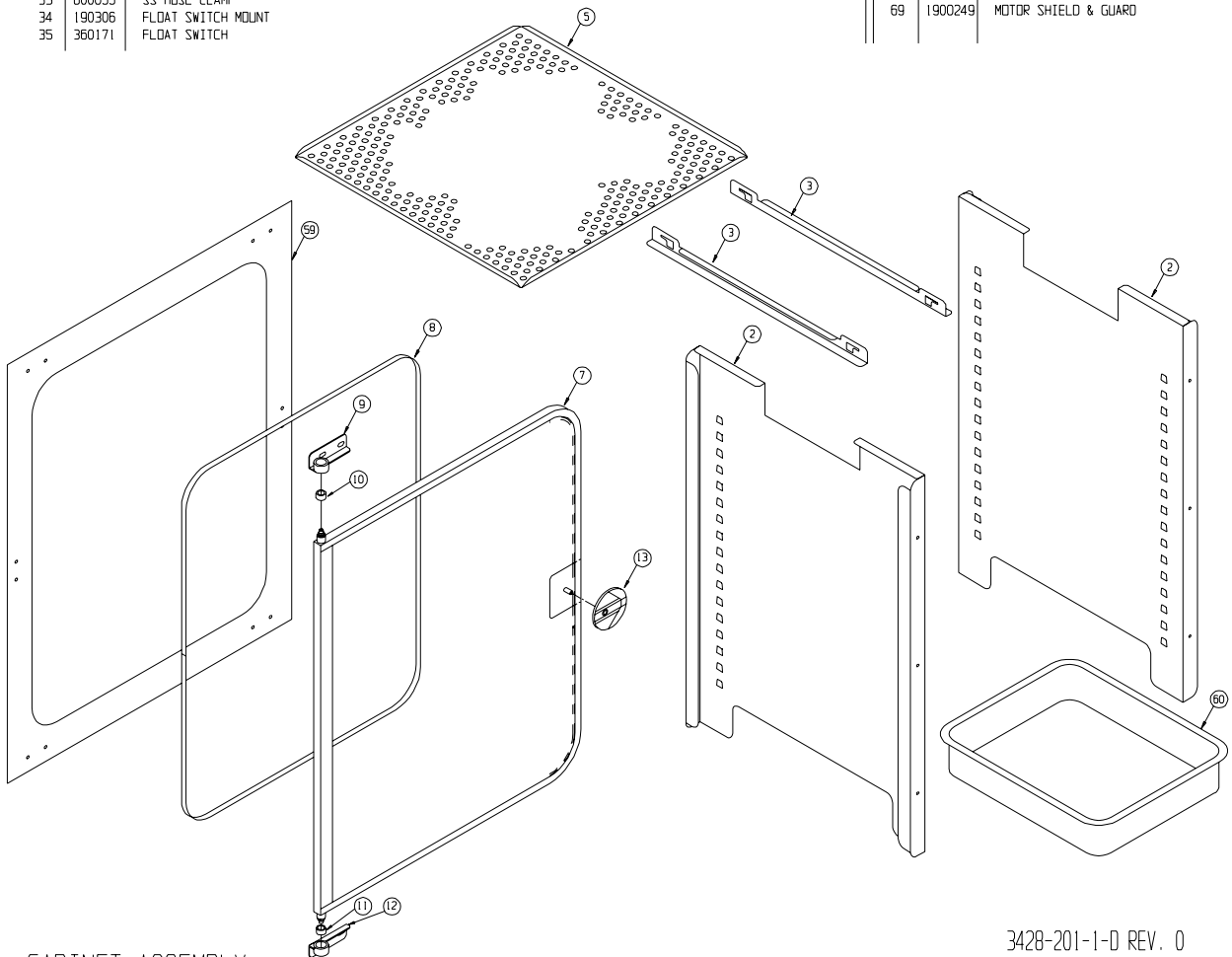

CABINET ASSEMBLY

3428-201-1-D REV. 0
Page 2 of 2

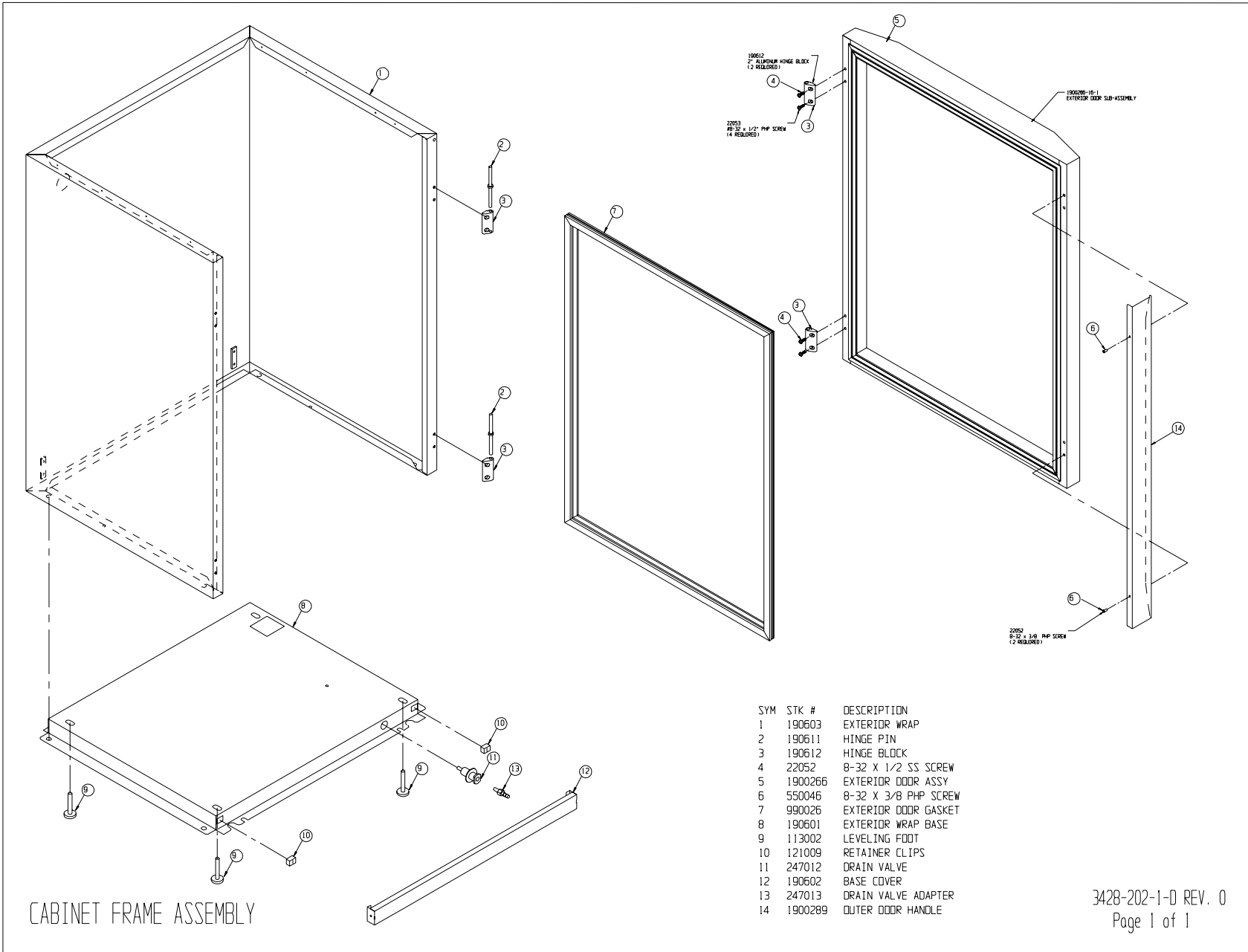

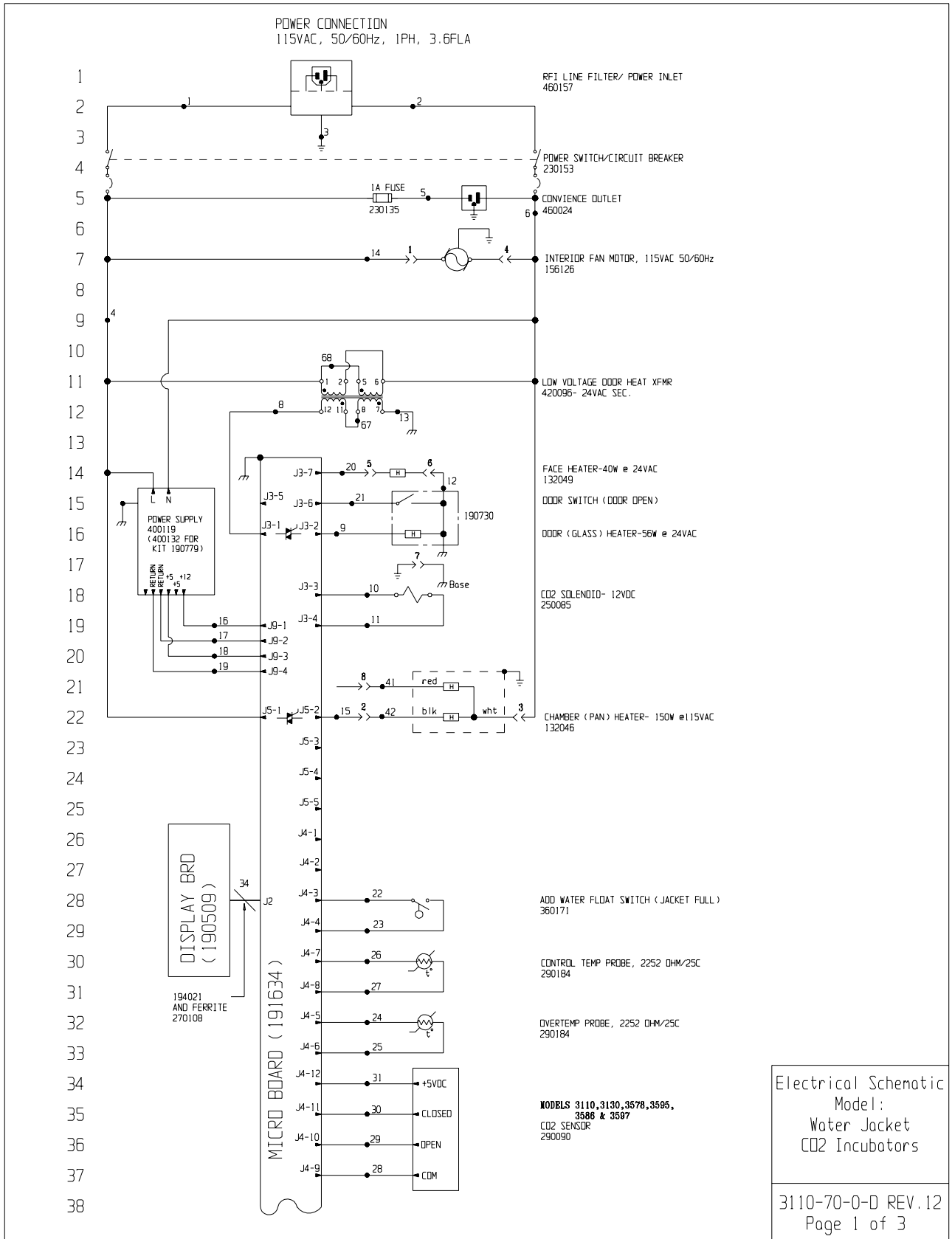

Section 9
Electrical Schematics

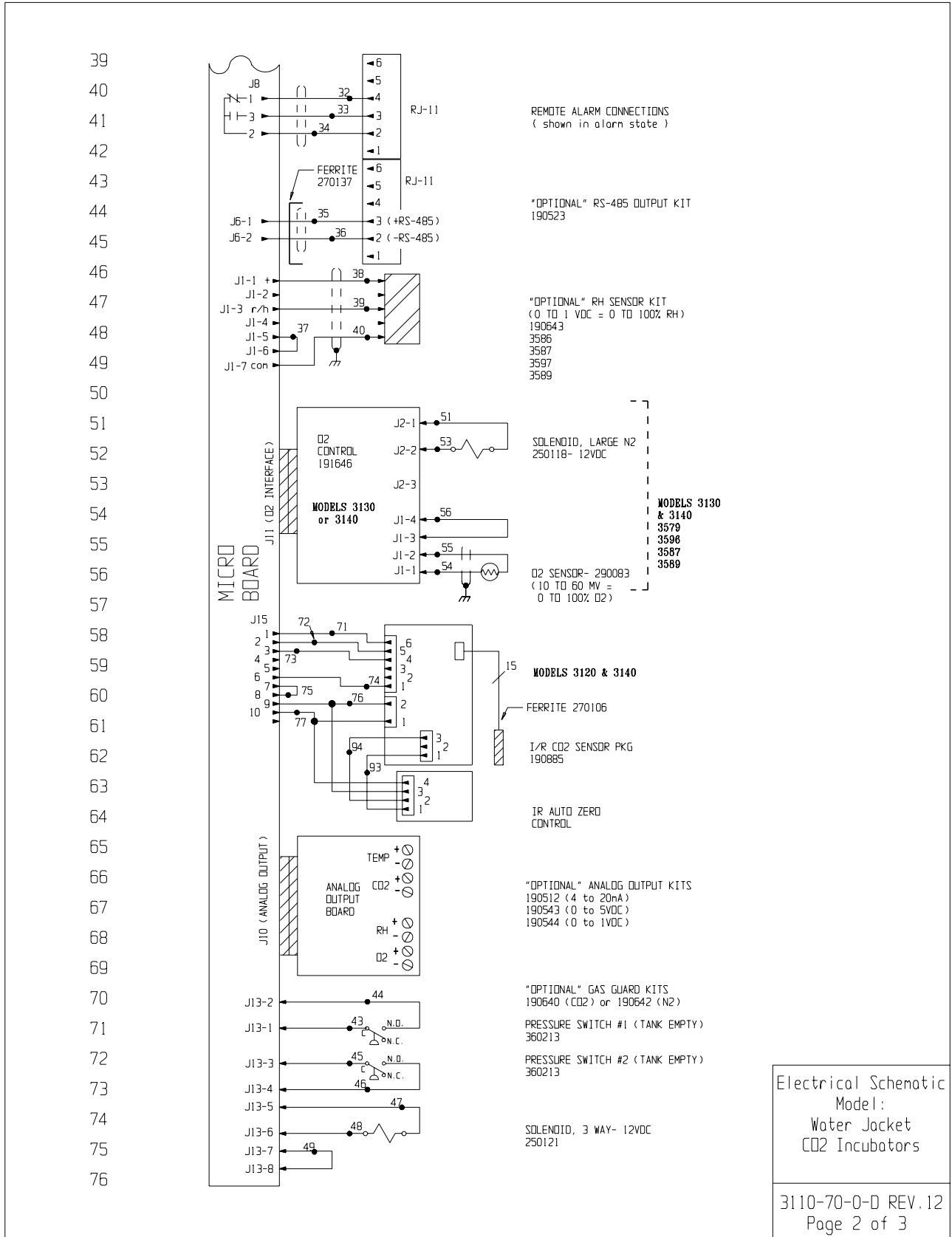

77
78
79
80
81
82
83
84
85
86
87
88
89
90
91
92
93
94
95
96
97
98
99
100
101
102
103
104
105
106
107

WIRE REFERENCE CHART								
NO.	GA.	COLOR	NO.	GA.	COLOR	NO.	GA.	COLOR
1	16	BROWN	26	22	YELLOW	52	N/U	
2	16	BLUE	27	22	YELLOW	53	20	PURPLE
3	16	GRN/YEL	28	22	GREEN	54	22/2	RED
3B	16	GREEN	29	22	GRAY	55	22/2	BLACK
4	18	BLACK	30	22	PURPLE	56	22	BLACK
5	18	BLACK	31	22	ORANGE	57		
6	18	WHITE	32	22/3	BLACK		N/U	
7	N/U		33	22/3	RED	66		
8	18	BROWN	34	22/3	WHITE	67	18	RED
9	18	BLUE	35	22/2	RED	68	18	ORANGE
10	18	YELLOW	36	22/2	BLACK	69	N/U	
11	18	YELLOW	37	22	BLACK	70	N/U	
12	18	BLACK	38	22/3	BLACK	71	22	BLUE
13	18	GREEN	39	22/3	RED	72	22	ORANGE
14	18	BLUE	40	22/3	GREEN	73	22	YELLOW
15	18	ORANGE	41	18	RED	74	22	BROWN
16	18	RED	42	18	BLACK	75	22	BLACK
17	18	GREEN	43	20	RED	76	22	RED
18	18	ORANGE	44	20	RED	77	22	GREEN
19	18	GREEN	45	20	BLUE	78		
20	18	ORANGE	46	20	BLUE		24/15	L/R CABLE
21	22	BROWN	47	20	ORANGE	91		
22	22	BLUE	48	20	ORANGE	92	22	BLACK
23	22	BLUE	49	20	BLACK	93	22	BROWN
24	22	RED	50	N/U		94	22	WHITE
25	22	RED	51	20	YELLOW			

N/U= Not Used

SENSOR REFERENCE VALUES

CO2 (290090) DIFFERENCE VOLTAGE OF 3-6MV/2CO2
J4-9 & J4-10 TO J4-9 & J4-11

RH (190643) J1-7 & J1-1 = 12VDC
J1-7 & J1-3 = 10MV/2RH

O2 (290083) J6-1 & J6-2 = 12MV @ 21XO2

MODEL	DESCRIPTION
3110	WATER JACKET INCUBATOR - TC CO2
3120	WATER JACKET INCUBATOR - IR CO2
3130	WATER JACKET INCUBATOR - TC O2
3140	WATER JACKET INCUBATOR - IR O2
3578	WATER JACKET INCUBATOR - TC CO2 (FISHER NAPCO)
3579	WATER JACKET INCUBATOR - IR CO2 (FISHER NAPCO)
3595	WATER JACKET INCUBATOR - TC O2 (FISHER NAPCO)
3596	WATER JACKET INCUBATOR - IR O2 (FISHER NAPCO)
3586	WATER JACKET INCUBATOR - TC CO2 RH DISPLAY (FISHER NAPCO)
3587	WATER JACKET INCUBATOR - IR CO2 RH DISPLAY (FISHER NAPCO)
3597	WATER JACKET INCUBATOR - TC O2 RH DISPLAY (FISHER NAPCO)
3589	WATER JACKET INCUBATOR - IR O2 RH DISPLAY (FISHER NAPCO)
3428	WATER JACKET INCUBATOR - TC CO2 - 115 VOLT
3422	WATER JACKET INCUBATOR - IR CO2 - 115 VOLT
3424	WATER JACKET INCUBATOR - TC O2 - 115 VOLT
3426	WATER JACKET INCUBATOR - IR O2 - 115 VOLT

NOTES:	
\oplus Denotes Terminal Strip Connection	Parts List Reference Number
Last Relay Number	<input type="radio"/> Assembly
Last Terminal Number	<input type="radio"/> Panel
Last Wire Number	<input type="radio"/> Refrigeration
\rightarrow Denotes Pin & Socket Connection	<input type="checkbox"/> Wiring

THIS DOCUMENT CONTAINS PROPRIETARY INFORMATION AND SUCH INFORMATION IS NOT TO BE DISCLOSED TO OTHERS FOR ANY PURPOSE NOR USED FOR MANUFACTURING PURPOSES WITHOUT WRITTEN PERMISSION FROM THERMO ELECTRON



12	IN-3759	01-12-07	GJG	GJG	CCS	ADDED NEW MODEL NUMBERS (8000 SERIES)
11	IN-3306	06-13-06	GJG	GJG	MSB	ADDED NEW MODEL NUMBERS (FISHER NAPCO)
10	IN-3124	08-04-03	JNL	KDG	MSB	CHG. 290137 TEMP. PROBE TO 290184
9	IN-3049	10-01-02	GJG	GJG	MSB	REVISED MOTOR PART NUMBER
8	SI-7897	06-05-00	GJG	GJG	MSB	UPDATE PER CHANGES FROM "UL" TESTING
7	SI-7897	05-01-00	GJG	GJG	DNF	UPDATE PER LEVEL 5 P.L. CHANGES
REV	ECLN NO.	DATE	BY	CAD/APPD	DESCRIPTION OF REVISION	
		Mar 2000	DWN	GJG	CAD GJG APPD DNF SCALE NA	

CUSTOMER MODELS (SEE LIST ABOVE)		
JOB TITLE MODULAR WATER JACKET INCUBATOR 115 VOLT (COM.)		
DWG TITLE ELECTRICAL SCHEMATIC		
LOCATION	JOB NUMBER	DRAWING NUMBER
INCUBATR		3110-70-0-D

Electrical Schematic
Model:
Water Jacket
CO2 Incubators

3110-70-0-D REV.12
Page 3 of 3

Section 9
Section title

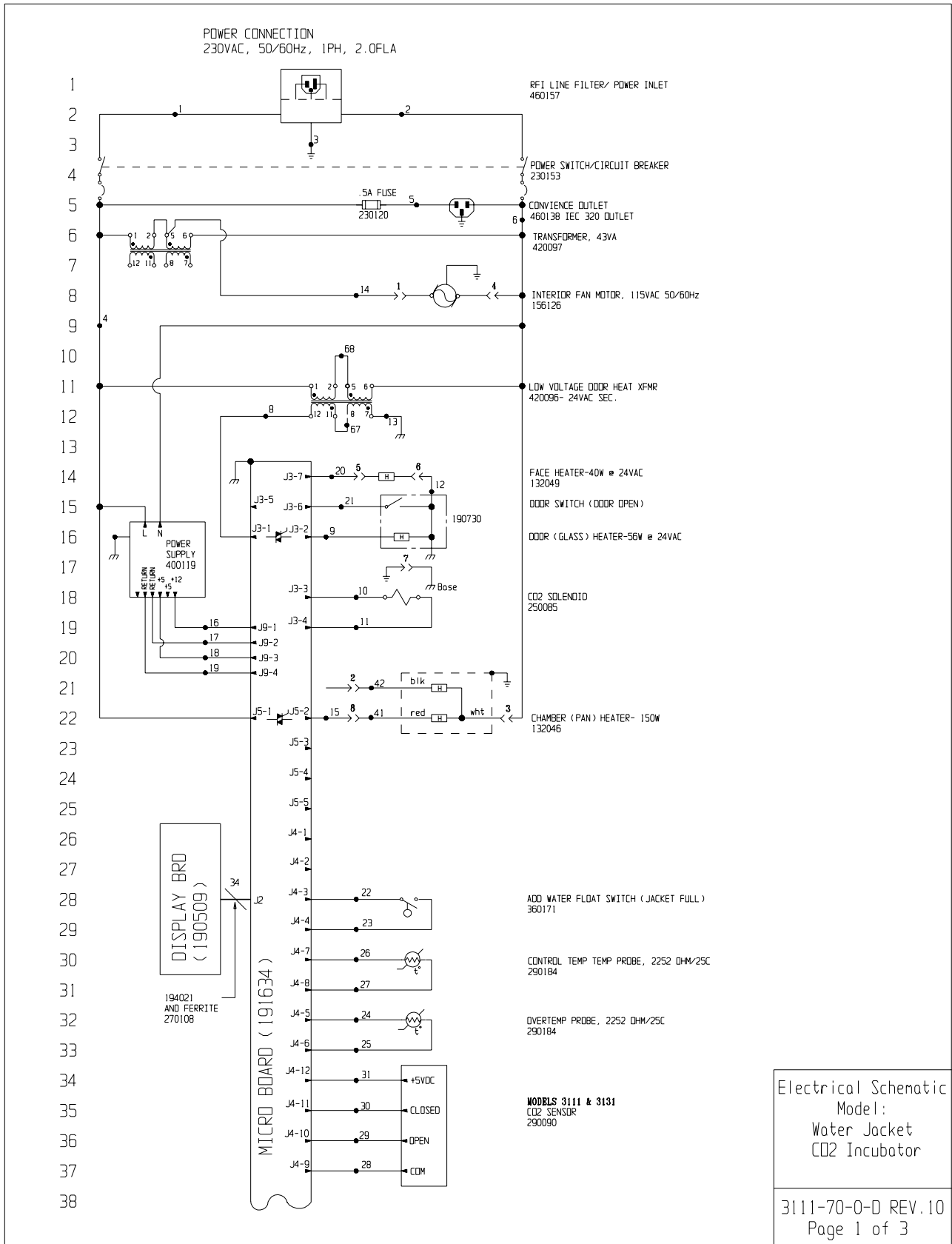

39
40
41
42
43
44
45
46
47
48
49
50
51
52
53
54
55
56
57
58
59
60
61
62
63
64
65
66
67
68
69
70
71
72
73
74
75
76

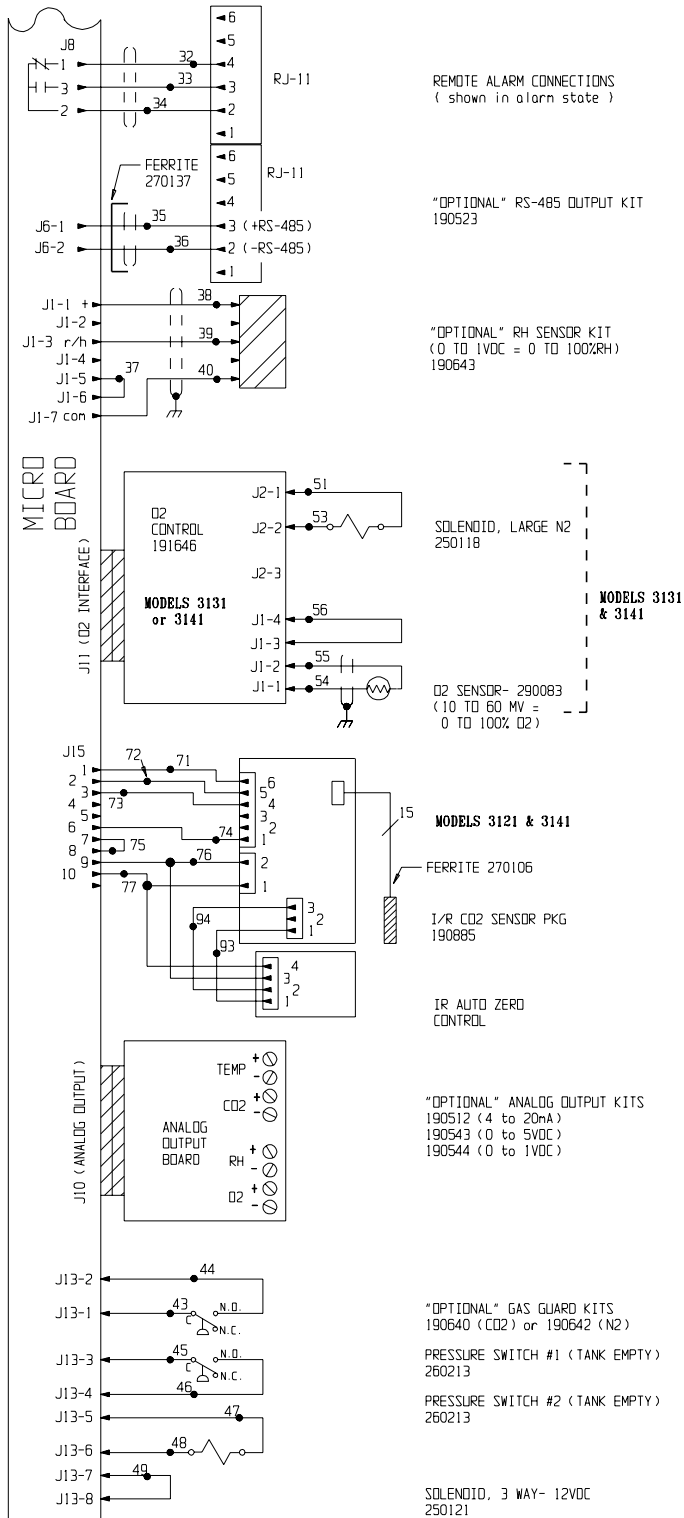

Electrical Schematic
Model:
Water Jacket
CO2 Incubator

3111-70-0-D REV.10
Page 2 of 3

Section 9
Section title

77
78
79
80
81
82
83
84
85
86
87
88
89
90
91
92
93
94
95
96
97
98
99
100
101
102
103
104
105
106
107

WIRE REFERENCE CHART								
NO.	GA.	COLOR	NO.	GA.	COLOR	NO.	GA.	COLOR
1	16	BROWN	26	22	YELLOW	52	N/U	
2	16	BLUE	27	22	YELLOW	53	20	PURPLE
3	16	GRN/YEL	28	22	GREEN	54	22/2	RED
3B	16	GREEN	29	22	GRAY	55	22/2	BLACK
4	18	BLACK	30	22	PURPLE	56	22	BLACK
5	18	BLACK	31	22	ORANGE	57		
6	18	WHITE	32	22/3	BLACK		N/U	
7	N/U		33	22/3	RED	66		
8	18	BROWN	34	22/3	WHITE	67	18	RED
9	18	BLUE	35	22/2	RED	68	18	ORANGE
10	18	YELLOW	36	22/2	BLACK	69	N/U	
11	18	YELLOW	37	22	BLACK	70	22	BLACK
12	18	BLACK	38	22/3	BLACK	71	22	BLUE
13	18	GREEN	39	22/3	RED	72	22	ORANGE
14	18	BLUE	40	22/3	GREEN	73	22	YELLOW
15	18	ORANGE	41	18	RED	74	22	BROWN
16	18	RED	42	18	BLACK	75	22	BLACK
17	18	GREEN	43	20	RED	76	22	RED
18	18	ORANGE	44	20	RED	77	22	GREEN
19	18	GREEN	45	20	BLUE	78		1/R
20	18	ORANGE	46	20	BLUE		24/15	CABLE
21	22	BROWN	47	20	ORANGE	91		
22	22	BLUE	48	20	ORANGE	92	22	BLACK
23	22	BLUE	49	20	BLACK	93	22	BROWN
24	22	RED	50	N/U		94	22	WHITE
25	22	RED	51	20	YELLOW			

N/U= Not Used

SENSOR REFERENCE VALUES

CO2 (290090) DIFFERENCE VOLTAGE OF 3-6MV/±CO2
J4-9 & J4-10 TO J4-9 & J4-11

RH (190643) J1-7 & J1-1 = 12VDC
J1-7 & J1-3 = 10MV/±RH

O2 (290083) J6-1 & J6-2 = 12MV ± 21%O2

MODEL	DESCRIPTION
3110	WATER JACKET INCUBATOR - TC CO2
3120	WATER JACKET INCUBATOR - IR CO2
3130	WATER JACKET INCUBATOR - TC O2
3140	WATER JACKET INCUBATOR - IR O2
3429	WATER JACKET INCUBATOR - TC CO2 (THERMO 8000)
3423	WATER JACKET INCUBATOR - IR CO2 (THERMO 8000)
3425	WATER JACKET INCUBATOR - TC O2 (THERMO 8000)
3427	WATER JACKET INCUBATOR - IR O2

NOTES:	
⊕ Denotes Terminal Strip Connection	Parts List Reference Number
○ Lost Relay Number	○ Assembly
○ Lost Terminal Number	◇ Panel
○ Lost Wire Number	○ Refrigeration
→ >— Denotes Pin & Socket Connection	□ Wiring

THIS DOCUMENT CONTAINS PROPRIETARY INFORMATION AND SUCH INFORMATION IS NOT TO BE DISCLOSED TO OTHERS FOR ANY PURPOSE NOR USED FOR MANUFACTURING PURPOSES WITHOUT WRITTEN PERMISSION FROM THERMO ELECTRON.



10	IN-3759	01-12-07	G.JG	CCS	ADDED SERIES 8000 INCUBATOR REFERENCE
9	IN-3124	08-04-03	JUNL	KDC	MSB CHG. 290137 TEMP. PROBE TO 290184
8	IN-3049	10-01-02	G.JG	MSB	REVISED MOTOR PART NUMBER
7	SI-7897	06-05-00	G.JG	MSB	UPDATE PER CHANGES FROM "UL" TESTING
6	SI-7897	05-01-00	G.JG	DNF	UPDATE PER LEVEL 5 P.L. CHANGES
REV	ECN NO.	DATE	BY	CAD/APPD	DESCRIPTION OF REVISION
	DATE 9-24-85		DWN G.JG	CAD G.JG	APPD DNF SCALE
CUSTOMER: MODELS 3111, 3121, 3131 & 3141					
JOB TITLE MODULAR WATER JACKET INCUBATOR 230 VOLT (EXPORT)					
DWG TITLE ELECTRICAL SCHEMATIC					
LOCATION		JOB NUMBER		DRAWING NUMBER	
INCUBATR				3111-70-0-D	

Electrical Schematic
Model:
Water Jacket
CO2 Incubator

3111-70-0-D REV.10
Page 3 of 3

THERMO FISHER SCIENTIFIC STANDARD PRODUCT WARRANTY

The Warranty Period starts two weeks from the date your equipment is shipped from our facility. This allows for shipping time so the warranty will go into effect at approximately the same time your equipment is delivered. The warranty protection extends to any subsequent owner during the first year warranty period.

During the first year, component parts proven to be non-conforming in materials or workmanship will be repaired or replaced at Thermo's expense, labor included. Installation and calibration are not covered by this warranty agreement. The Technical Services Department must be contacted for warranty determination and direction prior to performance of any repairs. Expendable items, glass, filters and gaskets are excluded from this warranty.

Replacement or repair of components parts or equipment under this warranty shall not extend the warranty to either the equipment or to the component part beyond the original warranty period. The Technical Services Department must give prior approval for return of any components or equipment. At Thermo's option, all non-conforming parts must be returned to Thermo Electron Corporation postage paid and replacement parts are shipped FOB destination.

THIS WARRANTY IS EXCLUSIVE AND IN LIEU OF ALL OTHER WARRANTIES, WHETHER WRITTEN, ORAL OR IMPLIED. NO WARRANTIES OF MERCHANTABILITY OR FITNESS FOR A PARTICULAR PURPOSE SHALL APPLY. Thermo shall not be liable for any indirect or consequential damages including, without limitation, damages relating to lost profits or loss of products.

Your local Thermo Sales Office is ready to help with comprehensive site preparation information before your equipment arrives. Printed instruction manuals carefully detail equipment installation, operation and preventive maintenance.

If equipment service is required, please call your Technical Services Department at 1-888-213-1790 (USA and Canada) or 1-740-373-4763. We're ready to answer your questions on equipment warranty, operation, maintenance, service and special application. Outside the USA, contact your local distributor for warranty information.



THERMO FISHER SCIENTIFIC INTERNATIONAL DEALER WARRANTY

The Warranty Period starts two months from the date your equipment is shipped from our facility. This allows for shipping time so the warranty will go into effect at approximately the same time your equipment is delivered. The warranty protection extends to any subsequent owner during the first year warranty period. Dealers who stock our equipment are allowed an additional six months for delivery and installation, provided the warranty card is completed and returned to the Technical Services Department.

During the first year, component parts proven to be non-conforming in materials or workmanship will be repaired or replaced at Thermo's expense, labor excluded. Installation and calibration are not covered by this warranty agreement. The Technical Services Department must be contacted for warranty determination and direction prior to performance of any repairs. Expendable items, glass, filters, reagents, tubing, and gaskets are excluded from this warranty.

Replacement or repair of components parts or equipment under this warranty shall not extend the warranty to either the equipment or to the component part beyond the original warranty period. The Technical Services Department must give prior approval for return of any components or equipment. At Thermo's option, all non-conforming parts must be returned to Thermo postage paid and replacement parts are shipped FOB destination.

THIS WARRANTY IS EXCLUSIVE AND IN LIEU OF ALL OTHER WARRANTIES, WHETHER WRITTEN, ORAL OR IMPLIED. NO WARRANTIES OF MERCHANTABILITY OR FITNESS FOR A PARTICULAR PURPOSE SHALL APPLY. Thermo shall not be liable for any indirect or consequential damages including, without limitation, damages relating to lost profits or loss of products.

Your local Thermo Sales Office is ready to help with comprehensive site preparation information before your equipment arrives. Printed instruction manuals carefully detail equipment installation, operation and preventive maintenance.

If equipment service is required, please call your Technical Services Department at 1-888-213-1790 (USA or Canada), or 1-740-373-4763. We're ready to answer your questions on equipment warranty, operation, maintenance, service and special application. Outside the USA, contact your local distributor for warranty information.



picofast "Snap Lock" Connector Instructions

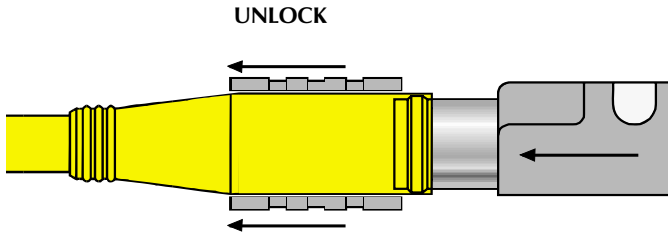

With TURCK's patented Locking Sleeve pulled back, any **picofast** sensor slides on without any difficulty.

After sensor is connected, push Locking Sleeve forward to create a watertight connection. It's a snap!

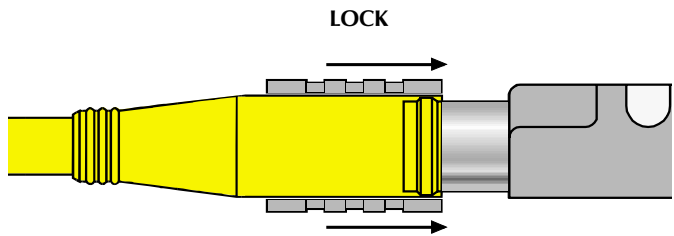

Installation Instructions

To Attach:

1. Be sure black locking sleeve is pulled back.

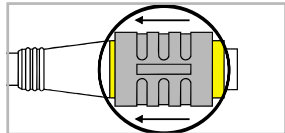

2. Line up pins and push connector onto plug. You will feel a "snap." Do not twist.

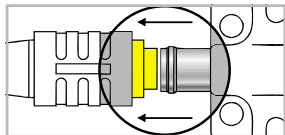

3. Push locking sleeve forward on connector until it is flush with the front of the connector.

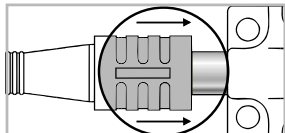

4. If sleeve is difficult to slide on a new connector, "exercise" it a few times. Do not use tools.

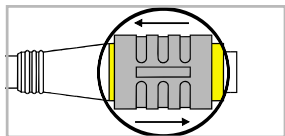

To Detach:

1. Do not twist.

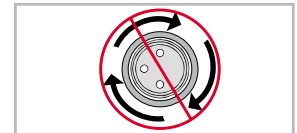

2. Pull locking sleeve back to "unlocked" position.

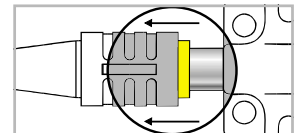

3. Pull connector straight off.

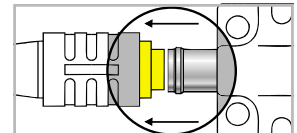

4. Leave locking sleeve in unlocked position.

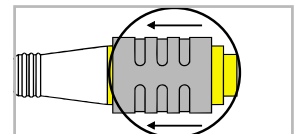

Declaration of Conformity

Manufacturer's Name: Thermo Fisher Scientific (Asheville) LLC
Manufacturer's Address: 401 Millcreek Road
Marietta, Ohio 45750
U.S.A.
Product Description: Thermo Laboratory Incubator
Product Designations: 3422
Year of Initial Marking (CE): 2007
Affected Serial Numbers: Release 1
(Release Level [REL#] shown on serial tag)

This product conforms to the following European Union Directive(s):

EMC: 89/336/EEC
LVD: 73/23/EEC

This product conforms to the following Harmonized, International and National Standards:

EMC:	LVD:
EN 61326-1:1997 (Class A)	EN 61010-1:1993
EN 50081-1	Amendments 1 and 2
EN 50082-1	CSA C22.2 No. 1010.1
EN 50011-1:97	UL 61010-1
	UL 61010-2-010

Richard L. Miller, CQE
Regulatory Compliance Manager

ThermoFisher
S C I E N T I F I C

25 January 2007

Declaration of Conformity

Manufacturer's Name: Thermo Fisher Scientific (Asheville) LLC
Manufacturer's Address: 401 Millcreek Road
Marietta, Ohio 45750
U.S.A.
Product Description: Thermo Laboratory Incubator
Product Designations: 3423
Year of Initial Marking (CE): 2007
Affected Serial Numbers: Release 1
(Release Level [REL#] shown on serial tag)

This product conforms to the following European Union Directive(s):

EMC: 89/336/EEC
LVD: 73/23/EEC

This product conforms to the following Harmonized, International and National Standards:

EMC:	LVD:
EN 61326-1:1997 (Class A)	EN 61010-1:1993
EN 50081-1	Amendments 1 and 2
EN 50082-1	CSA C22.2 No. 1010.1
EN 50011-1:97	UL 61010-1
	UL 61010-2-010

Richard L. Miller, CQE
Regulatory Compliance Manager

ThermoFisher
S C I E N T I F I C

25 January 2007

Declaration of Conformity

Manufacturer's Name: Thermo Fisher Scientific (Asheville) LLC
Manufacturer's Address: 401 Millcreek Road
Marietta, Ohio 45750
U.S.A.
Product Description: Thermo Laboratory Incubator
Product Designations: 3424
Year of Initial Marking (CE): 2007
Affected Serial Numbers: Release 1
(Release Level [REL#] shown on serial tag)

This product conforms to the following European Union Directive(s):

EMC: 89/336/EEC
LVD: 73/23/EEC

This product conforms to the following Harmonized, International and National Standards:

EMC:	LVD:
EN 61326-1:1997 (Class A)	EN 61010-1:1993
EN 50081-1	Amendments 1 and 2
EN 50082-1	CSA C22.2 No. 1010.1
EN 50011-1:97	UL 61010-1
	UL 61010-2-010

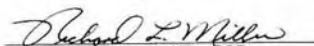
Richard L. Miller, CQE
Regulatory Compliance Manager

ThermoFisher
S C I E N T I F I C

25 January 2007

Declaration of Conformity

Manufacturer's Name: Thermo Fisher Scientific (Asheville) LLC
Manufacturer's Address: 401 Millcreek Road
Marietta, Ohio 45750
U.S.A.
Product Description: Thermo Laboratory Incubator
Product Designations: 3425
Year of Initial Marking (CE): 2007
Affected Serial Numbers: Release 1
(Release Level [REL#] shown on serial tag)

This product conforms to the following European Union Directive(s):

EMC: 89/336/EEC
LVD: 73/23/EEC

This product conforms to the following Harmonized, International and National Standards:

EMC:	LVD:
EN 61326-1:1997 (Class A)	EN 61010-1:1993
EN 50081-1	Amendments 1 and 2
EN 50082-1	CSA C22.2 No. 1010.1
EN 50011-1:97	UL 61010-1
	UL 61010-2-010

Richard L. Miller, CQE
Regulatory Compliance Manager

ThermoFisher
S C I E N T I F I C

25 January 2007

Declaration of Conformity

Manufacturer's Name: Thermo Fisher Scientific (Asheville) LLC
Manufacturer's Address: 401 Millcreek Road
Marietta, Ohio 45750
U.S.A.
Product Description: Thermo Laboratory Incubator
Product Designations: 3426
Year of Initial Marking (CE): 2007
Affected Serial Numbers: Release 1
(Release Level [REL#] shown on serial tag)

This product conforms to the following European Union Directive(s):

EMC: 89/336/EEC
LVD: 73/23/EEC

This product conforms to the following Harmonized, International and National Standards:

EMC:	LVD:
EN 61326-1:1997 (Class A)	EN 61010-1:1993
EN 50081-1	Amendments 1 and 2
EN 50082-1	CSA C22.2 No. 1010.1
EN 50011-1:97	UL 61010-1
	UL 61010-2-010

Richard L. Miller, CQE
Regulatory Compliance Manager

ThermoFisher
SCIENTIFIC

25 January 2007

Declaration of Conformity

Manufacturer's Name: Thermo Fisher Scientific (Asheville) LLC
Manufacturer's Address: 401 Millcreek Road
Marietta, Ohio 45750
U.S.A.
Product Description: Thermo Laboratory Incubator
Product Designations: 3427
Year of Initial Marking (CE): 2007
Affected Serial Numbers: Release 1
(Release Level [REL#] shown on serial tag)

This product conforms to the following European Union Directive(s):

EMC: 89/336/EEC
LVD: 73/23/EEC

This product conforms to the following Harmonized, International and National Standards:

EMC:	LVD:
EN 61326-1:1997 (Class A)	EN 61010-1:1993
EN 50081-1	Amendments 1 and 2
EN 50082-1	CSA C22.2 No. 1010.1
EN 50011-1:97	UL 61010-1
	UL 61010-2-010

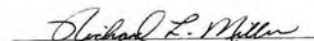
Richard L. Miller, CQE
Regulatory Compliance Manager

ThermoFisher
SCIENTIFIC

25 January 2007

Declaration of Conformity

Manufacturer's Name: Thermo Fisher Scientific (Asheville) LLC
Manufacturer's Address: 401 Millcreek Road
Marietta, Ohio 45750
U.S.A.
Product Description: Thermo Laboratory Incubator
Product Designations: 3429
Year of Initial Marking (CE): 2007
Affected Serial Numbers: Release 1
(Release Level [REL#] shown on serial tag)

This product conforms to the following European Union Directive(s):

EMC: 89/336/EEC
LVD: 73/23/EEC

This product conforms to the following Harmonized, International and National Standards:

EMC:	LVD:
EN 61326-1:1997 (Class A)	EN 61010-1:1993
EN 50081-1	Amendments 1 and 2
EN 50082-1	CSA C22.2 No. 1010.1
EN 50011-1:97	UL 61010-1
	UL 61010-2-010

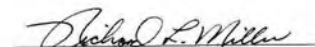
Richard L. Miller, CQE
Regulatory Compliance Manager

ThermoFisher
SCIENTIFIC

25 January 2007

