

HOTSPOT



ENERGY

Air Conditioner Water Heater - A Product of HotSpot Energy LLC

PLEASE READ THIS BEFORE YOU INSTALL THE UNIT

1. This air conditioner must be installed and/or repaired by a qualified technician. If you perform part of the installation yourself, you **MUST** have a qualified HVAC technician commission the unit. Commissioning includes inspecting the installation work and making all final electrical and refrigeration connections, evacuating the unit with a vacuum pump, releasing the R410a pre-charged refrigerant into the system, and starting up and testing the unit.

If you have used a HotSpot provided 25 ft. line-set extension or have used a custom-made line-set longer than the 25 ft. the technician will need to add oil and refrigerant per the installation manual instructions.

YOU CANNOT COMMISSION THE UNIT YOURSELF.

2. The air conditioning unit must be grounded properly.

3. This unit contains a heat recovery water heating circuit. Make sure to leave the pump switch (located on the outdoor unit) in OFF position during the installation process until the water supply is connected and turned on. Do not allow the pump to operate without water flow.

FAILURE TO OBSERVE THE ABOVE MAY DAMAGE THE EQUIPMENT AND VOID YOUR WARRANTY.

Please read the **SAFETY AND OPERATING INSTRUCTIONS** carefully before operating the unit. Please respect the safety precautions when using your air conditioner to prevent fire, shock hazard, personal injury or death.

SAFETY PRECAUTIONS

INSTALLATION AND OPERATION PRECAUTIONS

Do not attempt to perform any work yourself that involves opening an equipment cabinet or that involves any refrigerant or electrical connections.

You should only do part of the installation if you are qualified to do so. This may include mounting the outdoor unit on a pad and mounting the indoor unit, laying out and mounting the line-set, drain line, but not connecting the line-set to the indoor or outdoor units. You may also choose to lay out and run the electrical line from your power source to the system but do not connect the wiring at either end. You may also choose to run the water lines and connect them to the tank and to the unit if you are qualified to do so, if so please follow the instructions that are provided and make sure you perform the work in compliance with IAPMO and local plumbing codes.

If you do part of the installation improperly, this may cause water leakage, water damage, refrigerant leakage, damage to the unit, electric shock, fire, injury or death. The unit should be installed by a qualified technician.

ONLY A LICENSED HVAC TECHNICIAN CAN COMMISSION THE UNIT, AFTER FOLLOWING NORMAL INDUSTRY STANDARD PROCEDURES AND MAKING ALL ELECTRICAL AND REFRIGERANT CONNECTIONS, EVACUATING AND PROPERLY CHARGING THE SYSTEM. COMMISSIONING MUST BE PERFORMED ACCORDING TO ASHREA/AHRI STANDARD PROCEDURES AND LOCAL CODES.

Please use a proper ground. Improper grounding could cause electric shock, fire or equipment damage. Do not place the ground line near water or gas pipes, electric or telephone lines.

Do not install the unit in a place where there could be a gas leak. The unit may catch fire or cause an explosion if flammable gas leaks around it. This unit is not rated for operation in a hazardous environment.

Please ensure smooth flow of water when installing the drain hose. If the drain line becomes kinked or blocked you will likely suffer water damage. The indoor unit should be installed at least 7 ft. high from the floor.

If the fuse on the PCB board is blown, please have it changed only by a Qualified technician.

Do not operate with wet hands.

Avoid staying directly in front of operating unit.

Do not insert foreign objects into the unit.

Always have the unit repaired by a professional technician.

Danger of electric shock or fire if used improperly.

Do not use if the power cord is damaged, it could cause an electric shock or fire.

Do not allow children to operate the air conditioner.

Never sit on the unit.

If you notice an abnormality (burnt smell, etc) please shut the power off from the Breaker.

The unit should not be used for any other purpose.

Avoid spilling liquids on the unit.

Do not place the air conditioner close to a heat source, it could cause a deformation or color fading.

Do not block the air intake and outlet vents.

Do not let the air conditioner function at maximum power for an extended period of time (close all doors and windows).

Do not operate without the air filter installed or when the front intake grill has been removed.

Do not place anything on the unit.

Always turn the power off before cleaning the air conditioner to avoid any possible accidents.

Please ensure proper ventilation when using the air conditioner.

CONTENTS

To Consumers

Safety Precautions

Part 1 Operation Instructions

Part names and functions

1-1 Indoor unit

1-2 Outdoor unit

1-3 Remote control

Part 2 Preparation before operation

2-1 Preparations of the remote controller

Part 3 Operation Settings

3-1 Cooling – Heating – Dehumidification

3-2 Timer operation

3-3 Air flow adjustment

3-4 Fan

3-5 Automatic Mode

3-6 Emergency switch

3-8 High Power

3-9 Switch from C to F

Part 4 System Maintenance

Part 5 Water Heating Circuit

Part 6 Troubleshooting Cooling & Heating

Main Specifications

PART I OPERATION INSTRUCTIONS

1. Part name and functions 1-1 Indoor Unit

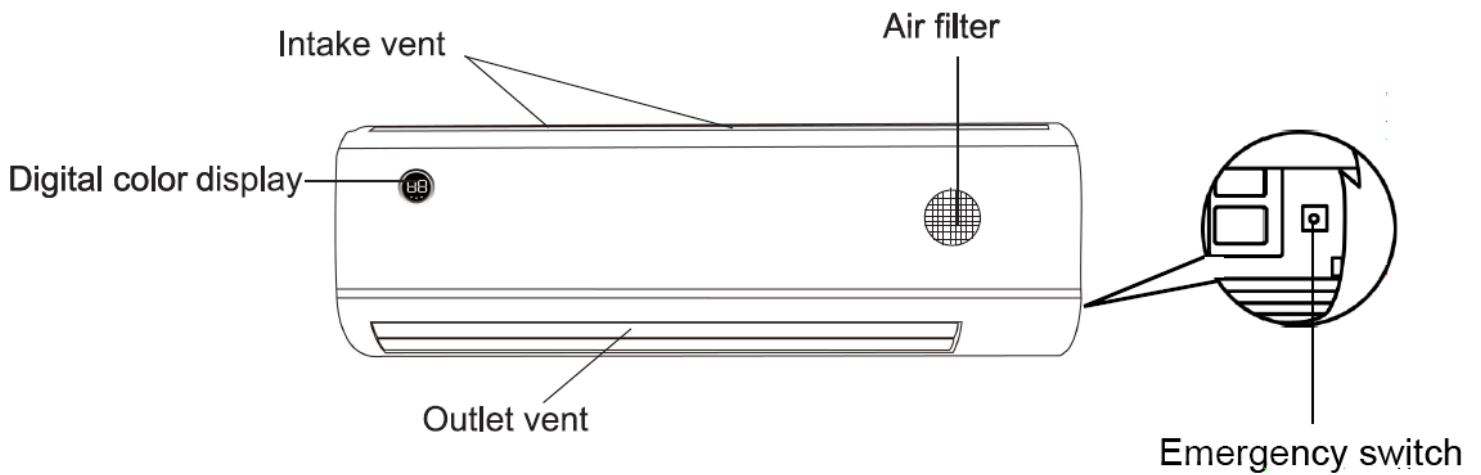

COLOR DISPLAY

Green light is on: Unit is on.

Green light is off: Unit is off.

Yellow light on: Air conditioner is set on timer.

Red light is flashing: Air conditioner is abnormal, please consult a technician.

Press the "LOCK" button once, color display goes off. press it again, color display turns back on.



1-2 Outdoor Unit

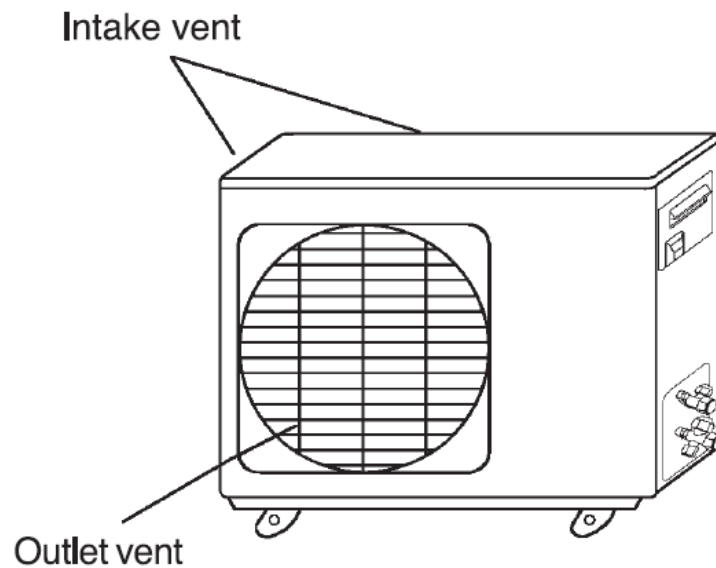





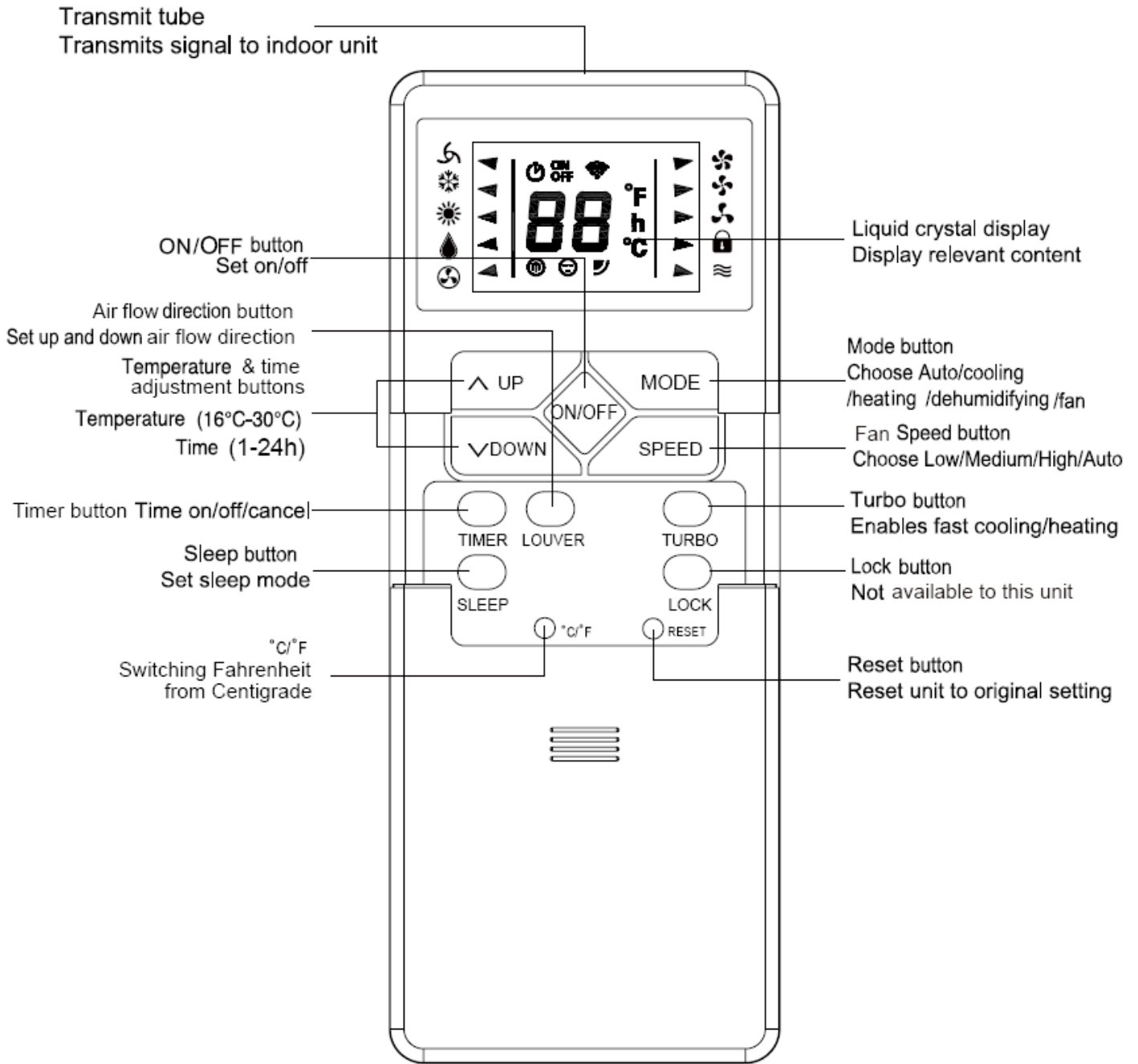





NOTE: The diagram above is of a standard exterior unit and may differ from your unit.

1-3 REMOTE CONTROL



1-3

INSTRUCTIONS FOR REMOTE CONTROL

- 1. Mode display 
- 2. Temperature setting 
- 3. Air flow direction display 
- 4. Fan speed display 
- 5. Time setting display 
- 6. Turbo display 
- 7. Sleep timer 
- 8. Lock display 
- 9. Signal transmitting display 
- 10. Operational display 

2 PREPARATION BEFORE OPERATION

2-1 PREPARATION OF THE REMOTE CONTROL

1. Operation of the remote controller

Aim the remote towards the Indoor unit.

There should not be any obstructions between the remote and the indoor unit.

Avoid direct sun shine and keep away from heat source.

Keep the remote in a dry and clean place.

Attention

Please replace only with two new AAA size 1.5 V batteries.

Remove the batteries if unit is not used for a long period of time.

Never mix old and new batteries.

If after changing the batteries the remote do not work, please press the reset button.

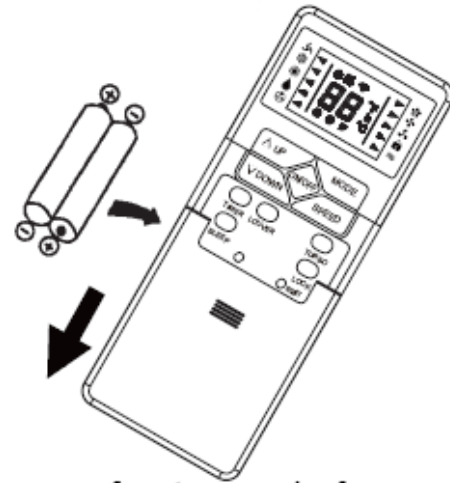

Remove front cover before changing the batteries

3 OPERATION SETTINGS

3-1 COOLING, HEATING AND DE-HUMIDIFYING OPERATION

1. Press **ON/OFF** button the Air Conditioner will turn on.
2. Press **MODE** button to choose cooling, heating or de-humidifying mode.
3. Press up and down button to adjust the temperature between 16 to 30. Press the up or down button once, the temperature changes by one degree.
4. Press **SPEED** button , the fan speed will be regulated(see Air Flow adjustment).

NOTE; Auto fan speed cannot be chosen in de-humidify mode.

1. Press **LOUVER** button, the louver will be regulated(see Air Flow adjustment).
2. Press **ON/OFF** button again, the Air Conditioner will stop operating.

Attention;

In the Heating mode if the ambient temperature is very low, the following condition may appear;

- The indoor unit stops to avoid blowing cold air.
- There may be cracking noise from the plastic parts
- The blowing air may not be warm enough
- The air conditioner will defrost automatically
- There may be steam coming out of the outdoor unit.

3-2 TIMER OPERATION

Press **TIMER** button ON or OFF: displays in the LCD panel and the Air conditioner will auto start or stop according to the pre set times.

1. Press **TIMER** button ON, the time on the LCD display changes to temperature.
Press UP and DOWN to set the time of auto start, five seconds later time will be confirmed and the number changes back to temperature.
2. Press **TIMER** button OFF, the temperature on the LCD display changes to time.
Press UP and DOWN to set the time of auto stop, five seconds later time will be confirmed and the number change back to temperature.
3. Press **TIMER** button, there is no ON or OFF, the auto start or auto stop is cancelled.

NOTE;

- 1.The unit of time is HOUR.
- 2.The time range is 1-24 hours.

3-3 AIR FLOW ADJUSTMENT

1. Fan speed

Press **SPEED** button to adjust fan speed as follows;

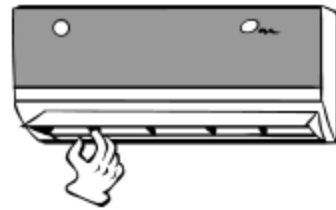

2. Horizontal direction

For horizontal direction of Air flow, set blades left or right manually.

3. Vertical direction

Press **LOUVER** once, the Louver will swing up and down. Press it again and it stops at your desired position.

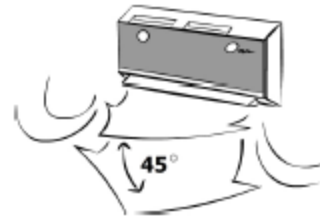

3-4 FAN

1. Press **ON/OFF** button, the Air conditioner starts operating.
2. Press **MODE** button, choose Fan mode.
3. Press **SPEED** button, choose your desired Fan speed.
4. Press **ON/OFF** button, the Air conditioner stops operating.

NOTE:

When the unit is in the FAN MODE, Green light stays on, the temperature cannot be changed, the Auto Fan speed cannot be chosen and "F" displays in LCD.



3-5 AUTOMATIC MODE

When the unit is in Auto Mode the Green light stays on.

- The temperature, Fan speed and Air flow direction is preset

1. Press **ON/OFF** button to turn the unit on.
2. Press **MODE** button and choose Automatic.
3. Press **UP/DOWN** to regulate preset temperature.
4. Press **SPEED**, the Air flow speed can be regulated.
5. Press **LOUVER**, the Air flow direction can be regulated.
6. Press **ON/OFF**, unit stops operation.



NOTE:

In AUTOMATIC mode, the unit cools, heats or fan according to difference in temperatures.

3-6 EMERGENCY SWITCH

Emergency switch can be used when the remote controller does not work or it is lost.

By pressing this button (also called the reset switch) the unit re starts, with the temperature set at 24 degrees C. The mode the unit starts at, cooling, heating or just fan, depends on the temperature between the indoor room temperature and the set temperature after re-start.



3-7 HIGH POWER

Press **TURBO** button in cooling or heating mode, then this signal  displays on LCD.

Press **TURBO** button again to cancel the high power function. During high power function the unit operates more efficiently than normal.

NOTE:

1. High Power function is generally used only when just starting up the unit.
2. The indoor unit runs at highest fan speed during this function.

The high power function stops automatically after 15 minutes. Then the unit runs with the minimum frequency for 5 minutes, then it runs in the pre-set mode and the  symbol automatically disappears.

3. The noise will be higher than normal in the High Power function



3-8 SLEEP MODE

For better comfort during sleeping, the temperature will be increased in cooling mode and decreased in the heating mode during this function.

Press **SLEEP** button to start the sleep function and this symbol  displays on the LCD. Press it again to cancel this function.



3-9 SWITCHING FROM C TO F

Press **°C/°F** button to switch the display from Celsius to Fahrenheit.

4- SYSTEM MAINTENANCE

ATTENTION; ALWAYS TURN THE UNIT OFF BEFORE CLEANING

Cleaning of the remote control	Clean the intake vent grill
Clean with a damp cloth	Clean with a damp cloth. If necessary use a gentle soap. .

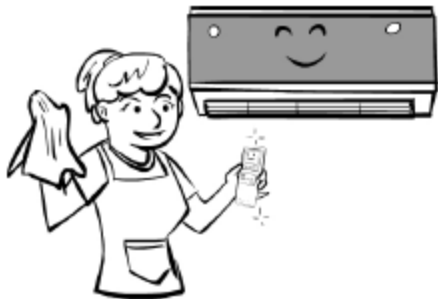

CLEANING THE AIR FILTERS;

1. Hold the two ends of the Grill and gently pull down the Filters to remove.	2. Use vacuum suction hose or a damp cloth to clean filters.	3. Leave to dry.	4.0 put the filters back in place, hold the two ends of the grill and gently push inwards until in place.
---	--	------------------	---

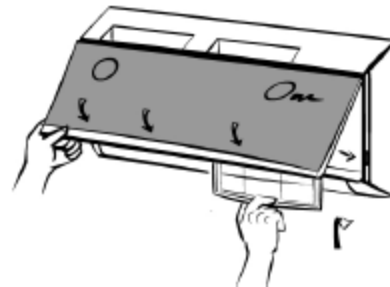
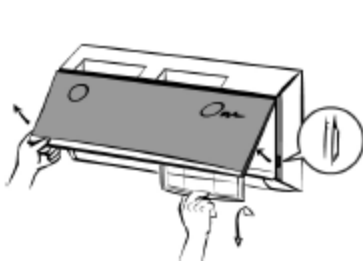

When the machine will not be used for a long period of time

- Run to dry the inside of the machine
- Pull out the power plug
- Take the batteries out of the remote control.

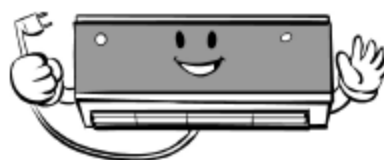
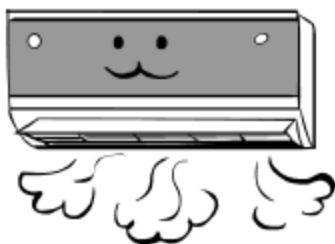

5- WATER HEATING CIRCUIT

1. The water heating circuit can be enabled/disabled with a switch located on the outdoor unit. It is the only user accessible on-off switch on the outdoor unit. Be careful not to touch nearby electrical connections. Make sure you are wearing gloves and shoes and are not standing in a wet area when operating this switch. The switch must be off until the outdoor unit is connected to the water lines/water tank per the installation instructions and there is water pressure established in the water circuit with all air purged from the water lines.
2. The circulation pump is a water-cooled unit. Allowing the water heating circuit pump to operate without water will damage the circulation pump and void the pump warranty. If in the future you must shut off your water supply and/or drain your water tank, make sure to disable the ACWH water heating circuit first. Alternatively, you can turn off the circuit breaker that supplies power to the ACWH to keep the pump (entire system) from running during a water outage.
3. The water heating controls are automatic. The recovery circuit will run when there is sufficient heat available for heat recovery water heating. This means the water heating circuit will probably be active whenever the system is running. To verify operation of the water heating circuit, carefully and temporarily peel back a small amount of water line insulation at a point near the outdoor unit and verify that the return line is hotter than the supply line.
4. If your unit was ordered with (-HL) high temperature limit option, the water heating circuit will turn itself off whenever the tank temperature is above 140F. If you do not have this option, note that the water temperature may get as hot as 158F. If you do not have the -HL option you must have a scald-valve (also called a mixing valve or tempering valve) installed on your water tank. WATER ABOVE 115F CAN SCALD. WATER AT 140F OR HOTTER CAN CAUSE SEVERE INJURY. A scald valve is recommended regardless of options installed.
5. If your system is equipped with Freeze Protection (option -FP) you must make sure the outdoor unit has power, the freeze protection circuit cycles tank water to keep the outdoor lines and heat exchanger from freezing. This action relies on the pump, which requires electricity. IF YOU HAVE FREEZE PROTECTION AND DURING FREEZING WEATHER YOU HAVE A POWER OUTAGE, IT IS HIGHLY RECOMMENDED THAT YOU CLOSE THE ISOLATION VALVES AND DRAIN THE WATER HEATING CIRCUIT or connect the system to a backup power source.

IF YOU DO NOT HAVE THE -FP FREEZE PROTECTION OPTION, YOU MUST DRAIN THE SYSTEM IN ADVANCE OF ANY FREEZING WEATHER CONDITIONS.
6. The pump uses an easily replaceable cartridge that contains all of the moving parts. If it needs to be replaced please consult a qualified technician. Contact HotSpot for a replacement cartridge.

6- TROUBLESHOOTING Cooling & Heating

6-1 Troubleshooting part 1

Symptom	Possible reason
REMOTE NOT WORKING	<ul style="list-style-type: none">• Make sure the batteries are inserted correctly• Batteries need to be replaced
LOW EFFICIENCY OF COOLING OR HEATING	<ul style="list-style-type: none">• Clean air filters• Clean evaporator on the indoor unit• Check H-Values
UNIT NOT WORKING IN THE HEAT MODE	<ul style="list-style-type: none">• Unit will restart after defrosting mode. Heating will resume after defrosting is done.
LOUD NOISE FROM THE UNIT	<ul style="list-style-type: none">• Clean air filters• Clean evaporator on outdoor unit• Check H-Values
VIBRATION IN OUTDOOR UNIT	<ul style="list-style-type: none">• Check H Values
WATER LEAKING FROM INDOOR UNIT	<ul style="list-style-type: none">• Moisture builds in the outdoor outlet due to the difference in temperature• Check the drainpipe
DISPLAY SHOWS AN ERROR CODE	<ul style="list-style-type: none">• Refer to the list of error codes

6-2 Please offer below information to repairman for better service.

H value

Press LOCK button 6 times with 7s on remote controller, there will display H value in indoor digital display, the details of H value see below,

H No	Description	Data
H1	Indoor air sensor temperature	
H2	Indoor pipe sensor temperature	
H3	Outdoor air sensor temperature	
H4	Outdoor pipe sensor temperature	
H5	Outdoor discharge sensor temperature	
H6	Compressor current	
H7	DC voltage	
H8	Compressor frequency	
Temperature set on remote controller		

Error code

Following are a list of error codes and meanings;

Item	Code	Fault	Check point	Count measure
1	E0	Outdoor sensor is faulty	Sensor value	Change sensor
2	E1	Indoor air sensor is faulty	Check connection or resistance of sensor	Reconnect or change the sensor
3	E2	Indoor pipe sensor is faulty		
4	E3	Indoor motor or indoor PCB is fault	Check motor Check indoor PCB	Change motor Change indoor PCB
5	E4	Outdoor PCB fault	Check outdoor PCB	Change outdoor PCB
6	E6	Outdoor sensor is not connected well or fault.	Check connection or resistance of sensor	Reconnect or change the sensor
7	F0	Self-protection due to electricity surge	Check outdoor PCB	Restart air conditioner or change outdoor PCB
8	P1	OCR tripped	1.Compressor OCR is open circuit	Change OCR
			2.The OCR temperature is too high	Turn off the air conditioner, and restart it half hour later
			3. The OCR is on and off regularly	Check if motors r runs, or if air outlet is blocked, or if heat exchanger is dirty
9	P4	Indoor unit does not match outdoor unit	Contact sales rep .	Change wrong unit
10	P8	Indoor motor feedback faulty		Change indoor PCB

Main Specifications For Cooling & Heating

Item	Data	Model	KFR-25	KFR-35	KFR-50	KFR-70
			GW/BMVE	GW/BMVE	GW/BMVE	GWZ/BM
Type			Cooling & Heating			
Cooling Capacity	(Btu/h)		9000	12000	18000	24000
Heating Capacity	(Btu/h)		9500	13650	18800	27000
Rated Voltage	(V)		230			
Rated Frequency	(Hz)		60			
Rated Cooling Power Input	(W)		641	918	1333	2400
Rated Heating Power Input	(W)		770	1064	1633	2550
Mass:indoor unit/outdoor unit	(lbs)		24/81	26/97	26/117	37/150
Air Flow:indoor unit	(m³/h)		500	650	720	1200
Design Pressure of High Side	(PSI)		500	500	500	500
Design Pressure of Low Side	(PSI)		250	250	250	250
Refrigerant:type/quantity	(lbs)		R410A/2.03	R410A/2.87	R410A/2.87	R410A/4.2

The pump consumes 90w of power. However, when the pump is running, waste heat is being recovered which lowers the head pressure of the compressor and lowers the motor torque causing an electrical savings of ~120w. at full operation. The unit will have lower overall electrical consumption when the heat recovery circuit is active, with no negative effect on cooling performance.