

XL48
SUNDOOME™

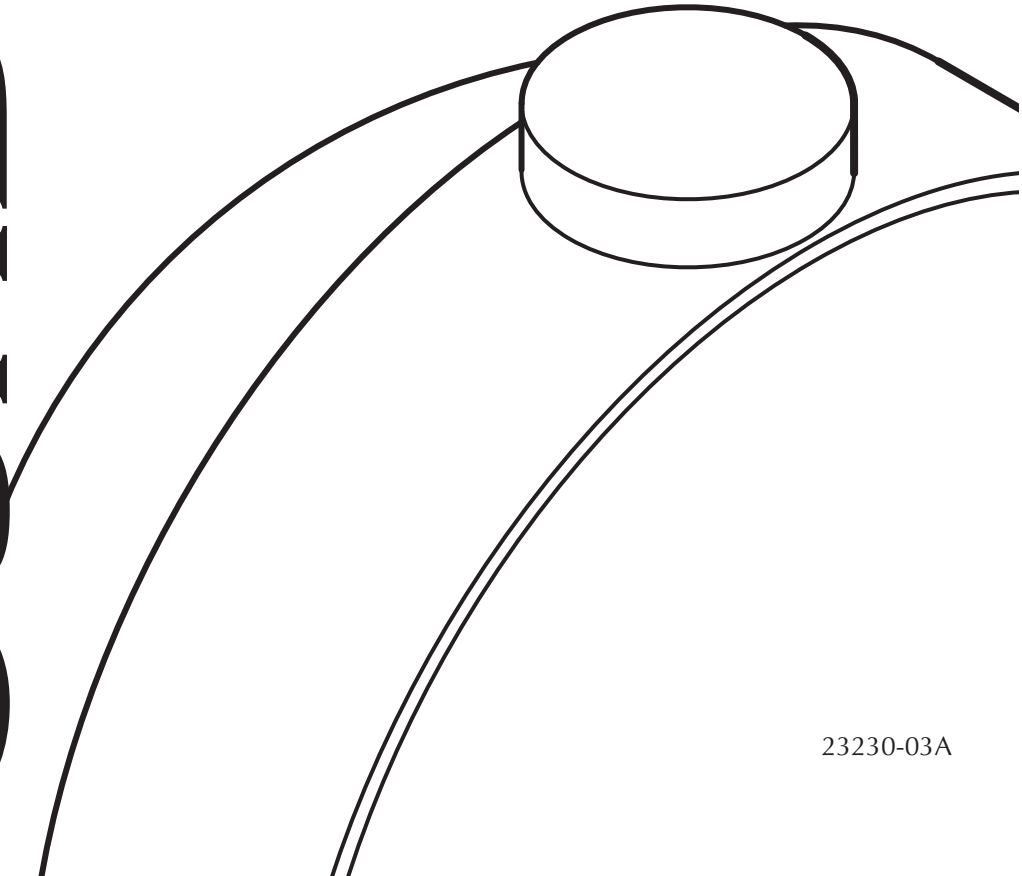

USER MANUAL



Limited Lifetime Warranty

SunDome™ warrants your tanning unit to be free of structural defects in its material and workmanship, under normal use, for its lifetime. **SunDome** will repair or replace, at their discretion, any defect to the structure which affects the performance of the unit.

For 6 months from the date of purchase, **SunDome** will provide replacements for parts that prove to be defective in material or workmanship. Acrylic shields, fluorescent lamps, and lamp starters are excluded from this warranty. Labor will be covered for 30 days from purchase date. Normal wear, damage from misuse or abuse, damage incurred in transit, or damage done by unauthorized repairs or modifications are not covered by this warranty.

ETS, Inc. disclaims any implied warranty of merchantability or fitness for any period beyond the expressed warranty. Some states do not allow limitations on how long an implied warranty lasts, so the above limitations may not apply to you.

No one has authority to change or modify this Limited Lifetime Warranty in any respect. To obtain service under the Limited Lifetime Warranty, contact **ETS, Inc.** at **1-800-449-3605**, and ask for the Technical Service Department.

ETS, Inc. shall not be liable for loss of use, loss of time, inconvenience, rental or substitute products, loss of business, loss of income, or any other incidental or consequential damages. Some states do not allow the exclusion or limitation of incidental or consequential damages, so the above limitation or exclusion may not apply to you.

This warranty gives you specific legal rights, and you may also have other rights which may vary from state to state.

All warranty service must be performed by an authorized service person. If your tanning unit must be returned for service, all freight charges must be at your expense. Contact your place of purchase for the address of the **SunDome** Service Center nearest you. Proof of purchase is required to obtain warranty service.

This warranty covers the original purchaser only. This warranty is void if the unit is modified in any manner from its original design.



Welcome

Congratulations on your purchase of this technologically advanced sun tanning unit. It has been designed to provide years of dependable service for you.

Please read all the instructions in this booklet before installing and using the unit. Always be sure to observe all safety precautions.

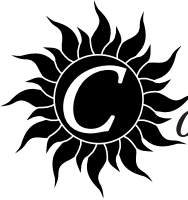

Contents

- Safety Information** *.iii*
- Installation** **1**
 - Unpacking and Inspection 1
 - Pre-Installation Planning 2
 - Tools Required 3
 - Hardware Inventory 4
 - Assembly Procedures 5
 - Electrical Connections 18
 - Remote Connections 19
- Operation** **22**
 - Before You Tan 22
 - Exposure Times 22
 - Using Your Booth 23
- Care and Maintenance** **25**
 - Cleaning After Use 25
 - Thorough Periodic Cleaning 25
 - Mechanical Inspection 25
 - Lamp and Grill Maintenance 26
- Troubleshooting** **27**



Safety Information

LABELING NOTICE: Labels are affixed on all systems to inform the user of possible dangers. Regulations are stated in 21 CFR, Section 1040.20, and require that all products manufactured after September 8, 1986 which use sunlamps must display the following:

DANGER Ultraviolet radiation. Follow instructions. Avoid overexposure. As with natural sunlight, overexposure can cause eye and skin injury and allergic reactions. Repeated exposure may cause premature aging of the skin and skin cancer. **WEAR PROTECTIVE EYEWEAR; FAILURE TO MAY RESULT IN SEVERE BURNS OR LONGTERM INJURY TO THE EYES.** Medications or cosmetics may increase your sensitivity to the ultraviolet radiation. Consult physician before using sunlamp if you are using medications or have a history of skin problems or believe yourself especially sensitive to sunlight. If you do not tan in the sun, you are unlikely to tan from the use of this product.

For a uniform tan, center yourself within the booth both front and back and to the left and right. This will result in your body being equidistant from all lamps. Other positions may result in overexposure to parts of your body. Do not use without metal grids in place. Untanned persons should not tan on consecutive days during their first week of tanning. Never tan more than once a day. Tanning normally appears after the first few sessions and maximizes after approximately four weeks. Tan once or twice per week thereafter to maintain appearance. Persons already having a base tan may begin at advanced levels corresponding to the extent of their base tan.

RECOMMENDED EXPOSURE TIMES IN MINUTES		MAXIMUM EXPOSURE TIME IS 10 MINUTES				
Skin Type:		Level 1/Week 1 1st-3rd Sessions	Level 2	Level 3	Level 4	Subsequent Maximum
I Sensitive Skin (Burns easily and severely and does not tan.)		NOT RECOMMENDED FOR TANNING				
II Light (Burns easily and severely and tans minimally.)		2	4	6	8	10
III Normal (Burns moderately and tans average.)		3	5	7	10	10
IV Dark (Burns minimally, tans easily and above average.)		4	6	8	10	10

New lamps emit approximately 10% more ultraviolet radiation during the first 50 hours of operation. Recommended tanning times should therefore be reduced by approximately 10% during that period.

WARNING: • Read the instructions booklet before using this sunlamp product. • All persons in the room should wear protective eyewear when lamps are on. Recommended eyewear: provided eyeshields (Lucas Products Super Sunnies) or equivalent eyewear as defined under 21 CFR 1040.20. Other types of eyewear may not provide adequate protection.

ONLY THE FOLLOWING LAMPS HAVE BEEN CERTIFIED FOR USE IN THIS EQUIPMENT:

- MEGA VOLTAGE™ GOLD SERIES VS-R™ Model MV75R-T12-160W VS-R Bi-Pin
- Velocity® VS-R™ Wolff® Model VEL75-T12-160W VS-R Bi-Pin

DISCONNECT POWER CORD BEFORE ATTEMPTING TO CLEAN, RELAMP, OR ENGAGE IN THE MAINTENANCE OF THIS PRODUCT.

THIS EQUIPMENT MUST BE EARTH GROUNDED.

THIS PRODUCT IS IN CONFORMITY WITH PERFORMANCE STANDARDS FOR SUN LAMP PRODUCTS UNDER 21 CFR PART 1040.20



Unpacking and Inspection

The SunDome™ comes in seven boxes. For ease of assembly, after inspection you may want to leave everything in its box until called for in the assembly instructions.

Open each box and inspect the contents and make sure they are free from any visible damage. Report the extent of any damage to the transportation company.

Note! The cartons are reusable, in the unlikely event that you may find it necessary to return your equipment.

As you unpack your boxes you should find the following:

- Control Module (box 1)
- Bag containing necessary assembly hardware, and safety goggles (box 1)
- Left Module (box 2)
- Right Module (box 3)
- Left Door (box 4)
- Right Door (box 5)
- Dome Assembly (box 6)
- Pedestal (box 7)
- Two Long Handles
- Two Long Trim Profiles

Record the serial number of the control module in the area provided at the back of this manual. This information will be required if you ever need to call customer service.



Pre-Installation Planning

Before you begin to assemble your booth, you should observe the following considerations.

- Your booth operates from a 220V AC power source. The unit should be wired to a dedicated circuit as described below. We recommend connection by a professional electrician.
- IMPORTANT! Voltage must be below 230V AC or may require a Buck Booster. Contact ETS service at the number on the back of this guide. Use of a voltage source above 230V AC may reduce the life of some components in your unit.
- The SunDome™ requires a dedicated circuit capable of providing 60 Amp service. This unit must be hard-wired directly to a junction box.
- Make sure the room in which you intend to use your booth is well ventilated. Air from the room is used to cool the unit, and a poorly ventilated room may cause the unit to become hot and cause discomfort to the user.
- Your booth is designed to operate in an ambient room temperature of 80°F maximum and 70% relative humidity.
- Place your booth no closer than 6" from any wall. Make sure that curtains, drapes, and other room furniture do not obstruct the airflow into or out of the fan opening areas.
- Proper assembly of your booth requires two people. Plan to have a helper, or two, assist you.



Tools Required

You will need the following tools to assemble your booth.

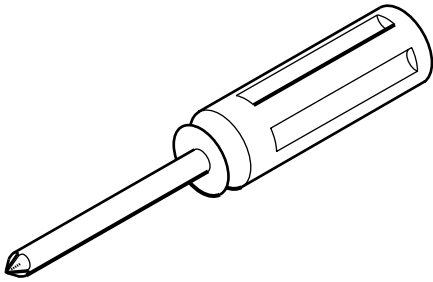

#2 Phillips Screwdriver

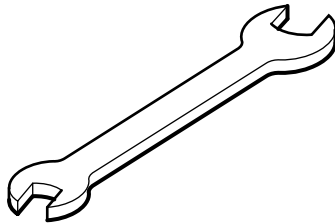

7/16" Wrench
(or adjustable wrench)



Hardware Inventory

Open the hardware bag and remove the hardware. Make sure you have the following hardware items.

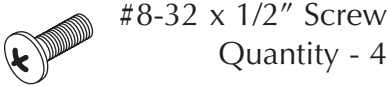

#8-32 x 1/2" Screw
Quantity - 4



#8-32 Nut
Quantity - 4

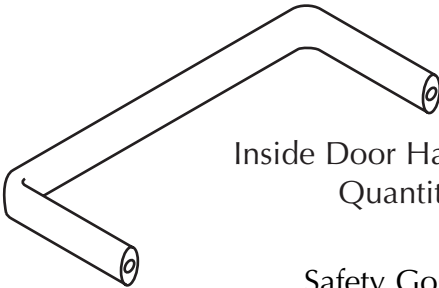

Inside Door Handle
Quantity - 2

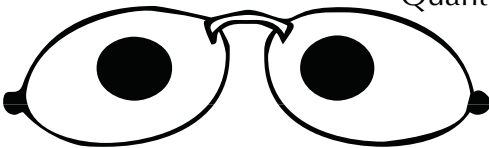

Safety Goggles
Quantity - 1

Other hardware found in Box 6

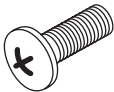

#10-32 x 1/2" Screw
Quantity - 4



#10 x 1/2" Screw
Quantity - 4

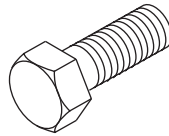

1/4-20 x 3/4"
Hex Head Bolt
Quantity - 9

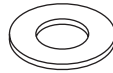

1/4" Flat Washer
Quantity - 9

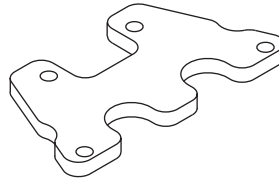

Joint Plate
Quantity - 2

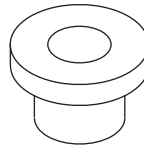

Bronze
Hinge Bushing
Quantity - 4

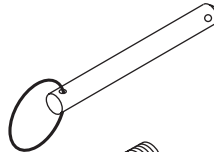

Hinge Locking Pin
Quantity - 4

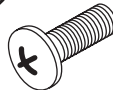

#10-32 x 1/2" Screw
Quantity - 4

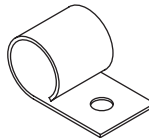

Wire Clamp
Quantity - 2

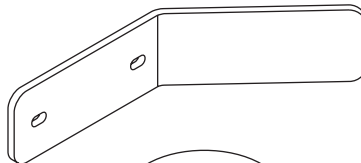

Magnet
Strike Plate
Quantity - 2

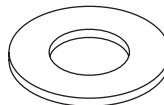

Shim Washer
Quantity - 4



Assembly Procedures

Put the pedestal (found in *box 7*) in the general area you want the booth. Leave some space around the pedestal to work.

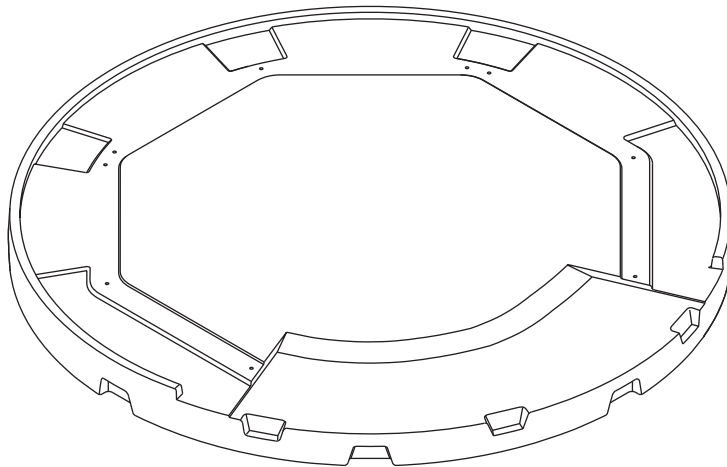

FRONT



Parts needed:

Control Module (box 1)

Left Module (box 2)

Right Module (box 3)

CONTROL MODULE
(with power cable on back)

Remove these two screws and lift the grill from the unit. Repeat for the other grills.

LEFT MODULE

NOTE: Wiring has been deleted to show details.

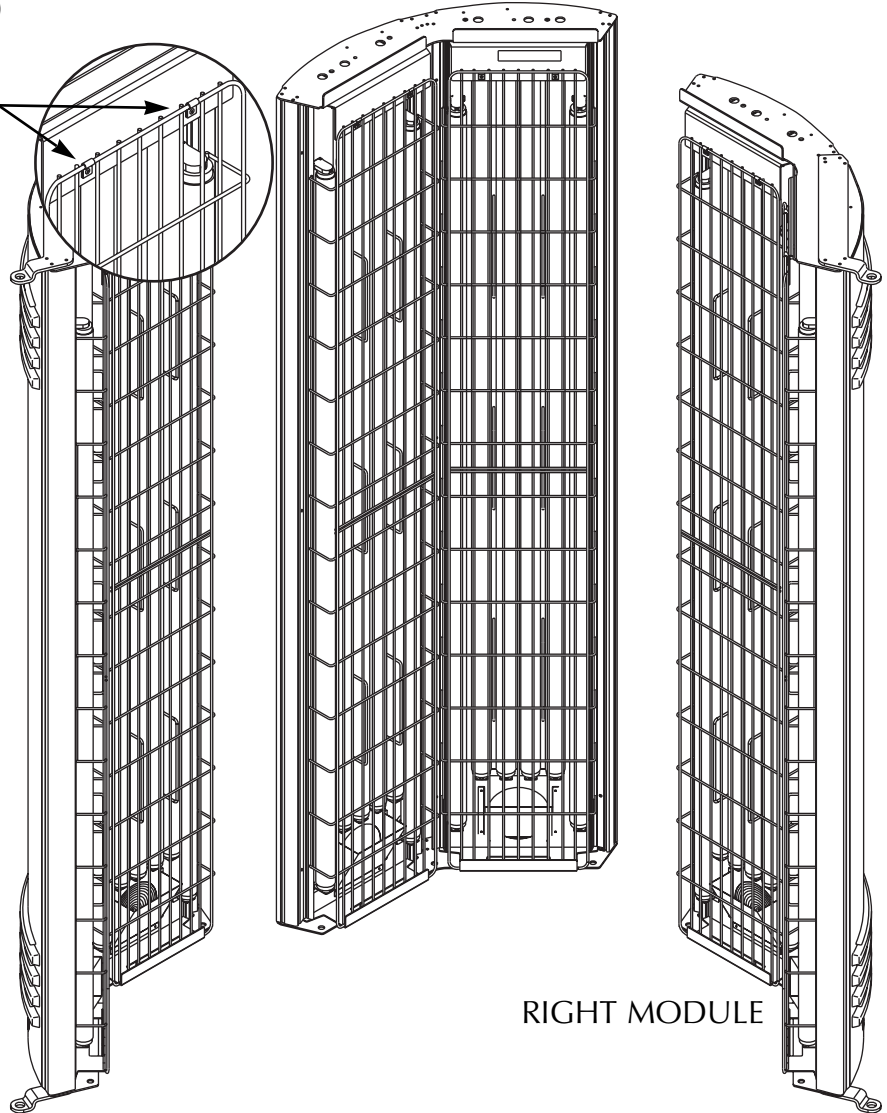

RIGHT MODULE



Parts needed:
Left Module
Right Module
2 - Long Handles

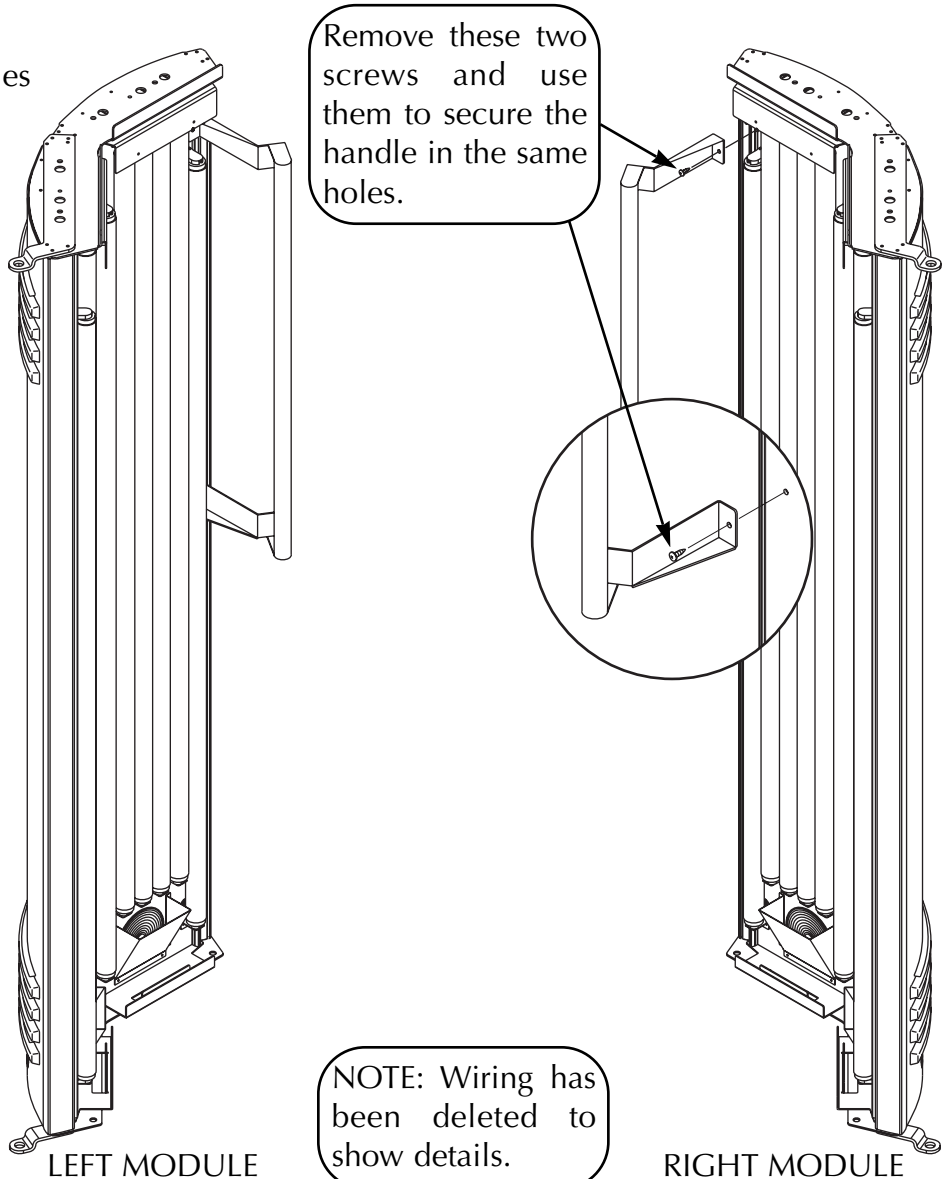



Parts needed:

Control Module

Left Module

Right Module

9 - 1/4-20 x 3/4" Hex Head Bolts

9 - 1/4" Flat Washers

Attach modules to pedestal with three bolts and washers each, as shown.

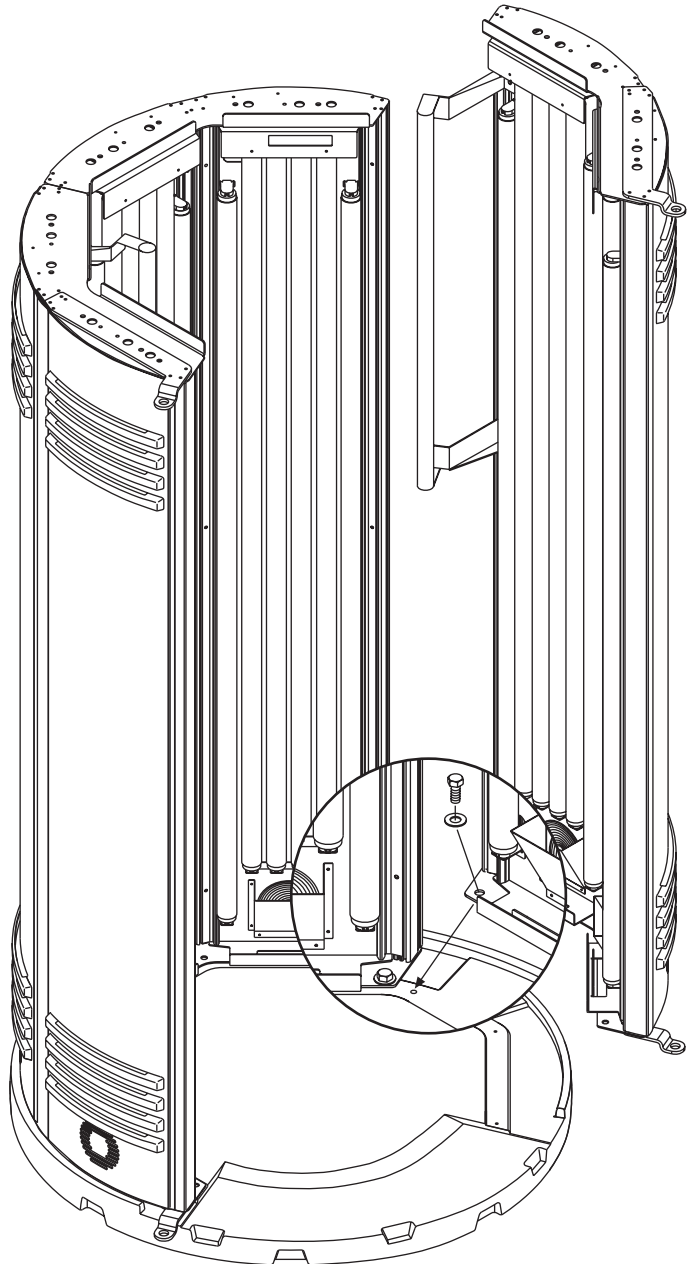

NOTE: Wiring has been deleted to show details.



- Parts needed:
2 - Joint Plates
2 - Wire Clamps

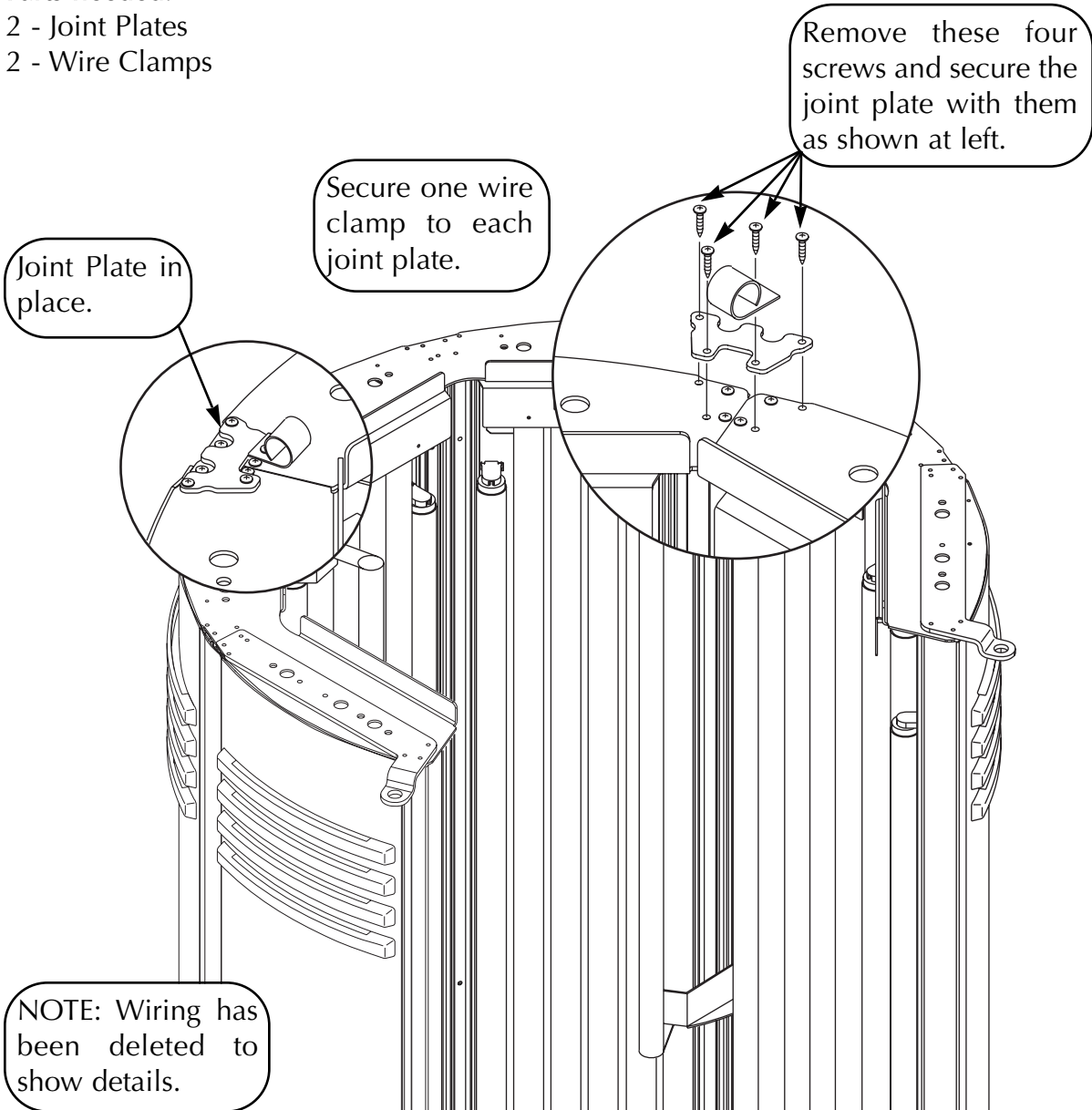



Parts needed:

2- Inside Door Handles

4 - #10-32 x 1/2" Screws

1

If not already done, you will need to remove the grills from both doors.

2

Secure handles with screws through the double grid pattern on each door grill.

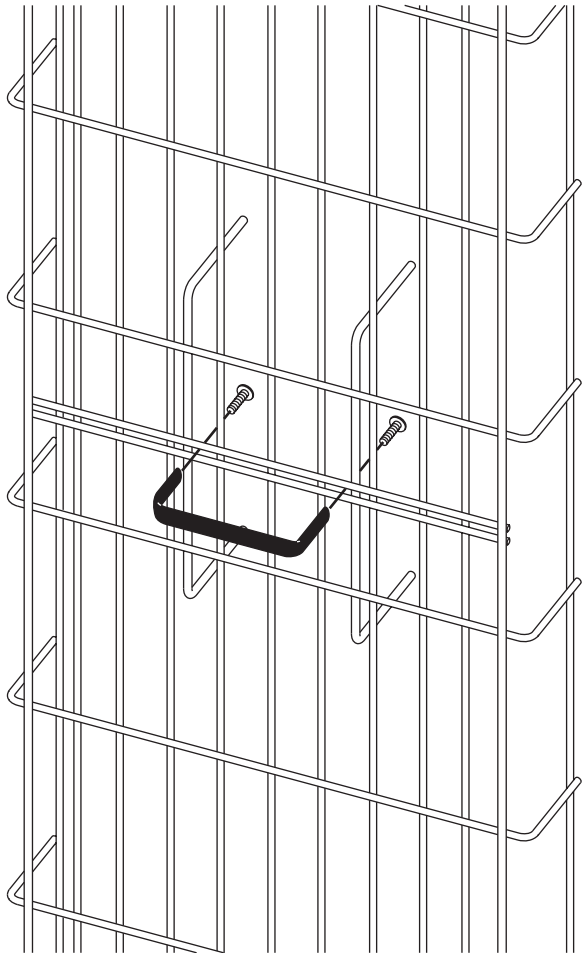



Parts needed:
Grills (removed earlier)
2 - Trim Profiles

Reinstall the grills.

Insert trim profiles into space between right and control module, and between left and control module.

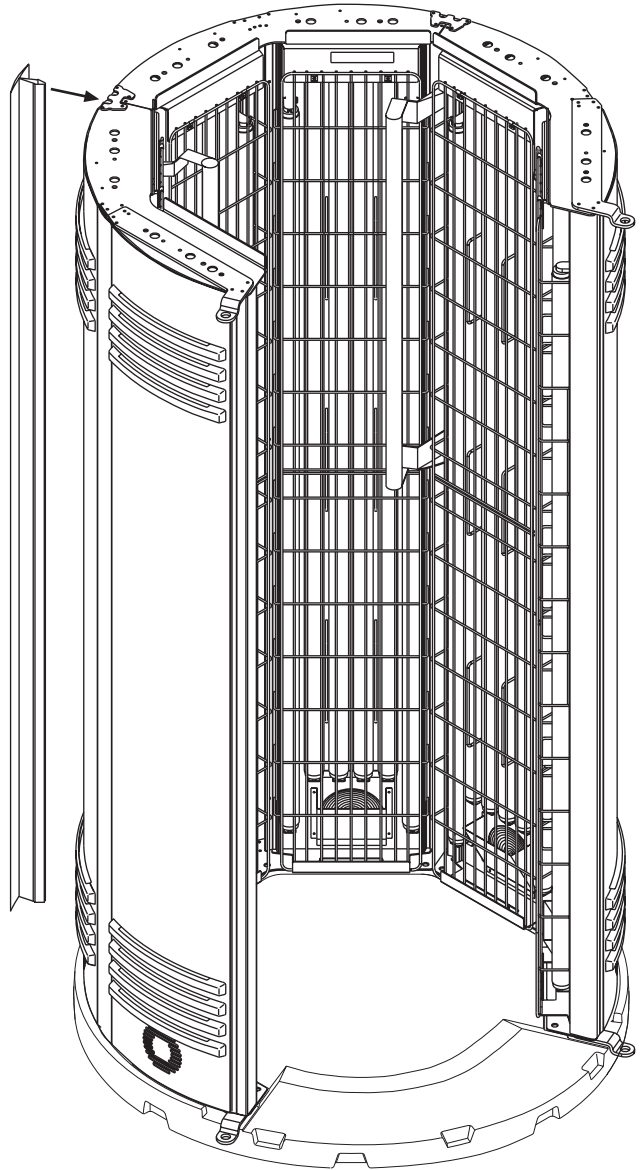

NOTE: Wiring has been deleted to show details.



Parts needed:

Left Door (box 4)

Right Door (box 5)

4 - Hinge Bushings

4 - Hinge Locking Pins

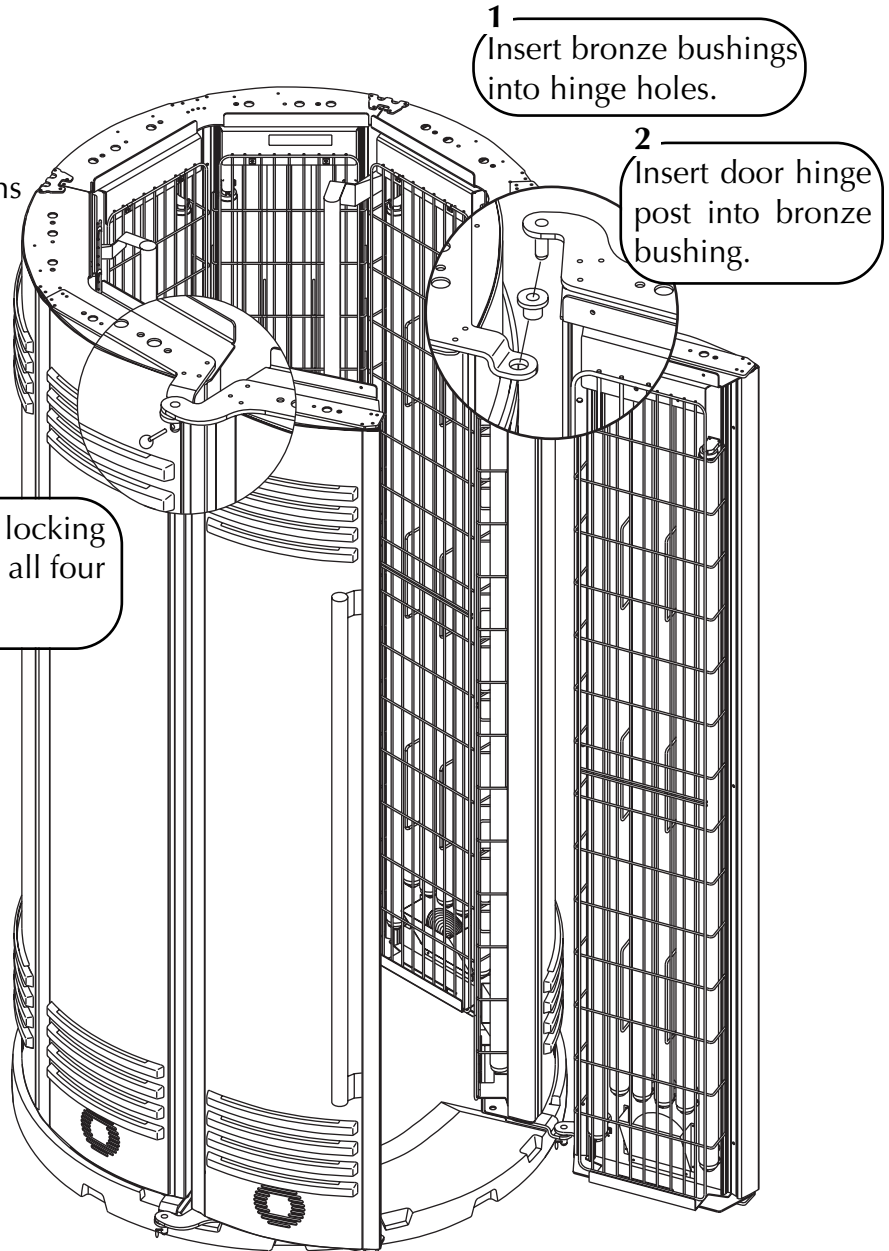

If a door rubs the pedestal, install a shim washer on the hinge post over the bronze bushing on both the upper and lower hinges of the affected door.

NOTE: Wiring has been deleted to show details.



Parts needed:

- 2 - Magnet Strike Plates
- 4 - #8-32 x 1/2" Screws
- 4 - #8-32 Nuts

Install magnet strike plates with two screws and two nuts each. To achieve proper positioning, close the doors and make sure magnets at the top of the doors contact the magnet strike plates.

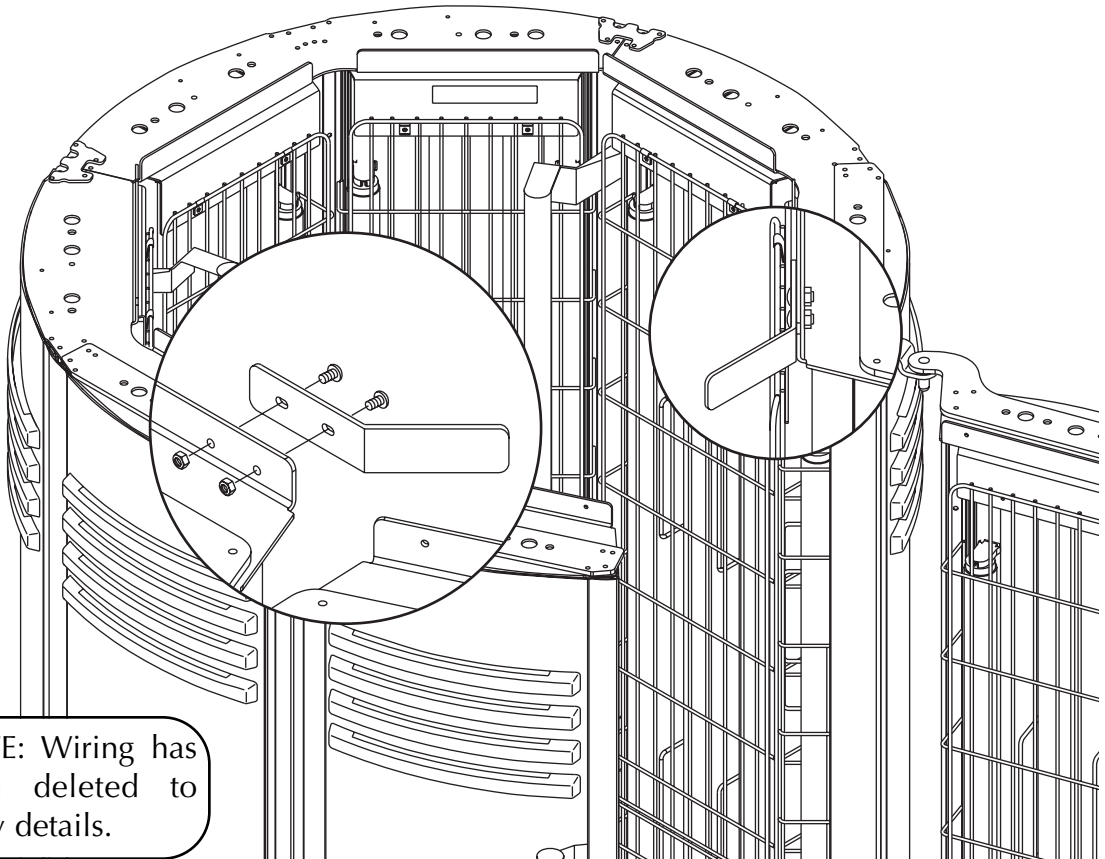

NOTE: Wiring has been deleted to show details.



There are five cables coming out of the top of the control unit. Two cables have a twelve pin connector (see illustration at right) and the other three have a six pin connector. Wire the booth as shown below, making sure all wiring is secured in any wire clamp it may pass.

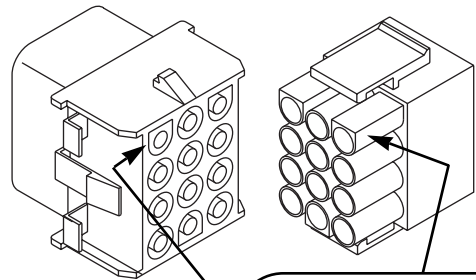

Notice the squared pins and holes for easy connection.

Leave short 6 pin cable loose.

12 pin connector.

12 pin connector.

6 pin connector.

6 pin connector.

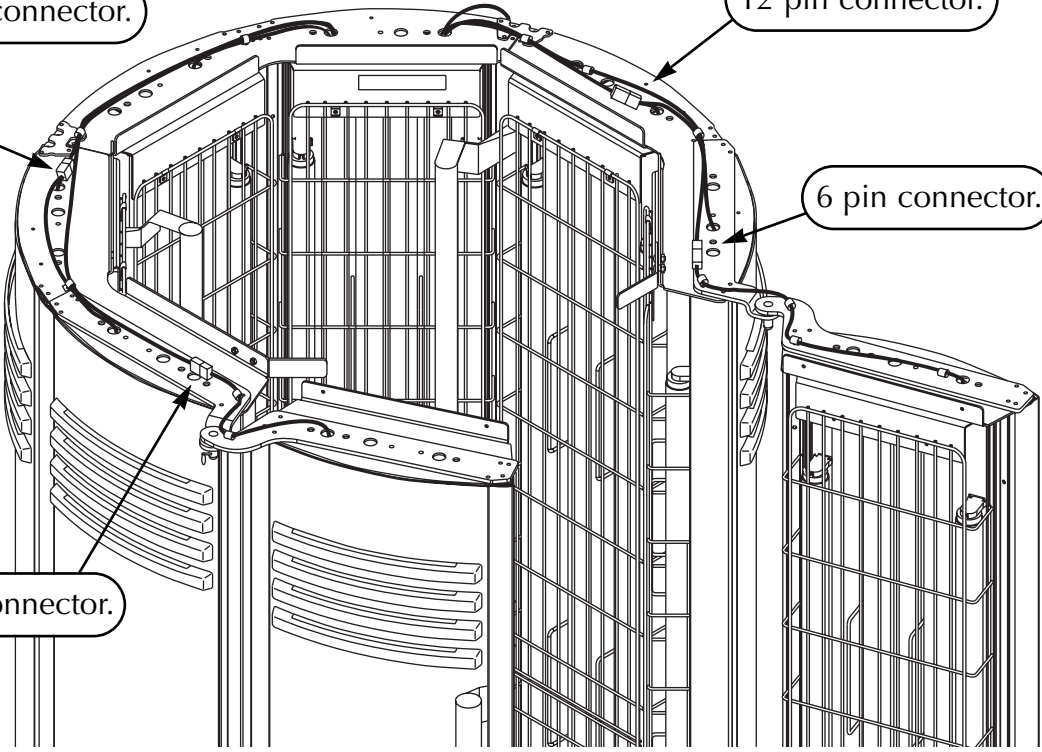



Parts needed:
Body Fan / Speaker Assembly (box 6)
4 - #10-32 x 1/2" screws

Make sure cable connector is on this side.

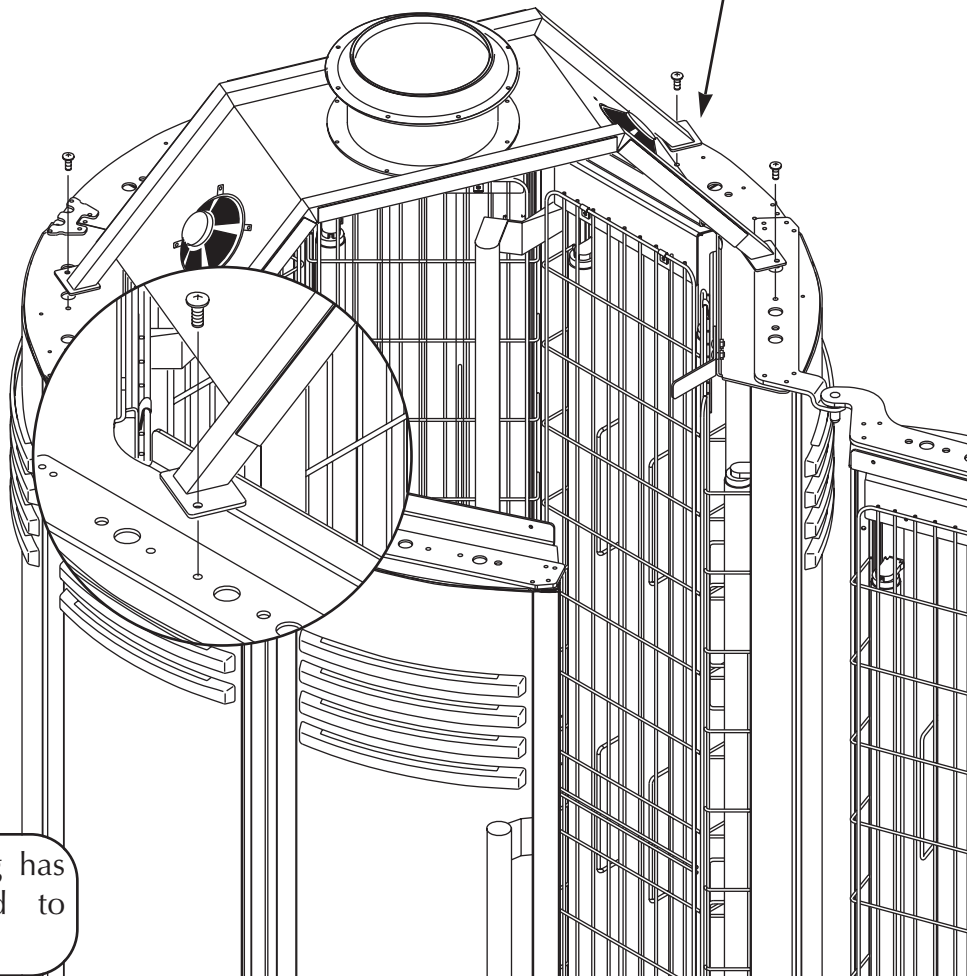



The fifth cable, left loose earlier, goes to the Body Fan / Speaker Assembly. Bring the cable around the assembly leg and connect it to the 6-pin cable on the assembly. Again, secure the cable in any wire clamps it passes.

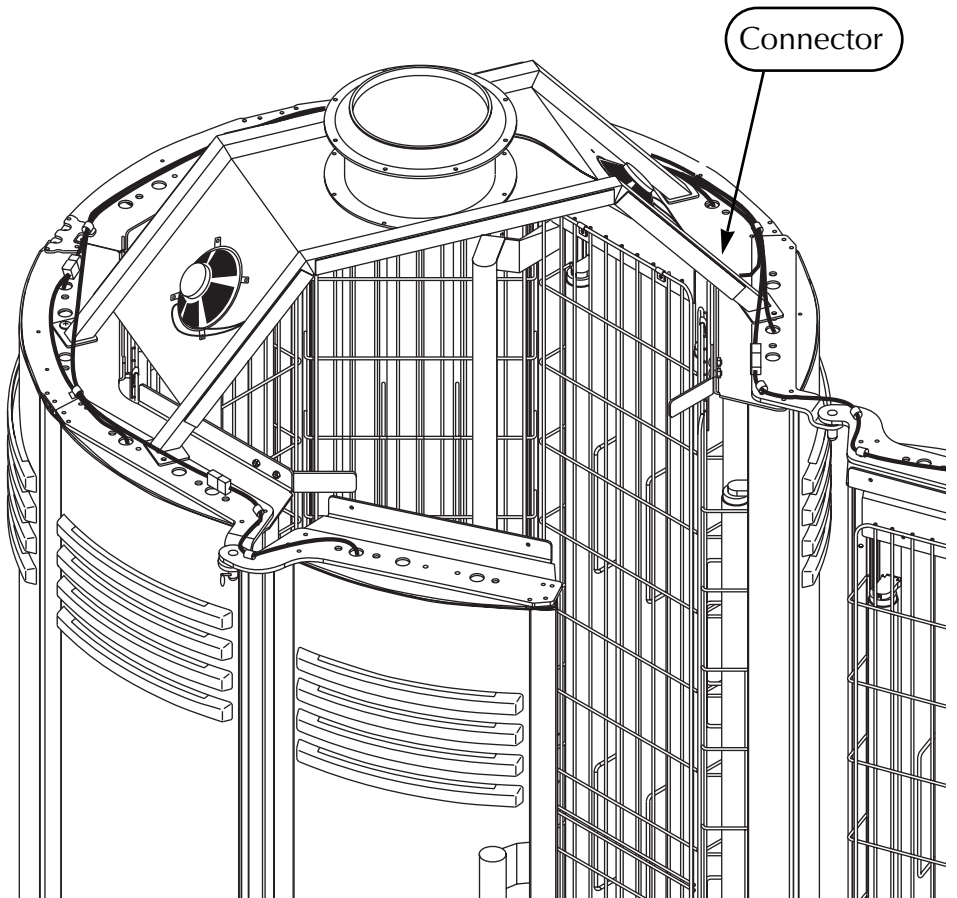



Parts needed:

Dome (box 6)

4 - #10 x 1/2" screws

Secure the dome in place with the four screws, as shown. Be sure not to pinch any wires.

When installing the dome, notice the two small pins located on top of the unit (shown below). Make sure the dome fits between these two pins when installed. You may need to squeeze the dome slightly.

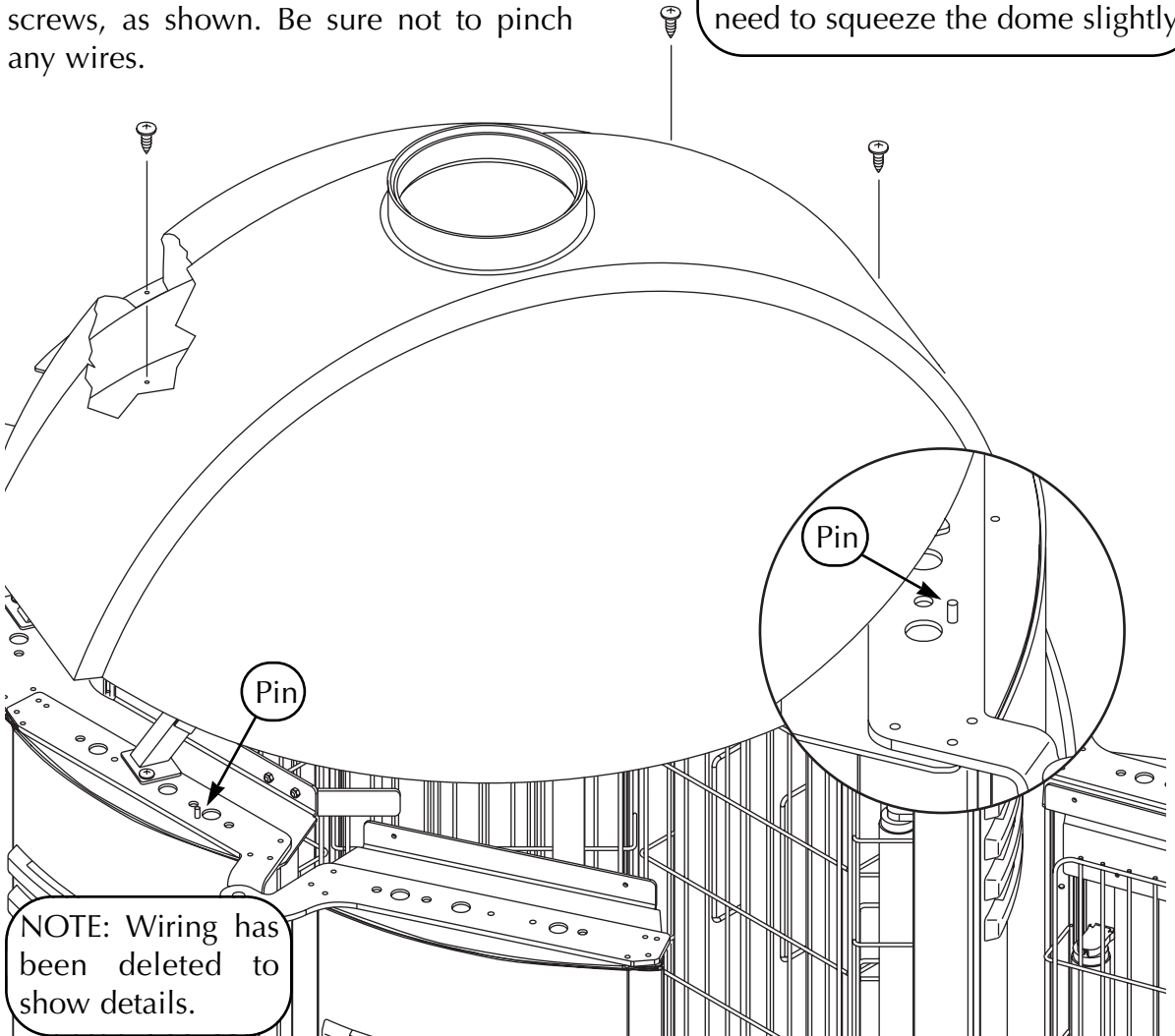



Electrical Connections

At the rear of the booth is an armored power cable. Connect power cable as described in *Pre-Installation Planning*. Again, a professional electrician is recommended. A Remote Control Bypass plug is already installed in one of the remote control ports as shown. Your booth will not operate without the Remote Control Bypass plug or a remote system connected. Your equipment is now ready for use.

In the dome of the SunDome™ booth are two speakers capable of handling 25W of musical power, with a maximum of 80W. Just above the power cable are two speaker inputs to connect to a stereo.

NOTE: Your unit is designed to accept an input from a remote control device. The remote control is optional. If you plan on using a remote system refer to *Remote Connections*.

ATTENTION: Although the Remote Control Bypass plug provided with your unit will work wherever a T-Max® terminator is called for in the series, the T-Max® terminator will not work as a bypass plug. A bypass plug is needed only when your booth is operated without a remote system connected.

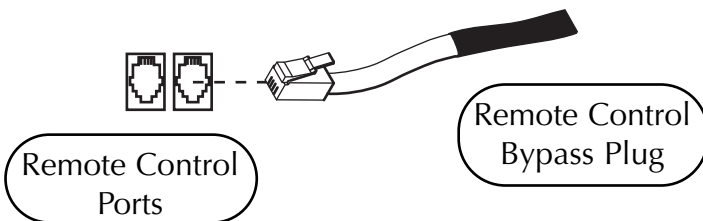



Remote Connections

Your tanning booth incorporates advanced circuitry allowing it to connect and communicate with most remote control systems. If a remote system is to be used, first determine whether the remote system is a T-Max® System or a standard remote system operating with a control relay. Follow the appropriate instructions for your system type.

Warning: The remote connection is not designed to supply or accept high voltage, nor can it provide power to an external timer. The booth's remote interface circuitry operates on 5 volts, attempting to connect it to any higher voltages will damage the unit as well as void your warranty.

T-Max® Products

The T-Max® remote systems offer the ultimate in sunbed control, while allowing the tanner easy straightforward operation. Your booth is configured to directly connect to this system. The circuitry inside your booth eliminates the need for the T-Max® 1A or 3A when connecting to the T-Max® Manager series. Your booth supports the auto addressing feature of the latest T-Max® Manager models and the following parameters: 2, 5, 6, 7, 8, 9, 10, 14, and 15. See your T-Max® manual for descriptions of these parameters and how they function.

T-Max® Manager Remote System

This system is ideal for multiple sunbed installations. Simply connect the RJ-22 modular cable(s), described in the T-Max® Manager manual, into the remote port(s) located on the back of your booth and follow the instructions that came with your remote system, noting *figure 1*. If you have an older T-Max® Manager that doesn't support auto addressing, set the address, or "id", of each unit manually as described in *Setting the address manually*. You can place your booth at any location in the series.

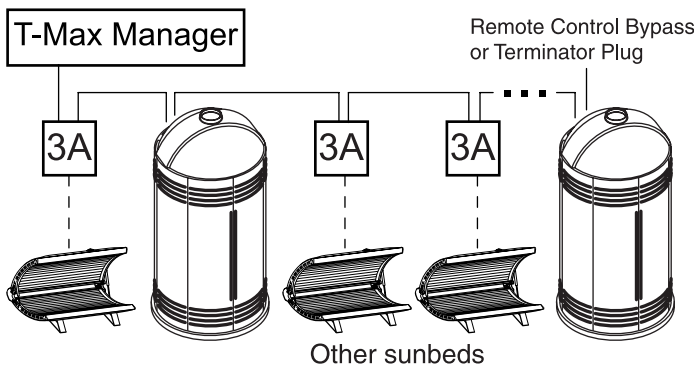

figure 1

NOTE: A T-Max® 1A can be substituted for the 3A in figure 1.



T-Max® 1A and 3A Remote Systems

The T-Max® 1A and 3A offer the same control as the T-Max® Manager in single unit installations. If you're using a 1A, it must have a chip labelled "master" installed on its circuit board. The remote control bypass plug must not be used in this configuration.

After you have set the T-Max® 1A's, or 3A's, address to "0" (refer to your T-Max® user's guide) and the booth's address to "1" (see right), simply connect the RJ-22 modular cables, described in the T-Max® user's guide, directly into either port located on the back of the unit and either port on the back of the T-Max® 1A or 3A. See figure 2.

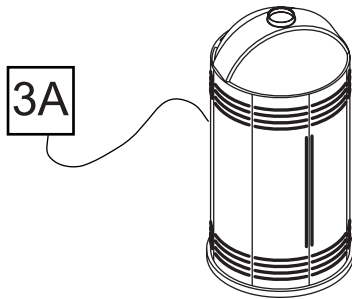

figure 2

NOTE: A T-Max® 1A with a "master" chip can be substituted for a 3A in figure 2.

Setting the address manually

Before connecting your booth to the T-Max® Manager or T-Max® 1A or 3A, the address of your booth must first be set. Set the "id" manually as described below.

Setting the "id"

1. Make sure no cables are plugged into your booth's remote ports.
2. Remove and reapply power to the unit.
3. Press and hold the stop button, located on the timer display, for three seconds and release. The display should indicate an "id" number from "oF" to "252".

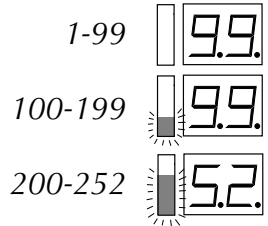

4. If you are using a T-Max® 1A or 3A as your remote, the "id" of the unit must be set to "1". If you are using a T-Max® Manager each unit must be assigned a different "id". To set the "id" press the timer button to count up until the desired number is achieved.
5. Press the stop button to return to the normal display mode.



Remote systems using a Control Relay

Most non-T-Max® remote systems control the unit by the use of a relay. The relay operates the unit by connecting and disconnecting a pair of wires leading from the unit. Refer to the user's manual provided with your remote system to determine if it operates in this way. To connect your booth to this type of system a remote interface kit is required. Call ETS at the phone number listed on the back of this guide to obtain the kit. *Figure 3* details a typical connection. Follow the instructions provided with the kit and from the remote's manual to make the necessary connections.

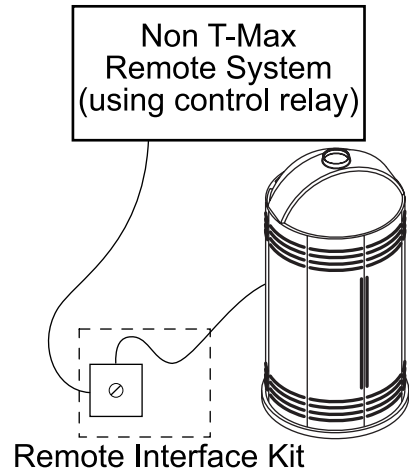

figure 3



Before You Tan

Before using your tanning booth, please note the following important precautions.

- Your skin should be free of cosmetics, tanning oils, or other body lotions prior to tanning except for those specifically made for use with tanning devices. However, do not remove natural body oils by bathing or showering immediately before tanning.
- As with all electrical appliances, do not operate this device near water or while you are wet.
- Some medications may increase your sensitivity to ultraviolet light. It is recommended that you consult a physician before using this tanning booth if taking any medication or if you suspect that your skin might be especially sensitive to sunlight. Included with this manual is an FDA booklet on medications that increase sensitivity to light.

Exposure Times

Follow the guidelines for skin type and exposure times as shown in the table below. Untanned persons should not tan on consecutive days during their first week of tanning. Never tan more than once a day. Tanning normally appears after the first few sessions and maximizes after approximately four weeks. Tan once or twice per week thereafter to maintain appearance. Persons already having a base tan may begin at advanced levels corresponding to the extent of their base tan.

RECOMMENDED EXPOSURE TIMES IN MINUTES		MAXIMUM EXPOSURE TIME IS 10 MINUTES				
Skin Type:	Level 1/Week 1 1st-3rd Sessions	Level 2	Level 3	Level 4	Subsequent Maximum	
I Sensitive Skin (Burns easily and severely and does not tan.)	NOT RECOMMENDED FOR TANNING					
II Light (Burns easily and severely and tans minimally.)	2	4	6	8	10	
III Normal (Burns moderately and tans average.)	3	5	7	10	10	
IV Dark (Burns minimally, tans easily and above average.)	4	6	8	10	10	



Using Your Booth

When connected to the T-Max® Manager or T-Max® 1A or 3A.

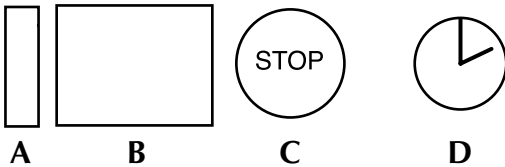

- A Address Indicator** - Used for addressing unit (See Remote Connections). Also illuminates when unit is running.
 - B Timer display** - Displays remaining time.
 - C Stop button** - Interrupts tanning session.
 - D Timer button** - Turns unit on. Timer display shows remaining time. If a lesser time is desired, press timer button until desired time is displayed.
1. Open the doors, step inside and close the doors fully. For best results, position your body in the center of the booth.
 2. Put on your safety goggles.
 3. Assuming the remote system has been set to allow a pre-tanning delay time, the timer display (B) will repeatedly flash the delay symbol "dL" and then the remaining delay time. Press the timer button (D) or wait until the delay time has expired to begin the tanning session. The lamps will turn on and the timer will begin to count down.
 4. If a tanning time less than the displayed time is desired repeatedly press the timer button (D) to decrease the remaining time.
 5. When the timer reaches 0 the lamps turn off. If you want to stop your session before time expires, press the stop button (C).
 6. Exit the booth. If you become disoriented there are "EXIT" signs over the doors. The cooling fans run for three minutes after the lamps shut off to aid in cooling the booth. The timer will indicate ".." as a reminder to clean the tanning surfaces. After the booth is cleaned press the timer button and the display will return to "0".



Using Your Booth

When used as a stand alone unit or when connected to a remote system using a control relay.

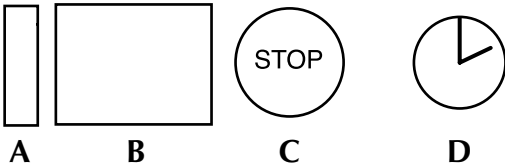

- A Address Indicator** - Used for addressing unit (See Remote Connections). Also illuminates when unit is running.
- B Timer display** - Displays remaining time.
- C Stop button** - Interrupts tanning session.
- D Timer button** - Turns unit on. Timer display shows remaining time. If a lesser time is desired, press timer button until desired time is displayed.

1. Open the doors, step inside and close the doors fully. For best results, position your body in the center of the booth.
2. Put on your safety goggles.
3. Press the timer button (D) to begin the tanning session. The lamps will turn on and the timer will begin to count down.
4. If a tanning time less than the displayed time is desired repeatedly press the timer button (D) to decrease the remaining time.
5. When the timer reaches 0 the lamps turn off. If you want to stop your session before time expires, press the stop button (C). You will have ten seconds to restart with the remaining time, otherwise the timer will reset to 0.
6. Exit the booth. If you become disoriented there are "EXIT" signs over the doors. The cooling fans run for three minutes after the lamps shut off to aid in cooling the booth. The timer will indicate ".." as a reminder to clean the tanning surfaces. After the booth is cleaned press the timer button and the display will return to "0".



are and Maintenance

Cleaning After Use

Clean and disinfect your tanning booth's grills, handles and pedestal after each use. Use a non-abrasive disinfectant cleaner that **does not contain ammonia or ammonia derivatives**. Wipe the grills with a soft cloth dampened with disinfectant and wipe dry with a clean soft cloth. We recommend SunQuest® disinfectant and SunQuest® acrylic cleaner.

Thorough Periodic Cleaning

Introduction

The cooling fans draw air through the unit and over time will cause a dust buildup on the lamps and reflectors. This will reduce the tanning effectiveness of the booth. When a dust buildup is observed, it is necessary to thoroughly clean the inside of the unit. **Warning!** Disconnect sunbooth from electrical power before cleaning.

Cleaning the SunDome™

- Step 1** Remove the metal grills and lamps as described in *Lamp and Grill Maintenance*.
- Step 2** With a soft cloth, wipe the entire length of each lamp to remove any film buildup.

- Step 3** Thoroughly clean grills with a disinfectant cleaner.
- Step 4** Wipe the reflectors with a clean damp cloth.
- Step 5** Re-install the lamps and grills.

Mechanical Inspection

Your tanning booth has been built for years of service. To ensure trouble-free operation throughout its life, inspect the unit's mechanical integrity every 400-500 hours of use.

- Inspect the unit's fasteners verifying that all are firmly in place.
- Inspect hinges for signs of wear. If your hinges squeak you need only replace the bronze bushings. See *Troubleshooting*.
- Inspect the AC power cord and its connections.



Lamp and Grill Maintenance

Introduction

To be assured of maximum tanning effectiveness, change lamps after approximately 800-1000 hours of use. Tanning will continue after this time but at a slower rate. To ensure trouble-free operation of your booth, replace the lamp starters whenever the lamps are replaced.

Warning! Disconnect unit from electrical power before servicing.

Removing/Replacing Metal Grills

The metal grills are secured in place by two screws at the top of each grill. Simply remove these screws and lift the grill out of its channel at the bottom. Repeat for the other grills. The lamps are now exposed.

After changing the lamps, replace the metal grills by setting them into their channels and securing in place with their screws at the top.

Removing/Replacing Lamps

After removing the metal grills, replace lamps as follows.

- Step 1 Grasp the lamp at one end and at the middle and turn the lamp one quarter turn. Gently remove the lamp from its holders.
- Step 2 Reinstall the lamp by inserting the pins located on the ends of the lamp into the slots on top of the lamp holders and turn the lamp a quarter turn. It should click in place.

Recommended Replacement Lamps

We recommend using the lamps specified below. Use of uncertified lamps is a violation of Federal regulations and will void your warranty. These lamps have an average life of 800-1000 hours of effective tanning use. Lamps used longer than that begin to lose their effectiveness even though they continue to light.

ONLY THE FOLLOWING LAMPS HAVE BEEN CERTIFIED FOR USE IN THIS EQUIPMENT:

MEGA VOLTAGE™ GOLD SERIES VS-R™ Model MV75R-T12-160W VS-R Bi-Pin

Velocity® VS-R™ Wolff® Model VEL75-T12-160W VS-R Bi-Pin

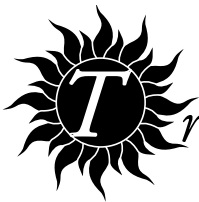

Troubleshooting

Problem	Solution
Unit not tanning	<ol style="list-style-type: none"> 1. Clean unit, see <i>Thorough Periodic Cleaning</i>. 2. Ensure supply voltage is between 208 and 230V AC. 3. Replace lamps if lamp hours are greater than 800hrs.
Lamps fail to light and timer display is blank	<ol style="list-style-type: none"> 1. Make sure the unit is connected to a power source. 2. Check source of AC power. Reset circuit breaker or replace fuse.
Timer display changes to indicate a tanning time after the timer button is pressed but lamps do not come on	<ol style="list-style-type: none"> 1. Bypass plug is not installed, see <i>Electrical Connections</i>. 2. A non-SunStar® bypass has been used. See <i>Electrical Connections</i>. 3. If remote is being used, other than T-Max® Manager, the external timer may not be activated. 4. Remote wiring is incorrect, see the instructions provided with the remote interface kit.
My booth is connected to the T-Max® Manager remote system and when the delay time has expired the timer display starts counting down but the tanning lights do not come on	<p>The auto start feature of the remote system is disabled, see the instructions provided with your remote system.</p>
My unit won't work with the T-Max® Manager remote system	<ol style="list-style-type: none"> 1. The unit must first be set to a unique address, see <i>Remote Connections</i>. 2. The bypass or terminator plug may be installed in the series in an inappropriate location. Plug the bypass plug only into the unit at the end of the series.
Timer display continues to show a 0 after the timer button is pressed	<ol style="list-style-type: none"> 1. T-Max® Manager remote system has not yet been set. 2. Unit address is not set correctly, see <i>Remote Connections</i>.
The last minute of tanning time does not count down from 59 seconds, but some time less than 59 seconds	<p>If the timer button has been pressed to decrease tanning time during the session, the time expired in the current minute is subtracted from the last minute.</p>

Problem	Solution
My unit is connected to a T-Max® remote system but I am having trouble getting into “id” mode	You have probably attempted to connect your booth to the remote system already. Disconnect the remote plug(s) from the ports at the back of the booth, wait 90 seconds and try again.
My unit, connected to a T-Max® Manager, did not display “dL” but does indicate: “0” a tanning time and the lamps have come on a tanning time but the lamps have not come on	<ol style="list-style-type: none"> 1. Remote device has not been set. 2. The unit has not been connected to the remote system, see <i>Remote Connections</i>. <ol style="list-style-type: none"> 1. Delay time of T-Max® Manager has not been set. 2. Delay time has expired and session has begun. Auto start function of T-Max® Manager has been turned off. Press the timer button to turn on lamps.
When auto-addressing the first bed does not register an “id”	When using the auto address feature of the T-Max® Manager you must wait 10 seconds from the time you start the auto address function before addressing the first bed.
When using a T-Max® 1A my unit won't function properly	SunStar® Bypass plugs or terminator plugs may be needed if the T-Max® 1A and the unit are over 100 feet apart. Install the plugs in the open remote port in the unit and the T-Max® 1A.
I forgot what address, or “id”, I set my booth to	A little to the left of the Address Indicator is a hidden button (a small raised bump). By holding this button for 3 seconds the timer display will briefly display three numbers; the installed timer software version, a factory set timer code and then the equipment's “id” number.
Timer display is indicating Er 1	Body lamps are on when they should be off, have service technician check the contactor.
Timer display is indicating Er 2	Body lamps are off when they should be on, have service technician check contactor and its wiring from the main timer box.
Timer display is indicating Er 3	Bench lamps are on when they should be off, have service technician check the contactor. (Units with separate bench contactor only.)

<i>Problem</i>	<i>Solution</i>
Timer display is indicating Er 4	Bench lamps are off when they should be on, have service technician check the contactor and its wiring from the main timer box. (Units with separate bench contactor only.)
Timer display is indicating Er 5	Not currently used
Timer display is indicating Er 6	Not currently used
Timer display is indicating Er 7	Face Tanner contactor is closed when it should be open, have service technician check the contactor.
Timer display is indicating Er 8	Face Tanner contactor is open when it should be closed, have service technician check the contactor and its wiring from the main timer box.
Timer display is indicating Er 9	Ballast Drawer is open or drawer switch is broken.
Timer display is indicating Er 10	Timer computer is in an illegal state, reset power to correct, replace main timer if error reoccurs.
Timer display is indicating Er 11	Timer computer is in an illegal state, reset power to correct, replace main timer if error reoccurs.
Timer display is indicating Er 12	Timer computer is in an illegal state, reset power to correct, replace main timer if error reoccurs.
Timer display is indicating Er 13	Timer computer is in an illegal state, reset power to correct, replace main timer if error reoccurs.
Timer display is indicating Er 14	The timer display is not responding; 1. Check cable to display. 2. Replace display assembly. 3. Replace main timer box.
Timer display is indicating Er 15	Timer computer is in an illegal state, reset power to correct, replace main timer if error reoccurs.



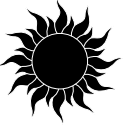

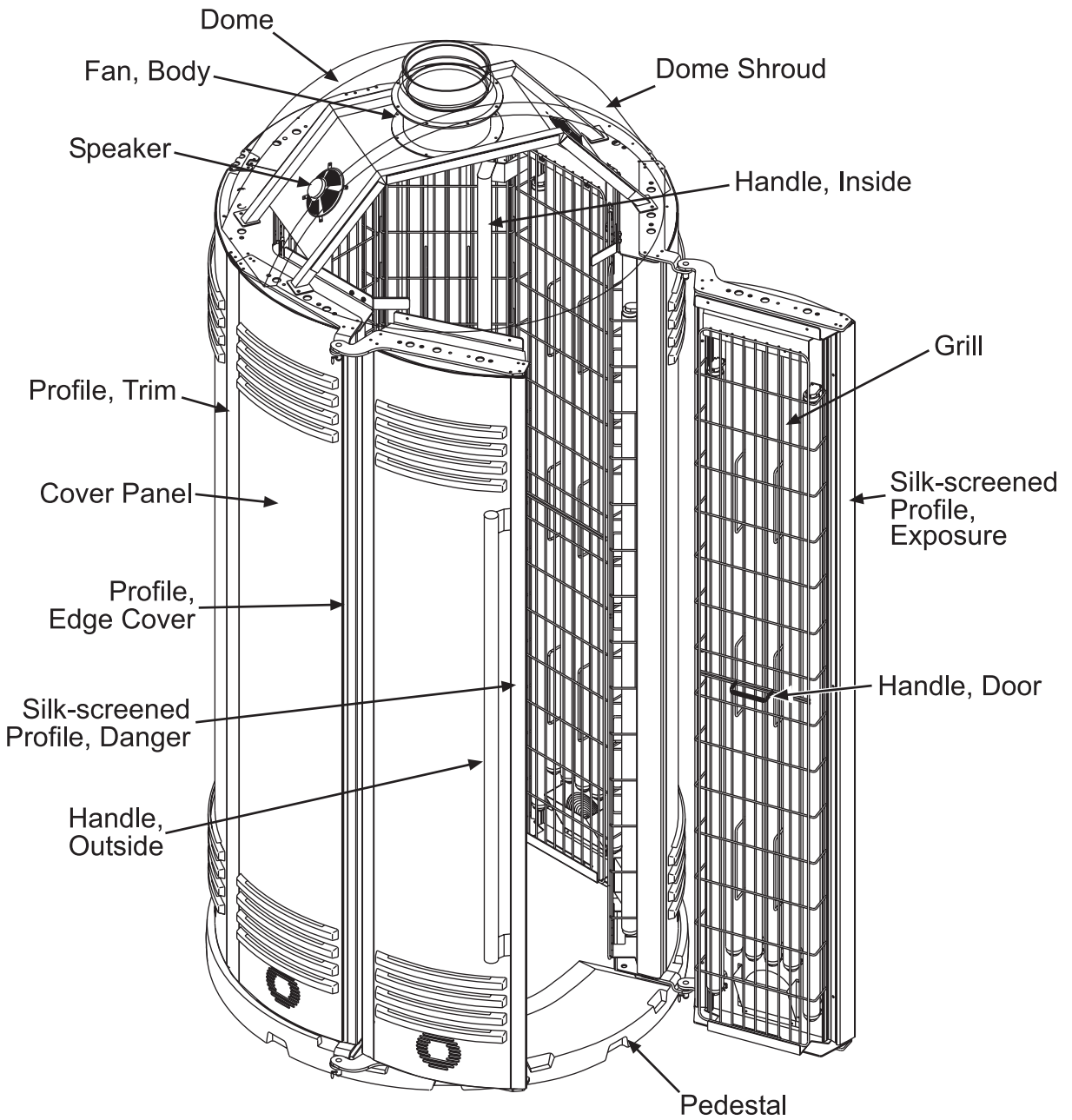

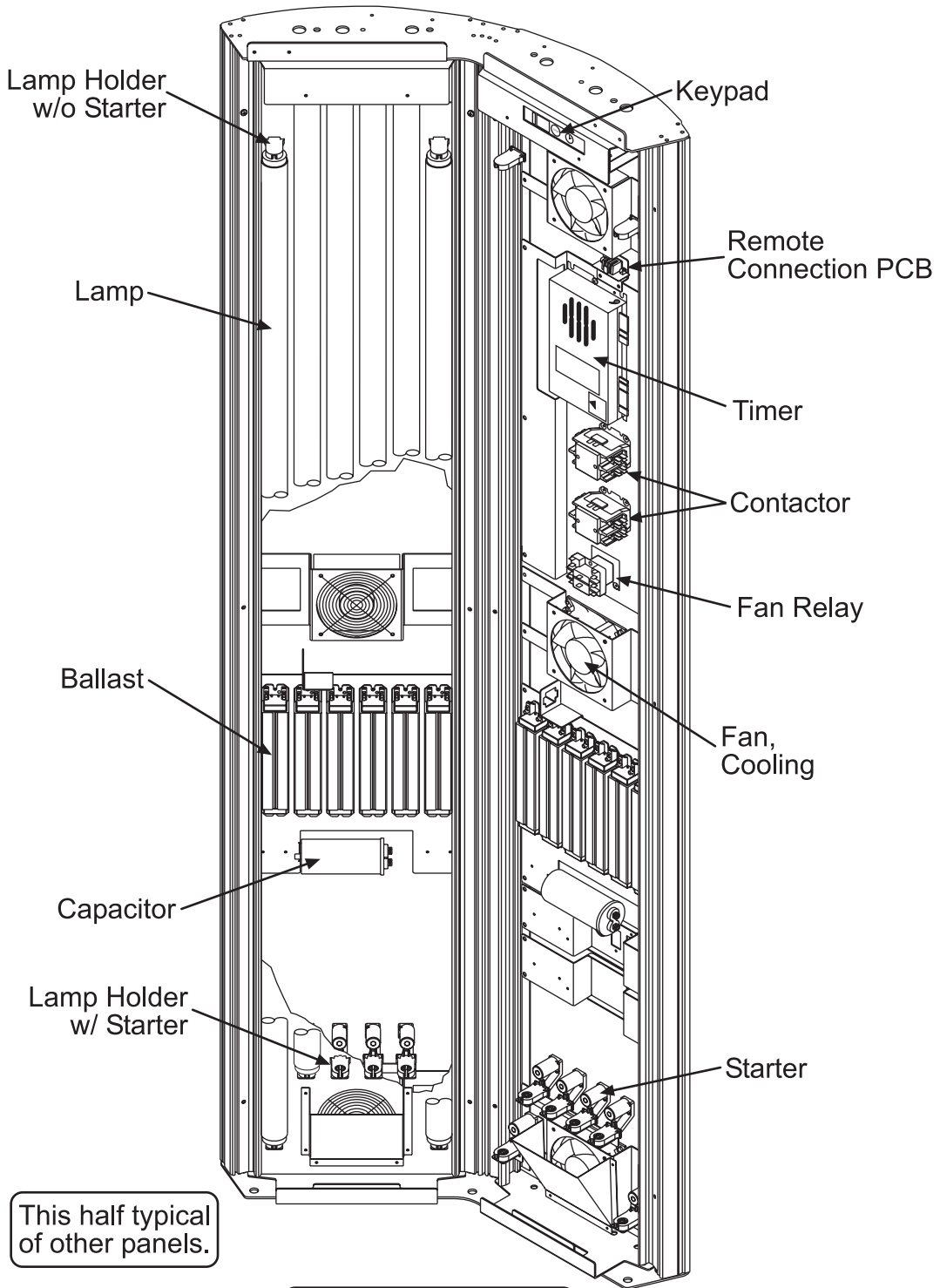

This half typical of other panels.

Control Module shown.

Parts List

(When calling for parts, first state your booth model as J-48 SUNDOME. Then refer to this list and illustrations for proper part identification.)

- | | |
|------------------------------------|--------------------------------------|
| Air Dam* (Foam inside cover panel) | Hour Counter* |
| Ballast, 160W | Lamp Holder w/ Starter |
| Bronze Hinge Bushing* | Lamp Holder w/o Starter |
| Capacitor, 75uF | Lamps |
| Contacto (Relay) | Manual* |
| Cover Panel | Pedestal |
| Cover Panel w/ Decal* | Profile, Edge Cover |
| Cover Panel w/ Power Cut-outs* | Profile, Trim |
| Dome (orange) | Remote Connection PCB |
| Dome Shroud (blue) | Remote Control Bypass Plug* |
| Fan, Body | Schematic Packet* |
| Fan, Cooling | Silk-screened Profile, Danger |
| Fan Relay | Silk-screened Profile, Exposure |
| Grill | Speaker (pair) |
| Handle, Door | Starter, K-12 |
| Handle, Inside | Timer |
| Handle, Outside | Wiring Harness, Keypad to Timer* |
| Hardware Kit* | Wiring Harness, Remote PCB to Timer* |
| Hinge Locking Pin* | |

* Not shown

Record this information for ease of service:

Date of purchase: _____

Serial number: _____

CALL FOR SERVICE OR QUESTIONS: 1•800•449•3605
ETS, Inc. 6270 Corporate Drive, Indianapolis, IN 46278-2900

**CALL FOR SERVICE OR
QUESTIONS:**

1•800•449•3605



**6270 Corporate Drive
Indianapolis, IN 46278-2900**

