

Hardware Reference Manual

for the



4-Channel New Generation and

8-Channel High-Speed Serial I/O Adapters

C²I² Systems Document No.	CCII/HSS8/6-MAN/001
Document Issue	1.8
Issue Date	2013-08-30
Print Date	2013-08-30
File Name	W:\HSS8\TECH\MAN\CH8MAN01.wpd
Distribution List No.	

© C²I² Systems *The copyright of this document is the property of C²I² Systems. The document is issued for the sole purpose for which it is supplied, on the express terms that it may not be copied in whole or part, used by or disclosed to others except as authorised in writing by C²I² Systems.*

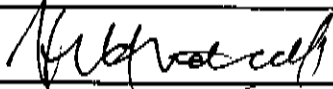
Signature Sheet

Name	Signature	Date
Completed by H METCALF	 Project Engineer Board Level Products C ² P Systems	2013-08-30
Accepted by W. DE LUCA	 Project Manager Board Level Products C ² P Systems	2013-08-30
Accepted by ITCH METCALF	 Quality Assurance C ² P Systems	2013-08-30

Amendment History

Issue	Description	Date	ECP No.
0.1	First Draft.	2004-02-20	-
0.2	Updated as per WRM and XK reviews.	2004-04-10	-
0.3	Added Front Panel Adapter.	2004-07-07	-
1.0	Baseline.	2004-07-14	-
1.1	Fixed pinouts for J1 connector.	2005-07-15	CCII/HSS8/6-ECP/020
1.2	Updated to include PCI and PCI-104 adapters. Added information on different versions of adapters.	2006-08-03	CCII/HSS8/6-ECP/023 CCII/HSS8/6-ECP/028
1.3	Add information on HSS4NG channels, RTS/CTS/CD usage.	2007-09-19	CCII/HSS8/6-ECP/032
1.4	Improve document naming consistency.	2009-07-09	CCII/HSS8/6-ECP/039
1.5	Updated to include pinout information for our FP3 PMC, PCI and PCI-104 Adapters.	2009-10-08	CCII/HSS8/6-ECP/045
1.6	Corrected the pin information relating to the Tyco connectors in the Tables.	2009-10-13	CCII/BLPGEN/6-ECP/020
1.7	Added RS-232 Loopback Cable diagram.	2012-02-10	CCII/BLPGEN/6-ECP/
1.8	Updated Part Numbers and Description of 50 way Tyco connector.	2013-08-30	CCII/HSS8/6-ECP/056

CCII/HSS8/6-MAN/001	2013-08-30	Issue 1.8
CH8MAN01.wpd		Page iii of viii

Contents

1.	Scope	1
1.1	Identification	1
1.3	Document Overview	2
2.	Applicable and Reference Documents	3
2.1	Applicable Documents	3
2.2	Reference Documents	3
3.	Architecture	4
3.1	Overview	4
3.2	Functional Block Diagram	4
3.3	PCI Interface	5
3.4	Processors	5
3.5	PCI Bridge	5
3.6	RAM	6
3.7	Flash Memory	6
3.8	EEPROM	6
3.10	SCC	6
3.11	Serial Management Controller (SMC)	7
3.12	Baud Rate Generators/Serial Clock Inputs	7
3.13	Serial I/O Interface	7
3.14	Transceivers	7
3.15	Termination Resistors	8
3.16	Handshaking Signals for SCC Channels in RS-232 mode	10
4.	Formfactors	11
4.1	PMC	11
4.2	Conduction-Cooled PMC	11
4.3	PCI-104	11
4.4	PCI	11
6.	Serial I/O Connectors	20
6.1	PMC I/O Connector	20
6.2	J1 (Molex) I/O Connector	22
6.3	J1 (Tyco) I/O Connector	25
6.4	J2 (Tyco) I/O Connector	27
6.5	J3 (Samtec) I/O Connector	29
6.6	J4 (Samtec) I/O Connector	30
6.7	J1 (Samtec) I/O Connector	31
6.8	Notes	32
Annexure A	33
Molex 120-Pin Connector	33
Annexure B	36
Tyco 50-Pin Connector	36
Annexure C	38
Samtec 20-Pin and 34-Pin Connector	38

CCII/HSS8/6-MAN/001	2013-08-30	Issue 1.8
CH8MAN01.wpd		Page iv of viii

List of Tables

<u>Table 1 :</u>	<u>Default PCI Configuration Space Values</u>	5
<u>Table 2 :</u>	<u>Function of Status Indicators</u>	6
<u>Table 3 :</u>	<u>JP2 Driver Mode Selection</u>	8
<u>Table 4 :</u>	<u>JP5 Configuration of Line Termination Resistors for Channels A - D for the PMC, PCI-104 and FP PCI Adapters</u>	8
<u>Table 5 :</u>	<u>Connector Information for Line Termination Resistors for Channels A - D for the FP 3 PCI Adapters</u>	9
<u>Table 6 :</u>	<u>JP6 Configuration of Line Termination Resistors for Channels E - H for the PMC, PCI-104 and FP PCI Adapters (Not available on HSS4NG)</u>	9
<u>Table 7 :</u>	<u>Connector Information for Line Termination Resistors for Channels E - H for the FP3 PCI Adapter (Not available on HSS4NG)</u>	10
<u>Table 8 :</u>	<u>SCC Signal Pins on the Pn4 Connector for CCPMC Adapters</u>	20
<u>Table 9 :</u>	<u>SCC Signal Pins on the Pn4 Connector for CCPMC Adapters (Not available on HSS4NG)</u>	21
<u>Table 10 :</u>	<u>SCC Signal Pins on J1 Connector for FP1 Adapters</u>	22
<u>Table 11 :</u>	<u>SCC Signals Pins on J1 Connector for FP1 Adapters (Not available on HSS4NG)</u>	23
<u>Table 12 :</u>	<u>SMC Signal Pins on J1 Connector for FP1 Adapters</u>	23
<u>Table 13 :</u>	<u>LED Signal Pins on J1 Connector for FP1 Adapters</u>	24
<u>Table 14 :</u>	<u>Ground Signal Pins on J1 Connector for FP1 Adapters</u>	24
<u>Table 15 :</u>	<u>SCC Signal Pins on J1 Connector for the PMC and PCI FP3 Adapters</u>	25
<u>Table 16 :</u>	<u>SMC Signal Pins on J1 Connector for the PMC and PCI FP3 Adapters</u>	25
<u>Table 17 :</u>	<u>LED Signal Pins on J1 Connector for the PMC and PCI FP3 Adapters</u>	26
<u>Table 18 :</u>	<u>Ground Signal Pins on J1 Connector for the PMC and PCI FP3 Adapters</u>	26
<u>Table 19 :</u>	<u>SCC Signal Pins on J2 Connector for the PMC and PCI FP3 Adapters (Not available on HSS4NG)</u>	27
<u>Table 20 :</u>	<u>SMC Signal Pins on J2 Connector for the PMC and PCI FP3 Adapters (Not available on HSS4NG)</u>	27
<u>Table 21 :</u>	<u>LED Signal Pins on J2 Connector for the PMC and PCI FP3 Adapters (Not available on HSS4NG)</u>	28
<u>Table 22 :</u>	<u>Ground Signal Pins on J2 Connector for the PMC and PCI FP3 Adapters</u>	28
<u>Table 23 :</u>	<u>SCC Signal Pins on J3 Connector for the PCI-104 FP3 Adapters</u>	29
<u>Table 24 :</u>	<u>Ground Signal Pins on J3 Connector for the PCI-104 FP3 Adapters</u>	29
<u>Table 25 :</u>	<u>SCC Signal Pins on J4 Connector for the PCI-104 FP3 Adapters (Not available on HSS4NG)</u>	30
<u>Table 26 :</u>	<u>Ground Signal Pins on J4 Connector for the PCI-104 FP3 Adapters</u>	30

CCII/HSS8/6-MAN/001	2013-08-30	Issue 1.8
CH8MAN01.wpd		Page v of viii

Table 27 : SMC AND LED Signal Pins on J1 Connector for the PC-104 FP3 Adapters 31

Table 28 : Ground Signal Pins on J4 Connector for the PCI-104 FP3 Adapters 31

CCII/HSS8/6-MAN/001	2013-08-30	Issue 1.8
CH8MAN01.wpd		Page vi of viii

List of Figures

<u>Figure 1 : Functional Block Diagram of the HSS8 Adapter</u>	4
<u>Figure 2 : Connector Locations on the HSS8 CCPMC and HSS4NG Adapters (Mod 0)</u>	12
<u>Figure 3 : Connector Locations on the HSS8 CCPMC and HSS4NG Adapters (Mod 1 and above)</u>	13
<u>Figure 4 : Connector Locations on the HSS8 PMC and HSS4NG Adapters (FP)</u>	14
<u>Figure 5 : Connector Locations on the HSS8 PMC and HSS4NG Adapters (FP1)</u>	15
<u>Figure 6 : Connector Locations on the HSS8 PMC and HSS4NG PMC Adapters (FP3)</u>	16
<u>Figure 7 : Connector Locations on the HSS8 PCI and HSS4NG PCI Adapters (FP)</u>	17
<u>Figure 8 : Connector Locations for the HSS8 PCI and HSS4NG PCI Adapters (FP3)</u>	17
<u>Figure 9 : Connector Locations on the HSS8 PCI-104 and HSS4NG PCI-104 Adapters (FP)</u>	18
<u>Figure 10 : Connector Locations on HSS8 PCI-104 and HSS4NG PCI-104 Adapters (FP3)</u>	19
<u>Figure 12 : Molex 120-Pin PCB Connector</u>	33
<u>Figure 13 : Molex 120-Pin PCB Connector (Expanded View)</u>	34
<u>Figure 14 : Tyco 50-Pin PCB Connector</u>	36
<u>Figure 17 : Samtec 20-Pin and 34-Pin PCB Connector</u>	38

CCII/HSS8/6-MAN/001	2013-08-30	Issue 1.8
CH8MAN01.wpd		Page vii of viii

Abbreviations and Acronyms

BiSync	Binary Synchronous Communication
BRG	Baud Rate Generator
CCPMC	Conduction-Cooled Peripheral Component Interconnect Mezzanine Card
CD	Carrier Detect
CMC	Common Mezzanine Card
CRC	Cyclic Redundancy Check
CTS	Clear to Send
EEPROM	Electrically Erasable Programmable Read Only Memory
HCC	Host Carrier Card
HDLC	High Level Data Link Control
HSS	High-Speed Serial
HSS4NG	4-Channel New Generation High-Speed Serial I/O Adapter
HSS8	8-Channel High-Speed Serial I/O Adapter
I/O	Input/Output
ID	Identification
JTAG/COP	Joint Test Action Group/Common On-Chip Processor
kbit/s	kilobits per second
LAN	Local Area Network
LED	Light Emitting Diode
PCI	Peripheral Component Interconnect
PMC	Peripheral Component Interconnect Mezzanine Card
POST	Power-On Self Test
PPP	Point to Point Protocol
QUICC	Quad Integrated Communications Controller
RAM	Random Access Memory
RTS	Request to Send
SCC	Serial Communication Controller
SDLC	Synchronous Data Link Control
SMC	Serial Management Controller
UART	Universal Asynchronous Receiver/Transmitter

CCII/HSS8/6-MAN/001	2013-08-30	Issue 1.8
CH8MAN01.wpd		Page viii of viii

1. Scope

1.1 Identification

This document is the technical reference manual for the C²I² Systems 8-Channel High-Speed Serial I/O (HSS) Adapter, hereinafter named the HSS8 Adapter. It also applies to the 4-Channel New Generation HSS (HSS4NG) Adapter. Unless otherwise specified, all references to HSS8 also apply to HSS4NG.

1.2 System Overview

The HSS8 Adapter provides eight channels of simultaneous, High-Speed, bi-directional serial communications and an additional four lower-speed RS-232 channels (not available on all versions). The eight High-Speed channels are configurable (on a per channel basis) for RS-232 or RS-422/485 drivers while the lower-speed channels have RS-232 drivers only.

The HSS8 Adapter is currently available in PMC, Conduction-Cooled PMC (CCPMC), PCI-104 and PCI formfactors.

By omitting some components during manufacture, this adapter can also be built as a 4-Channel Adapter, which is known as the 4-Channel New Generation High-Speed Serial I/O Adapter (HSS4NG).

Applicable Part Numbers are :

8-Channel HSS (HSS8) :

CCII/SIO/PMC/8P/FP/COM	Commercial Grade, 3,3 V PCI interface, PMC Formfactor
CCII/SIO/PMC/8P/FP/IND	Industrial Grade, 3,3 V PCI interface, PMC Formfactor
CCII/SIO/PMC/8P/FP/RGD	Ruggedised, 3,3 V PCI interface, PMC Formfactor
CCII/SIO/PMC/8P/FP1/COM	Commercial Grade, 5 V tolerant PCI interface, PMC Formfactor
CCII/SIO/PMC/8P/FP1/IND	Industrial Grade, 5 V tolerant PCI interface, PMC Formfactor
CCII/SIO/PMC/8P/FP1/RGD	Ruggedised, 5 V tolerant PCI interface, PMC Formfactor
CCII/SIO/PMC/8P/FP3/COM	Commercial Grade, 5 V tolerant PCI interface, PMC Formfactor
CCII/SIO/PMC/8P/FP3/IND	Industrial Grade, 5 V tolerant PCI interface, PMC Formfactor
CCII/SIO/PMC/8P/FP3/RGD	Ruggedised, 5 V tolerant PCI interface, PMC Formfactor
CCII/SIO/PMC/8P/BP/CC	Conduction-Cooled, 3,3 V PCI interface, CCPMC Formfactor
CCII/SIO/PCI/8P/FP/COM	Commercial Grade, 3,3 V PCI interface, PCI Formfactor
CCII/SIO/PCI/8P/FP/IND	Industrial Grade, 3,3 V PCI interface, PCI Formfactor
CCII/SIO/PCI/8P/FP3/COM	Commercial Grade, 5 V tolerant PCI interface, PCI Formfactor
CCII/SIO/PCI/8P/FP3/IND	Industrial Grade, 5 V tolerant PCI interface, PCI Formfactor
CCII/SIO/PC104/8P/FP/COM	Commercial Grade, 3,3 V PCI interface, PCI-104 Formfactor
CCII/SIO/PC104/8P/FP/IND	Industrial Grade, 3,3 V PCI interface, PCI-104 Formfactor
CCII/SIO/PC104/8P/FP/RGD	Ruggedised, 3,3 V PCI interface, PCI-104 Formfactor
CCII/SIO/PC104/8P/FP3/COM	Commercial Grade, 3,3 V PCI interface, PCI-104 Formfactor
CCII/SIO/PC104/8P/FP3/IND	Industrial Grade, 3,3 V PCI interface, PCI-104 Formfactor
CCII/SIO/PC104/8P/FP3/RGD	Ruggedised, 3,3 V PCI interface, PCI-104 Formfactor

4-Channel HSS (HSS4NG) :

CCII/SIO/PMC/4PN/FP/COM	Commercial Grade, 3,3 V PCI interface, PMC Formfactor
CCII/SIO/PMC/4PN/FP/IND	Industrial Grade, 3,3 V PCI interface, PMC Formfactor
CCII/SIO/PMC/4PN/FP/RGD	Ruggedised, 3,3 V PCI interface, PMC Formfactor
CCII/SIO/PMC/4PN/FP1/COM	Commercial Grade, 5 V tolerant PCI interface, PMC Formfactor
CCII/SIO/PMC/4PN/FP1/IND	Industrial Grade, 5 V tolerant PCI interface, PMC Formfactor
CCII/SIO/PMC/4PN/FP1/RGD	Ruggedised, 5 V tolerant PCI interface, PMC Formfactor
CCII/SIO/PMC/4PN/FP3/COM	Commercial Grade, 5 V tolerant PCI interface, PMC Formfactor
CCII/SIO/PMC/4PN/FP3/IND	Industrial Grade, 5 V tolerant PCI interface, PMC Formfactor
CCII/SIO/PMC/4PN/FP3/RGD	Ruggedised, 5 V tolerant PCI interface, PMC Formfactor
CCII/SIO/PMC/4PN/BP/CC	Conduction-Cooled, 3,3 V PCI interface, CCPMC Formfactor

CCII/HSS8/6-MAN/001	2013-08-30	Issue 1.8
CH8MAN01.wpd		Page 1 of 39

CCII/SIO/PCI/4PN/FP/COM	Commercial Grade, 3,3 V PCI interface, PCI Formfactor
CCII/SIO/PCI/4PN/FP/IND	Industrial Grade, 3,3 V PCI interface, PCI Formfactor
CCII/SIO/PCI/4PN/FP3/COM	Commercial Grade, 5 V tolerant PCI interface, PCI Formfactor
CCII/SIO/PCI/4PN/FP3/IND	Industrial Grade, 5 V tolerant PCI interface, PCI Formfactor
CCII/SIO/PC104/4PN/FP/COM	Commercial Grade, 3,3 V PCI interface, PCI-104 Formfactor
CCII/SIO/PC104/4PN/FP/IND	Industrial Grade, 3,3 V PCI interface, PCI-104 Formfactor
CCII/SIO/PC104/4PN/FP/RGD	Ruggedised, 3,3 V PCI interface, PCI-104 Formfactor
CCII/SIO/PC104/4PN/FP3/COM	Commercial Grade, 3,3 V PCI interface, PCI-104 Formfactor
CCII/SIO/PC104/4PN/FP3/IND	Industrial Grade, 3,3 V PCI interface, PCI-104 Formfactor
CCII/SIO/PC104/4PN/FP3/RGD	Ruggedised, 3,3 V PCI interface, PCI-104 Formfactor

1.3 Document Overview

This document describes the functional building blocks of the HSS8 Adapter. It serves as a reference for the jumper settings and connector pinouts. It also explains the differences between the various formfactors in which the HSS8 and HSS4NG Adapters are available as products. For programming the adapter, please also refer to the User Manual for the relevant Software Driver, as listed in Paragraph 2.2.

CCII/HSS8/6-MAN/001	2013-08-30	Issue 1.8
CH8MAN01.wpd		Page 2 of 39

2. **Applicable and Reference Documents**

2.1 Applicable Documents

- 2.1.1 IEEE Std 1386-2001, *IEEE Standard for a Common Mezzanine Card (CMC) Family*, dated 2001-06-14.
- 2.1.2 PCI Special Interest Group, *PCI Local Bus Specification*, Rev. 2.2, dated 1998-12-18.
- 2.1.3 *MPC8260 PowerQUICC II Family Reference Manual*, MPC8260UM/D Rev. 1, dated May 2003.
- 2.1.4 ANSI/Vita Std 20-2001, *American National Standard for Conduction Cooled PMC*, dated 2001-08-31.

2.2 Reference Documents

- 2.2.1 C²I² Systems document CCII/HSS/6-MAN/002, titled *User Manual for the 8-Channel and 4-Channel High-Speed Serial VxWorks Software Driver*, issue 1.3, dated 2008-01-28.
- 2.2.2 C²I² Systems document CCII/HSS/6-MAN/003, titled *User Manual for the 8-Channel and 4-Channel High-Speed Serial Linux Software Driver*, issue 1.1, dated 2006-06-29.
- 2.2.3 C²I² Systems document CCII/HSS/6-MAN/004, titled *User Manual for the 8-Channel and 4-Channel High-Speed Serial Windows NT 4 Software Driver*, issue 1.1, dated 2006-06-29.
- 2.2.4 C²I² Systems document CCII/BLPGEN/6-MAN/004, titled *Assembly Procedure for Serial I/O Cable Assembly*, issue 0.2, dated 2009-06-11.
- 2.2.5 C²I² Systems document CCII/BLPGEN/6-MAN/003, titled *Assembly Procedure for Partial Cable Assembly*, issue 1.0, dated 2009-06-11.

CCII/HSS8/6-MAN/001	2013-08-30	Issue 1.8
CH8MAN01.wpd		Page 3 of 39

3. Architecture

3.1 Overview

The HSS8 Adapter provides eight channels of simultaneous, High-Speed, bi-directional Serial I/O communications. Each channel is capable of running in RS-232 or RS-422/485 mode. In addition, some HSS8 Adapters provide an additional four lower-speed RS-232 channels (refer to Paragraph 4).

The HSS4NG Adapter provides four High-Speed channels, as well as two lower-speed RS-232 channels in some instances.

3.2 Functional Block Diagram

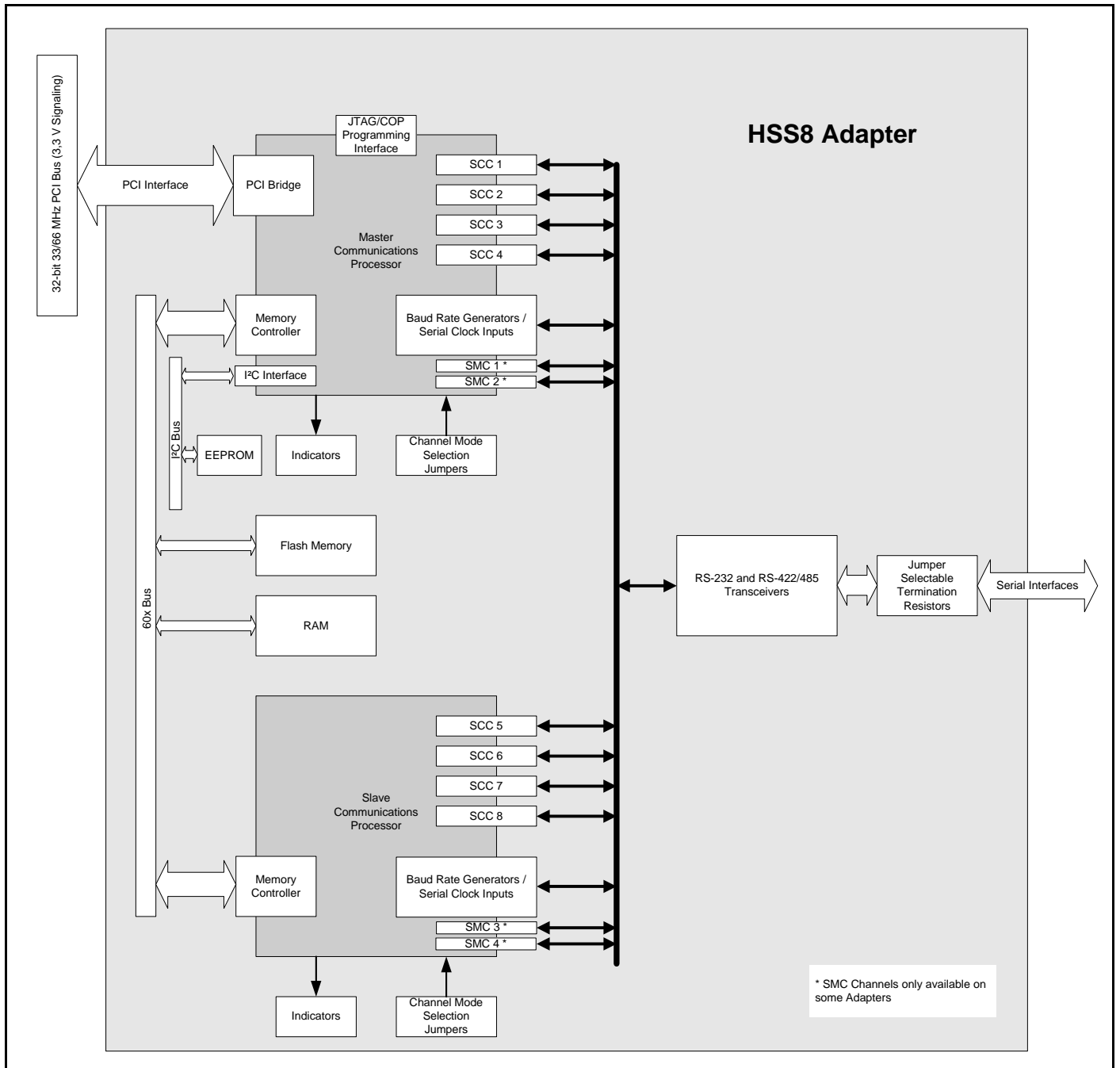

Figure 1 : Functional Block Diagram of the HSS8 Adapter

CCII/HSS8/6-MAN/001	2013-08-30	Issue 1.8
CH8MAN01.wpd		Page 4 of 39

The HSS8 Adapter consists of the following functional elements :

- PCI Interface (32-bit, 33/66 MHz)
- Two Processors (PowerQUICC II)
- PCI Bridge (internal to the Master processor)
- RAM (4 MBytes)
- Flash memory (2 MBytes)
- EEPROM (I²C Serial - 128 Bytes)
- Indicators (for monitoring health and activity)
- Eight Serial I/O Communication Controllers (SCCs)
- Four Serial I/O Management Controllers (SMCs)
- Eight Baud Rate Generators (BRG) and eight external serial clock inputs
- RS-232 and RS-422/485 Transceivers (Jumper Selectable)
- Termination Resistors (100 Ω for RS-422/485 - Jumper Selectable)

The HSS4NG Adapter is a special build which omits some devices to provide four High-Speed channels and not eight. Specifically, the Slave PowerQUICC II Communications Processor and associated line drivers are not present.

3.3 PCI Interface

The PCI interface allows the HSS8 Adapter to be fitted on any Host Carrier Card (HCC) conforming to the PCI specification and supporting 3.3 V PCI signalling. This includes PMC and PCI-104 HCCs. Some versions of the HSS8 Adapters are also 5 V PCI compatible, please refer to the specifications. For Conduction-Cooled PMC HCCs, the Serial I/O interfaces of the HSS8 Adapter are routed through the PMC connector Pn4 [refer to Figure 2 or Figure 3].

The HSS8 Adapter will automatically detect the clock speed of the PCI bus (either 33 MHz or 66 MHz) and configure itself to operate at the correct frequency.

Refer to the PCI Specification [2.1.2] for a complete description of the PCI interface signals and to the CMC Specification [2.1.1] for information on busmode signalling for PMC adapters.

3.4 Processors

The HSS8 Adapter incorporates two PowerQUICC II Communications Processors to provide a total of eight (four per processor) High-Speed Serial I/O channels with protocol processing. The PowerQUICC II Communications Processors each have a built-in memory controller for connection to static Random Access Memory (RAM) and Flash memory. For serial clock generation, a total of eight (four per processor) built-in Baud Rate Generators (BRGs) are provided and provision is made for eight external serial clock inputs.

Refer to the PowerQUICC II Reference Manual [2.1.3] for more information.

CCII/HSS8/6-MAN/001	2013-08-30	Issue 1.8
CH8MAN01.wpd		Page 5 of 39

3.5 PCI Bridge

The PCI bridge translates memory access requests on the PCI bus to requests on the local bus and vice versa. The HSS8 Adapter uses the integrated PCI bridge of the PowerQUICC II Communications Processor to interface to the PCI bus. Table 1 specifies the default configuration space values used by the HSS8 Adapter.

Offset	Default Value	Description
0x00	0x1057	<i>Vendor Identifier</i>
0x02	0x18C0	<i>Device Identifier</i>
0x10	--	<i>Base Address of HSS8 Adapter assigned by HCC</i>

Table 1 : Default PCI Configuration Space Values

Refer to the PowerQUICC II Reference Manual [2.1.3] for more information.

3.6 RAM

The HSS8 Adapter incorporates 4 MBytes of static RAM. This memory is used at run-time for processing interrupts and for passing control information to and from the HCC.

3.7 Flash Memory

The HSS8 Adapter incorporates 2 MBytes of programmable Flash memory. The Flash memory is used as a boot device and holds the adapter's firmware. Furthermore, it holds the PCI configuration information. The firmware is initially programmed using the Joint Test Action Group/Common On-Chip Processor (JTAG/COP) interface (JP4), but can subsequently be upgraded from the HCC over the PCI bus.

3.8 EEPROM

The HSS8 Adapter incorporates a 128 Byte I²C Serial EEPROM. The EEPROM is used to store Power-On Self Test (POST) information as well as the version number of the adapter. The EEPROM is programmed from the HCC over the PCI bus.

3.9 Indicators

The HSS8 Adapter provides indicators for reporting both hardware and software status. Refer to Figures 2 to 9 for indicator locations. The function of each indicator is as per Table 2.

Indicator	Description
LD1	Alive (Heartbeat) & POST Status during boot up cycle
LD2	TX (Activity on Channels A - H) & POST Status during boot-up cycle
LD3	RX (Activity on Channels A - H) & POST Status during boot-up cycle
LD7	3,3 V Power Good Indicator
LD8	Unused

Table 2 : Function of Status Indicators

Some HSS8 Adapters allows the user to connect external Light Emitting Diode (LEDs) via J1.

CCII/HSS8/6-MAN/001	2013-08-30	Issue 1.8
CH8MAN01.wpd		Page 6 of 39

3.10 SCC

The HSS8 Adapter provides eight High-Speed SCC channels enabling it to support a large number of serial protocols. The following serial protocols are supported :

- High Level Data Link Control (HDLC) / Synchronous Data Link Control (SDLC)
- HDLC bus (implements an HDLC-based local area network (LAN))
- Asynchronous HDLC to support Point-to-Point Protocol (PPP)
- AppleTalk
- Universal Asynchronous Receiver/Transmitter (UART)
- Synchronous UART
- Binary Synchronous Communication (BiSync)
- Totally Transparent (bit streams)
- Totally Transparent (frame based with optional Cyclic Redundancy Check (CRC))

SCC channels can be jumper configured to operate in RS-232 and/or RS-422/485 modes. Some limitations apply, see Paragraph 3.14.

CCII/HSS8/6-MAN/001	2013-08-30	Issue 1.8
CH8MAN01.wpd		Page 7 of 39

3.11 Serial Management Controller (SMC)

Some adapters provides two or four SMC channels in addition to the SCCs. The SMCs support the following :

- UART - RS-232 only

Refer to Paragraph 6.2.

3.12 Baud Rate Generators/Serial Clock Inputs

The HSS8 Adapter has eight independent baud rate generators (BRG) that may be set to any valid baud rate.

The equation to calculate the actual baud rate for *asynchronous* protocols is as follows :

$$\text{Actual Baud Rate} = 100 \text{ MHz} / 16 / \text{ROUND}(100 \text{ MHz} / 16 / \text{Desired Baud Rate})$$

The equation to calculate the actual baud rate for *synchronous* protocols is as follows :

$$\text{Actual Baud Rate} = 100 \text{ MHz} / \text{ROUND}(100 \text{ MHz} / \text{Desired Baud Rate})$$

Where ROUND() implies that the result is rounded to the nearest integer. For example, if the desired baud rate for asynchronous protocols is 57,6 kbit/s then :

$$\text{Actual Baud Rate} = 100\,000\,000 / 16 / (\text{ROUND}(100\,000\,000 / 16 / 57\,600)) = 57,339 \text{ kbit/s}$$

The baud rate of 57,339 kbit/s is within 2,5 % of the original baud rate (0,45 %). The 2,5 % margin is derived as follows : sending one character (including the start and stop bit) requires 10 bits. The receiver needs to sample each bit. Sampling happens in the middle of each bit. Hence, the sampler may not drift by more than ½ a bit, otherwise it will not sample the correct bit. More conservatively, the sampler should not be allowed to drift by more than ¼ bit (2,5 %).

The HSS8 Adapter also allows for eight serial clock inputs, allowing the user to supply custom clock rates to any of the SCCs. Clock division does not limit these input clocks, but their maximum values are dependent on the electrical interface as well as the protocols chosen. Refer to [2.1.3] for protocol limitations.

3.13 Serial I/O Interface

The Conduction-Cooled HSS8 PMC Adapter communicates with the user through rear I/O, using the Pn4 connector on the PMC [refer to Figures 2 and 3]. The pinouts and signal descriptions are provided in Paragraph 6.1.

Other HSS8 Adapters communicate with the user through frontpanel I/O, using Molex connector (J1) on our FP and FP1 Adapters, whereas on our PMC and PCI FP3 Adapters, communication takes place through 2 Tyco connectors, J1 and J2. On the FP3 PCI-104 Adapters, communication takes place through 3 headers. The pinouts and signal descriptions for all these signals are given in Paragraph 6.2 through to Paragraph 6.7, 6.8.

3.14 Transceivers

The HSS8 Adapter supports RS-232 and RS-422/485 electrical interfaces on each SCC channel. Mode selection is done via the Driver Mode Selection Jumper JP2 [refer to Table 3].

The PCI-104 range of adapters support RS-232 as well as RS-422/485 on SCC Channels A and B. All other SCC channels are RS-422/485 only.

CCII/HSS8/6-MAN/001	2013-08-30	Issue 1.8
CH8MAN01.wpd		Page 8 of 39

Table 3 shows how to select the driver mode for each SCC channel.

The SMC channels support RS-232 electrical interfaces only.

Channel	Pins on JP2	Mode	
		Open	Closed
A	1, 2	RS-232	RS-422/485
B	3, 4	RS-232	RS-422/485
C	5, 6	RS-232	RS-422/485
D	7, 8	RS-232	RS-422/485
E (Not available on HSS4NG)	9, 10	RS-232	RS-422/485
F (Not available on HSS4NG)	11, 12	RS-232	RS-422/485
G (Not available on HSS4NG)	13, 14	RS-232	RS-422/485
H (Not available on HSS4NG)	15, 16	RS-232	RS-422/485

Table 3 : JP2 Driver Mode Selection

Caution : RS-232 and RS-422/485 transceivers are multiplexed onto the same signal paths. The RS-422/485 transceivers are guaranteed to operate to a maximum transmit and receive voltage of -8 V to +13 V. While the RS-232 specification permits voltage levels exceeding the maximum rating of the RS-422/485 transceivers, most RS-232 transceivers operate well within tolerance of the RS-422/485 transceivers. Should the interfacing equipment used with this device, have transceivers that exceed the operating tolerances of the RS-422/485 transceivers, it is suggested that a special build of the HSS8 Adapter (without the RS-422/485 transceivers) be used.

3.15 Termination Resistors

100 Ω line termination resistors, required for RS-422/485, are switchable via jumpers for each channel. These resistors have a power rating of 200 mW, which should not be exceeded.

Termination resistors for Channels A - D and Channels E - H are configured by JP5 and JP6 respectively on our PMC, PCI - 104 and FP PCI Adapters, whereas on our FP3 PCI Adapters, these are configured by connectors JP1, JP3 and JP5 - JP18. Table 4, Table 5, Table 6 and Table 7 indicate how to configure the line termination resistors for Channels A - D and E - H respectively.

Channel	RS-422/485 Signals Terminated	Pins on JP5	Termination	
			Open	Closed
A	A_RxD+, A_RxD-	1, 2	-	100 Ω
A	A_CLK_IN+, A_CLK_IN-	3, 4	-	100 Ω
B	B_RxD+, B_RxD-	5, 6	-	100 Ω
B	B_CLK_IN+, B_CLK_IN-	7, 8	-	100 Ω
C	C_RxD+, C_RxD-	9, 10	-	100 Ω
C	C_CLK_IN+, C_CLK_IN-	11, 12	-	100 Ω
D	D_RxD+, D_RxD-	13, 14	-	100 Ω
D	D_CLK_IN+, D_CLK_IN-	15, 16	-	100 Ω

Table 4 : JP5 Configuration of Line Termination Resistors for Channels A - D for the PMC, PCI-104 and FP PCI Adapters

CCII/HSS8/6-MAN/001	2013-08-30	Issue 1.8
CH8MAN01.wpd		Page 9 of 39

Channel	RS-422/485 Signals Terminated	Connector Reference Designator	Termination	
			Open	Closed
A	A_RxD+, A_RxD-	JP1	-	100 Ω
A	A_CLK_IN+, A_CLK_IN-	JP3	-	100 Ω
B	B_RxD+, B_RxD-	JP5	-	100 Ω
B	B_CLK_IN+, B_CLK_IN-	JP6	-	100 Ω
C	C_RxD+, C_RxD-	JP7	-	100 Ω
C	C_CLK_IN+, C_CLK_IN-	JP8	-	100 Ω
D	D_RxD+, D_RxD-	JP9	-	100 Ω
D	D_CLK_IN+, D_CLK_IN-	JP10	-	100 Ω

Table 5 : Connector Information for Line Termination Resistors for Channels A - D for the FP 3 PCI Adapters

Channel	RS-422/485 Signals Terminated	Pins on JP6	Termination	
			Open	Closed
E	E_RxD+, E_RxD-	1, 2	-	100 Ω
E	E_CLK_IN+, E_CLK_IN-	3, 4	-	100 Ω
F	F_RxD+, F_RxD-	5, 6	-	100 Ω
F	F_CLK_IN+, F_CLK_IN-	7, 8	-	100 Ω
G	G_RxD+, G_RxD-	9, 10	-	100 Ω
G	G_CLK_IN+, G_CLK_IN-	11, 12	-	100 Ω
H	H_RxD+, H_RxD-	13, 14	-	100 Ω
H	H_CLK_IN+, H_CLK_IN-	15, 16	-	100 Ω

Table 6 : JP6 Configuration of Line Termination Resistors for Channels E - H for the PMC, PCI-104 and FP PCI Adapters (Not available on HSS4NG)

Channel	RS-422/485 Signals Terminated	Connector Reference Designator	Termination	
			Open	Closed
E	E_RxD+, E_RxD-	JP11	-	100 Ω
E	E_CLK_IN+, E_CLK_IN-	JP12	-	100 Ω
F	F_RxD+, F_RxD-	JP13	-	100 Ω
F	F_CLK_IN+, F_CLK_IN-	JP14	-	100 Ω
G	G_RxD+, G_RxD-	JP15	-	100 Ω
G	G_CLK_IN+, G_CLK_IN-	JP16	-	100 Ω
H	H_RxD+, H_RxD-	JP17	-	100 Ω
H	H_CLK_IN+, H_CLK_IN-	JP18	-	100 Ω

Table 7 : Connector Information for Line Termination Resistors for Channels E - H for the FP3 PCI Adapter (Not available on HSS4NG)

Caution : Line termination switches should be open when RS-232 mode is selected on a specific channel.

3.16 Handshaking Signals for SCC Channels in RS-232 mode

The handshake signals Request to Send (RTS), Clear to Send (CTS) and Carrier Detect (CD) are available for the SCC channels when in RS-232 mode.

It is important to note that the RTS and CTS signals relate to the transmit circuit while CD relates to the receive circuit.

In general it is recommended that CD is grounded, unless a requirement exists to gate the receiver.

4. Formfactors

HSS8 Adapters are available in PMC, Conduction-Cooled PMC, PCI-104 and PCI formfactors. Different formfactors have different features and capabilities as follows :

4.1 PMC

CCII/SIO/PMC/8P/FP	3,3 V PCI signalling only (not 5 V tolerant)	8 x SCC, 4 x SMC
CCII/SIO/PMC/8P/FP1	3,3 V or 5 V PCI signalling (5 V tolerant)	8 x SCC, 4 x SMC
CCII/SIO/PMC/8P/FP3	3,3 V or 5 V PCI signalling (5 V tolerant)	8 x SCC, 4 x SMC
CCII/SIO/PMC/4PN/FP	3,3 V PCI signalling only (not 5 V tolerant)	4 x SCC, 2 x SMC
CCII/SIO/PMC/4PN/FP1	3,3 V or 5 V PCI signalling (5 V tolerant)	4 x SCC, 2 x SMC
CCII/SIO/PMC/4PN/FP3	3,3 V or 5 V PCI signalling (5 V tolerant)	4 x SCC, 2 x SMC

Due to space constraints, the PMC voltage keying holes are not present on PMC adapters.

On CCII/SIO/PMC/8P/FP1 Mod 0 Adapters, the first four channels (Channels A to D) do not support RS-232.

4.2 Conduction-Cooled PMC

CCII/SIO/PMC/8P/BP/CC, Mod 0	3,3 V PCI signalling only (not 5 V tolerant)	8 x SCC
CCII/SIO/PMC/8P/BP/CC, Mod 1	3,3 V PCI signalling only (not 5 V tolerant)	8 x SCC
CCII/SIO/PMC/4PN/BP/CC, Mod 0	3,3 V PCI signalling only (not 5 V tolerant)	4 x SCC
CCII/SIO/PMC/4PN/BP/CC, Mod 1	3,3 V PCI signalling only (not 5 V tolerant)	4 x SCC

There are two models of the Conduction-Cooled PMC, namely Mod Level 0 and Mod Levels 1 and above. The jumper locations of these two Mod Levels are different, refer to Figures 2 and 3.

Due to the 64-pin I/O limitation, CCPMC adapters support only the SCC channels by default. Mod Level 1 and above are also available in special builds where the SMC channels are available at the expense of receive and transmit clock signals. Please enquire for more information.

Due to space constraints, the PMC voltage keying holes are not present on CCPMC adapters.

4.3 PCI-104

CCII/SIO/PC104/8P	3,3 V PCI signalling only (not 5 V tolerant)	8 x SCC, 4 x SMC
CCII/SIO/PC104/4PN	3,3 V PCI signalling only (not 5 V tolerant)	4 x SCC, 2 x SMC

The PC/104 slot has to be set using the slot switch SW1 (Refer to Figure 9).

Channel A and Channel B support RS-232 and RS-422/485. The other SCC channels support RS-422/485.

4.4 PCI

CCII/SIO/PCI/8P	3,3 V PCI signalling only (not 5 V tolerant)	8 x SCC, 4 x SMC
CCII/SIO/PCI/4PN	3,3 V PCI signalling only (not 5 V tolerant)	4 x SCC, 2 x SMC
CCII/SIO/PCI/8P/FP3	3,3 V or 5 V PCI signalling (5 V tolerant)	8 x SCC, 4 x SMC
CCII/SIO/PCI/4PN/FP3	3,3 V or 5 V PCI signalling (5 V tolerant)	4 x SCC, x SMC

CCII/HSS8/6-MAN/001	2013-08-30	Issue 1.8
CH8MAN01.wpd		Page 12 of 39

5. Connector Pin Assignments

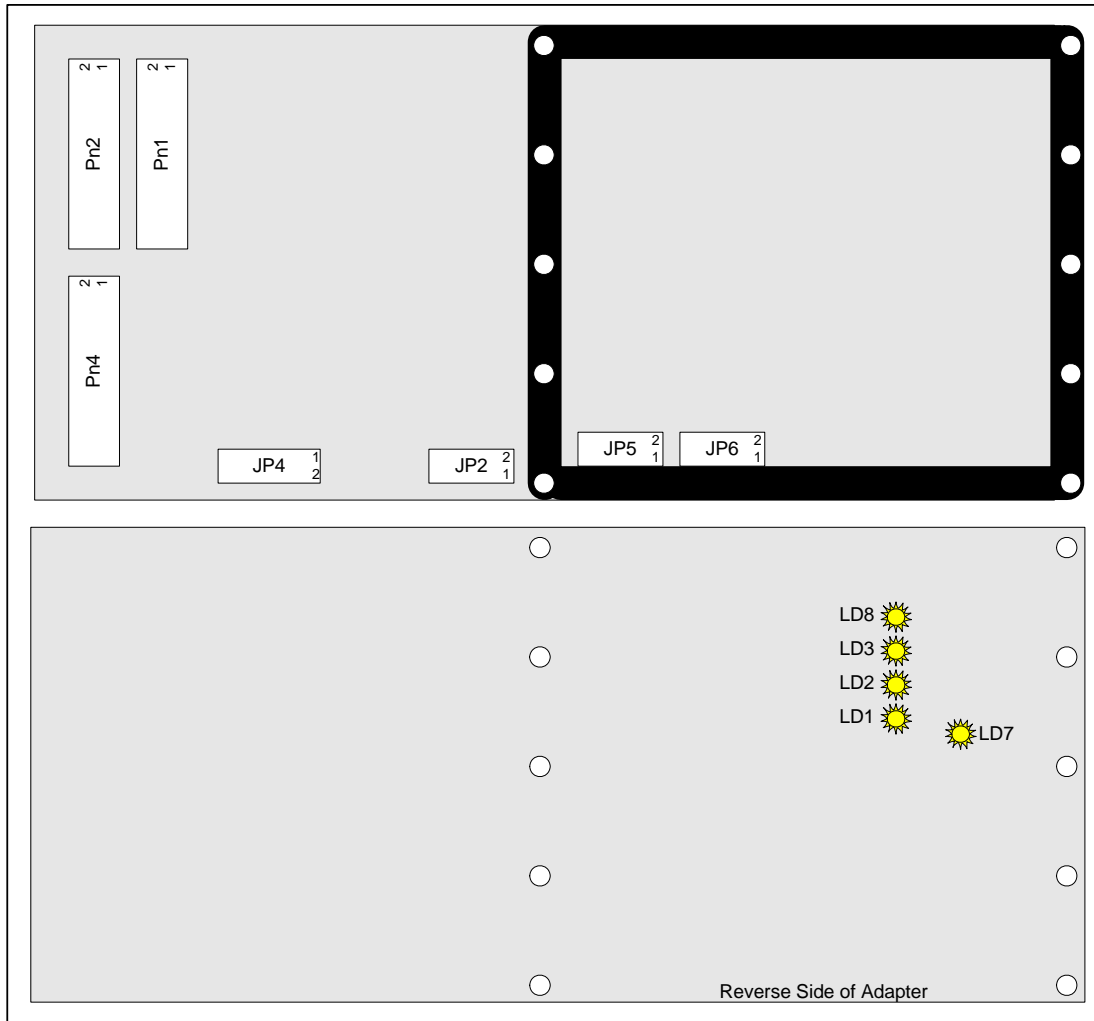

Figure 2 : Connector Locations on the HSS8 CCPMC and HSS4NG Adapters (Mod 0)

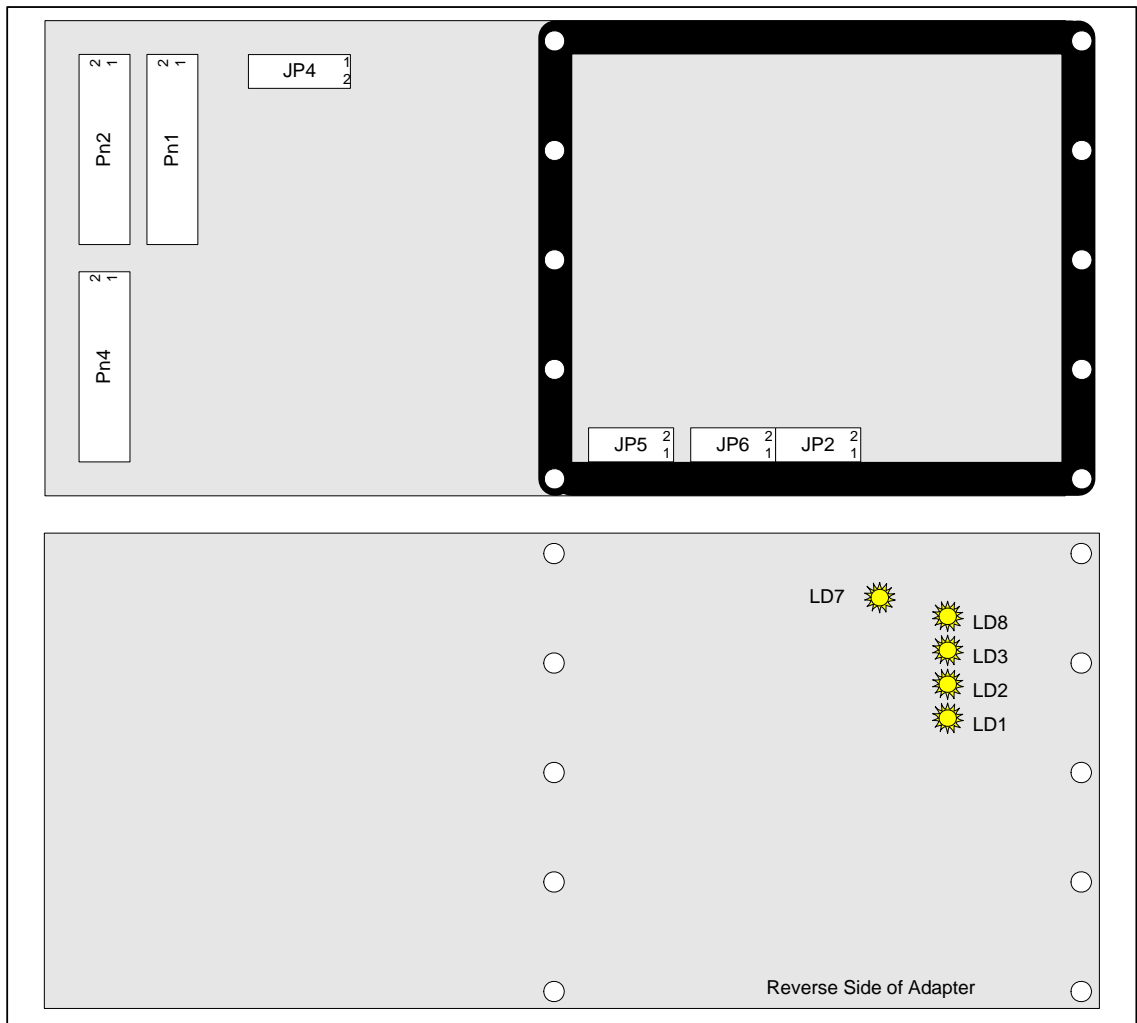

Figure 3 : Connector Locations on the HSS8 CCPMC and HSS4NG Adapters (Mod 1 and above)

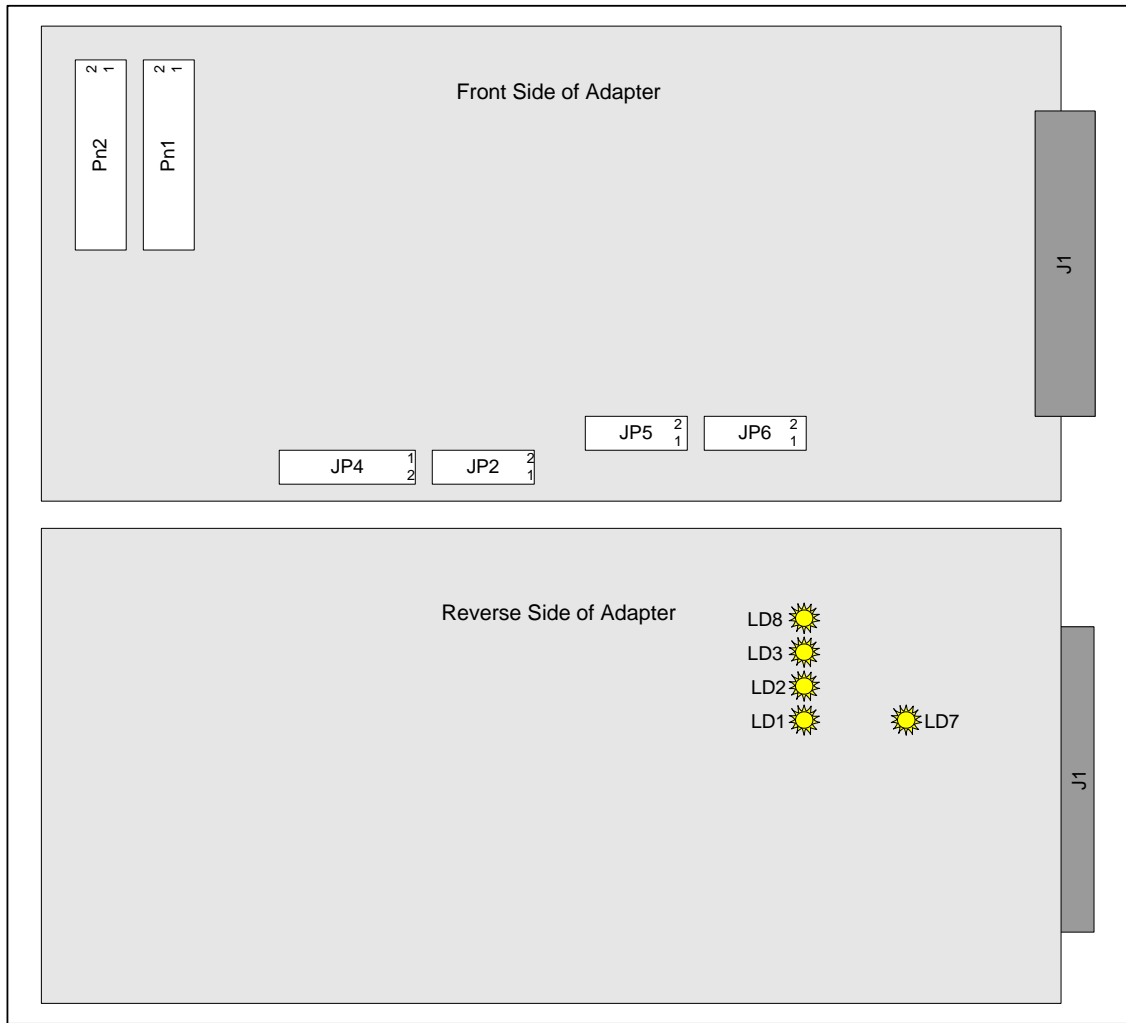

Figure 4 : Connector Locations on the HSS8 PMC and HSS4NG Adapters (FP)

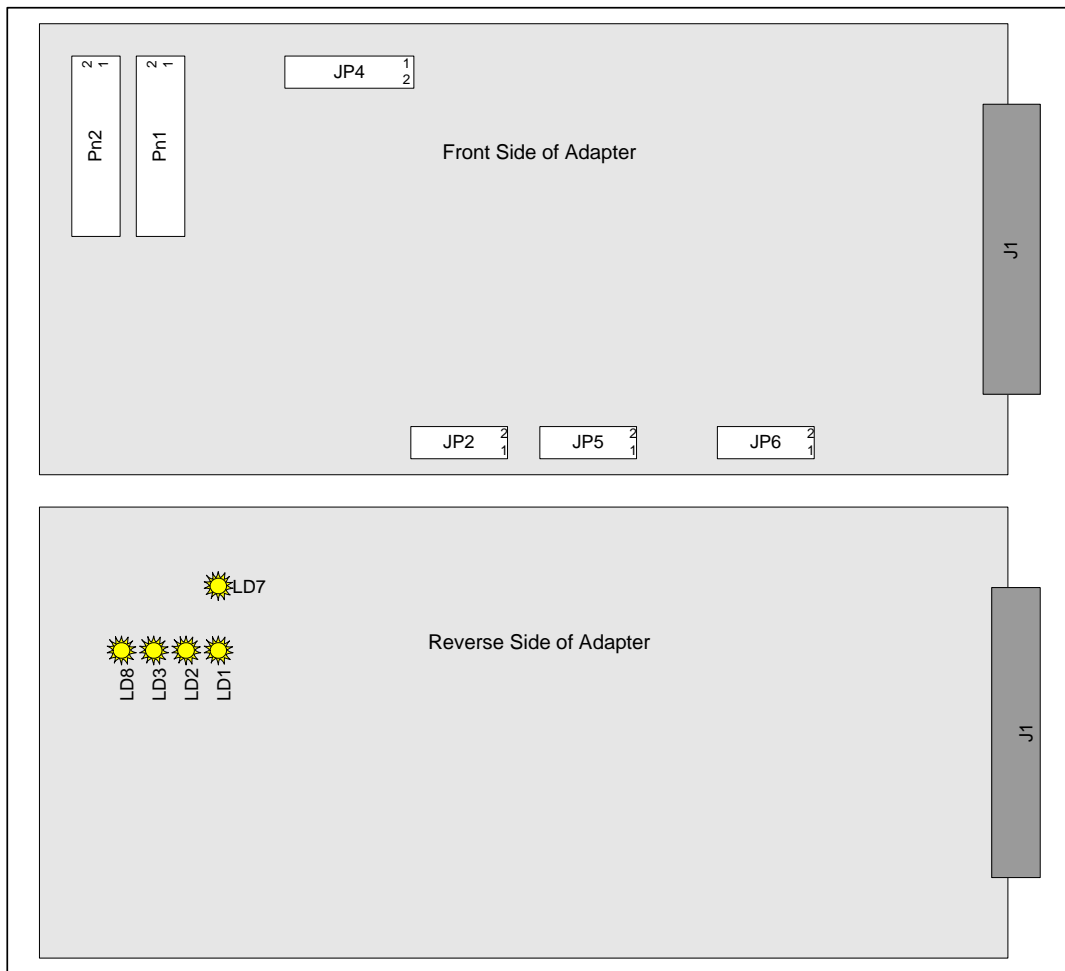

Figure 5 : Connector Locations on the HSS8 PMC and HSS4NG Adapters (FP1)

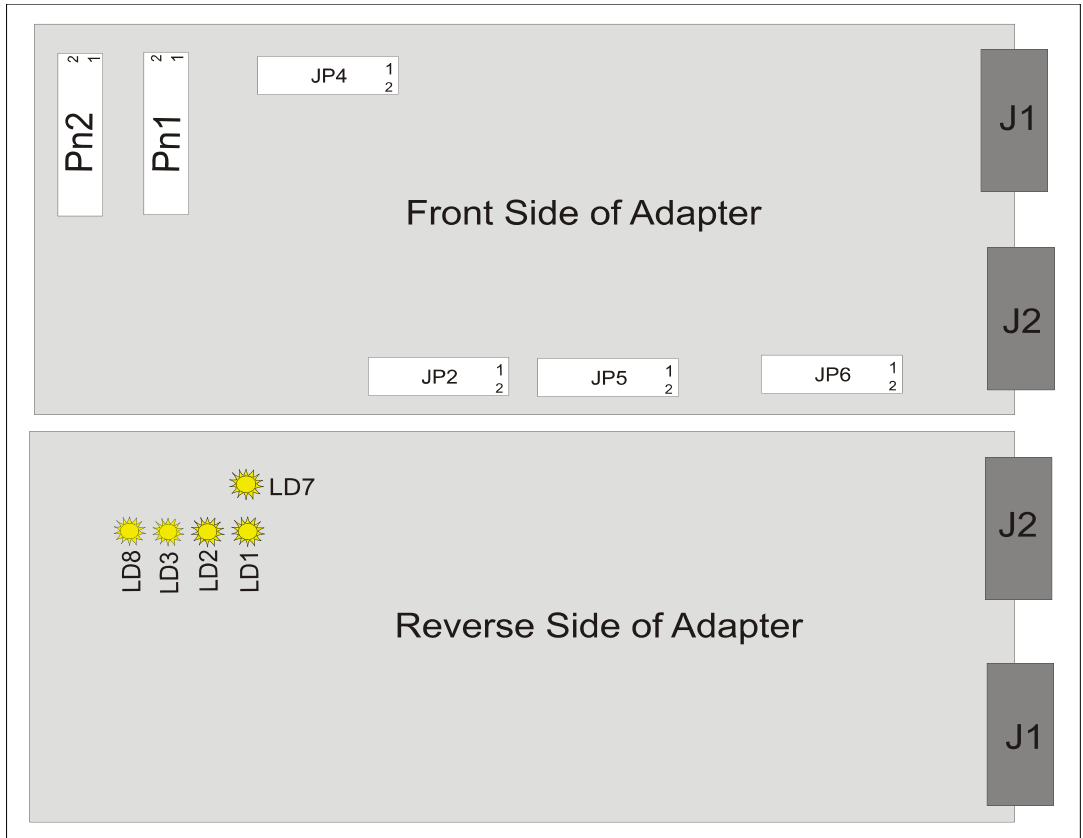

Figure 6 : Connector Locations on the HSS8 PMC and HSS4NG PMC Adapters (FP3)

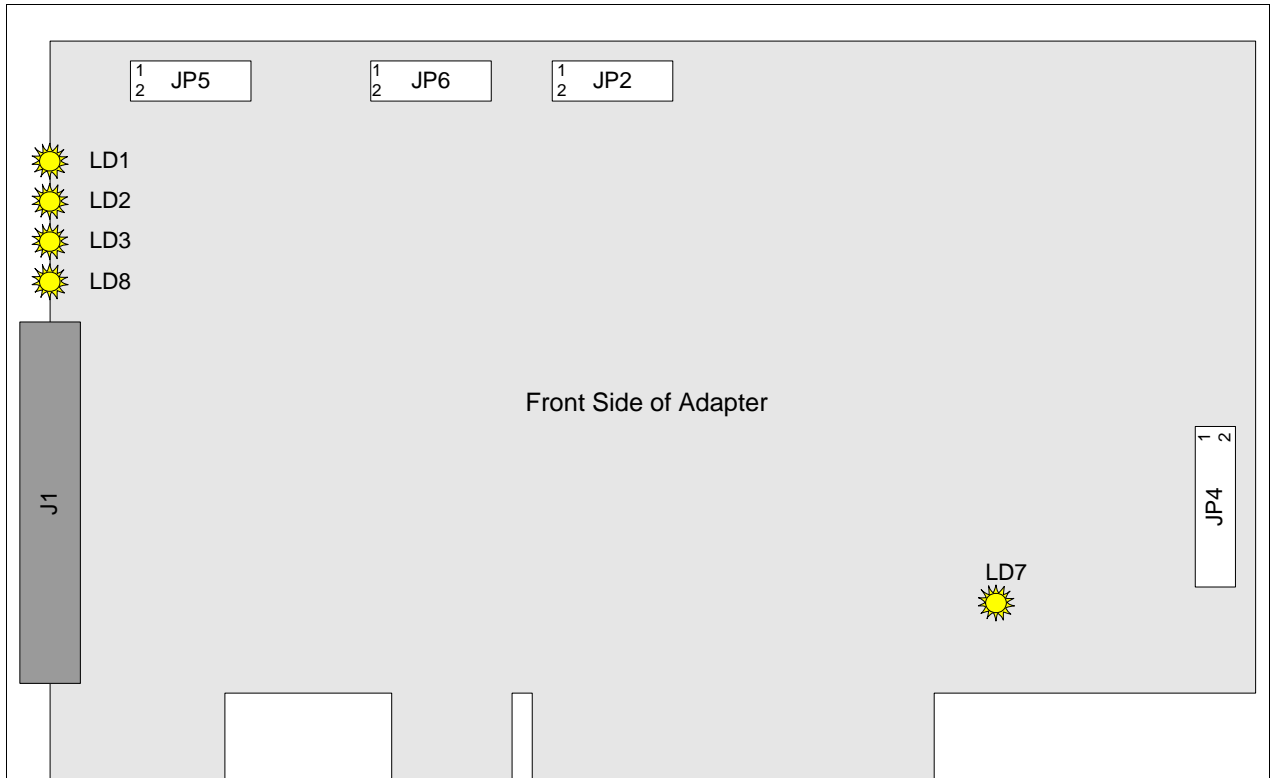

Figure 7 : Connector Locations on the HSS8 PCI and HSS4NG PCI Adapters (FP)

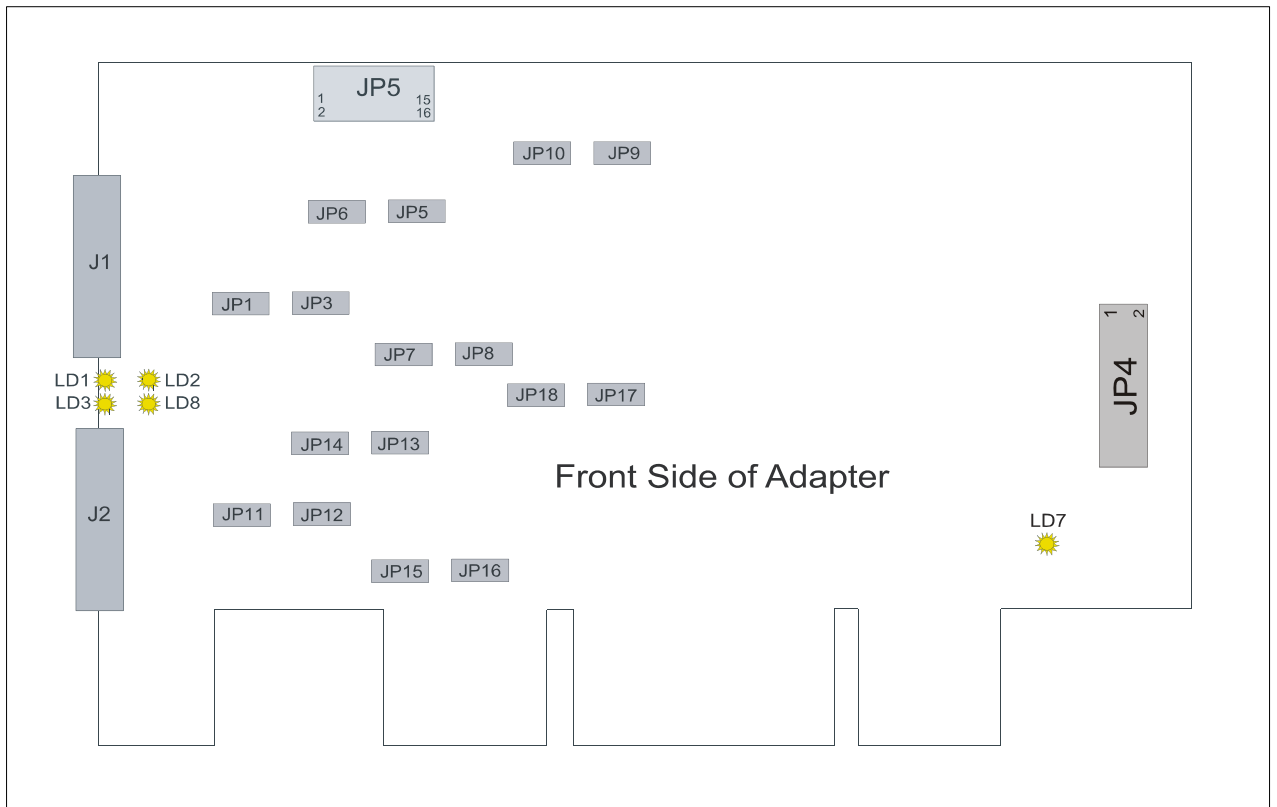

Figure 8 : Connector Locations for the HSS8 PCI and HSS4NG PCI Adapters (FP3)

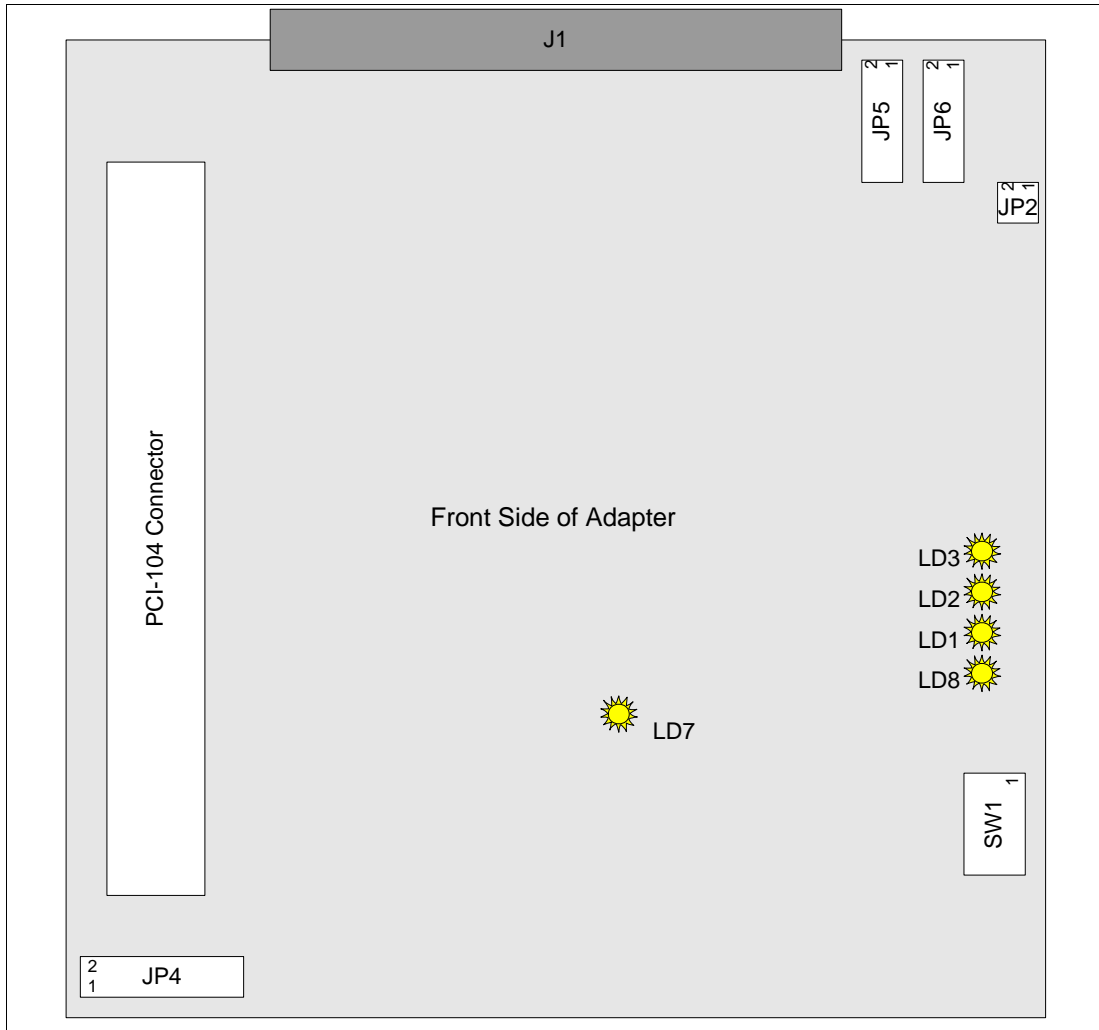

Figure 9 : Connector Locations on the HSS8 PCI-104 and HSS4NG PCI-104 Adapters (FP)

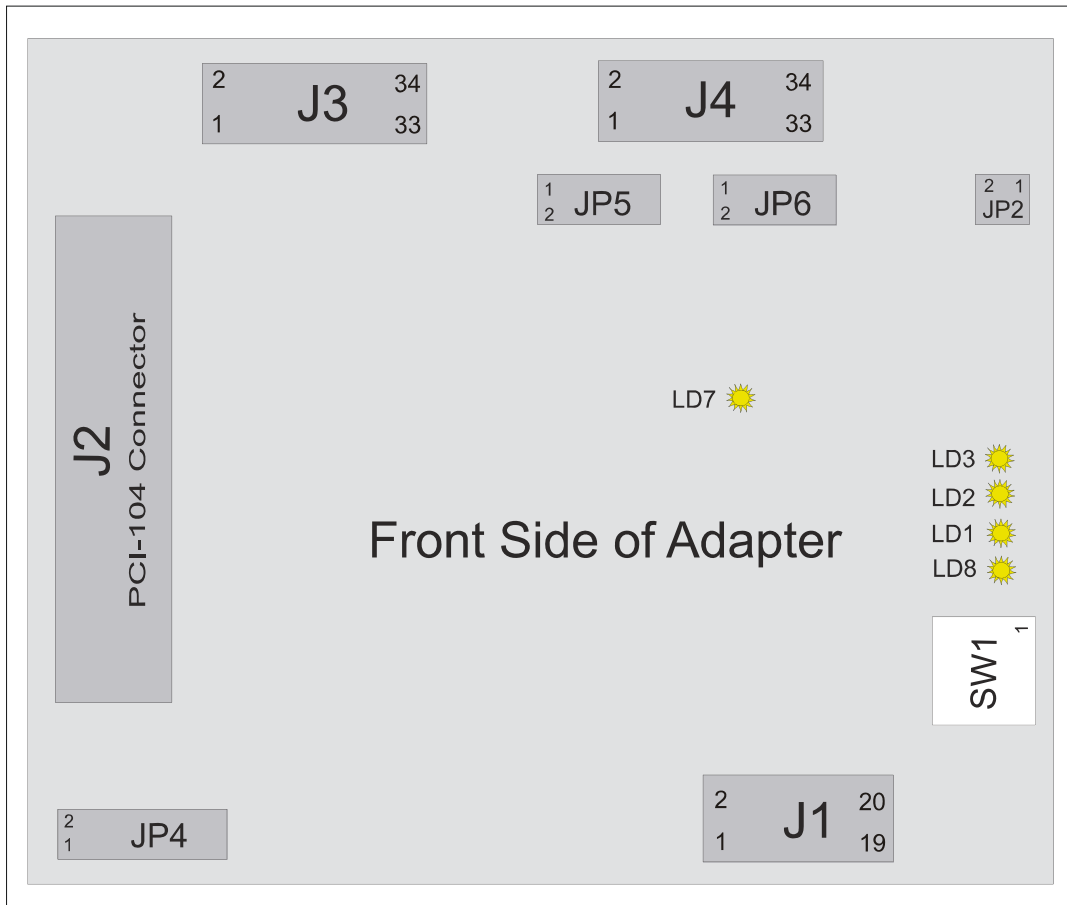

Figure 10 : Connector Locations on HSS8 PCI-104 and HSS4NG PCI-104 Adapters (FP3)

6. **Serial I/O Connectors**

6.1 PMC I/O Connector

Pn4 Signals (Rear Panel Configuration Only)					
Pin	Signal Name		Signal Name		Pin
	RS-232	RS-422/485	RS-232	RS-422/485	
Channel A					
1	A_TxD	A_TxD+	A_CLK_OUT	A_TxD-	2
3	A_RxD	A_RxD+	A_CLK_IN	A_RxD-	4
5		A_CLK_OUT+	A_RTS	A_CLK_OUT-	6
7	A_CTS	A_CLK_IN+	A_CD	A_CLK_IN-	8
Channel B					
9	B_TxD	B_TxD+	B_CLK_OUT	B_TxD-	10
11	B_RxD	B_RxD+	B_CLK_IN	B_RxD-	12
13		B_CLK_OUT+	B_RTS	B_CLK_OUT-	14
15	B_CTS	B_CLK_IN+	B_CD	B_CLK_IN-	16
Channel C					
17	C_TxD	C_TxD+	C_CLK_OUT	C_TxD-	18
19	C_RxD	C_RxD+	C_CLK_IN	C_RxD-	20
21		C_CLK_OUT+	C_RTS	C_CLK_OUT-	22
23	C_CTS	C_CLK_IN+	C_CD	C_CLK_IN-	24
Channel D					
25	D_TxD	D_TxD+	D_CLK_OUT	D_TxD-	26
27	D_RxD	D_RxD+	D_CLK_IN	D_RxD-	28
29		D_CLK_OUT+	D_RTS	D_CLK_OUT-	30
31	D_CTS	D_CLK_IN+	D_CD	D_CLK_IN-	32

Table 8 : SCC Signal Pins on the Pn4 Connector for CCPMC Adapters

Pn4 Signals (Rear Panel Configuration Only)					
Pin	Signal Name		Signal Name		Pin
	RS-232	RS-422/485	RS-232	RS-422/485	
Channel E (Not available on HSS4NG)					
33	E_TxD	E_TxD+	E_CLK_OUT	E_TxD-	34
35	E_RxD	E_RxD+	E_CLK_IN	E_RxD-	36
37		E_CLK_OUT+	E_RTS	E_CLK_OUT-	38
39	E_CTS	E_CLK_IN+	E_CD	E_CLK_IN-	40
Channel F (Not available on HSS4NG)					
41	F_TxD	F_TxD+	F_CLK_OUT	F_TxD-	42
43	F_RxD	F_RxD+	F_CLK_IN	F_RxD-	44
45		F_CLK_OUT+	F_RTS	F_CLK_OUT-	46
47	F_CTS	F_CLK_IN+	F_CD	F_CLK_IN-	48
Channel G (Not available on HSS4NG)					
49	G_TxD	G_TxD+	G_CLK_OUT	G_TxD-	50
51	G_RxD	G_RxD+	G_CLK_IN	G_RxD-	52
53		G_CLK_OUT+	G_RTS	G_CLK_OUT-	54
55	G_CTS	G_CLK_IN+	G_CD	G_CLK_IN-	56
Channel H (Not available on HSS4NG)					
57	H_TxD	H_TxD+	H_CLK_OUT	H_TxD-	58
59	H_RxD	H_RxD+	H_CLK_IN	H_RxD-	60
61		H_CLK_OUT+	H_RTS	H_CLK_OUT-	62
63	H_CTS	H_CLK_IN+	H_CD	H_CLK_IN-	64

Table 9 : SCC Signal Pins on the Pn4 Connector for CCPMC Adapters (Not available on HSS4NG)

J1 Signal Pins for SCC Channels					
Pin	Signal Name		Signal Name		Pin
	RS-232	RS-422/485	RS-232	RS-422/485	
Channel A					
2	A_TxD	A_TxD+	A_CLK_OUT	A_TxD-	3
5	A_RxD	A_RxD+	A_CLK_IN	A_RxD-	6
8		A_CLK_OUT+	A_RTS	A_CLK_OUT-	9
11	A_CTS	A_CLK_IN+	A_CD	A_CLK_IN-	12
Channel B					
14	B_TxD	B_TxD+	B_CLK_OUT	B_TxD-	15
17	B_RxD	B_RxD+	B_CLK_IN	B_RxD-	18
20		B_CLK_OUT+	B_RTS	B_CLK_OUT-	21
23	B_CTS	B_CLK_IN+	B_CD	B_CLK_IN-	24
Channel C					
32	C_TxD	C_TxD+	C_CLK_OUT	C_TxD-	33
35	C_RxD	C_RxD+	C_CLK_IN	C_RxD-	36
38		C_CLK_OUT+	C_RTS	C_CLK_OUT-	39
41	C_CTS	C_CLK_IN+	C_CD	C_CLK_IN-	42
Channel D					
44	D_TxD	D_TxD+	D_CLK_OUT	D_TxD-	45
47	D_RxD	D_RxD+	D_CLK_IN	D_RxD-	48
50		D_CLK_OUT+	D_RTS	D_CLK_OUT-	51
53	D_CTS	D_CLK_IN+	D_CD	D_CLK_IN-	54

Table 10 : SCC Signal Pins on J1 Connector for FP1 Adapters

J1 Signal Pins for SCC Channels					
Pin	Signal Name		Signal Name		Pin
	RS-232	RS-422/485	RS-232	RS-422/485	
Channel E (Not available on HSS4NG)					
62	E_TxD	E_TxD+	E_CLK_OUT	E_TxD-	63
65	E_RxD	E_RxD+	E_CLK_IN	E_RxD-	66
68		E_CLK_OUT+	E_RTS	E_CLK_OUT-	69
71	E_CTS	E_CLK_IN+	E_CD	E_CLK_IN-	72
Channel F (Not available on HSS4NG)					
74	F_TxD	F_TxD+	F_CLK_OUT	F_TxD-	75
77	F_RxD	F_RxD+	F_CLK_IN	F_RxD-	78
80		F_CLK_OUT+	F_RTS	F_CLK_OUT-	81
83	F_CTS	F_CLK_IN+	F_CD	F_CLK_IN-	84
Channel G (Not available on HSS4NG)					
92	G_TxD	G_TxD+	G_CLK_OUT	G_TxD-	93
95	G_RxD	G_RxD+	G_CLK_IN	G_RxD-	96
98		G_CLK_OUT+	G_RTS	G_CLK_OUT-	99
101	G_CTS	G_CLK_IN+	G_CD	G_CLK_IN-	102
Channel H (Not available on HSS4NG)					
104	H_TxD	H_TxD+	H_CLK_OUT	H_TxD-	105
107	H_RxD	H_RxD+	H_CLK_IN	H_RxD-	108
110		H_CLK_OUT+	H_RTS	H_CLK_OUT-	111
113	H_CTS	H_CLK_IN+	H_CD	H_CLK_IN-	114

Table 11 : SCC Signals Pins on J1 Connector for FP1 Adapters (Not available on HSS4NG)

J1 Signal Pins for SMC Channels			
Pin	Signal Name		Pin
	RS-232		RS-232
Channel I			
26	I_TxD	I_RxD	27
Channel J			
56	J_TxD	J_RxD	57
Channel K (Not available on HSS4NG)			
86	K_TxD	K_RxD	87
Channel L (Not available on HSS4NG)			
116	L_TxD	L_RxD	117

Table 12 : SMC Signal Pins on J1 Connector for FP1 Adapters

J1 Signal Pins for LEDs			
Pin	Signal Name	Signal Name	Pin
LED 1			
29	LD1_A	LD1_K	30
LED 2			
59	LD2_A	LD2_K	60
LED 3			
89	LD3_A	LD3_K	90
LED 8			
119	LD8_A	LD8_K	120

Table 13 : LED Signal Pins on J1 Connector for FP1 Adapters

J1 Signal Pins for Ground	
Pin	Signal Name
1, 4, 7, 10, 13, 16, 19, 22, 25, 28, 31, 34, 37, 40, 43, 46, 49, 52, 55, 58, 61, 64, 67, 70, 73, 76, 79, 82, 85, 88, 91, 94, 97, 100, 103, 106, 109, 112, 115, 118	GND

Table 14 : Ground Signal Pins on J1 Connector for FP1 Adapters

J1 Signal Pins for SCC Channels					
Pin	Signal Name		Signal Name		Pin
	RS232	RS422/485	RS232	RS422/485	
Channel A					
1	A_TxD	A_TxD+	A_CLK_OUT	A_TxD-	2
3	A_RxD	A_RxD+	A_CLK_IN	A_RxD-	4
6		A_CLK_OUT+	A_RTS	A_CLK_OUT-	7
8	A_CTS	A_CLK_IN+	A_CD	A_CLK_IN-	9
Channel B					
11	B_TxD	B_TxD+	B_CLK_OUT	B_TxD-	12
13	B_RxD	B_RxD+	B_CLK_IN	B_RxD-	14
16		B_CLK_OUT+	B_RTS	B_CLK_OUT-	17
18	B_CTS	B_CLK_IN+	B_CD	B_CLK_IN-	19
Channel C					
27	C_TxD	C_TxD+	C_CLK_OUT	C_TxD-	26
29	C_RxD	C_RxD+	C_CLK_IN	C_RxD-	28
31		C_CLK_OUT+	C_RTS	C_CLK_OUT-	32
33	C_CTS	C_CLK_IN+	C_CD	C_CLK_IN-	34
Channel D					
37	D_TxD	D_TxD+	D_CLK_OUT	D_TxD-	36
39	D_RxD	D_RxD+	D_CLK_IN	D_RxD-	38
41		D_CLK_OUT+	D_RTS	D_CLK_OUT-	42
43	D_CTS	D_CLK_IN+	D_CD	D_CLK_IN-	44

Table 15 : SCC Signal Pins on J1 Connector for the PMC and PCI FP3 Adapters

J1 Signal Pins for SMC Channels			
Pin	Signal Name		Pin
	RS232	RS232	
Channel I			
21	I_TxD	I_RxD	22
Channel J			
47	J_TxD	J_RxD	46

Table 16 : SMC Signal Pins on J1 Connector for the PMC and PCI FP3 Adapters

J1 Signal Pins for LEDs			
Pin	Signal Name	Signal Name	Pin
LED1		LED3	
23	LD1_A	LD3_A	49
LED2		LED8	
24	LD2_A	LD8_A	48

Table 17 : LED Signal Pins on J1 Connector for the PMC and PCI FP3 Adapters

Note : Only the Anode for the LEDs are wired to the connector and there are current-limiting resistors in the design for each pin. We suggest that the customer makes use of any of the pins detailed in Table 18 to connect to the Cathode of the LEDs.

J1 Signal Pins for Ground	
Pin	Signal Name
5, 10, 15, 20, 25, 30, 35, 40, 45, 50	Ground

Table 18 : Ground Signal Pins on J1 Connector for the PMC and PCI FP3 Adapters

J2 Signal Pins for SCC Channels					
Pin	Signal Name		Signal Name		Pin
	RS232	RS422/485	RS232	RS422/485	
Channel E (Not available on HSS4NG)					
1	E_TxD	E_TxD+	E_CLK_OUT	E_TxD-	2
3	E_RxD	E_RxD+	E_CLK_IN	E_RxD-	4
6		E_CLK_OUT+	E_RTS	E_CLK_OUT-	7
8	E_CTS	E_CLK_IN+	E_CD	E_CLK_IN-	9
Channel F (Not available on HSS4NG)					
11	F_TxD	F_TxD+	F_CLK_OUT	F_TxD-	12
13	F_RxD	F_RxD+	F_CLK_IN	F_RxD-	14
16		F_CLK_OUT+	F_RTS	F_CLK_OUT-	17
18	F_CTS	F_CLK_IN+	F_CD	F_CLK_IN-	19
Channel G (Not available on HSS4NG)					
27	G_TxD	G_TxD+	G_CLK_OUT	G_TxD-	26
29	G_RxD	G_RxD+	G_CLK_IN	G_RxD-	28
31		G_CLK_OUT+	G_RTS	G_CLK_OUT-	32
33	G_CTS	G_CLK_IN+	G_CD	G_CLK_IN-	34
Channel H (Not available on HSS4NG)					
37	H_TxD	H_TxD+	H_CLK_OUT	H_TxD-	36
39	H_RxD	H_RxD+	H_CLK_IN	H_RxD-	38
41		H_CLK_OUT+	H_RTS	H_CLK_OUT-	42
43	H_CTS	H_CLK_IN+	H_CD	H_CLK_IN-	44

Table 19 : SCC Signal Pins on J2 Connector for the PMC and PCI FP3 Adapters (Not available on HSS4NG)

J2 Signal Pins for SMC Channels			
Pin	Signal Name		Pin
	RS232	RS232	
Channel K (Not available on HSS4NG)			
21	K_TxD	K_RxD	22
Channel L (Not available on HSS4NG)			
47	L_TxD	L_RxD	46

Table 20 : SMC Signal Pins on J2 Connector for the PMC and PCI FP3 Adapters (Not available on HSS4NG)

J2 Signal Pins for LEDs (Not available on HSS4NG)			
Pin	Signal Name	Signal Name	Pin
LED1		LED3	
23	LD1_A	LD3_A	49
LED2		LED8	
24	LD2_A	LD8_A	48

Table 21 : LED Signal Pins on J2 Connector for the PMC and PCI FP3 Adapters (Not available on HSS4NG)

Note : Only the Anodes for the LEDs are wired to the connector and there are current-limiting resistors in the design for each pin. We suggest that the customer makes use of any of the pins listed in Table 22 to connect to the Cathode of the LEDs.

J2 Signal Pins for Ground	
Pin	Signal Name
5, 10, 15, 20, 25, 30, 35, 40, 45, 50	Ground

Table 22 : Ground Signal Pins on J2 Connector for the PMC and PCI FP3 Adapters

J3 Signal Pins for SCC Channels					
Pin	Signal Name		Signal Name		Pin
	RS232	RS422/485	RS232	RS422/485	
Channel A					
1	A_TxD	A_TxD+	A_CLK_OUT	A_TxD-	2
3	A_RxD	A_RxD+	A_CLK_IN	A_RxD-	4
5		A_CLK_OUT+	A_RTS	A_CLK_OUT-	6
7	A_CTS	A_CLK_IN+	A_CD	A_CLK_IN-	8
Channel B					
9	B_TxD	B_TxD+	B_CLK_OUT	B_TxD-	10
11	B_RxD	B_RxD+	B_CLK_IN	B_RxD-	12
13		B_CLK_OUT+	B_RTS	B_CLK_OUT-	14
15	B_CTS	B_CLK_IN+	B_CD	B_CLK_IN-	16
Channel C					
19	C_TxD	C_TxD+	C_CLK_OUT	C_TxD-	20
21	C_RxD	C_RxD+	C_CLK_IN	C_RxD-	22
23		C_CLK_OUT+	C_RTS	C_CLK_OUT-	24
25	C_CTS	C_CLK_IN+	C_CD	C_CLK_IN-	26
Channel D					
27	D_TxD	D_TxD+	D_CLK_OUT	D_TxD-	28
29	D_RxD	D_RxD+	D_CLK_IN	D_RxD-	30
31		D_CLK_OUT+	D_RTS	D_CLK_OUT-	32
33	D_CTS	D_CLK_IN+	D_CD	D_CLK_IN-	34

Table 23 : SCC Signal Pins on J3 Connector for the PCI-104 FP3 Adapters

J3 Signal Pins for Ground	
Pin	Signal Name
17, 18	Ground

Table 24 : Ground Signal Pins on J3 Connector for the PCI-104 FP3 Adapters

J4 Signal Pins for SCC Channels (Not available on HSS4NG)					
Pin	Signal Name		Signal Name		Pin
	RS232	RS422/485	RS232	RS422/485	
Channel E (Not available on HSS4NG)					
1	E_TxD	E_TxD+	E_CLK_OUT	E_TxD-	2
3	E_RxD	E_RxD+	E_CLK_IN	E_RxD-	4
5		E_CLK_OUT+	E_RTS	E_CLK_OUT-	6
7	E_CTS	E_CLK_IN+	E_CD	E_CLK_IN-	8
Channel F (Not available on HSS4NG)					
9	F_TxD	F_TxD+	F_CLK_OUT	F_TxD-	10
11	F_RxD	F_RxD+	F_CLK_IN	F_RxD-	12
13		F_CLK_OUT+	F_RTS	F_CLK_OUT-	14
15	F_CTS	F_CLK_IN+	F_CD	F_CLK_IN-	16
Channel G (Not available on HSS4NG)					
19	G_TxD	G_TxD+	G_CLK_OUT	G_TxD-	20
21	G_RxD	G_RxD+	G_CLK_IN	G_RxD-	22
23		G_CLK_OUT+	G_RTS	G_CLK_OUT-	24
25	G_CTS	G_CLK_IN+	G_CD	G_CLK_IN-	26
Channel H (Not available on HSS4NG)					
27	H_TxD	H_TxD+	H_CLK_OUT	H_TxD-	28
29	H_RxD	H_RxD+	H_CLK_IN	H_RxD-	30
31		H_CLK_OUT+	H_RTS	H_CLK_OUT-	32
33	H_CTS	H_CLK_IN+	H_CD	H_CLK_IN-	34

Table 25 : SCC Signal Pins on J4 Connector for the PCI-104 FP3 Adapters (Not available on HSS4NG)

J4 Signal Pins for Ground	
Pin	Signal Name
17, 18	Ground

Table 26 : Ground Signal Pins on J4 Connector for the PCI-104 FP3 Adapters

6.7 J1 (Samtec) I/O Connector

J1 Signal Pins for SMC Channels			
Pin	Signal Name	Signal Name	Pin
RS232		RS232	
Channel I			
1	I_TxD	I_RxD	2
Channel J			
3	J_TxD	J_RxD	4
Channel K (Not available on HSS4NG)			
7	K_TxD	K_RxD	8
Channel L (Not available on HSS4NG)			
9	L_TxD	L_RxD	10
J1 Signals for LEDs			
Pin	Signal Name	Signal Name	Pin
LED1			
13	LD1_A	LD1_K	14
LED2			
15	LD2_A	LD2_K	16
LED3			
17	LD3_A	LD3_K	18
LED8			
19	LD8_A	LD8_K	20

Table 27 : SMC AND LED Signal Pins on J1 Connector for the PC-104 FP3 Adapters

J1 Signal Pins for Ground	
Pin	Signal Name
5, 6, 11, 12	Ground

Table 28 : Ground Signal Pins on J4 Connector for the PCI-104 FP3 Adapters

6.8 Notes

Pn4, J1 (Molex), J1 (Tyco), J2 (Tyco), J1 (Samtec), J3 (Samtec) and J4 (Samtec) signals are configured such that the adapter channels function as Data Terminal Equipment (DTE). This specifies the I/O direction of the adapter's signals as follows :

- TxD is an output
- RxD is an input
- RTS is an output
- CTS is an input
- CD is an input
- CLK_OUT is an output
- CLK_IN is an input

An RS-232 logical zero is defined as a positive voltage between +3 V and +15 V. A logical one is defined as a negative voltage levels between -3 V and -15 V. The system +5 V line is a good source of a logical zero if required (a series resistor is recommended).

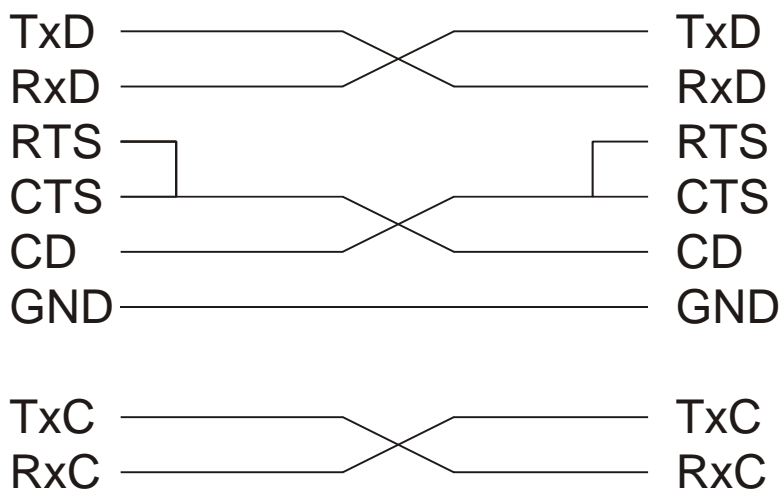

RS-232 Loopback
Cable

Annexure A

Molex 120-Pin Connector

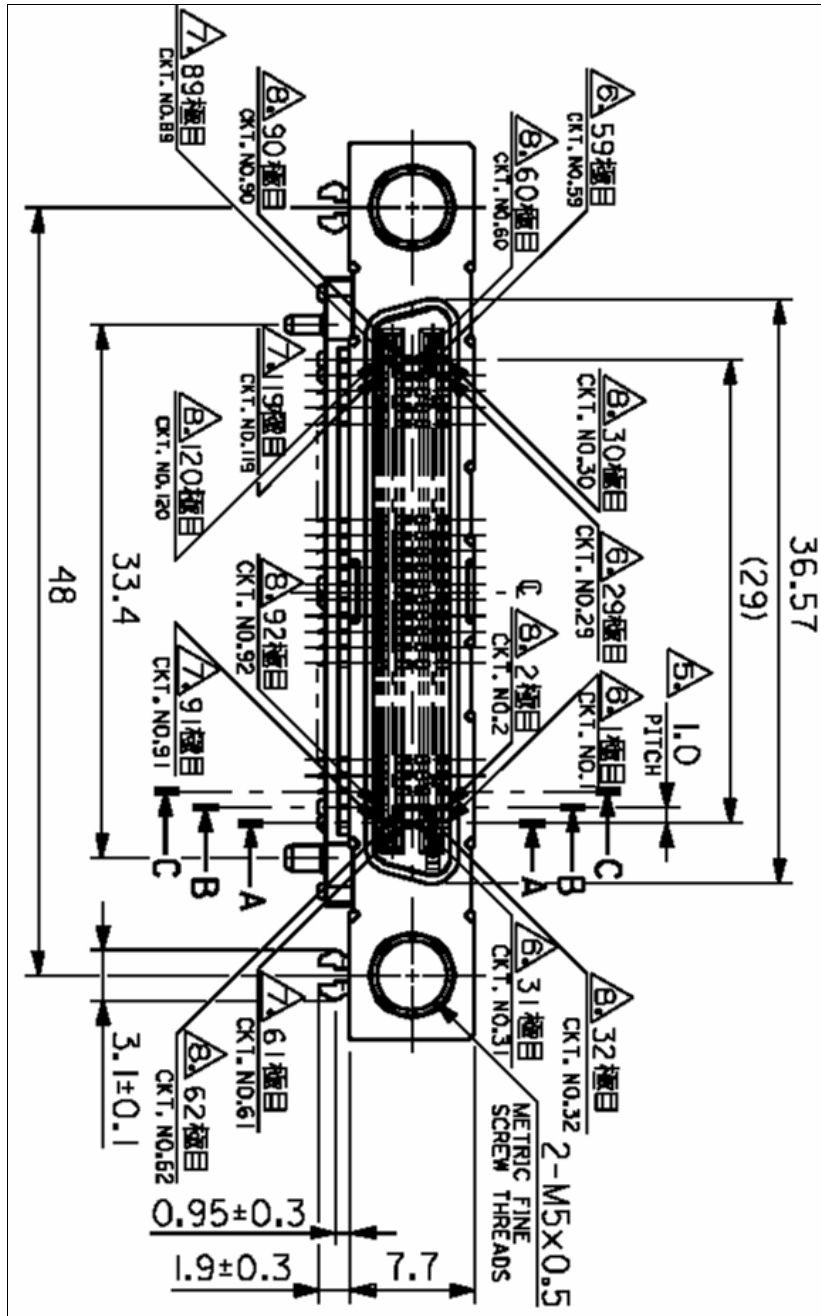

Figure 12 : Molex 120-Pin PCB Connector

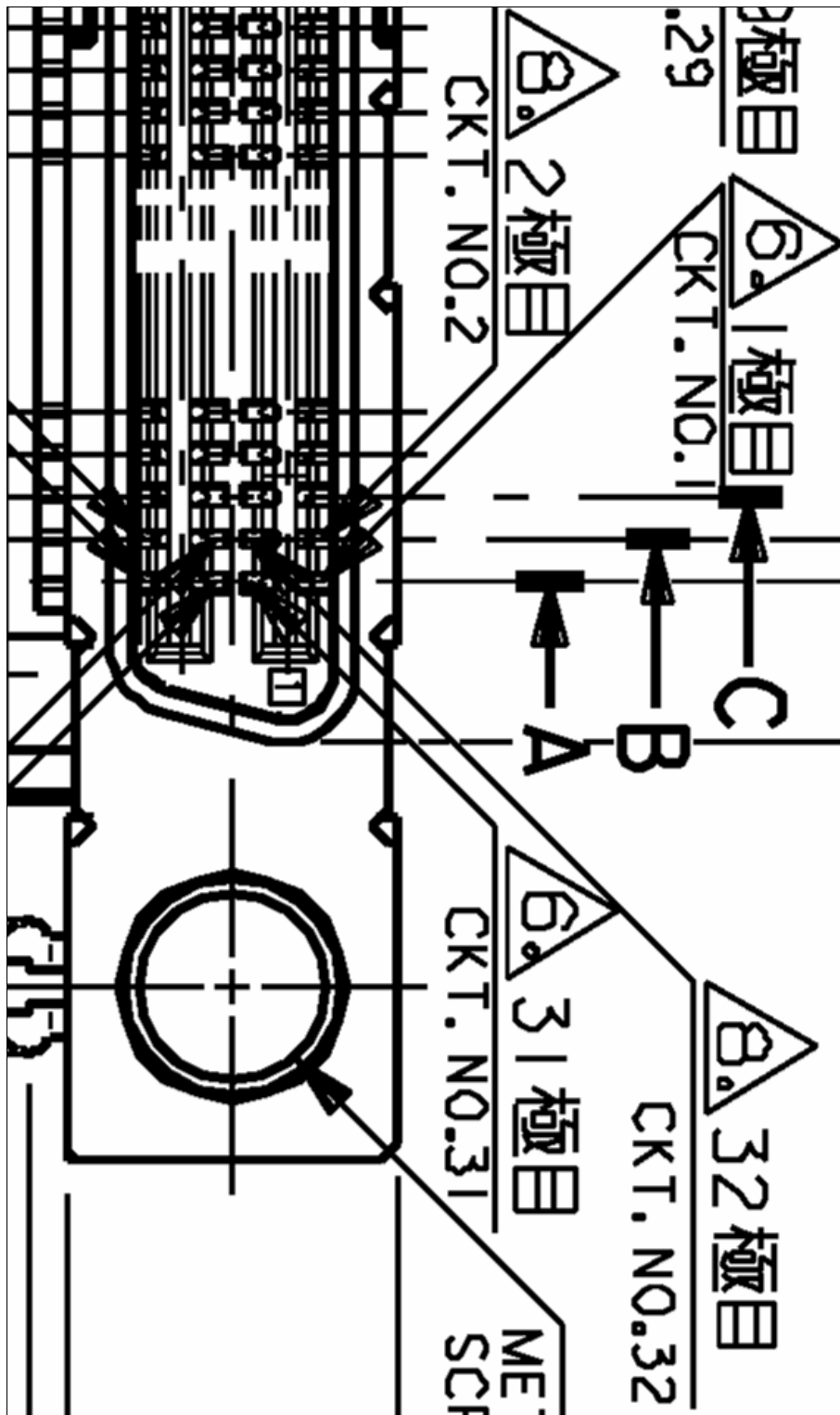

Figure 13 : Molex 120-Pin PCB Connector (Expanded View)

The frontpanel connector (J1) used on the FP and FP1 Adapters is a shielded right angle connector manufactured by Molex. A mating connector is supplied with each adapter. However, should the need arise to obtain further mating connectors, the ordering information is given below :

Description : Plug Assembly (Mating Connector)
Molex Part No. : 55032-1200

Description : Cover Assembly (Mating Connector)
Molex Part No. : 58423-1200

Description : Threaded Screw (Mating Connector)
Molex Part No. : 59811-0000

Above parts obtainable from the following agents :

Supplier Name : Intercomp USA, Inc.
Telephone No. : 001 954 493 6461
Email Address : Sales@intercomp.com
URL : <http://www.intercomp.com/>

The ordering information for the required ribbon cable is as follows :

Description : 1 mm Pitch Ribbon Cable 50-way
Part Number : CABFAWG2850M

Above parts obtainable from the following agent :

Supplier Name : Action Electronics
Telephone No. : 1 800 563 9405
Email Address : sales@action-electronics.com
URL : <http://www.action-electronics.com/>

A Serial I/O Cable Assembly and/or a Partial Cable Assembly can be ordered from C²I² Systems :

Supplier Name : C²I² Systems
Telephone No. : (+27) (0)21 683 5490
Email Address : sales@ccii.co.za
URL : <http://www.ccii.co.za>

CCII/HSS8/6-MAN/001	2013-08-30	Issue 1.8
CH8MAN01.wpd		Page 36 of 39

Annexure B

Tyco 50-Pin Connector

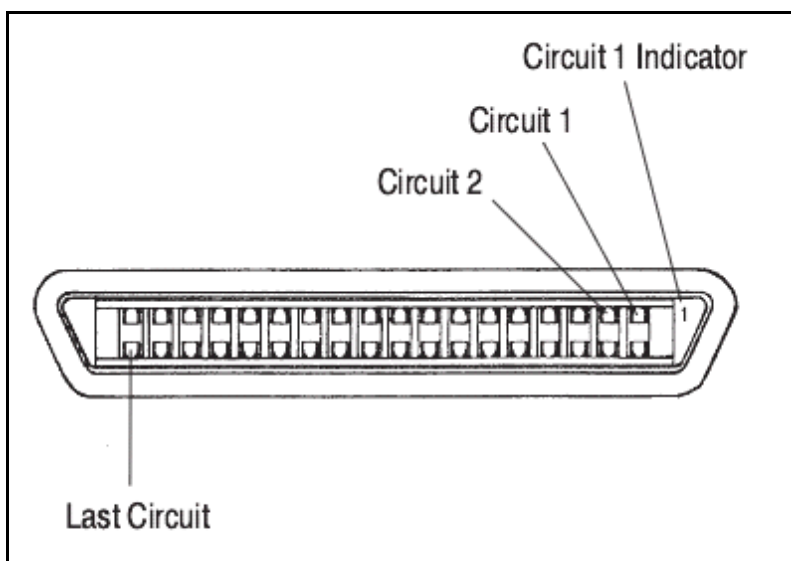

Figure 14 : Tyco 50-Pin PCB Connector

The frontpanel connectors (J1 and J2) used on the FP3 Adapters, are manufactured by Tyco. Mating connectors are supplied with each adapter. However, should the need arise to obtain further mating connectors, the ordering information is given below :

Description : 50 way IDC Cable Connector
Tyco Part No. : 5787233-1
See :



Description : Terminal Cover
Tyco Part No. : 787056-1 (set of 2)
Description : Connector
Tyco Part No. : 786930-4

Figure 15 :50 way
Connector Kit Parts

CCII/HSS8/6-MAN/001	2013-08-30	Issue 1.8
CH8MAN01.wpd		Page 37 of 39

Description : 50 way IDC Cable Connector Backshell Kit
 Tyco Part No. : 5787233-1
 Consisting of :
 :



Description : Cover
 Tyco Part No. : 787234-1 (set of 2)

Description : Backshell, Plated
 Tyco Part No. : 786969-2 (set of 2)

Description : Jackscrew
 Tyco Part No. : 787062-1 (set of 2)

Above parts obtainable from the following agents :

Supplier Name : Intercomp USA, Inc.
 Telephone No. : 001 954 493 6461
 Email Address : Sales@intercomp.com
 URL : <http://www.intercomp.com/>

Supplier Name : Digi-Key Corporation
 Telephone No. : 1-800-344-4539 or 218-681-6674 or Fax: 218-681-3380
 URL : <http://www.digikey.com/>
 Physical Address : 701 Brooks Avenue South, Thief River Falls, MN 56701 USA

The ordering information for the required ribbon cable is as follows :

Description : 1,27 mm flat cable
 Part Number : 523-125-3017-068

Above parts obtainable from the following agent :

Supplier Name : Mouser Electronics
 URL : www.mouser.com

A Serial I/O Cable Assembly and/or a Partial Cable Assembly can be ordered from C²I² Systems :

Supplier Name : C²I² Systems
 Telephone No. : (+27) (0)21 683 5490
 Email Address : sales@ccii.co.za
 URL : <http://www.ccii.co.za>

CCII/HSS8/6-MAN/001	2013-08-30	Issue 1.8
CH8MAN01.wpd		Page 38 of 39

Annexure C

Samtec 20-Pin and 34-Pin Connector

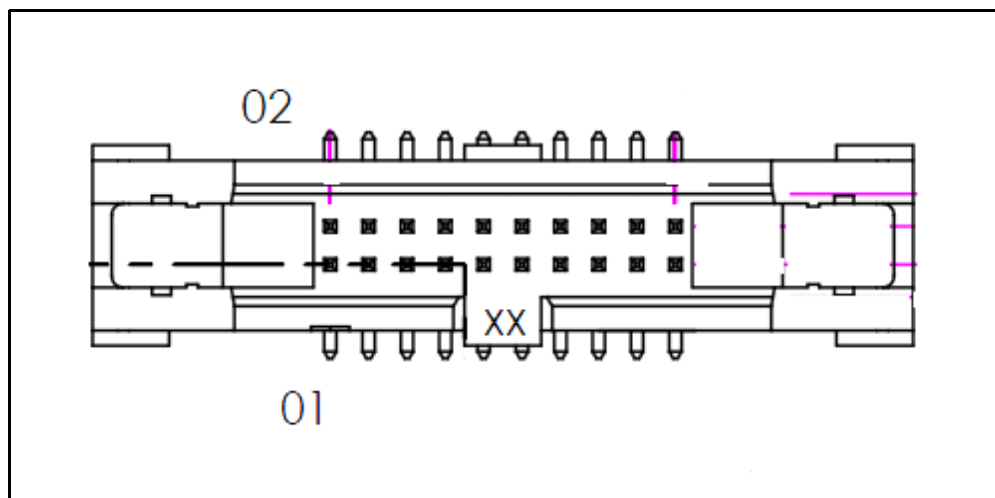

Figure 17 : Samtec 20-Pin and 34-Pin PCB Connector

The connectors, J1, J3 and J4 used on the FP3 PCI-104 Adapters, are surface mount headers manufactured by Samtec. Mating connectors are supplied with each adapter. However, should the need arise to obtain further mating connectors, the ordering information is given below :

Description : 20 Way IDC Ribbon Cable Assembly (Mating Connector)
Samtec Part No. : FFSD-10-S-12.00-01-N

Description : 34 Way IDC Twisted Pair Cable Assembly (Mating Connector)
Samtec Part No. : FFTP-17-D-18.00-01-N

Above parts obtainable from the following agents :

Supplier Name : Samtec (Europe) Limited
Telephone No. : +44 1236 739292
Email Address : victoria.morrison@samtec.com
URL : <http://www.samtec.com/>

A Serial I/O Cable Assembly and/or a Partial Cable Assembly can be ordered from C²I² Systems :

Supplier Name : C²I² Systems
Telephone No. : (+27) (0)21 683 5490
Email Address : sales@ccii.co.za
URL : <http://www.ccii.co.za>

CCII/HSS8/6-MAN/001	2013-08-30	Issue 1.8
CH8MAN01.wpd		Page 39 of 39