

User's Manual Pub. 030247-01 Rev. A

1762 Analog Combo Module 4 Channels In / 4 Channels Out

Catalog Number: 1762sc-IF4OF4



Important Notes

1. Please read all the information in this owner's guide before installing the product.
2. The information in this owner's guide applies to hardware Series A and firmware version 1.00 or later.
3. This guide assumes that the reader has a full working knowledge of the relevant processor.

Notice

The products and services described in this owner's guide are useful in a wide variety of applications. Therefore, the user and others responsible for applying the products and services described herein are responsible for determining their acceptability for each application. While efforts have been made to provide accurate information within this owner's guide, Spectrum Controls assumes no responsibility for the accuracy, completeness, or usefulness of the information herein.

Under no circumstances will Spectrum Controls be responsible or liable for any damages or losses, including indirect or consequential damages or losses, arising out of either the use of any information within this owner's guide or the use of any product or service referenced herein.

No patent liability is assumed by Spectrum Controls with respect to the use of any of the information, products, circuits, programming, or services referenced herein.

The information in this owner's guide is subject to change without notice.

Limited Warranty

Spectrum Controls warrants that its products are free from defects in material and workmanship under normal use and service, as described in Spectrum Controls literature covering this product, for a period of 1 year. The obligations of Spectrum Controls under this warranty are limited to replacing or repairing, at its option, at its factory or facility, any product which shall, in the applicable period after shipment, be returned to the Spectrum Controls facility, transportation charges prepaid, and which after examination is determined, to the satisfaction of Spectrum Controls, to be thus defective.

This warranty shall not apply to any such equipment which shall have been repaired or altered except by Spectrum Controls or which shall have been subject to misuse, neglect, or accident. In no case shall the liability of Spectrum Controls exceed the purchase price. The aforementioned provisions do not extend the original warranty period of any product which has either been repaired or replaced by Spectrum Controls.

Table of Contents

IMPORTANT NOTES.....	II
NOTICE	II
LIMITED WARRANTY	II
CHAPTER 1 MODULE OVERVIEW	1-1
SECTION 1.1 GENERAL DESCRIPTION	1-1
SECTION 1.2 OUTPUT TYPES AND RANGES	1-1
SECTION 1.3 INPUT TYPES AND RANGES	1-2
SECTION 1.4 DATA FORMATS	1-2
SECTION 1.5 FILTER FREQUENCIES	1-3
SECTION 1.6 HARDWARE FEATURES	1-3
1.6.1 LED Indicator.....	1-4
SECTION 1.7 SYSTEM OVERVIEW	1-4
1.7.1 Module Power-up	1-4
1.7.2 Module Operation.....	1-4
CHAPTER 2 INSTALLATION AND WIRING.....	2-1
SECTION 2.1 COMPLIANCE TO EUROPEAN UNION DIRECTIVES.....	2-1
2.1.1 EMC Directive.....	2-1
2.1.2 Low Voltage Directive.....	2-1
SECTION 2.2 POWER REQUIREMENTS	2-1
SECTION 2.3 GENERAL CONSIDERATIONS	2-2
2.3.1 Hazardous Location Considerations.....	2-2
2.3.2 Prevent Electrostatic Discharge	2-3
2.3.3 Remove Power	2-3
2.3.4 Selecting a Location	2-3
SECTION 2.4 MOUNTING	2-4
2.4.1 Minimum Spacing	2-4
2.4.2 DIN Rail Mounting	2-4
2.4.3 Panel Mounting	2-5
SECTION 2.5 SYSTEM ASSEMBLY	2-5
SECTION 2.6 FIELD WIRING CONNECTIONS.....	2-6
2.6.1 Wiring Diagram	2-8
2.6.2 Wiring the Finger-Safe Terminal Block	2-8
2.6.3 Terminal Door Label.....	2-9
SECTION 2.7 MODULE INDICATORS.....	2-9
CHAPTER 3 CONFIGURING THE 1762SC-IF40F4 USING RSLOGIX 500.....	3-1
SECTION 3.1 THINGS YOU SHOULD KNOW	3-1
SECTION 3.2 MODULE MEMORY MAP	3-1
SECTION 3.3 ADD MODULE TO LOGIX 500.....	3-2
SECTION 3.4 MODULE CONFIGURATION.....	3-3
3.4.1 Output Data File (Configuration Data)	3-3
3.4.2 Output Channel Configuration (Channels 0 through 3)	3-4
3.4.3 Input Channel Configuration (Channels 4 and 5)	3-5
3.4.4 Input Channel Configuration (Channels 6 and 7).....	3-6
SECTION 3.5 READ INPUT DATA	3-8
SECTION 3.6 MODULE UPDATE TIME	3-9
APPENDIX A MODULE SPECIFICATIONS.....	A-1

PREFACE

Read this preface to familiarize yourself with the rest of the manual. This preface covers the following topics:

- Who should use this manual
- How to use this manual
- Related publications
- Conventions used in this manual
- Rockwell Automation support

Who Should Use This Manual

Use this manual if you are responsible for designing, installing, programming, or troubleshooting control systems that use Allen-Bradley I/O and/or compatible controllers, such as MicroLogix 1100, 1200 or 1400.

How to Use This Manual

As much as possible, we organized this manual to explain, in a task-by-task manner, how to install, configure, program, operate and troubleshoot a control system using the 1762sc-IF4OF4.

Related Documentation

The table below provides a listing of publications that contain important information about Allen-Bradley PLC systems.

Document Title	Document Number
MicroLogix™ 1200 User Manual	1762-UM001
MicroLogix™ 1200 Technical Data	1762-TD001
MicroLogix 1200 and MicroLogix 1500 Programmable Controllers Instruction Set Reference Manual	1762-RM001
Allen-Bradley Programmable Controller Grounding and Wiring Guidelines	1770-4.1

If you would like a manual, you can:

- Download a free electronic version from the internet at www.theautomationbookstore.com
- Purchase a printed manual by:
 - Contacting your local distributor or Rockwell Automation representative
 - Visiting www.theautomationbookstore.com and placing your order
 - Calling 1.800.963.9548 (USA/Canada) or 001.330.725.1574 (Outside USA/Canada)

Conventions Used in This Manual

The following conventions are used throughout this manual:

- Bulleted lists (like this one) provide information not procedural steps.
- Numbered lists provide sequential steps or hierarchical information.
- *Italic* type is used for emphasis
- **Bold** type identifies headings and sub-headings



- Attention Are used to identify critical information to the reader

Chapter 1

Module Overview

The 1762sc-IF4OF4 Combo module contains 4 analog input channels and 4 analog output channels. Each of the four input channels can be configured to read current, voltage, or thermocouple signals. The 4 analog output channels can be configured to drive either voltage or current. This chapter includes information about:

- General description
- Input / Output types and ranges
- Data Formats and filter frequencies
- Hardware Features
- System overview and module operation

Section 1.1 General Description

The combo supports current, voltage and thermocouple input types and current or voltage output types. The module digitally converts and stores analog data from any of the three input types mentioned above. The module also converts the digital value stored in each output channel's command word, to an analog current or voltage signal. Each input or output channel is individually configured via software for a specific input / output type, data format, and provides open-circuit, over-range, under-range detection and indication.

Section 1.2 Output Types and Ranges

The table below lists the output types and their associated ranges.

Table 1-1 (Output Types)

Output Type	Range (Over Range)
Voltage	0 to 5V (0 to 5.5V)
	1 to 5V (0 to 5.5V)
	+/- 10V (-11 to +11V)
	0 to 10V (0 to 11V)
Current	4 to 20 mA (3.92 to 20.4 mA)
	0 to 20 mA (0 to 20.4 mA)



Attention

Channel 0 through 3 can be configured for voltage or current and support voltage and current ranges defined in Table 1-1

Section 1.3 Input Types and Ranges

The table below lists the input types and their associated ranges.

Table 1-2 (Input Types)

Input Type	Range
E Type Thermocouple	-200 to 1000 °C (-328 to 1832 °F)
J Type Thermocouple	-180 to 1200 °C (-292 to 2192 °F)
K Type Thermocouple	-200 to 1370 °C (-328 to 2498 °F)
T Type Thermocouple	-190 to 400 °C (-310 to 752 °F)
Voltage	0 to 5V (0 to 5.5V)
	1 to 5V (0 to 5.5V)
	+/- 10V (-11 to +11V)
	0 to 10V (0 to 11V)
Current	4 to 20 mA (3.92 to 20.4 mA)
	0 to 20 mA (0 to 20.4 mA)



Attention

Channels 4 and 5 can be configured for current inputs only, and support current input ranges as shown in Table 1-2



Attention

Channels 6 and 7 can be configured for either current or voltage inputs. Current support includes input ranges as shown in Table 1-2. Voltage input ranges include both thermocouple and Voltages as defined in Table 1-2

Section 1.4 Data Formats

For input channels, the data can be configured for:

- Engineering units x1
- Engineering units x10
- Scaled-for-PID
- Raw/proportional data

For output channels, the data can be configured for:

- Engineering units
- Scaled for PID
- Raw/proportional data
- Percent range

Section 1.5 Filter Frequencies

For input channels, the module uses a digital filter that provides high frequency noise rejection for each input signal. The filter for each channel is programmable allowing you to select from four different filter frequencies:

- 4 Hz
- 17 Hz
- 62 Hz
- 470 Hz

Section 1.6 Hardware Features

Channels are wired as differential inputs or single ended outputs. One cold junction compensation (CJC) sensor comes installed under the terminal block (and is not accessible to the user) to enable accurate readings when using thermocouple input types. The CJC sensor compensates for offset voltages introduced into the input signal as a result of the cold-junction where the thermocouple wires come into contact with the terminal block.

Module configuration is done via the controller's programming software. The module configuration is stored in the memory of the controller. Refer to your controller's user manual for more information. The illustration below shows the module's hardware features.

Figure 1-1

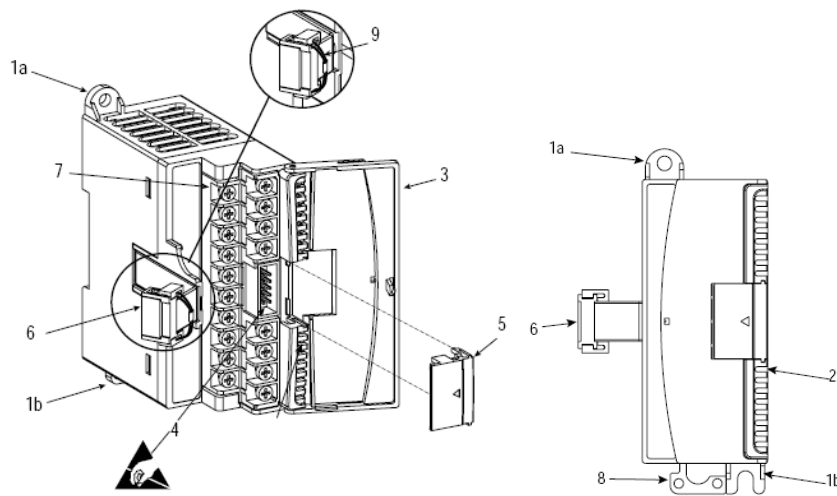

Item	Description
1a	Upper panel mounting tab
1b	Lower panel mounting tab
2	Power diagnostic LED
3	Module door with terminal identification label
4	Bus connector (male)
5	Bus connector cover

- 6 Flat ribbon cable with bus connector (female)
- 7 Terminal block
- 8 DIN rail latch
- 9 Pull loop

1.6.1 LED Indicator

The 1762 combo module uses a single green LED to show operational status of the module. The status LED has the following blink codes:

Blink Code	Description
Blinks rapid green	The module is not in run mode
Solid Green	Startup has completed, all internal tests have passed and the module has received a valid configuration from the PLC
Off	Hardware error

Section 1.7 System Overview

The module communicates to the controller through the bus interface. The module also receives 5 and 24V dc power through the bus interface.

Note: *An external power supply is required for all 2-wire input transmitters.*

1.7.1 Module Power-up

At power-up, the module performs a check of its internal circuits, memory, and basic functions. During this time, the module status LED is blinking rapid green. If no faults are found during power-up diagnostics, the module status LED is turned on.

After power-up checks are complete, the module waits for valid channel configuration data. If an invalid configuration is detected, the module will generate a PLC fault. Once a channel is properly configured and enabled, it continuously converts the input or output data to a value within the range selected for that channel.

Each time a channel is updated by the combo module, that data value is tested for an open-circuit, short-circuit or “input/output data not valid” condition. If such a condition is detected the channel data value will fail to a user defined state defined in the module configuration settings. For more details, refer to Chapter 3.

Using the module’s input and output image table, the controller reads or writes the two’s complement binary data to and from the module. This typically occurs at the end of the program scan or when commanded by the control program. If the controller and the module determine that the data transfer has been made without error, the data is used in the control program.

1.7.2 Module Operation

Input Channels

When the module receives the input from an analog device, the module’s circuitry multiplexes the input into an A/D converter. The converter reads the signal and converts it as required for the type of input. If thermocouples are being utilized, the module

continuously samples the CJC sensor and compensates for temperature changes at the terminal block cold junction, between the thermocouple wire and the terminal connector.

Output Channels

The module's output channel uses a digital-to-analog (D/A) converter to read the digital output data from the controller and convert it to an analog output signal.

See the block diagram below.

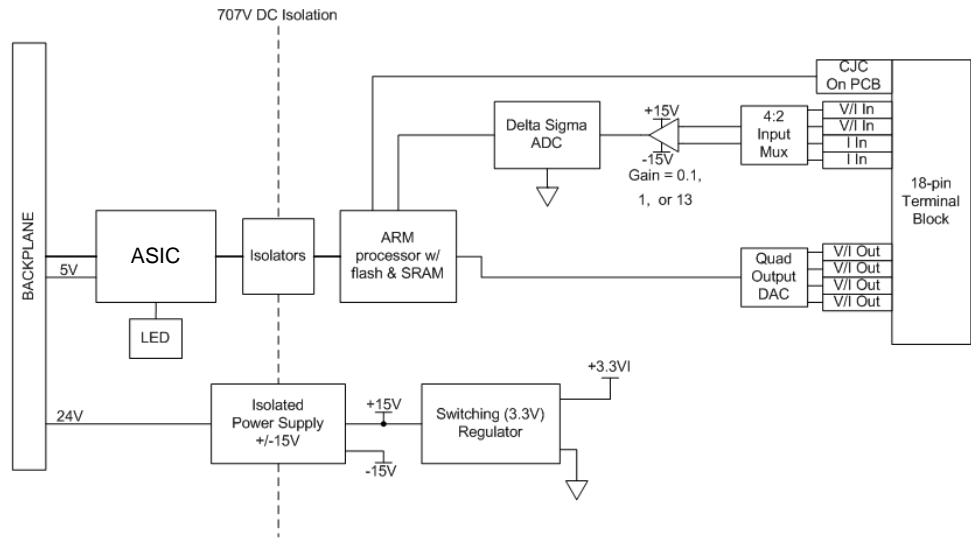

Chapter 2

Installation and Wiring

This chapter will cover:

- Compliance to European union directives
- Power requirements
- General considerations
- Mounting
- Field wiring connections
- Module Indicators

Section 2.1 Compliance to European Union Directives

This product is approved for installation within the European Union and EEA regions. It has been designed and tested to meet the following directives.

2.1.1 EMC Directive

The 1762sc-IF4OF4 module is tested to meet Council Directive 89/336/EEC Electromagnetic Compatibility (EMC) and the following standards, in whole or in part, documented in a technical construction file:

- IEC 61000-6-4 Electromagnetic compatibility (EMC) - Part 6-4: Generic standards - Emission standard for industrial environments
- IEC 61000-6-2 Electromagnetic compatibility (EMC) – Part 6-2: Generic standards – Immunity for industrial environments

This product is intended for use in an industrial environment.

2.1.2 Low Voltage Directive

This product is tested to meet Council Directive 73/23/EEC Low Voltage, by applying the safety requirements of EN 61131-2 Programmable Controllers, Part 2 – Equipment Requirements and Tests. For specific information required by EN61131-2, see the appropriate sections in this publication, as well as the following Allen-Bradley publications:

- *Industrial Automation, Wiring and Grounding Guidelines for Noise Immunity*, publication 1770-4.1
- *Automation Systems Catalog*, publication B113

Section 2.2 Power Requirements

The module receives power through the bus interface from the +5V dc/+24V dc system power supply. The maximum current drawn by the module is shown in the table below.

5 VDC	24 VDC
30 mA	3.0W Max (125mA max at 24V)

Use the table below to determine the maximum number of IF4OF4 modules that can be installed in a MicroLogix system.

Table 2-1

Controller	Max 5V Bus Current	Max 24V Bus Current	Max # of IF4OF4 Modules
ML1100	800	700	4
ML1200 (24pt.)	400	350	3
ML1200 (40pt.)	600	500	3
ML1400 (All)	1500	1500	7

Section 2.3 General Considerations

1762 I/O is suitable for use in an industrial environment when installed in accordance with these instructions. Specifically, this equipment is intended for use in clean, dry environments Pollution degree 2¹ and to circuits not exceeding Over Voltage Category II²(IEC 60664-1)³.

2.3.1 Hazardous Location Considerations

This equipment is suitable for use in Class I, Division 2, Groups A, B, C, D or non-hazardous locations only. The following WARNING statement applies to use in hazardous locations.

¹ Pollution Degree 2 is an environment where, normally, only non-conductive pollution occurs except that occasionally a temporary conductivity caused by condensation shall be expected.

² Over Voltage Category II is the load level section of the electrical distribution system. At this level transient voltages are controlled and do not exceed the impulse voltage capability of the product's insulation.

³ Pollution Degree 2 and Over Voltage Category II are International Electrotechnical Commission (IEC) designations.



EXPLOSION HAZARD

- Substitution of components may impair suitability for Class I, Division 2.
- Do not replace components or disconnect equipment unless power has been switched off or the area is known to be non-hazardous.
- Do not connect or disconnect components unless power has been switched off or the area is known to be non-hazardous.
- This product must be installed in an enclosure.
- All wiring must comply with N.E.C. article 501-4(b).

2.3.2 Prevent Electrostatic Discharge



Electrostatic discharge can damage integrated circuits or semiconductors if you touch analog I/O module bus connector pins or the terminal block on the input module. Follow these guidelines when you handle the module:

- Touch a grounded object to discharge static potential.
- Wear an approved wrist-strap grounding device.
- Do not touch the bus connector or connector pins.
- Do not touch circuit components inside the module.
- If available, use a static-safe work station.
- When it is not in use, keep the module in its static-shield bag.

2.3.3 Remove Power



Remove power before removing or inserting this module. When you remove or insert a module with power applied, an electrical arc may occur. An electrical arc can cause personal injury or property damage by:

- Sending an erroneous signal to your system's field devices, causing unintended machine motion
- Causing an explosion in a hazardous environment

Electrical arcing causes excessive wear to contacts on both the module and its mating connector and may lead to premature failure.

2.3.4 Selecting a Location

Reducing Noise

Most applications require installation in an industrial enclosure to reduce the effects of electrical interference. Analog inputs and outputs are highly susceptible to electrical noise. Electrical noise coupled to the analog inputs or outputs will reduce the performance (accuracy) of the module. Group your modules to minimize adverse effects from radiated electrical noise and heat. Consider the following conditions when selecting a location for the analog module. Position the module:

- Away from sources of electrical noise such as hard-contact switches, relays, and AC motor drives
- Away from modules which generate significant radiated heat. Refer to the module's heat dissipation specification.

In addition, route shielded, twisted-pair analog input and output wiring away from any high voltage I/O wiring.

Section 2.4 Mounting



Attention

Do not remove protective debris strip until after the module and all other equipment near the module is mounted and wiring is complete. Once wiring is complete and the module is free of debris, carefully remove protective debris strip. Failure to remove strip before operating can cause overheating.

2.4.1 Minimum Spacing

Maintain spacing from enclosure walls, wireways, adjacent equipment, etc. Allow 50.8 mm (2 in.) of space on all sides for adequate ventilation, as shown:

Figure 2-1

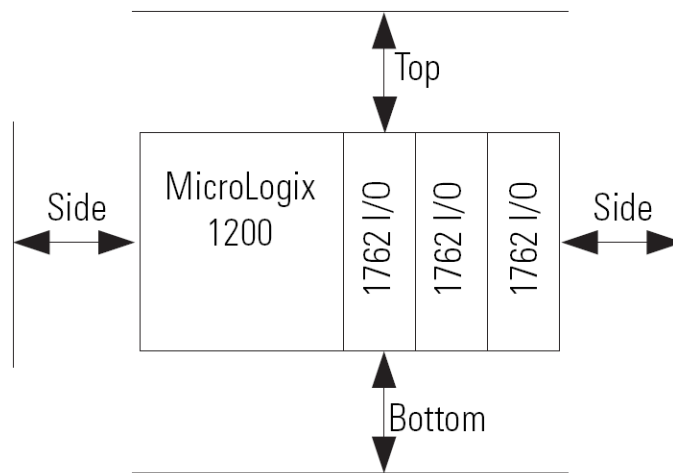

Note: 1762 expansion I/O may be mounted horizontally only.



Attention

During panel or DIN rail mounting of all devices, be sure that all debris (metal chips, wire strands, etc.) is kept from falling into the module. Debris that falls into the module could cause damage when power is applied to the module.

2.4.2 DIN Rail Mounting

The module can be mounted using the following DIN rails: 35 x 7.5 mm (EN 50 022 - 35 x 7.5) or 35 x 15 mm (EN 50 022 - 35 x 15).

Before mounting the module on a DIN rail, close the DIN rail latch. Press the DIN rail mounting area of the module against the DIN rail. The latch will momentarily open and lock into place.

Use DIN rail end anchors (Allen-Bradley part number 1492-EA35 or 1492-EAH35) for environments with vibration or shock concerns.

Figure 2-2

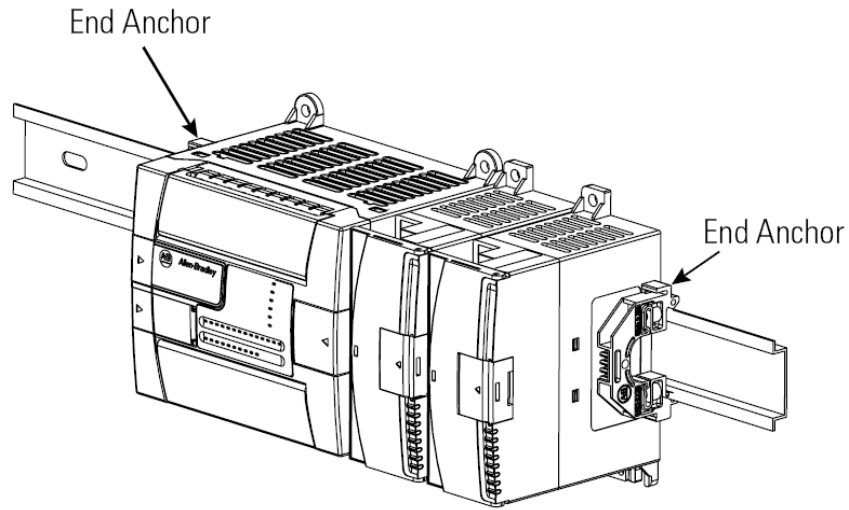

Note: For environments with extreme vibration and shock concerns, use the panel mounting method described below, instead of DIN rail mounting.

2.4.3 Panel Mounting

Use the dimensional template shown below to mount the module. The preferred mounting method is to use two M4 or #8 Pan Head screws per module. M3.5 or #6 Pan Head screws may also be used, but a washer may be needed to ensure a good ground contact. Mounting screws are required on every module.

Figure 2-3

For more than 2 modules: (number of modules - 1) x 40.4 mm (1.59 in.)

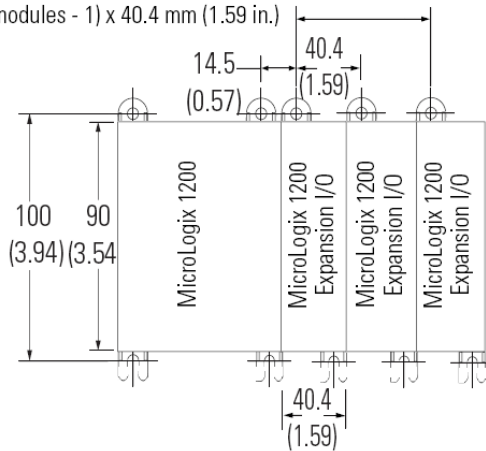

NOTE:
Hole spacing tolerance:
±0.4 mm (0.016 in.).

**Section 2.5
System
Assembly**

The expansion I/O module is attached to the controller or another I/O module by means of a ribbon cable *after* mounting as shown below.

Figure 2-4

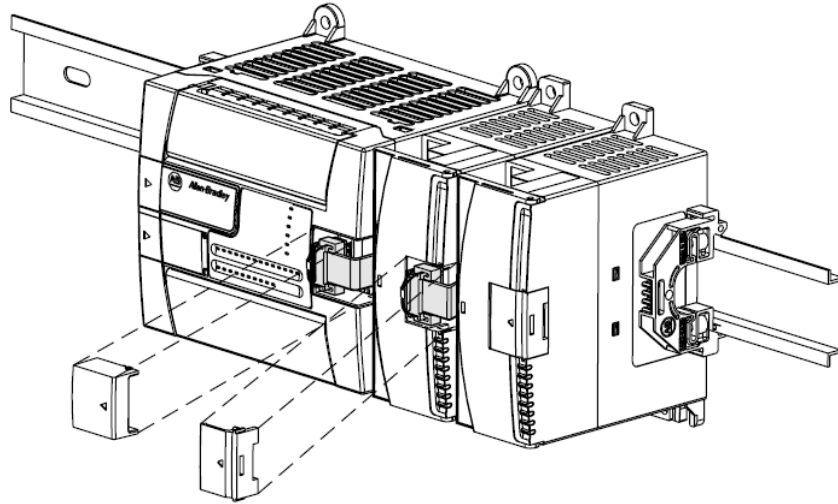

Note: Use the pull loop on the connector to disconnect modules. Do not pull on the ribbon cable.



EXPLOSION HAZARD

- In Class I, Division 2 applications, the bus connector must be fully seated and the bus connector cover must be snapped in place.
- In Class I, Division 2 applications, all modules must be mounted in direct contact with each other as shown on page 2-4. If DIN rail mounting is used, an end stop must be installed ahead of the controller and after the last 1762 I/O module.

Section 2.6 Field Wiring Connections

Consider the following when wiring your system:

General

- Power and input wiring must be in accordance with Class 1, Division 2 wiring methods, Article 501-4(b) of the National Electric Code, NFPA 70, and in accordance with the authority having jurisdiction.
- Input and output channels are not isolated from one another.
- Use Belden™ 8761, or equivalent, shielded wire.
- To ensure optimum accuracy, limit overall cable impedance by keeping a cable as short as possible. Locate the module as close to input devices as the application permits.
- Digital and analog power must be supplied by an Isolated Secondary Limited Energy Low Voltage source.

Inputs

- If multiple power supplies are used with analog inputs, the power supply commons must be connected.
- For a thermocouple, use the shielded, twisted-pair thermocouple extension lead

wires specified by the thermocouple manufacturer. Using the incorrect type of thermocouple extension wire or not following the correct polarity will cause invalid readings.

- The module does not provide loop power for analog inputs. Use a power supply that matches the input transmitter specifications.

Outputs

- Load resistance for a voltage output channel must be equal to or greater than 1K Ω .
- Load resistance for a current output channel must remain between 0 and 500 Ω .

Grounding



The possibility exists that a grounded or exposed thermocouple can become shorted to a potential greater than that of the thermocouple itself. Due to possible shock hazard, take care when wiring grounded or exposed thermocouples.



USE SUPPLY WIRES SUITABLE FOR 10°C ABOVE SURROUNDING AMBIENT



UTILISER DES FILS D'ALIMENTATION QUI CONVIENNENT A UNE TEMPERATURE DE 10°C AU-DESSUS DE LA TEMPERATURE AMBIANTE

- This product is intended to be mounted to a well-grounded mounting surface such as a metal panel. Additional grounding connections from the module's mounting tabs or DIN rail (if used) are not required unless the mounting surface cannot be grounded.
- Under normal conditions, the drain wire (shield) should be connected to the metal mounting panel (earth ground). Keep shield connection to earth ground as short as possible.
- Ground the shield drain wire at one end only. The typical location is as follows:
 - For grounded thermocouples or millivolt sensors, this is at the sensor end.
 - For insulated/ungrounded thermocouples, this is at the module end. Contact your sensor manufacturer for additional details.
- Refer to Industrial Automation Wiring and Grounding Guidelines, Allen-Bradley publication 1770-4.1, for additional information.

Noise Prevention

- Route field wiring away from any other wiring and as far as possible from sources of electrical noise, such as motors, transformers, contactors, and ac devices. As a general rule, allow at least 15.2 cm (6 in.) of separation for every 120V of power.
- Routing field wiring in a grounded conduit can reduce electrical noise.
- If field wiring must cross ac or power cables, ensure that they cross at right angles.

- To limit the pickup of electrical noise, keep thermocouple and millivolt signal wires as far as possible from power and load lines.
- If noise persists for a device, try grounding the opposite end of the cable shield or ground both ends of the shield.

2.6.1 Wiring Diagram

Refer to the following wiring diagrams for field wiring connections.

Figure 2-5 (Wiring Diagram)

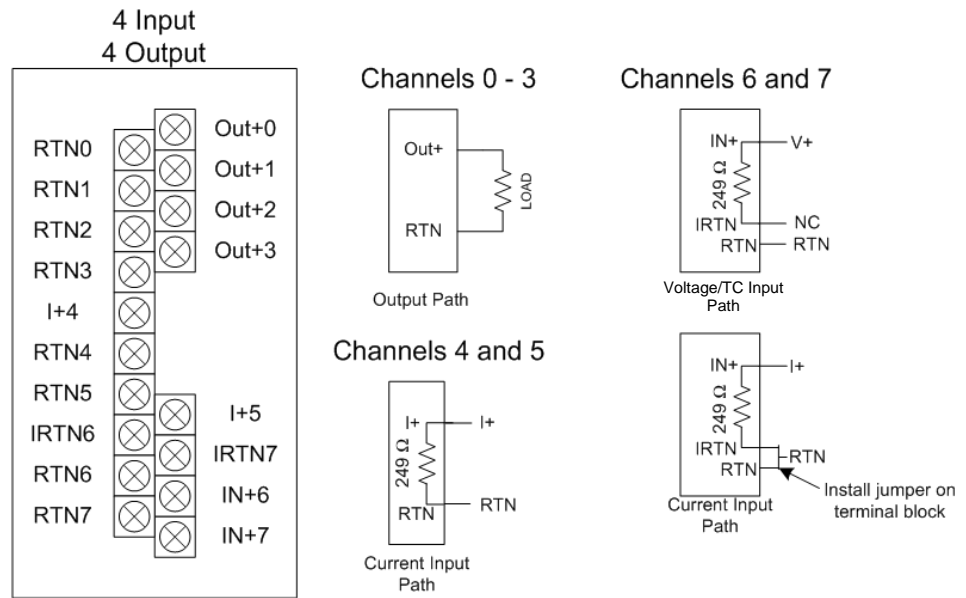

2.6.2 Wiring the Finger-Safe Terminal Block

Figure 2-6

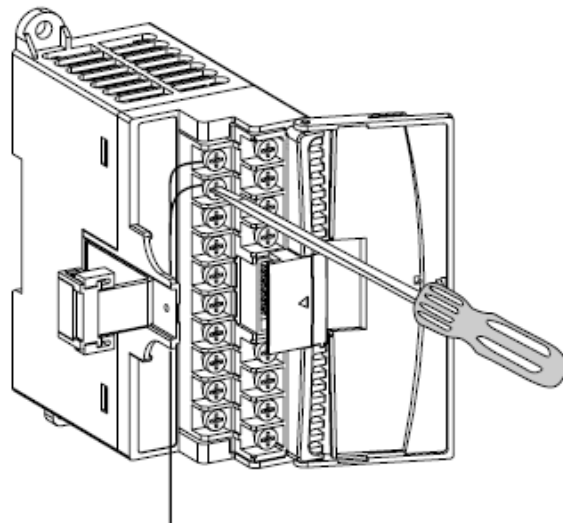



Attention

Be careful when stripping wires. Wire fragments that fall into a module could cause damage when power is applied. Once wiring is complete, ensure the module is free of all metal fragments.

When wiring the terminal block, keep the finger-safe cover in place.

- 1) Refer to section 2.6.1 for proper field wiring connections.
- 2) Route the wire under the terminal pressure plate. You can use the stripped end of the wire or a spade lug. The terminals will accept a 6.35 mm (0.25 in.) spade lug. See Figure 2-6.
- 3) Tighten the terminal screw making sure the pressure plate secures the wire. Recommended torque when tightening terminal screws is 0.904 Nm (8 in-lbs).
- 4) After wiring is complete, remove the debris shield.

2.6.3 Terminal Door Label

A removable, write-on label is provided with the module. Remove the label from the door, mark your unique identification of each terminal with permanent ink, and slide the label back into the door. Your markings (ID tag) will be visible when the module door is closed. See figure below.

Figure 2-7 (Door Label)

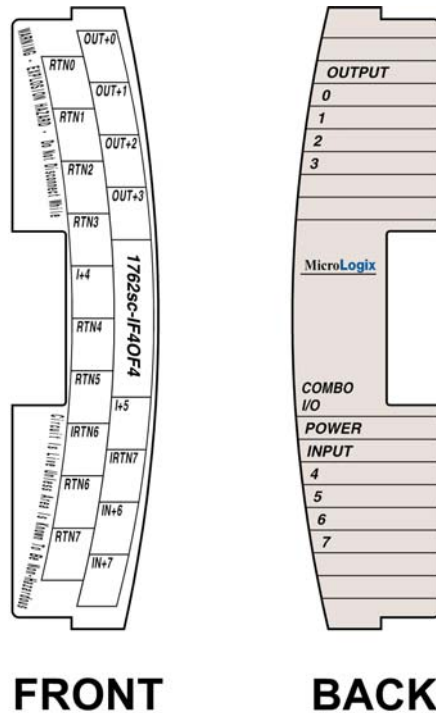

Section 2.7 Module Indicators

The 1762 combo module uses a single green LED to show operational status of the module. The table below shows the possible blink codes.

Blink Code	Description
Blinks rapid green	The module is not in run mode
Solid Green	Startup has completed, all internal tests have passed and the module has received a valid configuration from the PLC
Off	Hardware error

Chapter 3

Configuring the 1762sc-IF4OF4 Using RSLogix 500

This chapter covers the following subjects:

- Things you should know
- Module memory map
- Add module to Logix 500
- Module configuration
- Reading input data
- Module update time

Section 3.1 Things You Should Know

This chapter describes how to configure the IF4OF4 module for the MicroLogix 1100, 1200 and 1400 system using RSLogix 500 programming software.

Section 3.2 Module Memory Map

The module uses 8 input words and 8 output words for input data and configuration. The following figure describes the data mapping for the module.

Figure 3-1 (Module Memory Map)

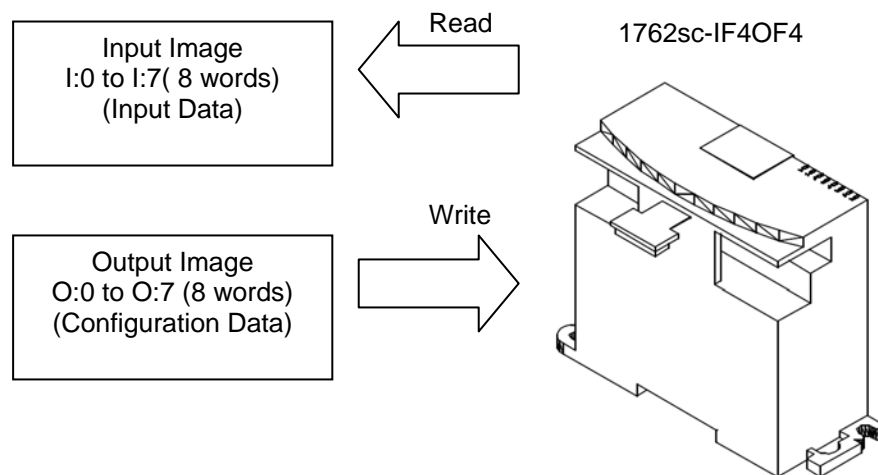

Section 3.3 Add Module to Logix 500

The following procedure describes how to add the IF4OF4 module to the RSLogix 500 programming software.

- 1.) Create a new RSLogix 500 project and select either a Micro 1100, 1200, or 1400 processor.
- 2.) Double-click “I/O Configuration” from the project tree.

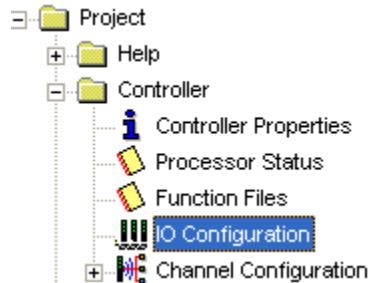

- 3.) Select the first empty slot and then double-click the “Other—Requires I/O Card Type ID” option, from the I/O configuration screen.

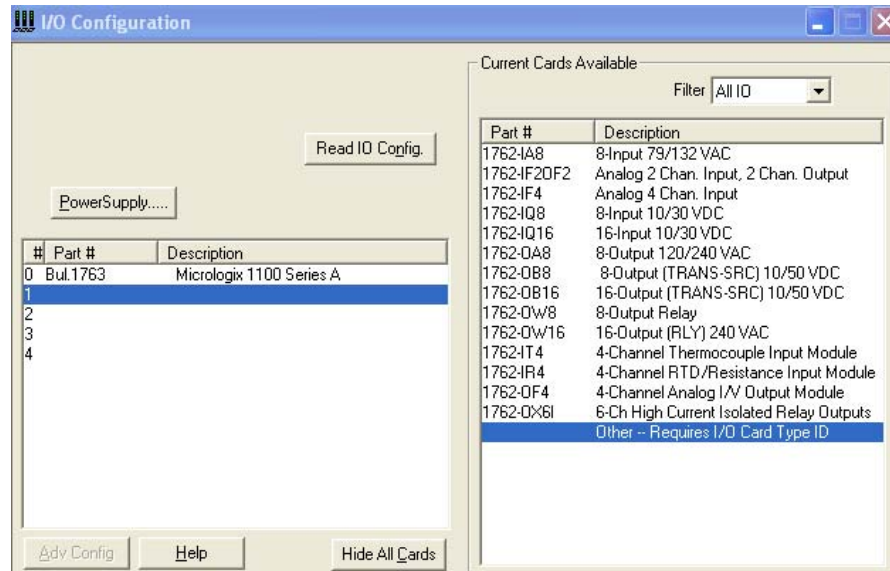

- 4.) Enter the module profile data as shown in the figure below and click “OK”.

"Other" type IO card

Vendor ID:

Product Type:

Product Code:

Series/Major Rev/Minor Rev:

Input Words: Input Bits:

Output Words: Output Bits:

Extra Data Length:

Ignore Configuration Error:

5.) Repeat steps 1 through 4 for additional modules.

Section 3.4 Module Configuration

The IF4OF4 is configured using the output data table within RSLogix 500.

3.4.1 Output Data File (Configuration Data)

The output data file is used to configure the advanced settings of the module including input type, output type, data format, filter settings, etc. Use the addressing scheme below to locate the 8 output words needed to configure the module.

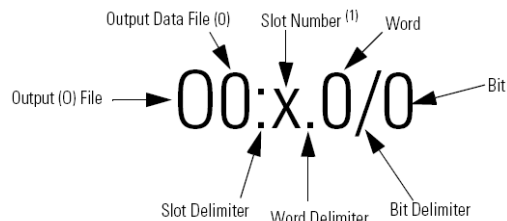

(1) I/O located on the controller (embedded I/O) is slot 0. I/O added to the controller (expansion I/O) begins with slot 1.

The table below shows the general layout for the 8 output words used for configuration.

Table 3-1 (Output File)

Register	Function
Output File (Used for Module Configuration)	
O:e.0	Channel 0 Data Word
O:e.1	Channel 1 Data Word
O:e.2	Channel 2 Data Word
O:e.3	Channel 3 Data Word
O:e.4	Low byte: Channel 0 Configuration Register (Output)

Register	Function
Output File (Used for Module Configuration)	
	High byte: Channel 1 Configuration Register (Output)
O:e.5	Low byte: Channel 2 Configuration Register (Output) High byte: Channel 3 Configuration Register (Output)
O:e.6	Low byte: Channel 4 Configuration Register (Input) High byte: Channel 5 Configuration Register (Input)
O:e.7	Low byte: Channel 6 Configuration Register (Input) High byte: Channel 7 Configuration Register (Input)

3.4.2 Output Channel Configuration (Channels 0 through 3)

The table below describes the configuration options for analog output channels 0 through 3.

Table 3-2 (Configuration for Output Channels 0 through 3)

To Select		Make these bit settings							
		7	6	5	4	3	2	1	0
Output Type	4 to 20 mA						0	0	0
	0 to 20 mA						0	0	1
	-10 to 10 V						0	1	0
	0 to 10 V						0	1	1
	1 to 5 V						1	0	0
	0 to 5 V						1	0	1
	Reserved						1	1	0
Channel Disabled						1	1	1	
Data Format	Scaled for PID				0	0			
	Engineering Units				0	1			
	Percent Range				1	0			
	Raw/Proportional Data				1	1			
Unused		0	0	0					

Table 3-3 lists the number of counts for each of the supported input channel data ranges.

Table 3-3 (Output Channel Data Ranges)

Output Range	Output Value	Condition	Raw/Prop	EU	PID	% FS
4..20mA	20.40 mA	High Limit	32767	20400	16793	10250
	20.00 mA	High Range	31176	20000	16383	10000
	4.00 mA	Low Range	-32450	4000	0	0
	3.92 mA	Low Limit	-32768	3920	-82	-50
0..20mA	20.40 mA	High Limit	32767	20400	16711	10200
	20.00 mA	High Range	31482	20000	16383	10000
	0.00 mA	Low Limit/Range	-32768	0	0	0
+/-10V	11.00 V dc	High Limit	32767	11000	17202	11000
	10.00 V dc	High Range	29788	10000	16383	10000
	-10.00 V dc	Low Range	-29788	-10000	0	-10000

Output Range	Output Value	Condition	Raw/Prop	EU	PID	% FS
0 to 5V	-11.00 V dc	Low Limit	-32768	-11000	-819	-11000
	5.50 V dc	High Limit	32767	5500	18021	11000
	5.00 V dc	High Range	26809	5000	16383	10000
	0.00 V dc	Low Range	-32768	0	0	0
0 to 10V	0.00 V dc	Low Limit	-32768	0	0	0
	11.00 V dc	High Limit	32767	11000	18021	11000
	10.00 V dc	High Range	26809	10000	16383	10000
	0.00 V dc	Low Range	-32768	0	0	0
1 to 5V	0.00 V dc	Low Limit	-32768	0	0	0
	5.50 V dc	High Limit	32767	5500	18431	11250
	5.00 V dc	High Range	26809	5000	16383	10000
	1.00 V dc	Low Range	-20853	1000	0	0
	0.00 V dc	Low Limit	-32768	000	-4096	-2500

3.4.3 Input Channel Configuration (Channels 4 and 5)

Channels 4 and 5 are current only channels. The table below describes the configuration options for channels 4 and 5.

Table 3-4 (Configuration for Input Channels 4 and 5)

To Select		Make these bit settings								
		7	6	5	4	3	2	1	0	
Filter Frequency (Ignored if Display CJC)	17 Hz								0	0
	4 Hz								0	1
	62 Hz								1	0
	470 Hz								1	1
Data Format	Engineering Units X1					0	0			
	Engineering Units X10					0	1			
	Raw/Proportional Data					1	0			
	Scaled for PID					1	1			
Input Type	4 to 20 mA			0	0					
	0 to 20 mA			0	1					
	Reserved			1	0					
	Channel Disabled			1	1					
Open Circuit (For Module) ⁴	Upscale		0							
	Zero		1							
Temperature Scale (For Module) ⁴	Deg C	0								
	Deg F	1								

⁴ This is a module wide setting which is only recognized within the configuration for Channel 4. The corresponding bit in Channel 5 is ignored.

3.4.4 Input Channel Configuration (Channels 6 and 7)

Channels 6 and 7 can be configured for current or voltage, including thermocouple inputs. The following table describes the configuration options for channels 6 and 7.

Table 3-5 (Configuration for Input channels 6 and 7)

To Select		Make these bit settings							
		7	6	5	4	3	2	1	0
Filter Frequency (Ignored if Display CJC)	17 Hz							0	0
	4 Hz						0	1	
	62 Hz						1	0	
	470 Hz						1	1	
Data Format	Engineering Units X1					0	0		
	Engineering Units X10					0	1		
	Raw/Proportional Data					1	0		
	Scaled for PID					1	1		
Input Type	4 to 20 mA	0	0	0	0				
	0 to 20 mA	0	0	0	1				
	-10 to 10 V	0	0	1	0				
	0 to 10 V	0	0	1	1				
	1 to 5 V	0	1	0	0				
	0 to 5 V	0	1	0	1				
	Type J TC	0	1	1	0				
	Type K TC	0	1	1	1				
	Type E TC	1	0	0	0				
	Type T TC	1	0	0	1				
	Type J TC CJC Disabled	1	0	1	0				
	Type K TC CJC Disabled	1	0	1	1				
	Type E TC CJC Disabled	1	1	0	0				
	Type T TC CJC Disabled	1	1	0	1				
	Display CJC channel temp	1	1	1	0				
Channel Disabled	1	1	1	1					

Table 3-6 lists the number of counts for each of the supported input channel data ranges.

Note: *The engineering unit data formats represent real engineering temperature units provided by the module to the controller. The raw/proportional counts, scaled-for-PID and percent of full-scale data formats may yield the highest effective resolutions, but may also require that you convert channel data to real engineering units in your control program.*

Table 3-6 (Input Channel Data Ranges)

Input Range	Input Value	Condition	EU x1	EU x10	Raw Prop	PID
J Thermocouple	1200.00 deg C	High Limit	12000	1200	32767	16383
	1200.00 deg C	High Range	12000	1200	32767	16383
	-180.00 deg C	Low Range	-1800	-180	-32768	0
	-180.00 deg C	Low Limit	-1800	-180	-32768	0
K Thermocouple	1370.00 deg C	High Limit	13700	1370	32767	16383
	1370.00 deg C	High Range	13700	1370	32767	16383
	-200.00 deg C	Low Range	-2000	-200	-32768	0
	-200.00 deg C	Low Limit	-2000	-200	-32768	0

Input Range	Input Value	Condition	EU x1	EU x10	Raw Prop	PID
E Thermocouple	1000.00 deg C	High Limit	10000	1000	32767	16383
	1000.00 deg C	High Range	10000	1000	32767	16383
	-200.00 deg C	Low Range	-2000	-200	-32768	0
T Thermocouple	400.00 deg C	High Limit	4000	400	32767	16383
	400.00 deg C	High Range	4000	400	32767	16383
	-190.00 deg C	Low Range	-1900	-190	-32768	0
0..5V	5.50 V dc	High Limit	5500	550	32767	18201
	5.00 V dc	High Range	5000	500	32767	16383
	0.00 V dc	Low Range	0	0	-32768	0
1..5V	0.00 V dc	Low Limit	0	0	-32768	0
	5.50 V dc	High Limit	5500	550	32767	18431
	5.00 V dc	High Range	5000	500	32767	16383
+/-10V	1.00 V dc	Low Range	1000	100	-32768	0
	0.00 V dc	Low Limit	0	0	-32768	-4096
	11.00 V dc	High Limit	11000	1100	32767	17202
0..10V	10.00 V dc	High Range	10000	1000	32767	16383
	0.00 V dc	Low Range	0	0	-32768	0
	0.00 V dc	Low Limit	0	0	-32768	0
4..20mA	20.40 mA	High Limit	20400	2040	32767	16793
	20.00 mA	High Range	20000	2000	32767	16383
	4.00 mA	Low Range	4000	400	-32768	0
0..20mA	3.92 mA	Low Limit	3920	392	-32768	-82
	20.40 mA	High Limit	20400	2040	32767	16711
	20.00 mA	High Range	20000	2000	32767	16383
CJC	0.00 mA	Low Range	0	0	-32768	0
	0.00 mA	Low Limit	0	0	-32768	0
	85.00 deg C	High Limit	8500	850	32767	16383
CJC	85.00 deg C	High Range	8500	850	32767	16383
	-25.00 deg C	Low Range	-2500	-250	-32768	0
	-25.00 deg C	Low Limit	-2500	-250	-32768	0

Section 3.5

Read Input Data

The input data file contains module status information and analog input data for each of the four input channels. Analog input data is read for each channel, converted to a scaled digital value, and stored in the input file. Use the addressing scheme below to locate the 8 input words used for channels 0 through 7, respectively.

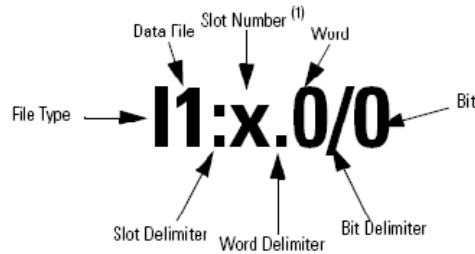

(1) I/O located on the controller (embedded I/O) is slot 0. I/O added to the controller (expansion I/O) begins with slot 1.

The layout for the input file is shown below.

Table 3-7 (Input Data File Layout)

	Word	Bits															
		15	14	13	12	11	10	9	8	7	6	5	4	3	2	1	0
General Status	I:e.0	-	-	-	-	-	-	-	-	S7	S6	S5	S4	S3	S2	S1	S0
Output Status	I:e.1	-	LD3	U3	O3	-	LD2	U2	O2	-	LD1	U1	O1	-	LD0	U0	O0
Input Status	I:e.2	-	OC7	U7	O7	-	OC6	U6	O6	-	OC5	U5	O5	-	OC4	U4	O4
CJC Temperature	I:e.3	16 Bit Word															
Input Channel 4 Data	I:e.4	16 Bit Word															
Input Channel 5 Data	I:e.5	16 Bit Word															
Input Channel 6 Data	I:e.6	16 Bit Word															
Input Channel 7 Data	I:e.7	16 Bit Word															

- = Not used: Bit set to 0.

S<x> = General status bit: If a bit is set (1) then there is an error associated with that channel (i.e. under/over range).

U<x> = Under range flag bits: Applies to all input/output types.

Inputs:

When set to 1, indicates input signal is below the value in the “Low Range” column indicated by the table above. However, the module will continue to convert analog data to the minimum “Low Limit” value. Bit is automatically reset (0) by the module when the under range condition clears.

For input data types 0-20mA, 0-10V, and 0-5V, the under range flag bits will be set when the data value is 0.

Outputs:

When set to 1, indicates the output word value set by the user is below the “Low Range” value (depending on the data format). The channel will

output voltage or current (depending on the output type) down to the “Low Limit” value.

O<x> = Over range flag bits: Applies to all input/output types.

Inputs:

When set to 1 indicates input signal is above the “High Range” value. Module will continue to convert analog data to the maximum “High Limit” value. Bit is automatically reset (0) by the module when the over range condition clears.

Outputs:

When set to 1, indicates the output word value set by the user is above the ”High Range” value (determined by the format). The channel will output voltage or current (depending on the output type) up to the “High Limit” value.

LD<x> = Load Error: This applies only to output channels. If the channel is configured for voltage, this bit indicates a short circuit. If configured for current, an open circuit is indicated. The error bit is cleared (0) at the time the condition is cleared.

OC<x> = Open Circuit: This bit is only valid for 1-5V, 4-20mA ranges. When set to 1, an open circuit has been detected.

Inputs:

Open circuit detection is only available for input channels configured for 4-20mA current or 1-5V voltage. The remainder of the input ranges will float near 0V or 0mA when an open wire condition occurs. For each input channel, the user is given the option of reporting upscale or 0 (see configuration words). For 4-20mA range, an open wire condition will be set for any value less than 2.0mA. For 1-5V range, an open wire condition will be set for any voltage below 0.5V. Thermocouple ranges will display appropriate temperatures for an input voltage near 0V.

Note: A special case exists when channels 6 or 7 are configured to display CJC temperature. If either channel is configured to display the CJC temperature, the associated OC bit will indicate an open-circuit condition, if one exists, for the CJC sensor itself.

Outputs:

Open circuit detection is available for output channels in current mode. For current outputs, open wire may not be detected when the output is driven at or near zero.

Note: Input word 3 will always display the raw CJC temperature in degrees C, Engineering units, and so no channel configuration is needed.

Section 3.6 Module Update Time

The module update time is determined by the number of input channels enabled and by the filter frequency selected for each channel.

ADC Filter Frequency	Filter Frequency (-3dB point)	Conversion Time	Module update
470 Hz	109 Hz	20 ms	= sum of conversion times for each enabled channels
62 Hz	14 Hz	45 ms	
17 Hz	4 Hz	135 ms	
4Hz	1 Hz	495 ms	

Appendix A

Module Specifications

General Specifications

<i>Specification</i>	<i>Value</i>												
Dimensions	90 mm (height) x 87 mm (depth) x 40 mm (width) height including mounting tabs is 110 mm 3.54 in. (height) x 3.43 in. (depth) x 1.58 in. (width) height including mounting tabs is 4.33 in.												
Approximate Shipping Weight (with carton)	281g (0.619 lbs.)												
Storage Temperature	-40°C to +85°C (-40°F to +185°F)												
Operating Temperature	-20°C to +60°C (-4°F to +140°F)												
Operating Humidity	5% to 95% non-condensing												
Operating Altitude	2000 meters (6561 feet)												
Vibration	Operating: 10 to 500 Hz, 5G, 0.030 in. max. peak-to-peak												
Shock	Operating: 30G												
Bus Current Draw (max.)	30 mA at 5V dc Max 3.0W Max (125mA max at 24V)												
Heat Dissipation	3.0W Total Max												
Resolution	16 bits (Integer Format)												
Channel Update Time	<table border="1"> <thead> <tr> <th>Filter Setting</th> <th>Conversion Time</th> <th>Module Update time⁵</th> </tr> </thead> <tbody> <tr> <td>470 Hz</td> <td>20 ms</td> <td rowspan="4">= Conversion time * (1+ number of enabled channels)</td> </tr> <tr> <td>62 Hz</td> <td>45 ms</td> </tr> <tr> <td>17 Hz</td> <td>135 ms</td> </tr> <tr> <td>4 Hz</td> <td>495 ms</td> </tr> </tbody> </table>	Filter Setting	Conversion Time	Module Update time ⁵	470 Hz	20 ms	= Conversion time * (1+ number of enabled channels)	62 Hz	45 ms	17 Hz	135 ms	4 Hz	495 ms
	Filter Setting	Conversion Time	Module Update time ⁵										
	470 Hz	20 ms	= Conversion time * (1+ number of enabled channels)										
	62 Hz	45 ms											
	17 Hz	135 ms											
4 Hz	495 ms												
Input Group to System Isolation	Channel to Rack: 707 VDC for 1 minute Optical & magnetic Channel to Channel: Input channels are differential as long as all pins are within +/- 13 V dc of the output return lines.												
Module Power LED	On: indicates power is applied and module not faulted.												
Recommended Cable Specification	Belden™ 8761 (shielded)												
Vendor I.D.	58												
Product Type	10												
Product Code	22												
Agency Certification	C-UL listed (under CSA C22.2 No. 142) UL 508 listed CE compliant for all applicable directives												

⁵ The module update time is purely the sum of conversion times for each enabled channels. The extra addition of 1 is not necessary.

<i>Specification</i>	<i>Value</i>
Hazardous Environment Class	Class I, Division 2, Hazardous Location, Groups A, B, C, D (ISA 12.12.01, C-UL under CSA C22.2 No. 213) Operating Temperature Code T4a
Radiated and Conducted Emissions	EN55011
Electrical /EMC:	The module has passed testing at the following levels:
ESD Immunity (IEC61000-4-2)	4 kV contact, 8 kV air, 4 kV indirect
Radiated Immunity (IEC61000-4-3)	10 V/m, 80 to 1000 MHz, 80% amplitude modulation, +900 MHz keyed carrier
Fast Transient Burst (IEC61000-4-4)	2 kV, 5 kHz
Surge Immunity (IEC61000-4-5)	1 kV galvanic gun
Conducted Immunity (IEC61000-4-6)	10V, 0.15 to 80 MHz ⁶

Input Specifications

Specification	Value	
Number of Inputs	2 Current only and 2 Current/(Voltage or Thermocouple)	
A/D Converter Type	Delta Sigma	
Common Mode Rejection	75 dB for 4 Hz & 17 Hz Filters	
Normal Mode Rejection	4 Hz Filter	74dB minimum at 50 and 60 Hz
	17 Hz Filter	65dB minimum at 50 and 60 Hz
	62 Hz Filter	First notch at 31Hz, typically 30dB
	470 Hz Filter	First notch at 237 Hz, typically 35dB
Non-linearity (in percent full scale)	±0.1%	
Input Impedance	Current Terminal: 249Ω	
Current Input Protection	±42 mA	
Voltage Input Protection	±28 V ⁷	

⁶ Conducted Immunity frequency range may be 150 kHz to 30 MHz if the Radiated Immunity frequency range is 30 MHz to 2700 MHz.

⁷ The input voltage on any input pin must be within ±13VDC of the output return lines for normal operation.

<i>Specification</i>	<i>Value</i>
Calibrated Accuracy	
Thermocouple Inputs	<p>Linearization per ITS-90</p> <p>System accuracy at 25°C (4 and 17 Hz filters):</p> <p>Type J (-180°C to 1200°C): ±1.0 degrees C maximum</p> <p>Type K (-200°C to 1370°C): ±2.0 degrees C maximum</p> <p>Type E (-200°C to 1000°C): ±1.0 degrees C maximum</p> <p>Type T (-190°C to 400°C): ±2.0 degrees C maximum</p> <p>System accuracy at -20-60 C (4 and 17 Hz filters):</p> <p>Type J (-180°C to 1200°C): ±5.0 degrees C maximum</p> <p>Type K (-200°C to 1370°C): ±6.0 degrees C maximum</p> <p>Type E (-200°C to 1000°C): ±4.5 degrees C maximum</p> <p>Type T (-190°C to 400°C): ±4.0 degrees C maximum</p> <p>The above limits do not include the cold junction compensation or thermocouple sensor errors.</p>
CJC Profile Accuracy	± 4.0 degrees C maximum Temperature correlation to target terminal
CJC Sensor Accuracy	± 1.0 degrees C maximum Reading/Conversion of the sensor -20 to 80C input values
CJC Repeatability	± 0.5 degrees C maximum for -20-80C input values
Voltage Inputs	<p>System accuracy at 25° C (4 and 17 Hz filters):</p> <p>± 3 mV maximum for 0-5V inputs</p> <p>± 3 mV maximum for 1-5V inputs</p> <p>± 10 mV maximum for 0-10V inputs</p> <p>± 10 mV maximum for ±10V inputs</p> <p>System accuracy at -20-60° C (4 and 17 Hz filters):</p> <p>± 6 mV maximum for 0-5V inputs</p> <p>± 6 mV maximum for 1-5V inputs</p> <p>± 20 mV maximum for 0-10V inputs</p> <p>± 20 mV maximum for ±10V inputs</p>

<i>Specification</i>	<i>Value</i>
Current Inputs	System accuracy at 25° C (4 and 17 Hz filters): ± 20 uA maximum for 0-20 mA inputs ± 20 uA maximum for 4-20 mA inputs System accuracy at -20-60°C (4 and 17 Hz filters): ± 50 uA maximum for 0-20 mA inputs ± 50 uA maximum for 4-20 mA inputs

Input Repeatability

Input Repeatability (at 25°C)	4Hz Filter	17Hz Filter	62 and 470Hz Filters typical values ⁸
Thermocouples			
Type J	± 0.3 °C	±0.3 °C	Not Recommended
Type K	± 0.4 °C	±0.4 °C	Not Recommended
Type T	± 0.3 °C	±0.3 °C	Not Recommended
Type E	± 0.3 °C	±0.3 °C	Not Recommended
Voltage Inputs	± 1 mV	± 2 mV	± 4 mV
Current Inputs	± 2 µA	± 2 µA	± 6 µA

Output Specifications

Specification	Description
Number of Outputs	4 channels of current or voltage
Accuracy - Voltage Outputs	System accuracy at 25° C: ± 20 mV maximum System accuracy at -20-60°C: ± 50 mV maximum
Accuracy - Current Outputs	System accuracy at 25° C: ± 50 uA maximum System accuracy at -20-60°C: ± 75 uA maximum
Output Resolution	
Voltage Output	400µV per bit average when using RAW format in ±10V range and 0-10V range 185µV per bit average when using RAW format in 0-5 or 1-5V ranges
Current Output	380nA per bit when using RAW format for all current ranges
Differential Nonlinearity	1 LSB (see resolution for LSB size)
Output Ripple	<15mV ripple for voltage or current
Output Impedance	Current: >1Megohm, Voltage: <1 ohm (MRD)
Output Load	Current: 0 ohm min, 500 ohm max, Voltage: >=1k ohm at 10V output (10 mA), includes wire resistance.

⁸ These filters do not reject 50/ 60 Hz. Repeatability for these filters is strongly dependent on how much 50/60Hz noise is in the system.

Specification	Description
Maximum Output Inductive and Capacitive Load	0.1mH 1 μ F
Output Settling Time	<1ms to 63% of full scale
Output Channel glitch)	Current mode = $< \pm 1V$ for 20ms at maximum load Voltage mode = $< \pm 0.4V$ for 20ms and $< \pm 1V$ for 1.5ms with 1k ohm load
Output Protection	$\pm 24V$ @25dec C for 1 minute on any channel, with any range and value
Output Short Circuit Protection	Yes, continuous. (IEC 1131-2 requirement) with any range and value

Index

A

Addressing · 3-3, 3-8

B

block diagram · 1-5

C

Configuration · 3-3

D

Data Format · 1-2
Door Label · 2-9

E

EMC Directive · 2-1

F

Filter Frequencies · 1-3

G

Grounding · 2-7

H

Hazardous Location · 2-2

I

Input Channel
Data Ranges · 3-6
Input Data · 3-8

Input Type · 1-1

L

LED · 1-4, 2-9
Low Voltage Directive · 2-1

M

Memory Map · 3-1
Module Update Time · 3-9
Mounting
DIN · 2-4
Panel · 2-5

N

Noise · 2-3, 2-7

O

Output Type · 1-1

P

Power Requirements · 2-1
power-up · 1-4

S

Slot number · 3-3
Slot Number · 3-8
Spacing
Minimum · 2-4

W

Wiring Diagram · 2-8

Getting Technical Assistance

Note that your module contains electronic components which are susceptible to damage from electrostatic discharge (ESD). An electrostatic charge can accumulate on the surface of ordinary plastic wrapping or cushioning material. **In the unlikely event that the module should need to be returned to Spectrum Controls, please ensure that the unit is enclosed in approved ESD packaging (such as static-shielding / metalized bag or black conductive container).** Spectrum Controls reserves the right to void the warranty on any unit that is improperly packaged for shipment.

RMA (Return Merchandise Authorization) form required for all product returns.

For further information or assistance, please contact your local distributor, or call the Spectrum Controls technical Support at:

USA - 425-746-9481

Declaration of Conformity

Available upon request



©2009, Spectrum Controls, Inc. All rights reserved. Specifications subject to change without notice.
The Encompass logo and ControlLogix are trademarks of Rockwell Automation.

Corporate Headquarters

Spectrum Controls Inc.
P.O. Box 5533
Bellevue, WA 98006 USA
Fax: 425-641-9473
Tel: 425-746-9481

Web Site: www.spectrumcontrols.com
E-mail: spectrum@spectrumcontrols.com

