

Serial No.	H-A019-E-9
------------	------------

Butterfly Valve Type 55・Type 55IS

Contents

Electric Actuated Type S

Type 55 50-250mm (2"-8")

Type 55IS 50-150mm (2"-6")

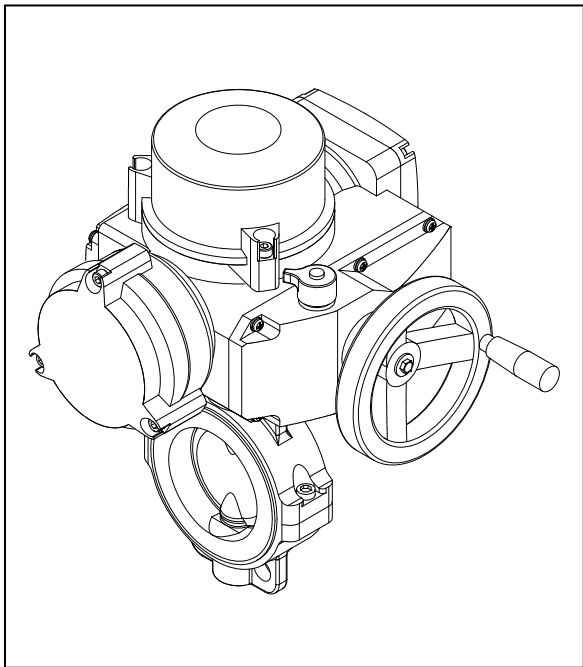

User's Manual

- (1) Be sure to read the following warranty clauses of our product 1
- (2) General operating instructions 2
- (3) General instructions for transportation, unpacking and storage 3
- (4) Name of parts 4
- (5) Working pressure vs. temperature 5
- (6) Specifications of actuator 6
 Wiring diagram 7
- (7) Installation procedure 8
- (8) Support setting procedure 11
- (9) Electric wiring procedure 12
- (10) Operating procedure 13
 Manual operating procedure 14
 Motor-driven operating procedure 14
- (11) Disassembly and assembly procedure 15
- (12) Adjustment limit switch 16
- (13) Inspection items 17
- (14) Troubleshooting 18
- (15) Handling of residual and waste materials 19





This user's guide contains information important to the proper installation, maintenance and safe use of an ASAHI AV Product. Please store this manual in an easily accessible location.

<Warning & Caution Signs>

 Warning	This symbol reminds the user to take caution due to the potential for serious injury or death.
 Caution	This symbol reminds the user to take caution due to the potential for damage to the valve if used in such a manner.

<Prohibited & Mandatory Action Signs>

	Prohibited: When operating the valve, this symbol indicates an action that should not be taken.
	Mandatory action: When operating the valve, this symbol indicates mandatory actions that must be adhered to.

(1) Be sure to read the following warranty clauses of our product

- Always observe the specifications of and the precautions and instructions on using our product.
- We always strive to improve product quality and reliability, but cannot guarantee perfection. Therefore, should you intend to use this product with any equipment or machinery that may pose the risk of serious or even fatal injury, or property damage, ensure an appropriate safety design or take other measures with sufficient consideration given to possible problems. We shall assume no responsibility for any inconvenience stemming from any action on your part without our written consent in the form of specifications or other documented approval.
- The related technical documents, operation manuals, and other documentation prescribe precautions on selecting, constructing, installing, operating, maintaining, and servicing our products. For details, consult with our nearest distributor or agent.
- Our product warranty extends for one and a half years after the product is shipped from our factory or one year after the product is installed, whichever comes first. Any product abnormality that occurs during the warranty period or which is reported to us will be investigated immediately to identify its cause. Should our product be deemed defective, we shall assume the responsibility to repair or replace it free of charge.
- Any repair or replacement needed after the warranty period ends shall be charged to the customer.
- The warranty does not cover the following cases:
 - (1) Using our product under any condition not covered by our defined scope of warranty.
 - (2) Failure to observe our defined precautions or instructions regarding the construction, installation, handling, maintenance, or servicing of our product.
 - (3) Any inconvenience caused by any product other than ours.
 - (4) Remodeling or otherwise modifying our product by anyone other than us.
 - (5) Using any part of our product for anything other than the intended use of the product.
 - (6) Any abnormality that occurs due to a natural disaster, accident, or other incident not stemming from something inside our product.

(2) General operating instructions



Warning

- Do not disassemble or remodel the actuator.

- Do not operate the manual override while the actuator is energized.



- Keep hands and other extremities away from moving parts under all circumstances.

(Any such practice may get your hand, arm, or other part of your body caught.)

- Using a positive-pressure gas with our plastic piping may pose a dangerous condition due to the repellent force particular to compressible fluids even when the gas is under similar pressures used for liquids. Therefore, be sure to take the necessary safety precautions such as covering the piping with protective material. For inquiries, please contact us. For conducting a leak test on newly installed piping, be sure to check for leaks under water pressure. If absolutely necessary to use a gas in testing, please consult your nearest service station beforehand.

- Before using the product, check the operating power supply and the voltage specification on the nameplate. Using an improper voltage may cause equipment damage or malfunction.

- When installing a valve, the AV gasket is basically unnecessary. But using a gasket gives more stable sealing ability in case of using a plastic flange, where easy occurrence of dent, mark or distortion can be expected.



Caution

- Do not step on or apply excessive weight on valve. (It can be damaged.)

- Do not use AV valves in a place where they may become submerged in water.

- Do not apply a great impact or vibration to the actuator. (Any such practice may result in breakdown.)

- Do not use the valve in conditions where the fluid may have crystallized.

(The valve will not operate properly.)



- Keep the valve away from excessive heat or fire. (It can be damaged, or destroyed.)

- Avoid locations with corrosive gas or otherwise bad atmospheres. Install a cover or something similar that covers the entire area.

- Always operate the valve within the pressure vs. temperature range.

(The valve can be damaged or deformed by operating beyond the allowable range.)

- Allow sufficient space for maintenance and inspection.

- Select a valve material that is compatible with the media. For chemical resistance information, refer to "CHEMICAL RESISTANCE ON ASAHI AV VALVE". (Some chemicals may damage incompatible valve materials.)

- Keep the valve out of direct sunlight, water and dust. Use cover to shield the valve.

(The valve will not operate properly.)



- Perform periodic maintenance. (Leakage may develop due to temperature changes or periods of prolonged storage, rest, or operation.)

- When installing a valve, provide an appropriate support. (Lack of such a support may cause the valve and piping to be overstrained, resulting in damage or other defect.)







- Before using the product, check the operating power supply and the voltage specification on the nameplate.

Using a wrong voltage may cause equipment damage or malfunction.

- In the case of malodor, overheating, or smoking, turn off the power supply immediately. (Continued use despite an abnormality present may result in a fire. If you detect any abnormalities, be sure to consult the dealership where you bought the product or our service station nearest your premises and ask them to perform an inspection.)

-   - For manual operation, be sure to use the handle furnished with the product by the manufacturer.
- Caution**  - When using the product in explosive atmosphere, ensure that the actuator complies with the explosion-proof specifications required for that area.
- Keep the ambient temperature of the installed location within the range -5°C and 55°C.
- If the product is not water-resistant, do not leave the actuator in soil, sand, or water.

(3) General instructions for transportation, unpacking and storage

-   - When suspending and supporting a valve, take care and do not stand under a suspended valve.
- Warning**   - This valve is not designed to handle impacts of any kind. Avoid throwing or dropping the valve.
- Caution**   - Avoid scratching the valve with any sharp object.
- Do not over-stack cardboard shipping boxes. Excessively stacked packages may collapse.
- Avoid contact with any coal tar creosote, insecticides, vermicides or paint.
(These chemicals may cause damage to the valve.)
- When transporting a valve, do not carry it by the handle.
-  - Store products in their corrugated cardboard boxes. Avoid exposing products to direct sunlight, and store them indoors (at room temperature). Also avoid storing products in areas with excessive temperatures. (Corrugated cardboard packages become weaker as they become wet with water or other liquid. Take care in storage and handling.)
- After unpacking the products, check that they are defect-free and meet the specifications.

(4) Name of parts

※Reference

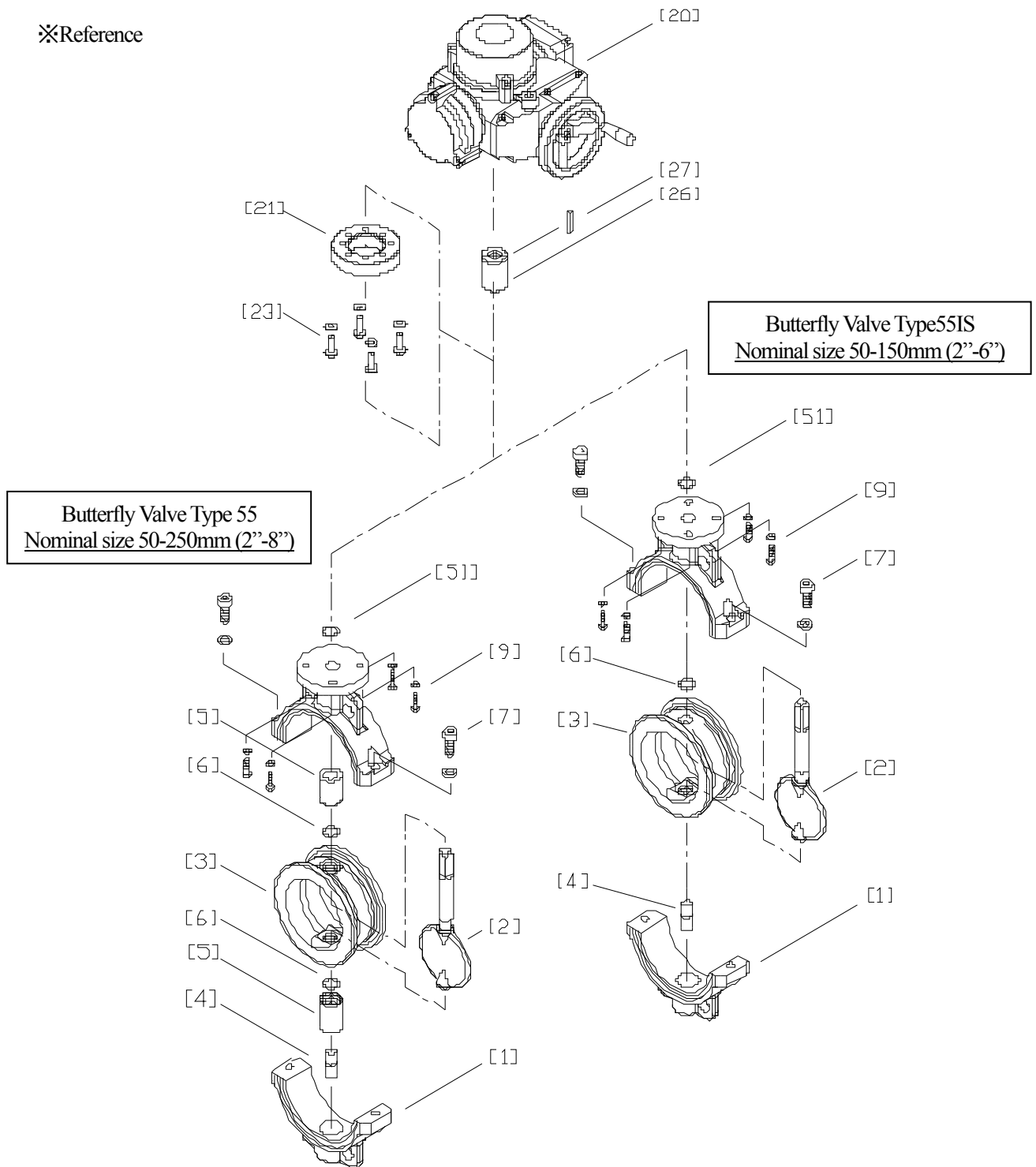

No.	DESCRIPTION	No.	DESCRIPTION	No.	DESCRIPTION
[1]	Body	[6]	O-ring (A)	[23]	Bolt (D)
[2]	Disc	[7]	Bolt (A)	[24]	Bolt (E)*
[3]	Seat	[20]	Actuator	[25]	Stem bush
[4]	Stem	[21]	Stand*	[27]	Key(A)
[5]	Bush	[22]	Joint	[51]	O-ring (B)

Stand [21] and bolt (E) [24] are used for the nominal size 125, 150mm (5", 6").

(5) Working pressure vs. temperature

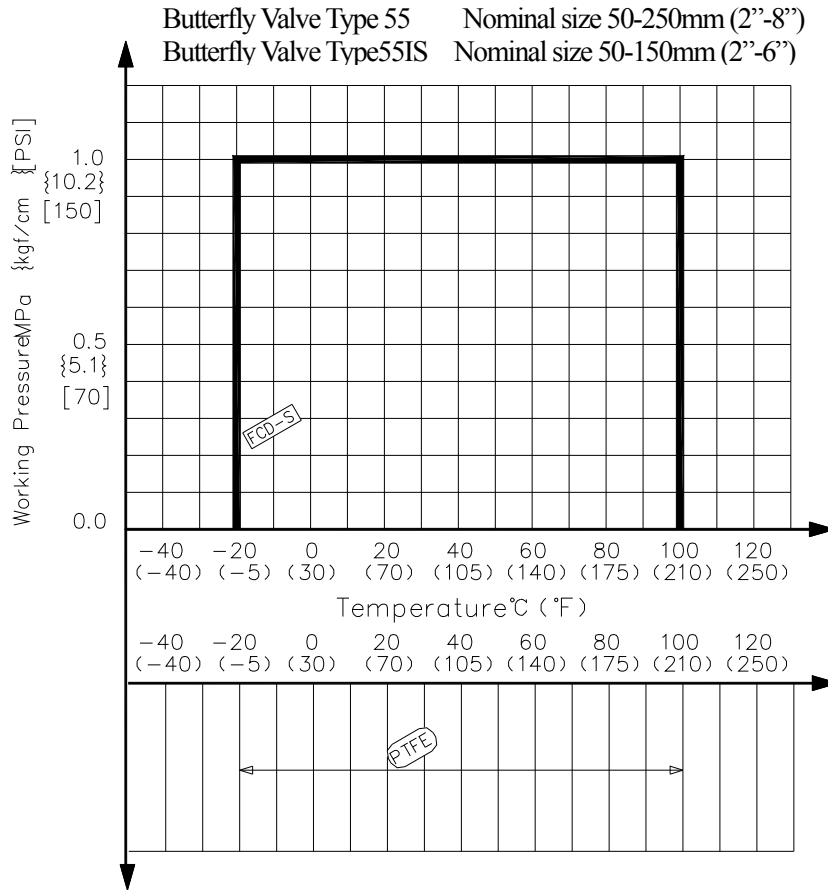

(6) Specification of actuator

List of Specifications

Adaptive Nominal Size; mm (inch)		50 (2)	80 (3)	100 (4)	125 (5)	150 (6)	200 (8)	250 (10)
Actuator Type		SRJ-010			SRJ-020		SRJ-060	
Opening and Closing Time (Sec.)	50Hz	18			36		36	
	60Hz	15			30		30	
protection structure		IP68						
Motor starting current (A) 50/60Hz	AC200V	1.27/1.19				1.89/1.77		
	AC400V	0.63/0.58				0.94/0.90		
Motor rated current (A) 50/60Hz	AC200V	0.53/0.45				0.74/0.67		
	AC400V	0.26/0.22				0.37/0.34		
Number of rotations of manual operating handle		21				26		
Watt consumption (W) 50/60Hz	AC200V	82.7/76.0				162/156		
	AC400V	84.7/78.8				163/159		
Nominal diameter of cable connector		G1						
Motor rated output (W)		40				100		
By kind of motor insulation		B kind						
Motor rated time (min.)		15						
Capacity of limit switch		AC250V 2A						
Motor polar number (P)		4						
Space heater rated output(W)		8						
Maximum impressed voltage between potentiometers (V)	135 Ω	7.3						
	200 Ω	12.6						
	500 Ω	14.0						

*In case of the actuator with electronic positioner, the current will be AC100V, 200V.

Wiring diagram

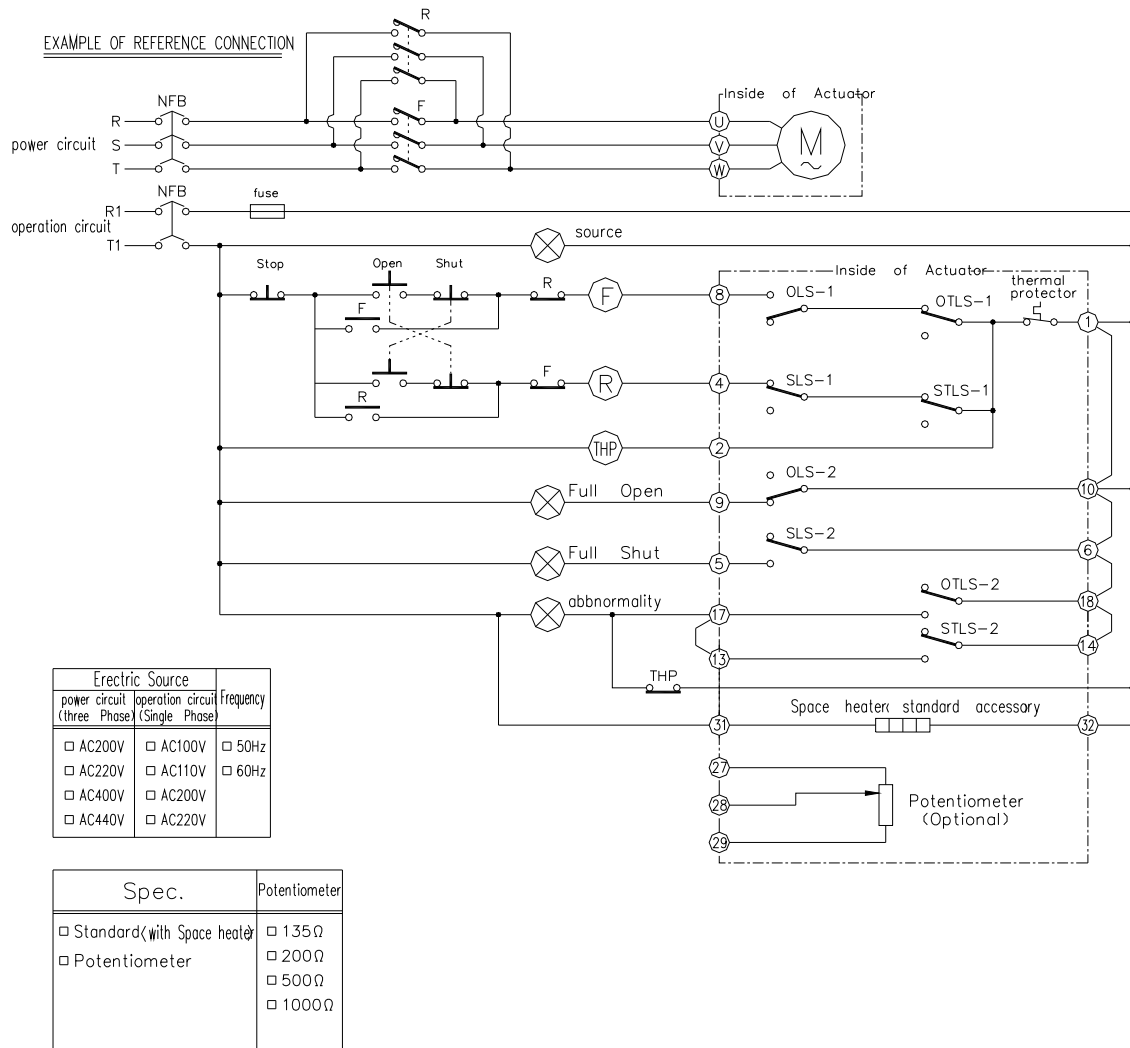

Note: The circuit diagram shows the position that the opening rotation has come to the end of travel.

Switching chart

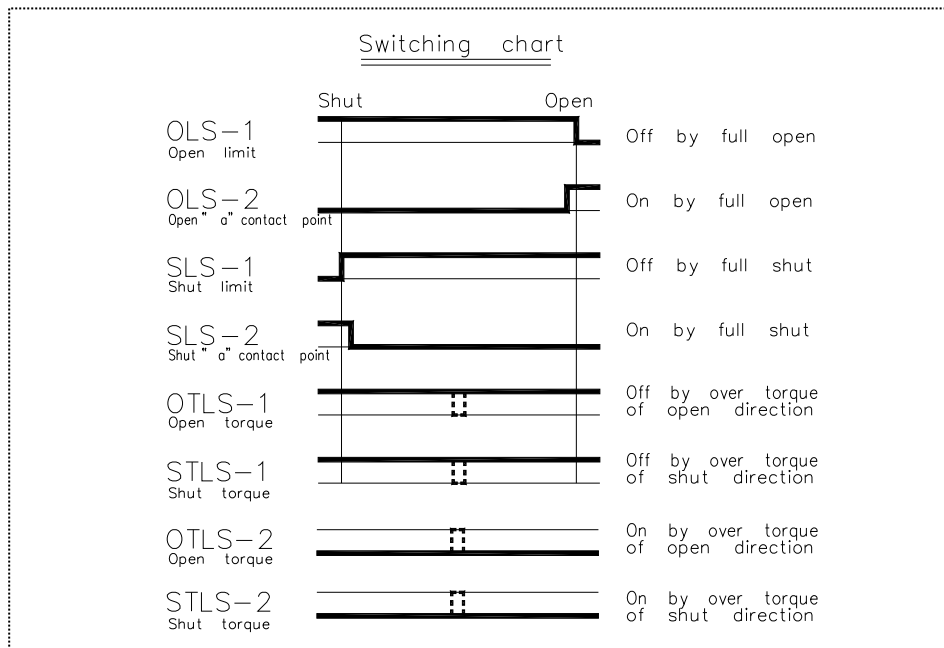

(7) Installation procedure

Warning ⚠️ - When suspending and supporting a valve, take care and do not stand under a suspended valve.

! - Be sure to conduct a safety check on all hand and power tools to be used before beginning work.

- Wear protective gloves and safety goggles as fluid remain in the valve even if the pipeline is empty. (You may be injured.)
- When installing a valve, the AV gasket is basically unnecessary. But using a gasket gives more stable sealing ability in case of using a plastic flange, where easy occurrence of dent, mark or distortion can be expected.

Caution ⚠️ - When installing a pipe support by means of a U-band or something similar, take care not to over-tighten. (Excessive force may damage the pipe.)

- When installing the piping, do not do so with the valves fully closed. (The disc may pinch into the seat, resulting in a high operating torque, thus disabling opening and closing.)
- When installing pipes and valves, ensure that they are not subjected to tension, compression, bending, impact, or other excessive stress.
- Use flat faced flanges for connection to AV Valves.
- Ensure that the mating flanges are of the same standards.
- The valve disc is in the position indicated by solid lines in figure to the right prior to shipment from the factory. If the valve is opened or closed after unpacking, it must be reset in this position before installation. Failure to do so will result in damage to the surface of the valve seat during handling and installation.
- Care must be used during piping installation to ensure that the pipes or flanges are properly aligned so that the valve disc does not contact them in any setting. Misalignment as in figure below will result in damage to the valve.

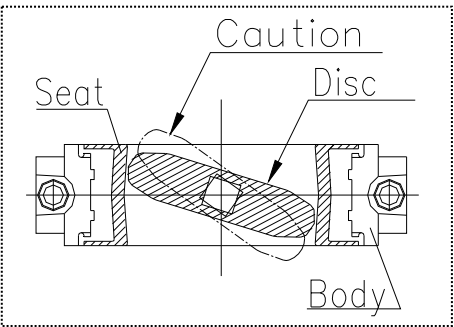
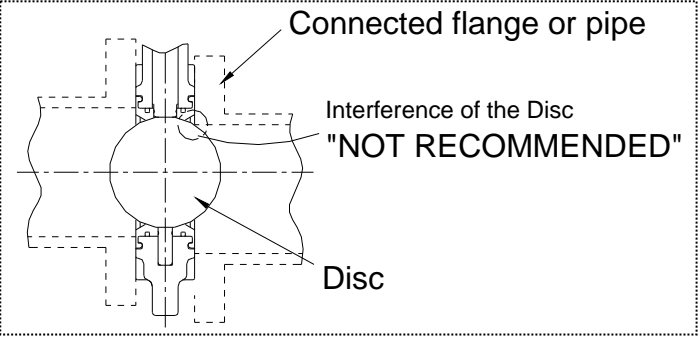
In the case of thick of the connection part (flange and pipe) is too thick shave the flange or the pipe inside order to avoid the contact of pipe and disk. If inside diameter of the connection part is larger than size D, shaving is not necessity.

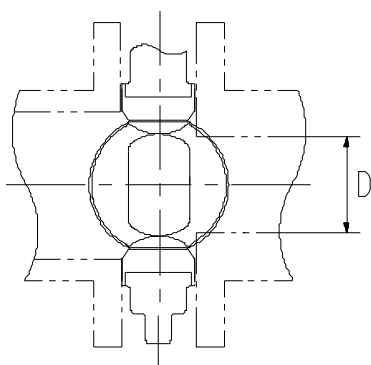

Unit: mm (inch)

Nominal size	Diameter D	
	Type55	Type55IS
50 (2")	43 (1.69")	38 (1.50")
80 (3")	68 (2.68")	70 (2.76")
100 (4")	89 (3.50")	90 (3.54")
125 (5")	116 (4.57")	117 (4.61")
150 (6")	140 (5.51")	145 (5.71")
200 (8")	177 (6.97")	- -
250 (10")	234 (9.21")	- -

Necessary items

- Torque wrench
- Bolt, Nut, Washer (For many flanges specification)
- Spanner wrench
- AV gasket (If necessary)

Procedure

- 1) Leave the disc [2] slightly opened by a Manual Handle (Refer to page 14).
 * Don't turn the disc beyond the seat.
 (Otherwise, the disc may be damaged.)
- 2) Set the valve between the coupled flange.
- 3) Insert washers and bolts from the pipe side, insert washers and nuts from the valve side, then temporarily tighten them by hand.
- 4) Using a torque wrench, tighten the bolts and nuts gradually to the specified torque in a diagonal manner (Refer to fig.1.)
 * Avoid excessive tightening. (The valve can be damaged.)

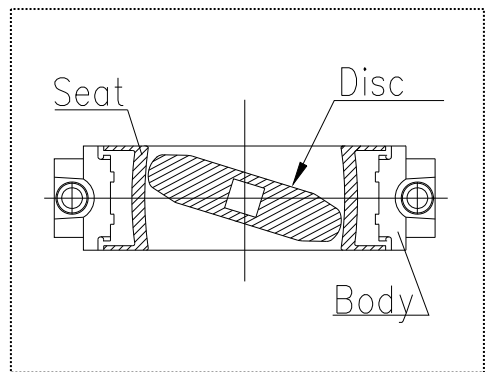
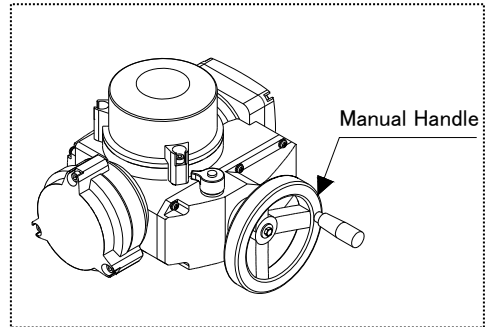

! - Tighten the bolts and nuts gradually with a torque wrench to the specified torque level in a diagonal manner.

Caution

Fig. 1

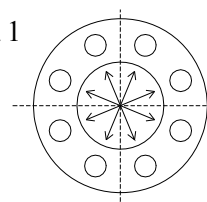



Recommended torque value

Unit: N·m {kgf·cm} [lb·inch]

Nom. Size	50mm (2", 2 1/2")	80, 100 mm (3", 4")	125, 150mm (5", 6")	200, 250mm (8", 10")
Torque value Type55	22.5 {230} {200}	30.0 {306} [266]	40.0 {408} [355]	55.0 {561} [488]

Nom. Size	50mm (2", 2 1/2")	80, 100mm (3", 4")	125, 150mm (5", 6")
Torque value Type55IS	30.0 {306} [266]	30.0 {306} [266]	40.0 {408} [355]

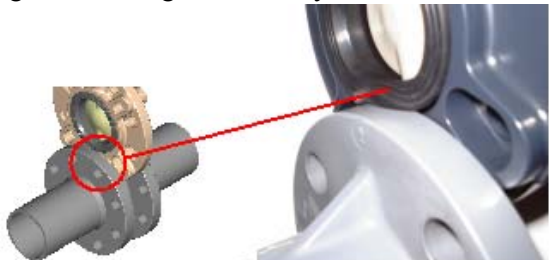

  - When you insert a valve between flanges, please insert after extending the fields of flanges fully.
 Caution (If you insert a valve by force without fully extending fields of flanges, a liner may be turned over and suffer a crack..)

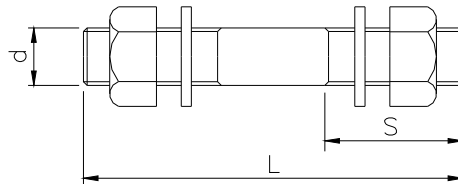

Dimension of insert bolt A

Nom.size		Bolt			Nut	Washer
		d	L	S		
50mm	2"	M16	more than 125mm (4.92")	35	M16	16
65mm	2 1/2"		more than 130mm (5.12")			
80mm	3"		more than 130mm (5.12")			
100mm	4"		more than 145mm (5.71")			
125mm	5"	M20	more than 165mm (6.50")	40	M20	20
150mm	6"		more than 175mm (6.89")			
200mm	8"		more than 190mm (7.48")			
250mm	10"	M22	more than 220mm (8.66")		M22	22





  - The parallelism and axial misalignment of the flange surface should be under the values shown in the following table to prevent damage the valve.
 Caution (A failure to observe them can cause destruction due to stress application to the pipe.)

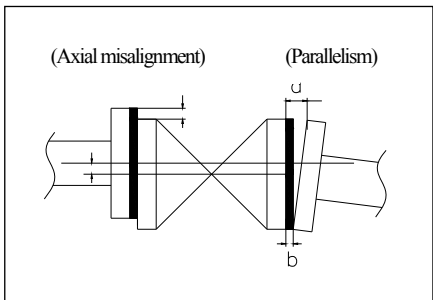

Unit : mm (inch)

Nom. Size	Axial Misalignment	Parallelism (a-b)
50-80mm (2"-3")	1.0mm (0.04")	0.8mm (0.03")
100-150mm (4"-6")	1.0mm (0.04")	1.0mm (0.04")
200-250mm (8"-10")	1.5mm (0.06")	1.0mm (0.04")



(8) Support setting procedure



 - Do not subject the valve to pump vibrations. (The valve may be damaged.)
 Caution
 - Valves must be supported. (The valve may be damaged by the weight of the actuator if it is unsupported.)

Necessary items
 Spanner wrench  U-type clamp (with bolt)  Rubber sheet

Level installation

Set the stand under the valve.

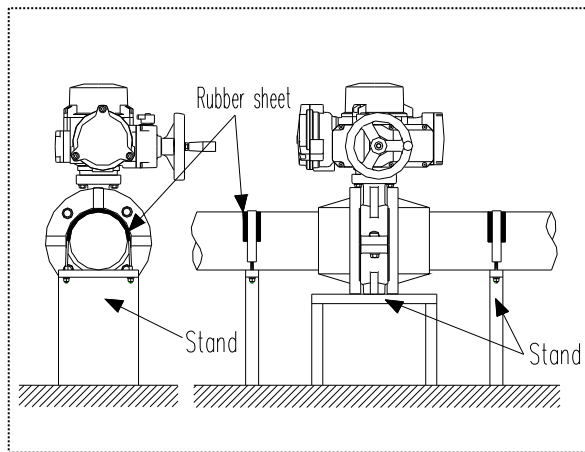
Spread the rubber sheet on the pipe and secure pipe with U-type clamp.





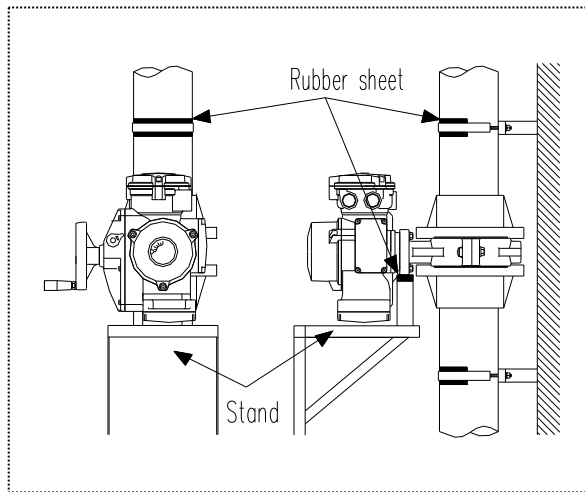

Perpendicular installation

Spread the rubber sheet under the connection part of body and actuator, and fix it with the stand.







Spread the rubber sheet on the pipe and secure pipe with U-type clamp.



(9) Electric wiring procedure

- Warning**  - Do not touch any parts on actuator circuit board or terminal block or connect or disconnect wires while the actuator is energized. (Any such practice may result in an electric shock or equipment damage.)
- Before using the product, check the operating power supply and the voltage specification on the nameplate. Using an improper voltage may cause equipment damage or malfunction.
-  - Be sure to establish a ground. (A defective ground may result in an electrical shock, fire, or other incident.)
- At the time of adjustment or inspection, ensure that your hands are free of water and oil. (Any such substance on your hands may result in an electric shock or equipment damage.)
- Caution**  - Do not exceed the rated capacity of limit switch contacts. If you wish to apply very small loads (1-100 mA, 5-30 V), consult our service station nearest to you.
- Do not use the product near high-voltage wire, inverter, or any other equipment that produces electrical noise or magnetism. (The presence of such nearby may cause malfunction or breakdown.)
 -  - Check the integrity of wiring insulation before connecting to the actuator. (Failure to observe this precaution may result in wire damage.)
 - Ensure all covers are tightly fastened prior to operation. (Insufficient fastening may allow rainwater, dust, or dirt to come in, resulting in breakdown.)
 - When connecting wires, be sure to observe the connection diagram and make the connections correctly. Moreover, after wiring, ensure that the connections are securely made before turning on the power. (Failure to take this precaution may cause malfunction or breakdown.)
 - Each cover part is sealed with an O-ring. When laying wiring or in similar cases, where the cover is removed and replaced, ensure that the O-ring is installed in the specified location and securely sealed. (Insufficient sealing may cause the actuator to be penetrated by rainwater or other foreign matter, resulting in electric shock or breakdown.)
 - If you wish to use the product outdoors or in any other location exposed to rainwater or other forms of moisture, protect the wiring conduit of the actuator against ingress of rainwater and all other wetness. (Failure to take such a precaution may cause the actuator to be penetrated by rainwater or something similar, resulting in electric shock or breakdown.)
 - In the case of malodor, overheating, or smoking, turn off the power supply immediately. (Continued use despite an abnormality present may result in a fire. If you detect any abnormalities, be sure to consult the dealership where you bought the product or our service station nearest your premises and ask them to perform an inspection.)

Necessary items

-  Spanner wrench
-  Wire stripper
-  Allen wrench
-  Crimp-style terminal
-  Terminal crimping tool
-  Screwdriver (+)
-  Connector

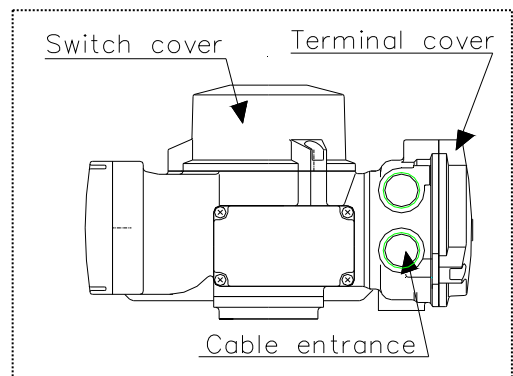

Procedure

- 1) Loosen the screws with a Allen wrench and remove the terminal cover from the actuator.
- 2) Remove the plug of cable entrance with a spanner wrench.
- 3) Install the connector in the cable entrance.





- 4) Draw a cable through the connector.
- 5) Strip cable with a wire stripper.
- 6) Install a Crimp-style terminal on the lead wire with a terminal crimping tool.
- 7) Connect terminal board with a screwdriver in accordance page 7.
 - * Tighten the screws.
 - (If not, electric leaks or shocks may occur.)
- 8) Tighten the connector.
 - * Tighten the connector.
 - (If not, electric leaks or shocks may occur.)
- 9) Tighten above screws with a screwdriver to fix and install the cover of the actuator.
- 10) Connect the earth wire to a good ground.

(10) Operating procedure

-   - Do not touch any parts on actuator circuit board or terminal block or connect or disconnect wires while the actuator is energized. (Any such practice may result in an electric shock or equipment damage.)

Warning

 - Keep hands and other extremities away from moving parts under all circumstances.
 - (Any such practice may get your hand, arm, or other part of your body caught.)
 -  - Be sure to establish a ground.
 - (A defective ground may result in an electrical shock, fire, or other incident.)
 - At the time of adjustment or inspection, ensure that your hands are free of water and oil.
 - (Any such substance on your hands may result in an electric shock or equipment damage.)
 - Do not operate the manual override while the actuator is energized.

  - Do not connect two or more motor-driven valves in series. Also, install a switch (or a relay contact) for each motor-driven valve.

Caution

 - Do not use the product near a high-voltage wire, inverter or other equipment that produces electrical noise or magnetism. (The presence of such nearby may cause malfunction or breakdown.)
 -  - Check the integrity of wiring insulation before connecting to the actuator.
 - (Failure to observe this precaution may result in wire damage.)
 - Ensure all covers are tightly fastened prior to operation.
 - (Insufficient fastening may allow rainwater, dust, or dirt to come in, resulting in breakdown.)
 - When connecting wires, be sure to observe the connection diagram and make the connections correctly.
 - Moreover, after wiring, ensure that the connections are securely made before turning on the power.
 - (Failure to take this precaution may cause malfunction or breakdown.)

Manual Operating Procedure

  - Turn off the power source.
 Caution (If the power source is turned on during the manual operation, you may be injured.)

Necessary items
 ● Spanner wrench

Procedure



- 1) Turn the Change lever in the direction of the arrow.
 (To the Position A)
- 2) Turn the manual handle while watching the valve travel indicator.

Right turn (clock wise) → Shut direction
 Left turn (counter clock wise) → Open direction

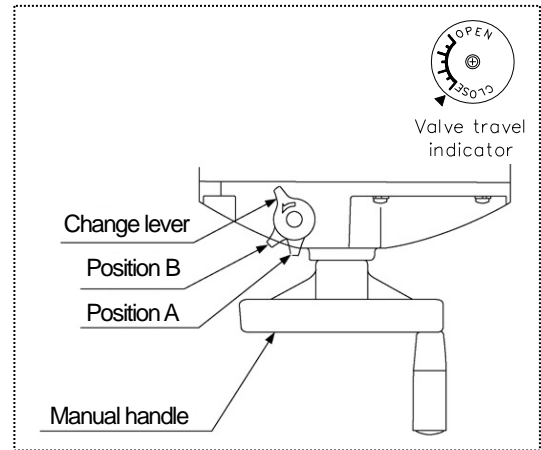
* Do not turn the handle forcibly at the right and left full operating positions.
 (If not, a trouble will develop.)



Motor-Driven Operating Procedure

  - Do not leave the terminal board cover and the limit switch cover as they are removed from the actuator.
 Warning (Coming into contact with a terminal in this state can give you an electric shock.)
 - Check to ensure that the hexagon wrench is not applied to the end of the manual operation shaft.
 (If not, the hexagon wrench will be flown by the rotation of the manual operation shaft and you may be injured by this handle.)

Procedure

- 1) Turn on the power source.
- 2) Set the external switch to “Open” or “Shut”, and check to ensure that the valve indicating direction and the operating direction accord with each other.
 (If not, check the wiring diaphragm, refer to page 7, and operate from the item 1).
- 3) Turn off the power source in the state of the full open or shut.

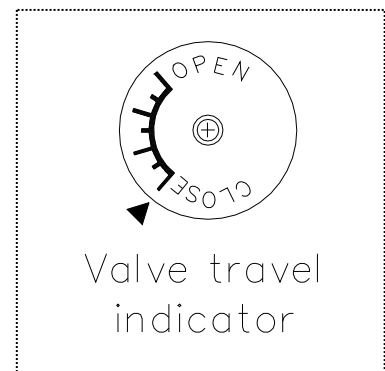

(11) Disassembly and assembly procedure

- Warning**
- Do not disassemble or remodel the actuator.
 - Do not touch any parts on actuator circuit board or terminal block or connect or disconnect wires while the actuator is energized. (Any such practice may result in an electric shock or equipment damage.)
- !**
- Be sure to conduct a safety check on all hand and power tools to be used before beginning work.
 - Wear protective gloves and safety goggles as fluid remain in the valve even if the pipeline is empty. (You may be injured.)
 - When installing a valve, the AV gasket is basically unnecessary. But using a gasket gives more stable sealing ability in case of using a plastic flange, where easy occurrence of dent, mark or distortion can be expected.
- Caution**
- Do not change or replace valve parts under line pressure.
 - Fasten the cover in each cover-equipped part. (Insufficient fastening may allow rainwater, dust, or dirt to come in, resulting in breakdown.)
 - The actuator has been adjusted at the factory. If reconfiguration or adjustment is needed, do so correctly according to the relevant operation manual. (Failure to observe this instruction may cause malfunction or breakdown.)
 - Each cover part is sealed with an O-ring. When laying wiring or in similar cases, where the cover is removed and replaced, ensure that the O-ring is installed in the specified location and securely sealed. (Insufficient sealing may cause the actuator to be penetrated by rainwater or other foreign matter, resulting in electric shock or breakdown.)

Necessary items

- Spanner wrench
- Allen wrench
- Plastic hammer
- Screwdriver(-)
- Protective gloves
- Safety goggles
- AV gasket (If necessary)

<Disassembly>

Procedure

- 1) Completely discharge fluid from pipes.
- 2) Fully close the valve by the motor-driven operation or manual operation. (Refer to page 13)
- 3) Turn off the power source.
- 4) Leave the valve slightly opened with a Manual handle.
- 5) Loosen and remove the bolt-nut.
- 6) Remove the body part from piping system.
- 7) Loosen the bolt-nut [24], and remove the actuator from the body [1].

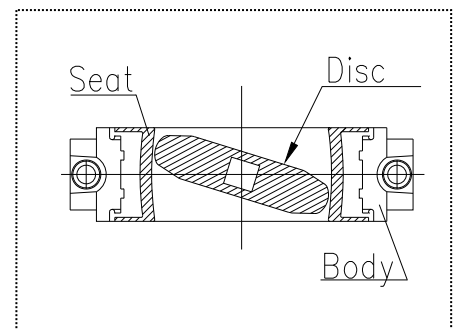
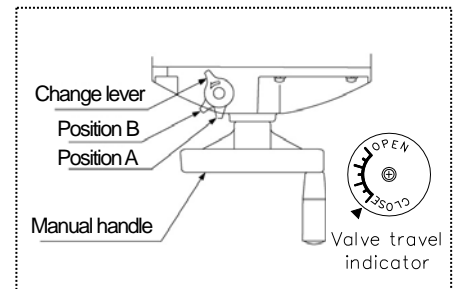

<Assembly>

Procedure

- 1) The procedure of the assembly is the reverse of its disassembly from the item 7), page 15.
- 2) Check to ensure that travel indicator shows correct position of fully open or close.
- 3) Fully open or close the valve by motor-driven operation.
(Refer to page13)
* In case that the travel indicator shows incorrect position, turn off the power source and remove the cover of the actuator with a spanner wrench, then adjust the travel indicator.

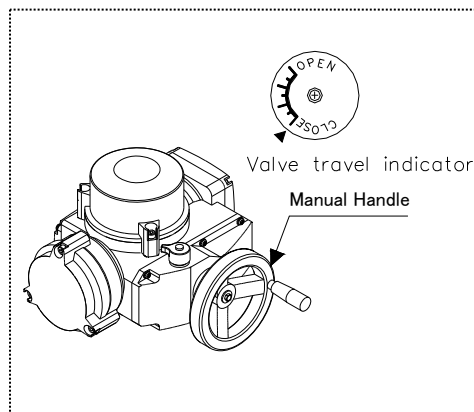

(12) Adjustment limit switch

- Shut down the power on the equipment before connecting wires. There are risks of electrical shock depending on the level of operating voltage.
- Be sure that the cover is put on during operation.
- If you plan to operate limit switches at 1mA-100mA or 5-30V, consult your nearest Asahi dealer.

- Necessary items
- Allen wrench
 - Spanner wrench

Procedure

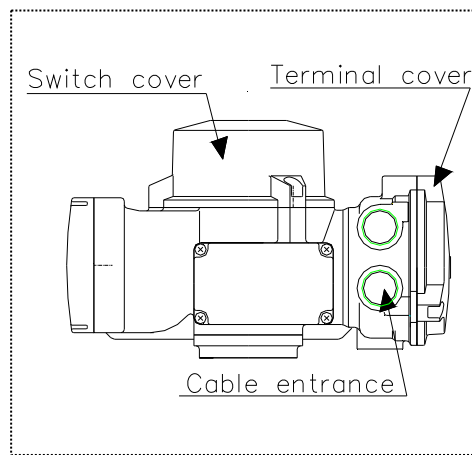

- 1) Turn off the power source.
- 2) Completely discharge fluid from pipes.
- 3) Loosen screws with a spanner, and remove the cover of the actuator.
- 4) Manually operate (refer to page 13) the valve at the valve travel (open or close) adjusted with a spanner.
- 5) Loosen the set screw (Limit switch) with an allen wrench (1.5mm).
- 6) Slowly transfer fully open or close side cam with a screwdriver (-) in the direction where this cam should be adjusted.
* Do not loose any parts. The cam can be adjusted at existing condition. (If not, the valve will not operate normally.)
- 7) Check to ensure that the limit switch works. (Refer to page 7)

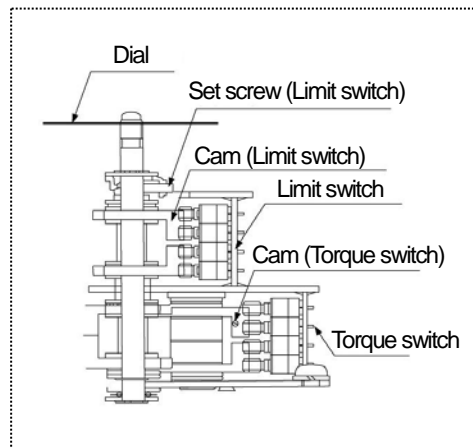

- 8) Tighten the set screw (Limit switch) with an allen wrench (1.5mm).
- 9) Check to see whether the valve travel is adjusted by manual operation. (Refer to page 13)
When the valve travel is not adjusted, repeat items 4) to 8).
- 10) Tighten the screws of the switch cover with an allen wrench (6mm).
- 11) Fully open or close the valve by motor-driven operation. (Refer to page 13)
- 12) Check to ensure that travel indicator shows correct position of fully open or close.



(13) Inspection items

  - Perform periodic maintenance. (Leakage may develop due to temperature changes or over periods of prolonged storage, rest or operation.)

Portion to be inspected	Inspection item
<p style="text-align: center;">Actuator</p>	<ul style="list-style-type: none"> 1) Existence of rust, peeling of paint, and dirt of inspection hole of valve travel indicator. 2) Tightening condition of respective threaded portions. (Loose or not) 3) The insulation resistance must be 100 MΩ or more. 4) Existence of rust and corrosion around the limit switch, and existence of internal disconnection. 5) Existence of rust and corrosion of terminal board, and existence of disconnection. 6) Existence of abnormality in opening and closing operating sounds. 7) Smooth operation of manual handle. <p>* It is unnecessary to supply oil to this actuator.</p>
<p style="text-align: center;">Valve</p>	<ul style="list-style-type: none"> 1) Existence of scratches, cracks, deformation, and discoloring. 2) Existence of leakage from the valve to the outside. 3) Existence of leakage when the valve is closed fully at right or left.

(14) Troubleshooting

Problem	Cause	Treatment
The handle is not (can't be) turned when the valve is operated manually.	The valve has already been opened fully.	Turn handle in the reverse direction. (Refer to page13)
	The valve is kept as it is electrified in the direction reverse to the handle operating direction.	Turn of the power source.
	Foreign matter is in the valve.	Remove the valve to remove foreign matter. (Refer to page 8)
	The torque of the valve is increased by the piping stress.	Remove the piping stress. (Refer to page 8)
The valve does not operate by motor-driven operations	The power source of the control panel is turned off.	Turn on the power source.
	The torque of the valve is increased by the piping stress.	Remove the piping stress. (Refer to page 8)
	The torque is increased by the influence (temperature, components, pressure) of fluid on the valve.	Check service condition. (Refer to page 5)
	The actuator is disconnected.	Check the connection again. (Refer to page7)
	Open and close are electrified simultaneously	
Fluid leaks from the valve even when the valve is shut fully.	The seat is worn.	Replace the valve with a new one.
	The disc, seat is scratched.	Replace the valve with a new one.
	Foreign matter is in the valve.	Discharge the foreign matter from the valve by opening and closing the valve several times.
	The connection bolts are too much tightened or tightened unevenly.	Adjust and retighten.
	Adjustment of limit switch is wrong.	Adjust limit switch. (Refer to page16)
	The voltage is low.	Check the voltage.
Fluid leaks from the valve.	The O-ring is scratched or worn.	Replace the valve with a new one.
	The O-ring is projected from the groove.	
	The sliding face or the fixed face of the O-ring is scratched or worn.	Replace the valve with a new one.
The actuator operate, but the valve is not opened or shut.	The stem or the joint is broken.	Replace the valve with a new one.
	The engagement between the stem and the ball is broken.	Replace the valve with a new one.
An Unusual signal comes out.	Limit switch is broken.	Replace the limit switch.
	The cam of limit switch and the cam of double limit switch approach too much.	Adjust the cam correctly.

(15) Handling of residual and waste materials



- Make sure to consult a waste treatment dealer for recommendations on the proper disposal of plastic valves.
(Poisonous gas is generated when the valve is burned improperly.)

Butterfly Valve Type 55・Type 55IS
Electric Actuated Type S

[Automatic Valve]



ASAHI AV VALVES

Distributor

<http://www.asahi-yukizai.co.jp/en/>