

SUKI

Dehumidifier WDH-735EA

User's Manual



Lion Healthcare

PO Box 566, Cottesloe, WA, 6911

Phone 1800 011 653 Email sales@salinplus.com www.salinplus.com

Contents

Structure and principle

Features	3
Specifications.....	4
How dehumidifying works.....	4
Device overview	5

Operation





Control panel	5
Operation instructions.....	6
Continuous draining	7

Maintenance

Storing the dehumidifier	8
Important safeguards	8
Caring for the dehumidifier	9
Troubleshooting	10
Warning	10
Cautions	10

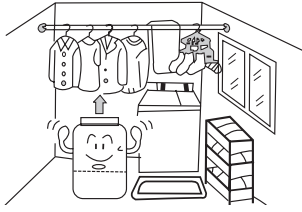
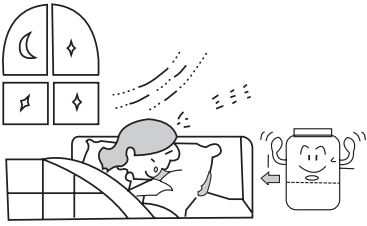
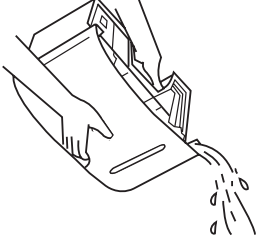
Before using your dehumidifier, please read the user's manual carefully, in order to ensure correct and safe use. After reading the manual, make sure it is stored in a safe place for future reference if necessary.

Features

<p>Powerful dehumidifying capability</p>	<p>Excellent drying laundry function</p>
<p>The dehumidifier powerfully removes excess moisture from the air creating a drier, healthier home environment.</p> 	<p>The dehumidifier dries laundry quickly. This can prevent laundry and furniture from becoming damp and musty in a rainy season.</p> 
<p>Quiet operation</p>	<p>Drainage tank with a large capacity</p>
<p>The dehumidifier is suitable for over night operation.</p> 	<p>6.2 litre capacity water tank means the dehumidifier requires emptying less often.</p> 
<p>Using refrigerant for protecting environment</p>	<p>Modern Design</p>
<p>The dehumidifier uses no CFC refrigerant therefore protecting the environment.</p> 	<p>The dehumidifier is compact with a streamlined appearance and modern design. The castors at the bottom allow easy mobility.</p> 
<p>Saving energy</p>	
<p>The power consumption is low.</p> 	

Specifications

MODEL	WDH-735EA
Power Supply	220–240V ~ 50Hz
Moisture removal	17 L/D (27°C 60%RH) 35 L/D (30°C 80%RH)
Power input	500W
Size of shell	(W x H x D) 585 x 380 x 320mm
Weight	15.5kg
Operating temperature	5°C ~ 35°C
Water tank	6.2 litres

- If the power cord on this unit is damaged it must be replaced by the manufacturer, its service agent or qualified persons in order to avoid a hazard.
- This appliance is not intended for use by children or other persons without assistance or supervision if their physical, sensory or mental capabilities prevent them from using it safely. Children should be supervised to ensure that they do not play with the appliance.

Waste electrical products should not be disposed of with household waste.

Please recycle where facilities exist. Check with your local authority or retailer for recycling advice.



How Dehumidifying Works

If you pour cold water into a cup, the air around the cup is cooled, and drops of water form on the surface of the cup. The dehumidifier takes advantage of this phenomenon to remove moisture.

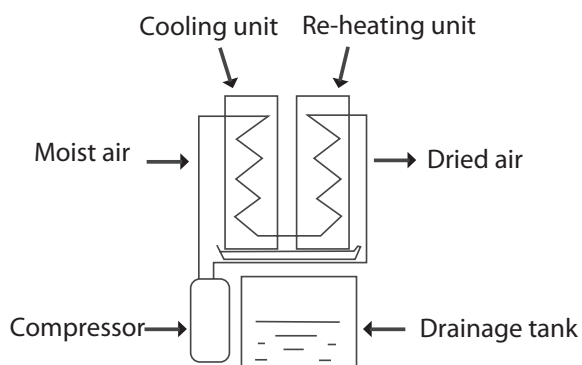

- ① It draws in room air, cools it with a cooling unit, and changes the humidity to drops of water.
 - ② The drops of water fall into a drainage tank.
 - ③ The dehumidified air is re-heated by a heating unit and discharged.
- Steps ①, ②, and ③ are repeated to remove humidity from the room.

After the air passes through the re-heating unit, its temperature will rise a little, so that the temperature of the room will rise by 2 to 4°C. This is normal operation.

Device Overview

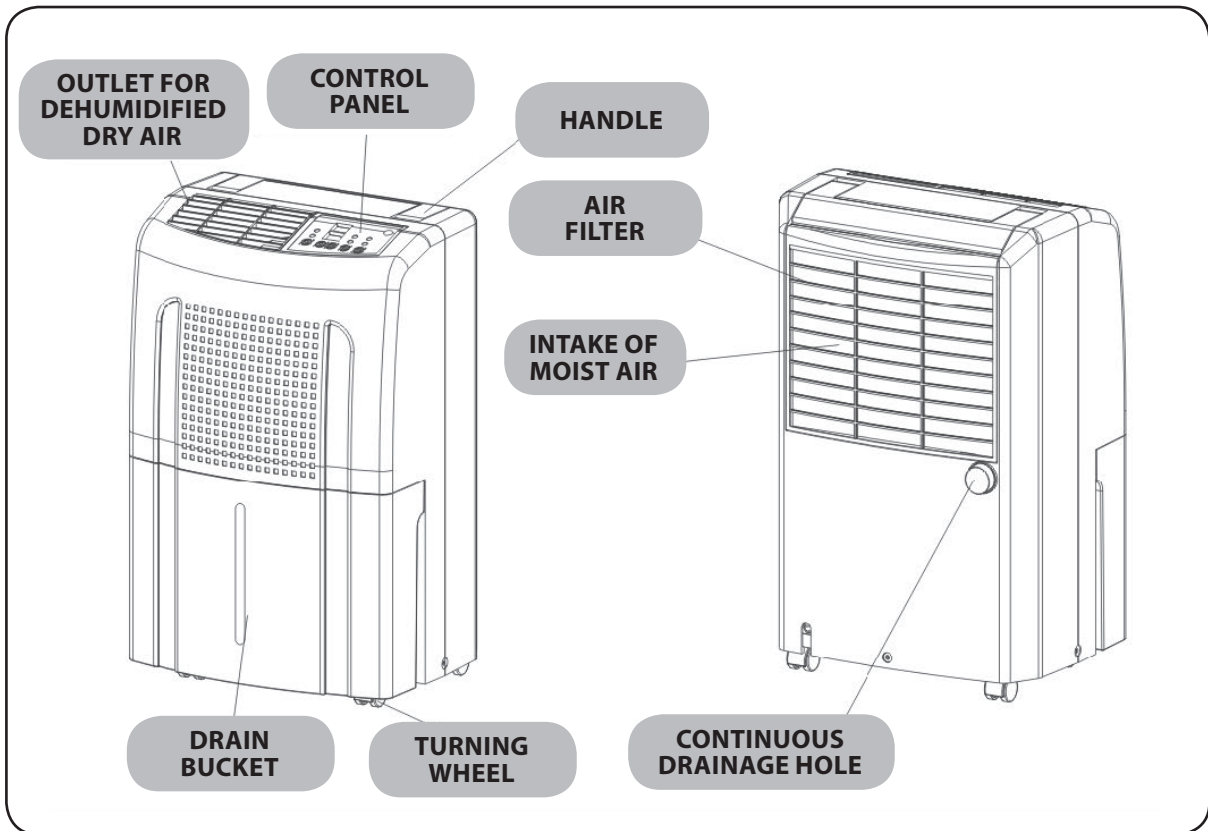

Control panel

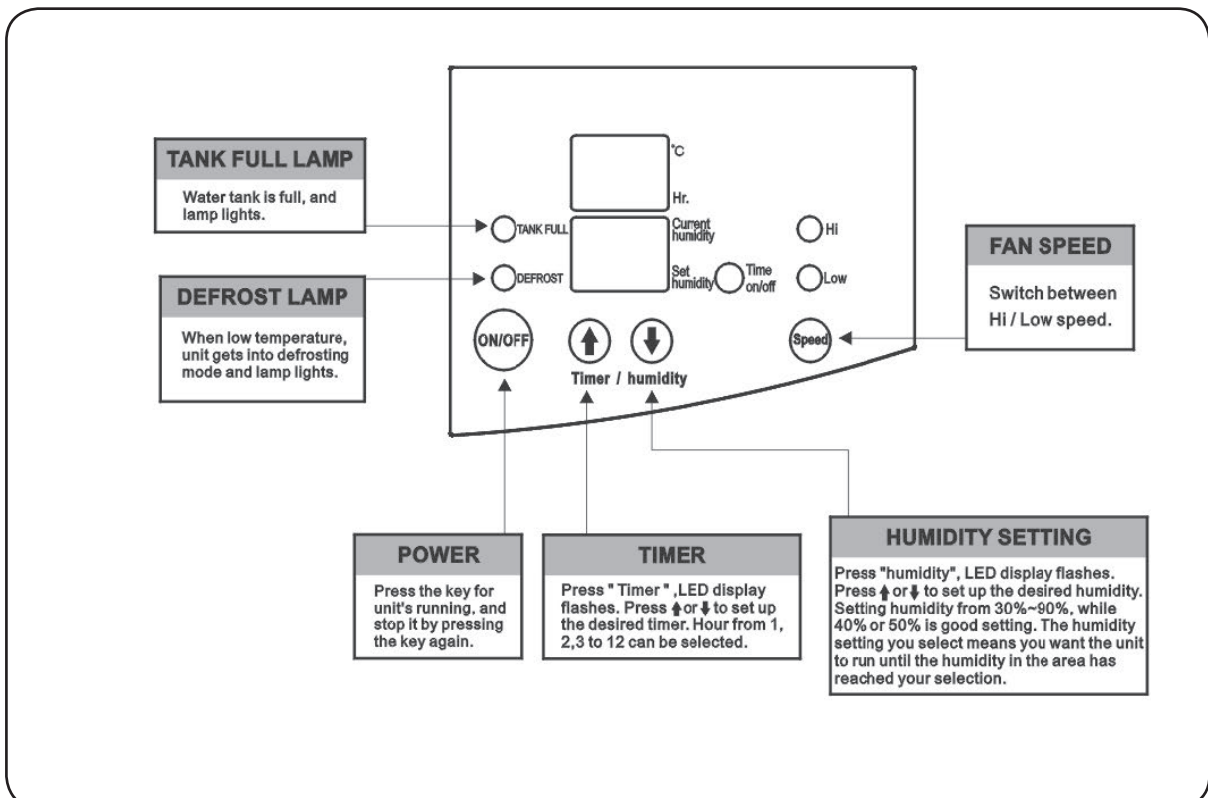

Operation Instructions

START OPERATION

1. Make sure the plug is firmly plugged into the wall socket.
2. Make sure the device water tank is placed in its correct position. (After powering on the device for the first time, if the full tank light lights up, just pull out the water tank then push it back to the proper position).

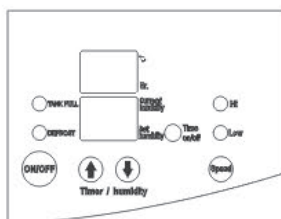
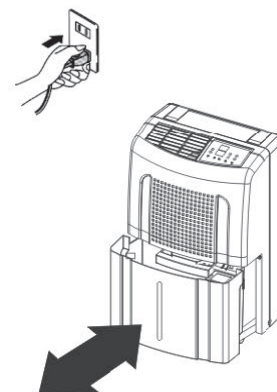

WHEN FULL TANK LIGHT IS ON

When the water tank is full, the indication light will light up, the device will stop operating. Remove the water in the tank, then place the water tank back in its proper position, the device will start operating again.



Remove the water in the water tank with two hands

TIMER OPERATION

The timer can be used to turn the device ON or OFF when you are away from the premises. On a 12Hr cycle. To turn the device on. With the cable connected into the socket (DO NOT START THE DEVICE) press timer button to the amount of hrs when you want the device to start (shown on the screen) it is now set to come on automatically. To set time to turn off. With the device running press timer button to the amount of hours when you want the device to automatically stop.

DEFROST

When operating in low temperatures (less than 12°C) the surface of the evaporator will accumulate frost and effect the efficiency of the dehumidifier. When this happens the device will go into periodic defrost mode automatically. This is quite normal. Defrost light will come on. The device will operate in temperatures down to 5°C in the area it is being used. Defrost times may vary. If the dehumidifier freezes up turn the device off and let ice melt then turn the device back on. If the device freezes up again it may be that the temperature is lower than 5°C, if it is, then you should not run the device until the temperature rises. If the device continues to freeze up it may need looking at, return it to the place of purchase to be sent back for service.

Continuous Drainage

CONTINUOUS DRAINAGE OPTION

1. To save having to periodically drain the water tank of condensate, this unit can be configured for continuous drainage. You can use the supplied drain hose to connect to the drain port.

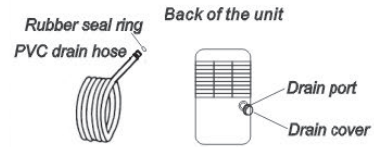

2. Unscrew and remove the drain cover at the rear of the unit. Remove the soft rubber pad. Put the rubber pad into the water tank for safe keeping.

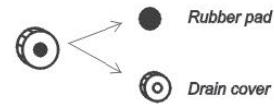

3. Insert the drain hose through the hole of the drain cover.

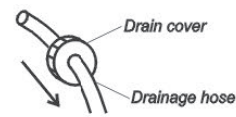

4. Ensure the supplied rubber sealing ring is properly seated in the end of the hose.

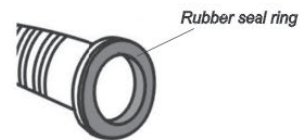

5. Connect the drain hose to the drain port. Tighten the drain cover in clockwise direction onto the rear of the unit.

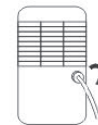

Always keep the hose and seal in a safe place as there will be a charge if you need to replace them.

THE PROPER WAY TO PLACE THE WATER DRAINAGE PVC HOSE

When using continuous drainage, the PVC hose must be placed below the drainage hole. Avoid uneven ground and kinking drainage hose.

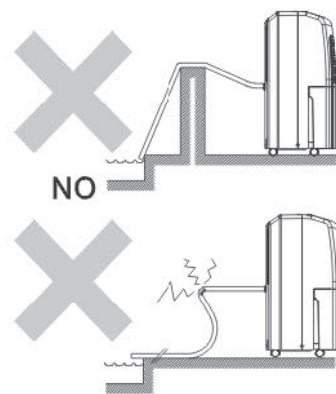
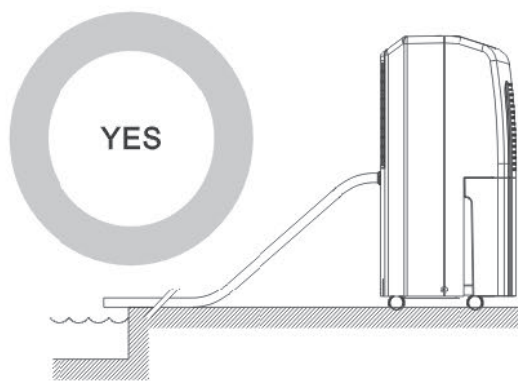

Storing the Dehumidifier

When the device is not to be used for a long period of time

1. Fold up the power supply cord.
2. Discard any water left in the drainage tank and wipe away any remaining drops with a cloth.
3. Clean the air filter.
4. Store the device. Package the device to keep it free of dust, and keep it upright and store it in a cool, dry place.

Important Safeguards

Please note the following safety precautions when using the unit:

1. When the dehumidifier is used in the laundry, ensure there is adequate clearance between any clothes and the device to prevent water dripping on the unit.
2. Before cleaning the device or when it is not in use for a long period of time, unplug the power cord.
3. Do not use the dehumidifier in the immediate surroundings of a bath, shower, or swimming pool.
4. Do not place the device close to a heater, or any appliance which will have a high temperature.
5. Do not place any objects into the air inlet or outlet.
6. Do not sit or stand on the unit.
7. Discard water that has collected in the tank regularly.
8. Do not place the dehumidifier in an enclosed area, ie. closets, which will prevent air circulation.
9. Do not use the dehumidifier for any purpose other than for which it was originally intended.
10. Install the external drain piping on a downhill gradient to ensure that condensed water can be drained continuously.
11. If the supply cord is damaged, it must be replaced by the manufacturer or its service agent or a similarly qualified person in order to avoid hazard.
12. The device is not intended for use by young children without supervision.

Caring for your Dehumidifier

Before cleaning your dehumidifier, first ensure that the device is disconnected from power supply.

1. Outer case:
Wipe the shell with a soft, slightly damp cloth. Do not immerse in any liquid. Dry with a dry cloth. Do not use harsh abrasives or solvents.

2. Air filter cleaning:
For best results, clean your air filter regularly, as it will become clogged with dust over time.

- Pull out the filter gently.
- To clean the air filter, run a vacuum cleaner lightly over the surface of the air filter to remove dirt. If the air filter is very dirty, wash it with warm water and a neutral cleaning solvent and dry it thoroughly.

3. Insert to its original position.

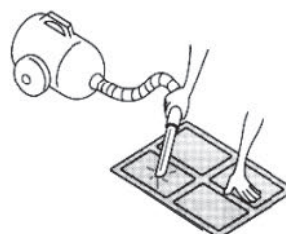
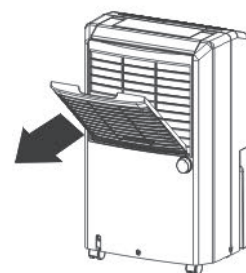

Troubleshooting

In case your dehumidifier shows any abnormality, please check the items mentioned below first:

Problem	Possible cause	Solution
Both fan and compressor not working.	No power to unit.	Check power to socket. Check power switched on.
Compressor or fan not working.	Motor failure. Faulty electronics.	Return for service.
Not collecting water.	Air intake filter blocked. Refrigerant is low. Temperature and humidity are too low.	Clean filter. Return for service. Normal function.
Noisy unit.	Floor uneven.	Place on a level surface.
Condenser frozen.	Filter is dirty. Temperature is too low.	Clean filter. Switch off and wait for temperature to rise.
Leaks.	Bucket not installed properly. Micro switch failure. Unit has frozen.	Fit properly. Return for service. Unplug and allow ice to melt.

Warning

Do not fold or knot the power cord as shown below!



Make sure the plug is inserted firmly and properly into the outlet!

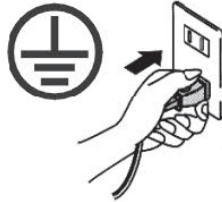

Do not insert multiple plugs into the electrical socket as shown below!

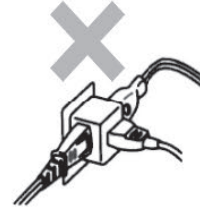

Make sure the plug is clean!



After turning off the device, unplug the power cord!

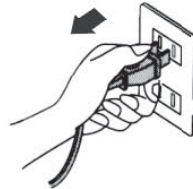

Do not plug in the power cord if hands are wet!



Cautions

Do not place anything on top of the control panel!



Do not cover the device's air vents!

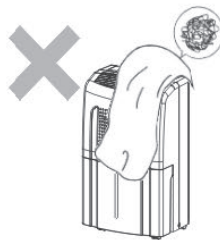

Do not allow children to climb on or play with the device!

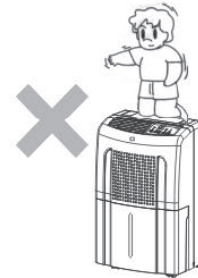

Do not wet the device or control panel!

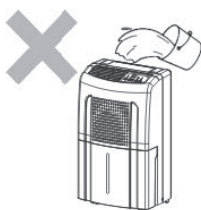

Keep flammable materials away from the device!



Contact a professional for service repair!

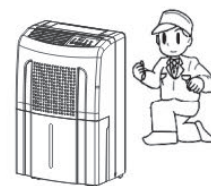

Cautions

Do not pull the power cord as shown.

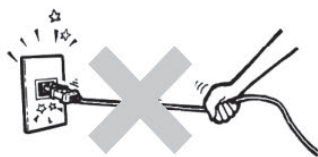

Do not spray any aerosols near the device.

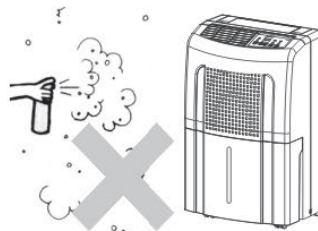

Ensure the device is placed on a flat surface.

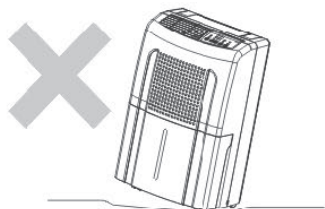

Always keep the device at least 20 cm away from the wall to allow heat to dissipate properly. Hang clothing at least 50 cm above the device.

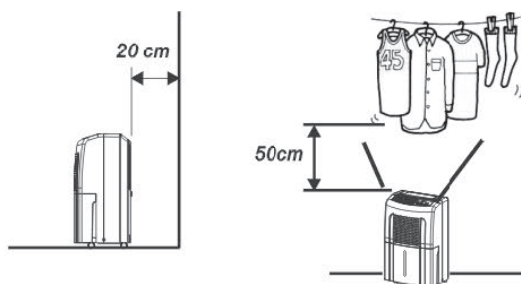

Do not insert anything into the device.



For best results close all windows and doors.



Keep the device away from all sources of heat.

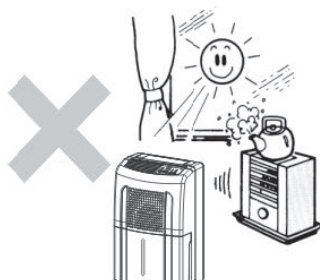

When moving or storing the device, do not place it sideways or upside down.

