

Operation manual

AIRLESS-DEVICES

Model:

- PROFIT
- PHOENIX
- PROFESSIONAL
- HERKULES
- SUPER

Type:

- Airless
- Hot Job

Installation size:

Serial-No.:



Contents

1 Foreword	7
2 Safety	8
2.1 Explanation of symbols.....	8
2.2 Safety notes.....	10
2.2.1 Operating pressure	10
2.2.2 Risks caused by the spray jet	10
2.2.3 Hazard from electrostatic charging.....	11
2.2.4 Hazards from hot/cold surfaces	11
2.2.5 Explosion protection	12
2.2.6 Health risks	12
2.3 Information signs on the unit	13
2.4 Safety features	13
2.4.1 Safety valve	14
2.4.2 Compressed air shut-off valve	15
2.4.3 Ground cable	15
2.5 Operating and maintenance personnel	15
2.5.1 Unit owner's duties	15
2.5.2 Personnel qualification.....	16
2.5.3 Authorized operating personnel.....	16
2.5.4 Personal Protective Equipment (PPE).....	16
2.6 Notes on warranty	17
2.6.1 Conversions and alterations	17
2.6.2 Spare parts	17
2.6.3 Accessories.....	17
2.7 Emergency procedures	18
2.7.1 Stop the unit and release the pressure.....	18
2.7.2 Leakages	18
2.7.3 Injuries	18
3 Unit Description	19
3.1 Intended use.....	19
3.1.1 PROFIT series	20
3.1.2 PHOENIX series	20
3.1.3 SUPER series.....	20
3.1.4 PROFESSIONAL series	21
3.1.5 HERKULES series.....	21
3.2 Unit design.....	21
3.2.1 PROFIT series	22
3.2.2 PHOENIX series	23
3.2.3 SUPER series.....	24

3.2.4 PROFESSIONAL series	25
3.2.5 HERKULES series	26
3.3 Compressed air regulator	27
3.4 Air maintenance unit	28
3.5 Optional accessories and expansion parts	29
3.5.1 Spraying accessory kits	29
3.5.2 Material flow heater	29
3.5.3 Agitator	30
3.5.4 De-icing	30
3.5.5 Material return flow control	30
4 Transport, installation and assembly	32
4.1 Transportation	32
4.2 Installation location	32
4.3 Assembly	33
4.3.1 Mounting the wall bracket (optional)	34
4.3.2 Assembling spray hose and spray gun	34
4.3.3 Grounding the unit	35
4.3.4 Connecting the compressed air supply	35
5 Operation	37
5.1 Commissioning the unit	37
5.2 Spraying	38
5.2.1 Adjusting the spraying pressure	38
5.2.2 Advice for achieving good coating results	39
5.3 Hot spraying / operation with material heater	39
5.3.1 Adjusting the operating pressure	41
5.3.2 Operation with material heater with circulation	41
5.3.3 Operation with material heater without circulation	42
5.4 Flushing	42
5.4.1 Cleaning the material return flow control (optional)	43
5.5 Material change	43
5.6 Releasing pressure	44
5.7 Work breaks	44
5.8 Decommissioning	44
5.9 Disposal	45
6 Maintenance	46
6.1 Regular inspections	46
6.2 Maintenance plan	47

6.3	Maintenance unit	47
6.3.1	Checking the lubricant level in the fog oiler	48
6.3.2	Checking and adjusting the fog oiler.....	48
6.3.3	Checking and cleaning the water separator	48
6.4	High pressure pump	49
6.4.1	Topping up release agent	49
6.4.2	Checking the release agent for material residue	49
6.5	High pressure filter	50
6.5.1	Removing the filter element.....	50
6.5.2	Cleaning the filter element.....	51
6.5.3	Filter elements for high pressure filters.....	51
6.6	Recommended operating materials.....	52
6.7	Special tools	52
7	Rectification of faults	53
8	Technical data	55
8.1	PROFIT series.....	55
8.2	PHOENIX series.....	55
8.3	SUPER series.....	56
8.4	PROFESSIONAL series	56
8.5	HERKULES series.....	57
8.6	Unit card	57
8.7	Type plate	57

1 Foreword

Dear Customer

We are delighted that you have decided to buy one of our devices.

This operation manual is intended for the operating and maintenance personnel. It contains all the information required for working with this unit.



The owner of the unit has to ensure that operators and maintenance personnel always have an operation manual at their disposal in a language that they understand.

Safe and reliable operation of the unit requires further information in addition to this operation manual. You should have read and understood the guidelines and accident prevention regulations that apply in your country.

In Germany, these are as follows:

- ZH 1/406 “Richtlinien für Flüssigkeitsstrahler” (Guidelines for Liquid Jets), published by the German “Hauptverband der Gewerblichen Berufsgenossenschaften”;
- BGR 500, chapter 2.29 “Application of Coating Materials”;
- BGR 500, chapter 2.36 “Working with Fluid Spraying Equipment” published by the employers liability insurance association for the gas, remote heating and water management sectors.

We strongly recommend adding all relevant guidelines and accident prevention instructions to this operation manual.

Moreover the manufacturer’s instructions and guidelines for coating or feeder materials must be respected at all times.

However, if you have any questions, please do not hesitate to contact us.

Best wishes for good results with your unit from

WIWA Wilhelm Wagner GmbH & Co. KG

Copyright

© 2014 WIWA

This operation manual remains the copyright of **WIWA** Wilhelm Wagner GmbH & Co. KG.

Gewerbestr. 1-3 • 35633 Lahnu • Germany

Tel.: +49 6441 609-0 • Fax.: +49 6441 609-50 • Email: info@wiwa.de • Internet: www.wiwa.de

This operation manual is solely intended for personnel involved in preparation, operation and servicing.

It is prohibited to pass on this operation manual for reproduction, utilisation or communication of its contents, unless this has been explicitly permitted. Non-compliance may result in claims for damage compensation. All rights reserved in the event of registration of the patented design, industrial design or registered design.

2 Safety

This unit has been designed and manufactured taking into consideration all safety-related aspects. It complies with the current standard of technology and relevant accident prevention regulations. The device left the factory in perfect condition and guarantees a high level of technical reliability and safety. Nevertheless, there are certain risks that can arise from incorrect operation or misuse:

- to life and limb of the operator or third parties,
- to the unit and other material assets of the owner,
- to the efficient working capacity of the unit.

You must refrain from any working methods that could affect the safety of operating personnel and equipment. Everyone involved in set-up, commissioning, operation, maintenance, repair and servicing of the unit must have read and understood the operation manual beforehand, especially the chapter entitled "Safety".

Your safety is at stake!

We recommend that the device operator obtains written confirmation that this has been done.

2.1 Explanation of symbols

Safety notes warn you of potential risks of accidents and tell you the measures that are required to prevent accidents.

In **WIWA** operation manuals, safety notes are specially highlighted and marked as follows:



DANGER

Indicates danger of accidents; if you ignore the safety notes, there is a high risk of severe injury including death!



WARNING

Indicates danger of accidents; if you ignore the safety notes, there is a high risk of severe injury including death!



CAUTION

Indicates danger of accidents; if you ignore the safety notes, severe injury can result!



Indicates important information on correct use of the unit. Ignoring it can result in damage to the unit or in its vicinity.

In the safety notes about the risk of accidents, different pictograms are shown after each hazard source – examples:



General accident risk



Risk of explosion from explosive atmosphere



Risk of explosion from explosive substances



Danger of injury due to electric voltage or electrostatic charging



Risk of crushing by moving unit parts



Risk of burning due to hot surfaces

Mandatory safety instructions primarily concern personal protective equipment to be worn. They are particularly highlighted and marked as follows:



Wear protective clothing

Indicates the requirement to wear the prescribed protective clothing to protect against skin injuries caused by spraying material or gases.



Use eye protection

Indicates the requirement to wear protective goggles to protect against eye injuries caused by gases, fumes or dust.



Wear ear defenders

Indicates the requirement to wear ear defenders to prevent your hearing from being damaged by noise.



Use a respiratory protection mask

Indicates the requirement to use a respiratory protection mask to prevent your respiratory tract from being damaged by gases, fumes or dusts.



Wear protective gloves

Highlights the order to wear protective gloves with lower arm protection to protect against burn injuries caused by heated materials.



Wear protective footwear

Highlights the order to wear protective footwear to prevent injuries to the feet due to objects that may fall, drop or roll around or to hot or caustic liquids.



Indicates references to guidelines, work instructions and operation manuals that contain important information which you must observe at all times.

2.2 Safety notes

Please remember that the devices work at high pressure and may cause life-threatening injuries if used inappropriately!



Always observe and follow all instructions in this operation manual and in the separate operating manuals of individual unit parts and/or the optionally available accessory devices.



The accident prevention instructions “Application of Coating Materials” (BGR 500, chap. 2.29) and the guidelines for liquid jets ZH1/406 of the employer’s liability insurance association must strictly be complied with.

2.2.1 Operating pressure



WARNING

Components that do not comply with the maximum permissible operating pressure can burst and cause serious injury.

- The specified maximum operating pressures must generally be complied with for all components. In case of varying operating pressures, the lowest value is always the one to be taken as the maximum operating pressure for the entire unit.
- Material hoses and hose assemblies must comply with the maximum working pressure, including the required safety factor.
- Material hoses must be leak tight and free of kinks, signs of abrasion or bulges.
- Hose connections must be tight.

2.2.2 Risks caused by the spray jet



WARNING

The material is discharged from the spray gun under very high pressure. Due to its cutting effect the spray jet can cause severe injuries by penetrating the skin or entering into the eyes.

- Never point the spray gun at yourself, other persons or animals.
- Do not hold your fingers or hands in front of the spray gun!
- Do not reach into the spray jet with your hands!



WARNING

Unintentional material release from the spray gun may cause personal injury or damage to property.

- Always secure the spray gun during every work break!
- Always check that the safety mechanism on the spray gun works before each use!

2.2.3 Hazard from electrostatic charging



WARNING

The high flow velocities associated with the Airless spraying method may cause electrostatic charging. Static discharges can cause fire and explosion.

- Ensure that the unit has been properly grounded outside of explosive atmosphere areas!
- Also ground the object to be coated.
- Always use open containers!
- Never spray solvents or materials containing solvent into cone-top cans or drums with a bung-hole!
- Place the containers on a grounded surface.
- Always use electrically conductive containers.
- Avoid contact between spray gun and container wall.
- Use only electrically conductive material hoses.
All original material hoses from **WIWA** are conductive and perfectly adapted to our equipment.



WARNING

If the unit is contaminated by material during operation, the increased coating thickness can lead to electrostatic charging. Static discharges can cause fire and explosion.

- Clean the unit immediately to remove any contamination.
- Carry out cleaning work outside areas with explosive atmospheres.

2.2.4 Hazards from hot/cold surfaces



CAUTION

The use of material heaters can cause the surfaces of the unit to become hot. Risk of burns.

- Always wear protective gloves with lower arm protection (gauntlet) when working with heated materials!



CAUTION

The air motor becomes very cold during operation. There is a high risk of local frostbite.

- The air motor should warm up to a temperature above 10 °C before starting any work on the unit.
- Always wear suitable protective gloves!

2.2.5 Explosion protection



WARNING

Units that are designed without explosion protection must not be used in workshops that are subject to the explosion protection ordinance.

Whether your unit has explosion protection is indicated by the  symbol on the type plate and/or on the enclosed ATEX declaration of conformity.

Explosion-protected machines meet the explosion protection requirements of Directive 94/9/EC for the explosion group, unit category and temperature class specified on the type plate or in the declaration of conformity.

The operator is responsible for determining the zone allocation according to the Directive of EC 94/9/EC, Appendix II, no. 2.1-2.3 when observing the measures of the responsible inspecting authority. The operator is responsible for checking and ensuring that all technical data and markings according to ATEX correspond with the necessary requirements.

Please note that several components have their own type plate with separate marking according to ATEX. In this case the lowest explosion protection of all attached markings applies to the entire unit. Applications where the malfunction of the unit can lead to danger to personnel must be provided with respective safety measures by the operator.

However, explosion protection has to be checked if agitators, heaters or other electrically operated accessories are additionally mounted. Plugs for heaters, agitators, etc. that do not have explosion protection, may only be plugged in outside of areas that fall under the explosion protection ordinance, even if the accessory equipment as such is explosion protected.



WARNING

Heating up solvents can cause an explosion. This may result in serious injury to persons and damage to property.

- Pay attention to the flashpoint and the ignition temperature of the solvent.
- Switch off the material flow heater if you need to perform the following work: Cleaning, pressure testing, decommissioning, maintenance and repair.

2.2.6 Health risks



CAUTION

Depending on the materials being applied, solvent vapours may be generated which could cause damage to health and objects.

- Always ensure sufficient aeration and ventilation at the workplace.
- Always observe the processing instructions issued by the material manufacturers.



Follow the safety notes and dosing information of the manufacturer and the generally applicable regulations when handling paints, cleaning agents, oils, greases and other chemical substances.



When cleaning your skin, use only appropriate skin protection, skin cleaning and skin care products.

In closed or pressurized systems dangerous chemical reactions may occur if parts made of aluminium or galvanized parts come into contact with 1.1.1 - trichloroethane, methylene chloride or other solvents containing halogenated hydrocarbons (CFCs). If you want to process materials containing the afore mentioned substances, we recommend to consult the material manufacturer to clarify the usability of such substances.

For these materials, we have available a range of rust- and acid-proof units.

2.3 Information signs on the unit

Information signs attached to the unit, such as safety information (Fig. 1), refer to possible danger areas and must be strictly observed.

They must not be removed from the unit.

Damaged and illegible information signs must be replaced immediately.

Apart from this you should also read and follow the safety notes in the operation manual.



Fig. 1: Safety Information

2.4 Safety features



WARNING

If one of the safety features is missing or not fully functional, the operating safety of the unit cannot be guaranteed!

- If you discover any faults in the safety features or other deficiencies on the unit, stop operation of the unit immediately.
- Only resume operation of the unit after the fault has been completely eliminated.

Safety features must be checked on the unit:

- before initial commissioning,
- always before starting work,
- after set-up work,
- after all cleaning, servicing and repair work.

The unit is equipped with the following safety features:

- Safety valve
- Compressed air shut-off valve
- Ground cable



Please observe the operation manual for use for the optional accessories when testing other safety features.

Checklist

on the depressurized unit:

- Lead seal on the safety valve still intact?
- Safety valve free of external damage?
- Ground cable free of damage?
- Are the ground cable connections on the unit and the conductor in good condition? (see Chapter 2.4.3 Ground cable on page 15)
- Operability of compressed air shut-off valve correct?

on the pressurized unit:

- Function of safety valve correct? (see Chapter 2.4.1 Safety valve on page 14)

2.4.1 Safety valve

There is one safety valve on the unit:

- on the air motor

The safety valve prevents the maximum permissible air inlet pressure from being exceeded. The safety valve will open and vent off air when the air inlet pressure exceeds the set limiting value.

How to check the function of the safety valve:

Briefly increase the air inlet pressure by about 10 % above the maximum permitted pressure as stated on the type plate. – The safety valve has to discharge.

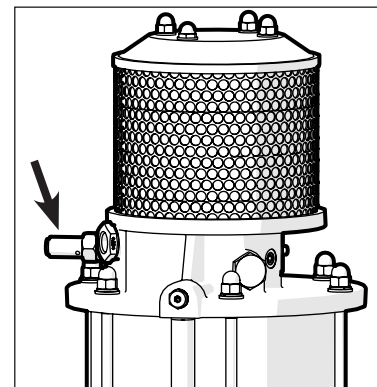

Fig. 2: Safety valve



WARNING

If the maximum permissible air inlet pressure is exceeded, components may burst. This may result in damage to persons and property.

- Never allow the unit to run without a safety valve or with a defective one!
- If the safety valve needs to be replaced, you can find the corresponding order number on the unit card.
- With new safety valves, ensure that they have been set to the maximum permissible air inlet pressure of the unit (see type plate/unit card) and sealed with a lead seal.

2.4.2 Compressed air shut-off valve

The compressed air shut-off valve enables immediate shutting down of the unit.

Principle of function:

- Open ⇒ Set ball valve in the direction of flow

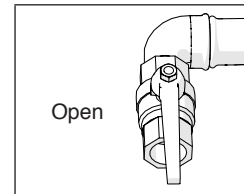

- Close ⇒ Set ball valve across the direction of flow

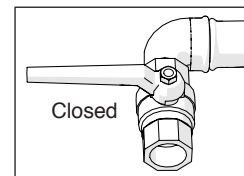

After shutting off the air, the unit is still pressurized. This means that before carrying out maintenance and repair work, you must always carry out a complete pressure release!

2.4.3 Ground cable

The ground cable is used to prevent sources of ignition through electrostatic charges.

The ground cable is already connected to the unit when it is delivered (e.g. on the high pressure filter, the ground bar, etc.).

Reorder the ground cable immediately (order no.: 0474487) if lost or damaged.



Fig. 3: Ground cable

2.5 Operating and maintenance personnel

2.5.1 Unit owner's duties

The unit owner:

- is responsible for the training of the operating and maintenance staff,
- must instruct the operating and maintenance staff in correct handling of the unit as well as in wearing the correct work clothing and personal protective equipment,
- must provide tools to operating and maintenance personnel such as e.g. lifting equipment for transporting the unit or the containers,
- must make the user manual available to the operating and maintenance staff and ensure that it always remains available,
- must ensure that the operating and maintenance staff have read and understood the user manual.

Only then may the unit be brought into service.

2.5.2 Personnel qualification

A differentiation is made between two groups of people depending on their qualifications:

- Instructed operators have been verifiably instructed by the unit owner in the activities they are tasked with and the potential risks connected with them in the case of incorrect behaviour.
- Trained personnel have been instructed by the unit builder so that they are capable of carrying out maintenance and repair work on the system and recognising potential risks on their own initiative and of avoiding these risks.

2.5.3 Authorized operating personnel

Activity	Qualification
Set-up and operation	Instructed operator
Cleaning	Instructed operator
Servicing	Trained personnel
Repair	Trained personnel



Young persons under the age of 16 are not allowed to operate this unit.

2.5.4 Personal Protective Equipment (PPE)



Wear protective clothing

Always wear the protective clothing specified for your work environment (e.g. antistatic protective clothing in areas subject to explosion hazards) and also follow the recommendations in the safety data sheet issued by the material manufacturer.



Use eye protection

Wear protective goggles to protect against eye injuries caused by material splatter, gases, fumes or dust.



Wear ear defenders

Operating personnel should be provided with suitable noise protection equipment. The unit operator is responsible for adhering to the accident prevention regulation “Noise” (BGV B3). For this reason, pay special attention to the conditions at the installation location – the noise burden, for example, will increase if the unit is installed in or on hollow bodies.



Wear a respiratory protection mask

We strongly recommend that you wear a respiratory protection mask, even though the paint mist has been minimized in the airless spraying method given a correct pressure setting and correct working methods.



Wear protective gloves

Wear antistatic protective gloves. When processing heated materials, you must wear lower arm protection in addition to protective gloves to prevent burns.



Wear protective footwear

Wear antistatic protective footwear to prevent injuries to the feet due to objects that may fall, drop or roll around and to prevent slipping on a slippery floor.

2.6 Notes on warranty



Please note our Terms and Conditions at www.wiwa.de.

2.6.1 Conversions and alterations

- Unauthorized conversions or alterations should not be undertaken on safety grounds.
- Protective equipment should not be dismantled, converted or bypassed.
- The unit must only be operated within the specified limiting values and unit parameters.

2.6.2 Spare parts

- When carrying out maintenance and repair work, you must only use **WIWA** original spare parts.
- Use of components which have not been manufactured or delivered by **WIWA** renders any warranty null and void.

2.6.3 Accessories

- Using original **WIWA** accessories guarantees that they are usable in our units.
- If you use third-party accessories, they must be suitable for the unit – particularly with regard to the operating pressure, the electrical connection data and the connection sizes. **WIWA** accepts no liability for damage or injuries resulting from the use of these parts.
- You must observe the safety regulations of the accessories. These safety regulations are found in the separate operation manual for the accessories.

2.7 Emergency procedures

2.7.1 Stop the unit and release the pressure

In an emergency, immediately shut down the unit and release the pressure.

1. Close the compressed air shut-off valve.
2. Operate the spray gun again briefly to relieve any residual material pressure, ensuring full pressure release for the unit.



This procedure is not suitable for decommissioning. The unit has not been flushed.

- For controlled decommissioning please see Chapter 5.8 Decommissioning on page 44.
- After remedying the emergency, the unit has to be flushed (see Chapter 5.4 Flushing on page 42).
Pay attention to the potlife of the material used.

2.7.2 Leakages



WARNING

In case of leakages material can escape under very high pressure and cause serious bodily injuries and material damage.

- Stop the unit immediately and release the pressure.
- Re-tighten any screw fittings and replace defective components (only by trained personnel).
- Do not try to seal leaks on the connections and high pressure hoses with the hand or by wrapping fabric around them.
- Do not repair material hoses!
- Before recommissioning the unit, check the hoses and screw fittings for leaks.

2.7.3 Injuries

If injured by processing materials or cleaning agents, always have the safety data sheet (address, phone number, material designation and material number of the supplier or manufacturer) ready for the attending physician.

3 Unit Description

The WIWA Airless and hot spray devices are divided into two series which basically differ in the size of the high pressure pumps.

- PROFIT
- PHOENIX
- SUPER
- PROFESSIONAL
- HERKULES

Airless describes a spray method where the spraying material is applied to the surface with high pressure and without the addition of air. The spraying material is atomized only through the material pressure and the nozzle in the spray gun.

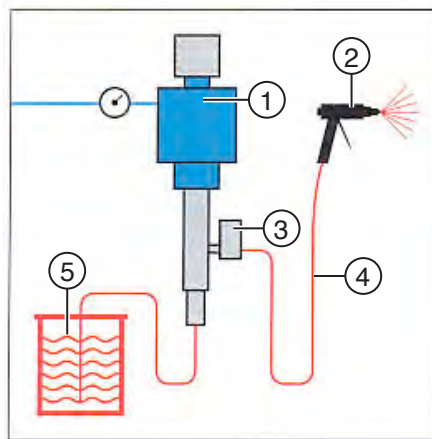

No.	Description
1	Airless spraying equipment
2	Airless spray gun
3	High pressure filter
4	Spraying hose
5	Container with spraying material

Fig. 4: Flow chart for airless operation

For hot spraying, a material flow heater is additionally integrated into the material flow to heat the spraying material to the desired spraying temperature (more information see Chapter 5.3 Hot spraying / operation with material heater on page 39).

The technical data of your unit can be found on the attached unit card or on the type plate.

3.1 Intended use

The WIWA Airless and hot spray devices are only suitable for airless spraying of coating and ancillary materials for surface treatment.



Any other use is considered to be unintended. If you intend to use the unit for other purposes or with other materials and thus not for the purpose for which it is intended, you must ask **WIWA** for permission – otherwise the warranty will be invalidated.



Intended use also includes compliance with the technical documentation and adherence to the prescribed operating, servicing and maintenance guidelines.

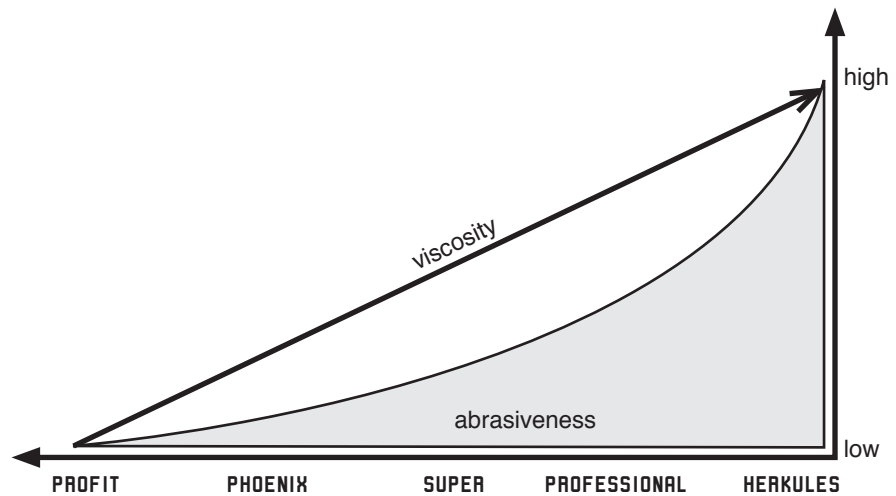

Fig. 5: The Airless series with regard to their suitability with respect to viscosity and abrasiveness of the material

3.1.1 PROFIT SERIES

The devices from the Profit range are portable paint spray devices. They are primarily used in craftsmen workshops, e.g. in carpenters' workshops for coating wood. Due to their portability, the devices are ideal for repair work on surface coatings such as repairs onboard ships.

They are suitable for virtually all sprayable paints and varnishes.

The devices with a pressure ratio of 33 : 1 are also suitable for oils and greases and primers as well as for textured and hammer tone finishes.

Water-based paints and media that can be thinned with water can only be processed in devices with rust-proof and acid-resistant finishes.

Existing Airless spraying equipment can be retrofitted for the Air Combi system.

3.1.2 PHOENIX series

The devices from the Phoenix series are designed for sprayable materials with slightly higher viscosity (e.g. water-based paint). They are suitable for a range of industrial applications.

They are suitable for oils and greases, primers, sprayable fillers, rust protection and micaceous iron oxide paints, dual component materials, textured and hammer tone finishes.

The devices with a pressure ratio of 52 : 1 can also process highly viscous coating materials and are therefore suitable – due to their still compact size – for repair work in corrosion protection, e.g. repair work on construction sites, repairs onboard ships etc.

Low-solvent and solvent-free paints as well as pickles and zinc dust paints can only be processed to a very limited extent.

3.1.3 SUPER series

The Airless paint spraying devices from the **SUPER** series are suitable for spraying sprayable paints and varnishes, highly viscous and coarsely pigmented dual component and tar epoxy paints, cold bitumen and thick film

materials, paints with low or zero cleaning agent content as well as insulants.

The **SUPER** Airless paint spraying device 10066 is a powerful device for efficient coating of large areas and for achieving thick coats. The high pressure ratio of the Super 10066 model provides it with considerable pressure reserves with a low pressure in your air supply.

The **SUPER** Airless paint spraying equipment 15042 with a maximum output of 15.0 l/min is a compact and powerful device for large areas and thick coats.

3.1.4 PROFESSIONAL series

The **PROFESSIONAL** series was designed especially for heavy corrosion protection.

The **models 24026, 24053, 24071, 28023, 28048, 28064** are suitable for processing low to high viscosity, water-based materials with a high solids content and normal, low or zero solvent content.

The devices are also ideal for spraying with longer material hoses and larger nozzle openings as well as for spraying with high pressure.

The **models 38032, 38042, 44024, 44032** were especially developed for applications with coarsely pigmented or abrasive materials of low to medium viscosity e.g. zinc primer, solvent-based zinc silicate, micaceous iron ore, glass flake, printing inks, flame protection and other heavily pigmented or fibrous materials.

The devices have a high output even with large tip openings and slow piston speed while also being subject to only low wear.

They are particularly suitable for use in automatic spraying systems with or without circulation.

3.1.5 HERKULES series

The Airless spraying devices from the **HERKULES** series are particularly suitable for spraying high viscosity and coarsely pigmented dual component and tar epoxy paints, cold bitumen, thick film materials, paints with zero or low solvent content, insulants, anti foulings, glass flake, flame retardants as well as materials with short fibrous fillers.

They are used in large area spraying with high output, for processing thick film coats and in circulation systems.

3.2 Unit design

The machines can be mounted on different frames, e.g. on

- 20 l container
- Frame with hopper and feed drum
- Cart
- Tripod
- Wall Brackets

The frame makes no difference to the function of the unit.

3.2.1 PROFIT series

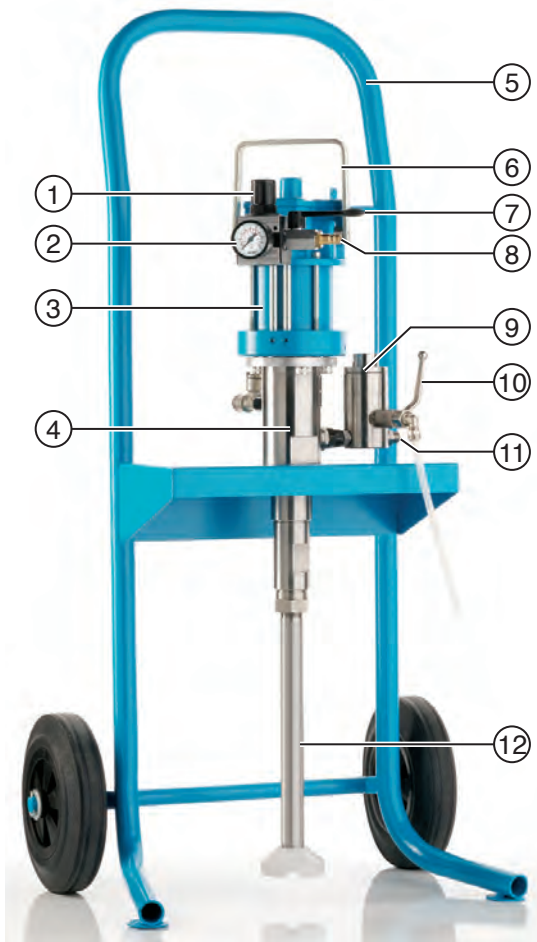

Fig. 6: Profit on cart

No.	Description
1	Compressed air regulator
2	Pressure gauge for displaying the air inlet pressure
3	Air motor
4	Material pump
5	Cart
6	Carrying handle
7	Compressed air shut-off valve
8	Compressed air connection
9	High pressure filter (for more information see Chapter 6.5 High pressure filter on page 50)
10	Relief valve for pressure release
11	Connection for spray gun and spray hose
12	Material inlet/suction (here: suction pipe with suction strainer)



Fig. 7: Profit on container

Design variants:



Fig. 8: Profit on tripod



Fig. 9: Profit on wall bracket

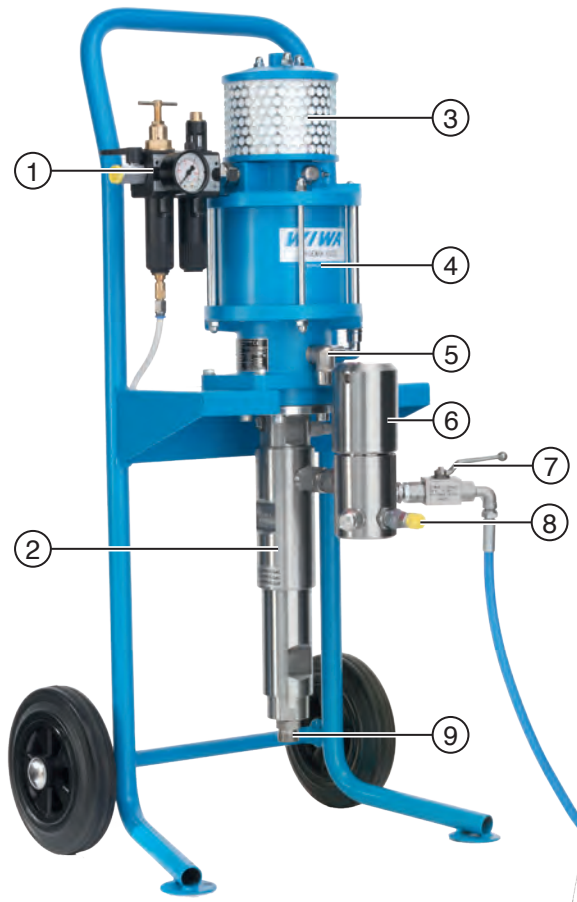

Fig. 10: Profit will feed hopper



Fig. 11: Profit "upside down" (RS-1), alternatively also on cart (see title page)

3.2.2 PHOENIX series



No.	Description
1	Air maintenance unit (see chap. 3.4)
2	Material pump
3	Muffler
4	Air motor
5	Overflow (for more information see Chapter 6.4.2 Checking the release agent for material residue on page 49)
6	High pressure filter (for more information see Chapter 6.5 High pressure filter on page 50)
7	Relief valve for pressure release
8	Connection for spray gun and spray hose
9	Material inlet/suction

Fig. 12: Phoenix on cart



Fig. 13: Phoenix on wall bracket (here as AirCombi device)

Design variants:



Fig. 14: Phoenix with compressed air regulator



Fig. 15: Phoenix with feed hopper



Fig. 16: Phoenix as hot spray unit

3.2.3 SUPER series

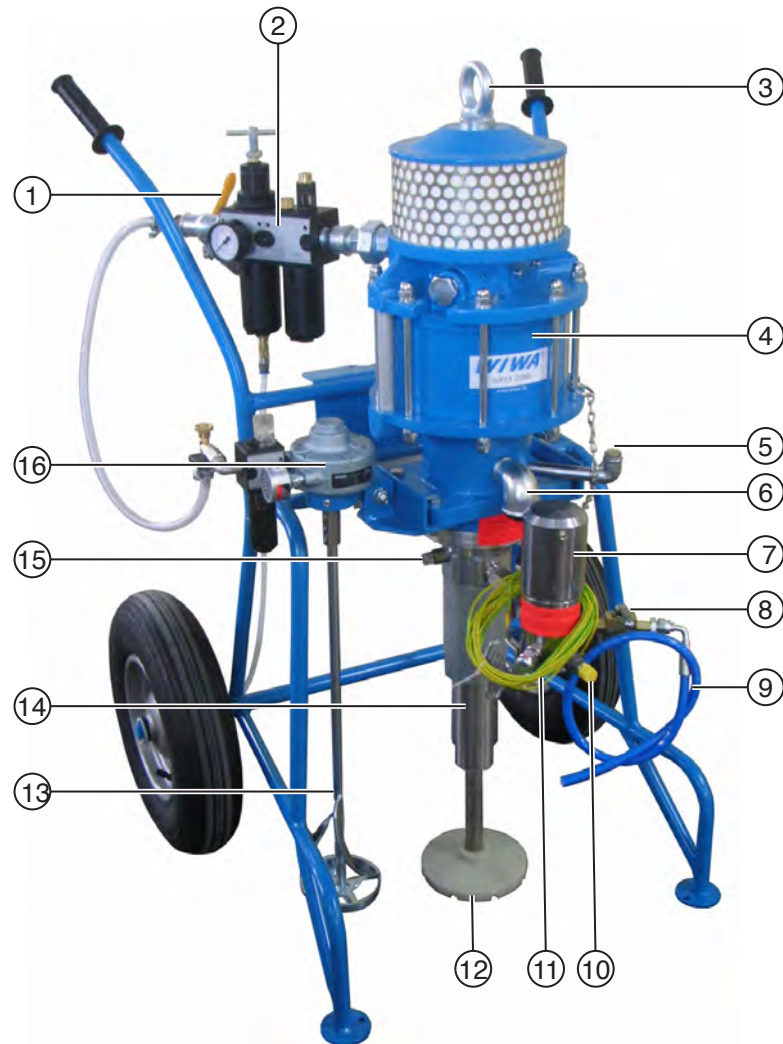

Fig. 17: Super
(here on cart with optional agitator)

No.	Designation
1	Compressed air shut-off valve
2	Air maintenance unit (see chap. 3.4)
3	Crane eyelet
4	Air motor
5	Filler neck for release agent
6	Overflow
7	High pressure filter
8	Relief valve for pressure release
9	Drain hose

No.	Designation
10	Spray hose connection
11	Ground cable
12	Direct suction with sieve
13	Paddle (optional equipment)
14	Material pump
15	Outlet opening for release agent
16	Agitator motor with own compressed air regulator and speed control (all optional equipment)

3.2.4 PROFESSIONAL series



Fig. 18: PROFESSIONAL (here on cart)

No.	Designation
1	Air maintenance unit (see chap. 3.4)
2	Compressed air shut-off valve
3	Air motor
4	Material pump
5	Crane eyelet
6	Filler neck for release agent
7	Overflow

No.	Designation
8	High pressure filter
9	Relief valve for pressure release
10	Drain hose
11	Spraying hose
12	Ground cable
13	Spray gun
14	Material intake with sieve

3.2.5 HERKULES series



Fig. 19: Overall view of an Airless HERKULES (here on cart)

No.	Designation
1	Air maintenance unit (see chap. 3.4)
2	Compressed air shut-off valve
3	Muffler
4	De-icing (optional)
5	Air motor
6	Filler neck for release agent
7	Overflow

No.	Designation
8	High pressure filter
9	Relief valve for pressure relief with hose
10	Spraying hose
11	Material pump
12	Spray gun
13	Material intake with sieve

3.3 Compressed air regulator

The compressed air regulator controls the air inlet pressure for the air motor of the high pressure pump. The ideal setting depends on many factors, e.g. the texture of the material (viscosity, temperature, etc.) and the desired spray pattern. You will be able to determine the suitable air inlet pressure for your application during operation. The information in Chapter 5.2.1 Adjusting the spraying pressure on page 38 and Chapter 5.2.2 Advice for achieving good coating results on page 39 will help with this.



The devices from the **SUPER**, **PROFESSIONAL** and **HERKULES** series as well as some devices from the **PHOENIX** series are equipped with an air maintenance unit (see Chapter 3.4 Air maintenance unit on page 28) into which the compressed air regulator is integrated.

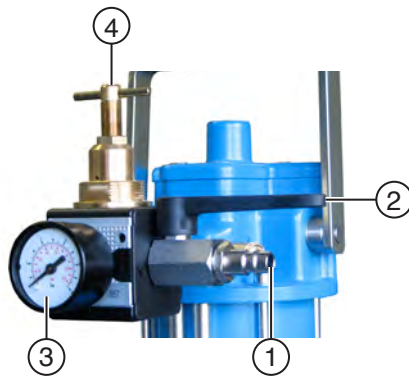

Fig. 20: Compressed air regulator on Profit

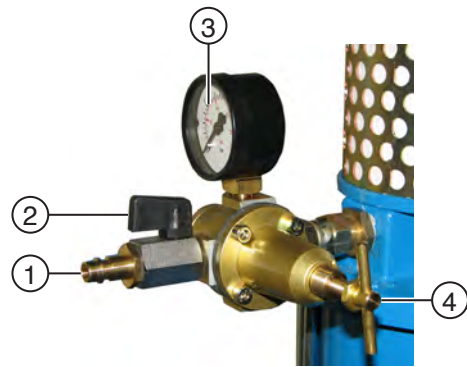

Fig. 21: Compressed air regulator on Phoenix

No.	Designation
1	Air connection
2	Compressed air shut-off valve
3	Pressure gauge for displaying the air inlet pressure
4	Compressed air regulator

How to operate the compressed air regulator:

- Turn clockwise to increase the pressure,
- turn counter clockwise to reduce the pressure.

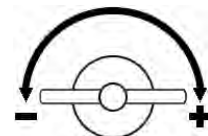

Fig. 22: Function air regulator

3.4 Air maintenance unit



The devices from the **PROFIT** series and some devices from the **PHOENIX** series are only equipped with a compressed air regulator (see Chapter 3.3 Compressed air regulator on page 27). They do not have a maintenance unit.

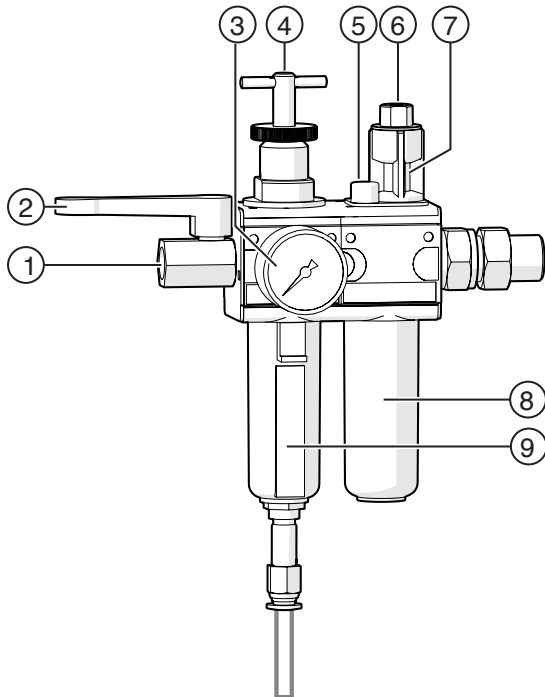

Fig. 23: Maintenance unit on PHOENIX and PROFESSIONAL series

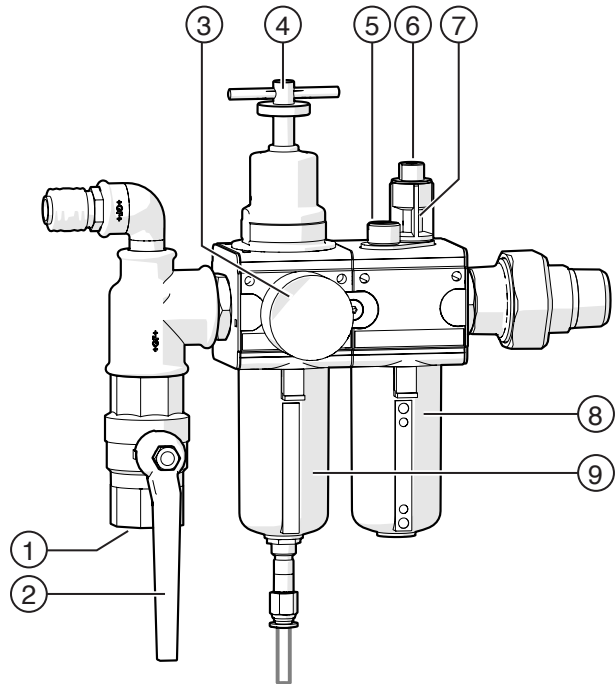

Fig. 24: Maintenance unit on the PROFESSIONAL and HERKULES series

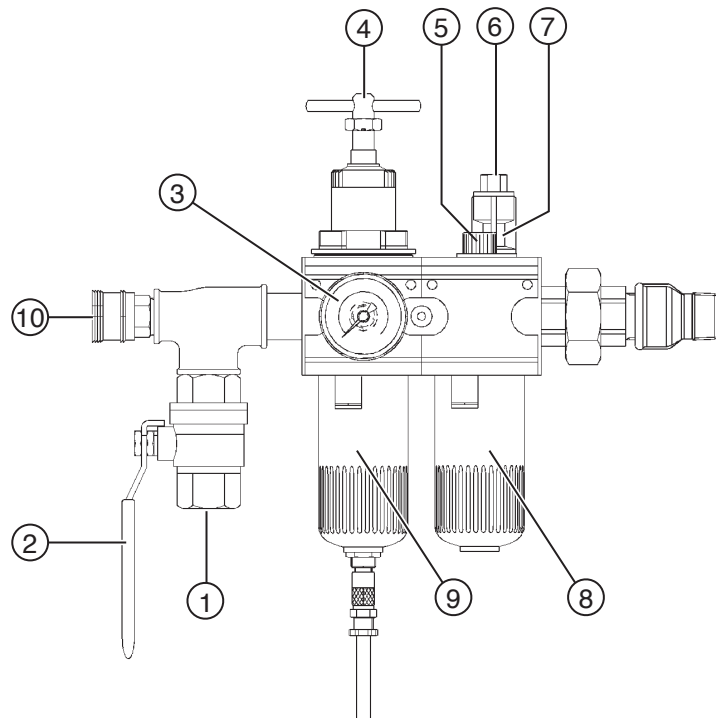

Fig. 25: Maintenance unit on the SUPER series

No.	Designation
1	Air connection (G $\frac{3}{8}$ " for fig. 22, 1" for fig. 23)
2	Compressed air shut-off valve
3	Pressure gauge for displaying the air inlet pressure
4	Compressed air regulator
5	Oil filler plug
6	Setting screw for controlling the oil addition
7	Inspection glass
8	Oil tank
9	Water separator with automatic drain valve
10	Compressed air distributor for connecting further compressed air driven equipment

3.5 Optional accessories and expansion parts

The following section lists only some of the most common accessories and expansion parts.

The detailed accessory catalogue can be found at www.wiwa.de. More information and order numbers can also be obtained from an authorized WIWA dealer or the WIWA service department.

3.5.1 Spraying accessory kits

The spraying accessories are not part of the standard scope of delivery as the variety of the materials used and the applications is too great. Select

the spraying accessories that are best suited to your application to create a spraying accessory kit.

The spraying accessory kits contain

- Airless spray gun
- Spraying hose
- Standard or reversing nozzle



Observe and follow the separate operation manual for the spray gun.

3.5.2 Material flow heater

Material flow heaters can optionally be used as:

- Heaters for the spraying material (see Chapter 5.3 Hot spraying / operation with material heater on page 39)
- Auxiliary heaters for long hoses
- Heating the spraying air for Air Combi spraying (see separate operation manual)
- Heating the air for the air motor to prevent icing over



Observe and follow the separate operation manual of the material flow heater.

3.5.3 Agitator

As many coating materials contain solids, it can be practical to use an agitator to create as much homogeneity as possible in the supplied container.

The agitators are as varied and diverse as the actual coating materials.



Observe and follow the separate operation manual of the agitator.

3.5.4 De-icing

The de-icing mounting kit can be optionally used on **PROFESSIONAL** and **HERKULES** to reduce icing over of the air motor during operation. The efficiency of the de-icing can be further increased by adding a material heater.

1. Slowly turn the control screw counter-clockwise to open the de-icing.
We recommend:
min. 1 turn
max. 3 turns



Fig. 26: Adjusting screw for de-icing

Exact settings should be made individually and as required because the

degree of icing over depends on various factors (e.g. pressure, number of double strokes per minute, humidity, ambient temperature).



The de-icing remains open during work breaks and decommissioning.

3.5.5 Material return flow control

A material return flow control is used wherever materials are to circulate, e.g. for hot spraying processes in order to keep the material at a constant temperature or for filled materials to prevent settling.

The material return flow control will open with the spray gun closed through the pressure building up in the spray or return line. Follow the operating information in Chapter 5.3.2 Operation with material heater with circulation on page 41.

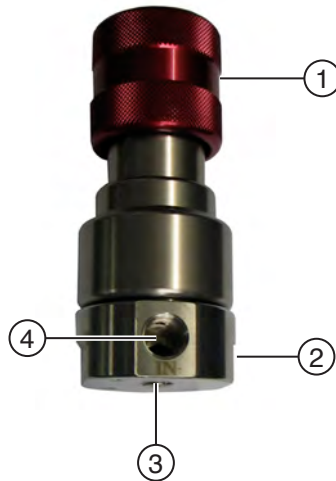

No.	Description
1	Pressure control
2	Material outlet (covered) G 3/8"
3	Pressure gauge connection (optional)
4	Material inlet G 3/8"

Specifications for material return flow control:	
max. operating pressure:	400 bar (5800 psi)
controllable pressure range:	50 - 400 bar
temperature range:	4,5 - 100 °C
max. feed volume:	13,3l/min. (3,5 gal./min.)

Fig. 27: Material return flow control

4 Transport, installation and assembly

The unit left the factory in flawless condition and was appropriately packed for transportation.



Check the unit on receipt for any damage in transit and for completeness.

4.1 Transportation

Please follow these notes when transporting the unit:

- Ensure sufficient load bearing capacity of lifting gear and lifting tackle when loading the unit. The dimensions and weight of the unit can be found on the unit card or on the type plate.
- Use the handle to lift units from smaller series (Profit, Phoenix). For the larger series (Professional, Herkules), attach suitable lifting equipment to the dedicated lifting eyes (see e.g. Fig. 17, no. 3). The lifting eyes are only designed for the weight of the high pressure pump. Do not use them to lift the entire machine (including accessories, hoses or frame)!
- Secure the unit (high pressure pump including frame and/or other accessories) properly for lifting and loading the unit.
- Do not transport any unsecured objects (e.g. material containers, tools) with the unit.
- Never stand under suspended loads or inside the loading area. There is a risk of death!
- Secure the load on the transport vehicle against slipping and falling off.

If the unit had already been in operation, please observe the following:

- Disconnect the entire unit power supply – even for short transportation distances.
- Empty the unit before transportation – fluid residues may escape during transportation despite this measure.
- Remove all loose components (e.g. tools) from the unit.

4.2 Installation location

The unit can be installed inside and outside spray booths. However, outside installation should be preferred in order to avoid contamination.



WARNING

If the unit is used outside during a thunderstorm, a lightning strike can cause a life-threatening situation for the operating personnel.

- Do not operate a unit outdoors during a thunderstorm!
- The unit owner must ensure that the unit is equipped with suitable lightning protection equipment.



Set the unit up horizontally on a foundation that is flat, firm and vibration-free. The unit must not be tipped or tilted. Ensure that all operating elements and safety features are easy to reach.

Safety measures at the place of installation:

- This unit requires a solid base and sufficient free space for safe operation.
- Always keep the working area, especially all walkways and standing areas, clean and tidy. Immediately remove any spilled material and cleaning agent.
- Always ensure adequate ventilation at the work place to avoid damage to health and material objects. Always ensure an air change rate of at least 5.
- Always observe the processing instructions issued by the material manufacturers.
- Even though there are no legal directives for low-mist Airless spraying methods, all hazardous solvent vapours and paint particles must be extracted.
- Protect objects adjacent to the spraying object against possible damage caused by the material mist.

4.3 Assembly



WARNING

If assembly work is carried out by people who have not been trained for this work, they endanger themselves and other people and impair the safety and reliability of the unit.

- Electrical components must only be mounted by trained qualified electricians – with all the other components, e.g. the spray hose and the spray gun being assembled by trained personnel only.



WARNING

Sources of ignition may result from assembly work (e.g. through mechanical sparks, electrostatic charge, etc.).

- Carry out all installation and maintenance work outside of areas with explosive atmospheres.

4.3.1 Mounting the wall bracket (optional)

The unit can optionally be mounted on a wall bracket.

Observe the weight of the unit (see Technical data) and select suitable fastening materials, taking into account the wall structure. We recommend at least screws M12 with strength category 8.8.

Ensure a sufficient distance between suction elbow and floor of at least 10 cm.

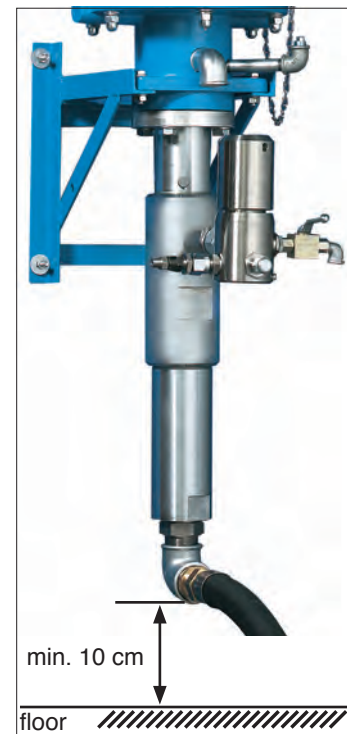

Fig. 28: Mounting the wall bracket

4.3.2 Assembling spray hose and spray gun



WARNING

Components that do not comply with the maximum permitted operating pressure of the unit can burst and cause serious injury.

- Check the maximum permitted operating pressure of the material hose and the spray gun before assembly. It must be greater than or equal to the maximum operating pressure of the unit as specified on the type plate.

1. Connect the spraying hose to the material outlet on the high pressure filter (see Fig. 30).
2. Connect the spray gun to the spraying hose (see Fig. 29).



Fig. 29: Connecting spray gun to spray hose



Fig. 30: Connecting spraying hose to high pressure filter

4.3.3 Grounding the unit



WARNING

The high flow velocities associated with the Airless spraying method may cause electrostatic charging. Static discharges can cause fire and explosion.

- Ensure that the unit has been properly grounded outside of explosive atmosphere areas!
- Also ground the object to be coated.

1. Connect the ground cable of the unit to an electrically conductive object outside explosive atmosphere areas.
2. Ensure proper grounding of the object to be coated.

4.3.4 Connecting the compressed air supply



The compressor capacity must match the air requirements of the unit and the diameters of the air supply hoses must match the connections such that an adequate air supply is ensured.



Operation with contaminated or moist compressed air causes damage to the unit's pneumatic system.

- Use only dry dust- and oil-free air!

1. Make sure that
 - the compressed air shut-off valve is closed,
 - the air regulator has been turned down fully.
2. Connect the air hose to the compressed air connection of the compressed air regulator or of the maintenance unit (depending on model) (see following figure).

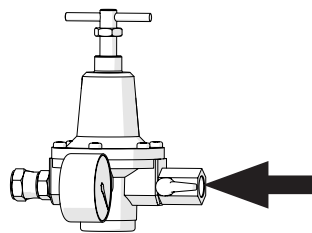

Fig. 31: Connecting compressed air to the compressed air regulator

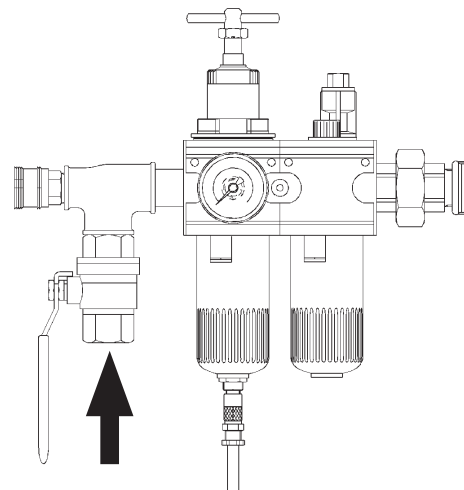

Fig. 32: Connecting compressed air to the maintenance unit on SUPER series

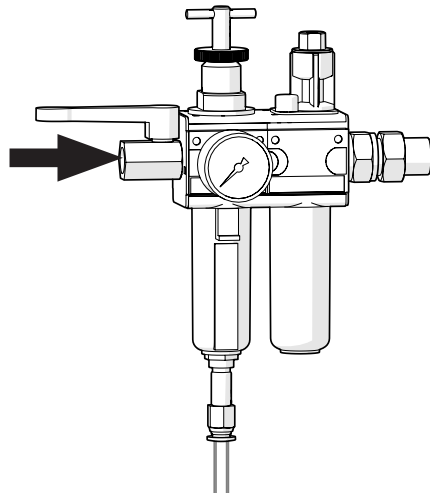

Fig. 33: Connecting compressed air to the maintenance unit on PHOENIX and PROFESSIONAL series

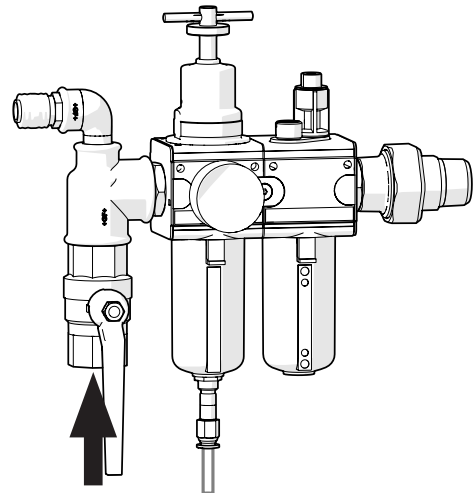

Fig. 34: Connecting compressed air to the maintenance unit on PROFESSIONAL and HERKULES series

5 Operation

- The unit must have been set up correctly and completely assembled.
- Do not start commissioning the unit unless you have the specified protective equipment. For more details, refer to Chapter 2.5.4 Personal Protective Equipment (PPE) on page 16.
- A sufficient quantity of the spraying material has to be available.



Observe the information from the respective material manufacturer.

- You will need:
 - 1 collecting vessel (electrically conductive) for excess material. This container is not included in the scope of delivery.



WARNING

If material pumps run dry, the generated friction heat can cause fire or an explosion.

- Always make sure that the material drums do not run dry during operation. Therefore never leave the unit running unattended.
- However, should this happen, stop the corresponding pump immediately and feed material.

5.1 Commissioning the unit

- Check whether all safety features are installed and fully operational.
- Before initial commissioning, remove the adhesive label “Remove before use” or the vent plug from the overflow.
- Check the level of lubricant in the oil container of the air maintenance unit (if fitted) and top up if required.
- Check the level of release agent on the pump and top up if necessary (see chapter 6.4.1 on page 49).
- Flush the unit (see Chapter 5.4 Flushing on page 42) to remove the factory test medium (for first operation) or any residue of previous spraying material.
- During commissioning (flushing), check whether all unit parts are tight and re-tighten the connections if required.
- Ensure proper grounding of the unit and the object to be coated (see Chapter 4.3.3 Grounding the unit on page 35).

5.2 Spraying

The following steps for commissioning have to be completed before spraying (see Chapter 5.1 Commissioning the unit on page 37).

1. Place the suction into the spraying material or fill the hopper.
2. only for special “upside down” model (RS-1): When filling the hopper, simultaneously press the bleed valve below the hopper to fill the material pump and bleed the device.

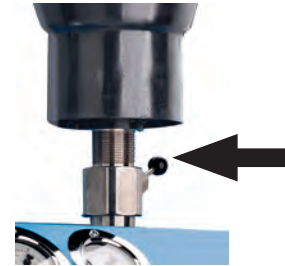

Fig. 35: Relief valve on RS-1

3. Regulate the air inlet pressure so low that the pump runs slowly.
4. Unlock the spray gun and operate it until clean spraying material runs out. Hold the spray gun laterally against the inner wall of the collecting vessel.
5. Set the best possible spraying pressure on the compressed air regulator (see chapter 5.2.1).

5.2.1 Adjusting the spraying pressure

Please observe the following information when adjusting the spraying pressure:

- Optimal spraying pressure is indicated by a uniform application of material with fading out peripheral zones.
- Operate the unit only with an air pressure as high as necessary, to achieve good atomisation at the recommended spraying distance of approx. 30-40 cm.
- Excessive spraying pressure causes increased material consumption and paint mist.
- Insufficient spraying pressure results in the appearance of streaks and differences in the coating thickness.

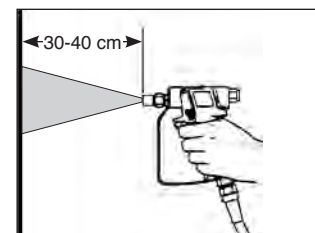

Fig. 36: Spraying distance



Observe the operation manual for your spray gun. It contains more useful information for optimising the spraying result.

5.2.2 Advice for achieving good coating results

- Hold the spray gun at a right angle (90°) to the area to be coated. If the spray gun is held at a different angle, the coating becomes irregular and blotchy (Fig. 37).
- Ensure even speed and move the spray gun parallel to the area to be coated. Waving the spray gun causes irregular coating (see Fig. 38).
- Move the spray gun with your arm and not with your wrist.
- Start moving the spray gun before pulling the trigger. That way, you will achieve perfect, soft and smooth overlapping of the spray jet and avoid excessively thick application of material at the beginning of the spraying process.
- Release the trigger before stopping the movement.
- Replace the spray nozzle before it is worn.

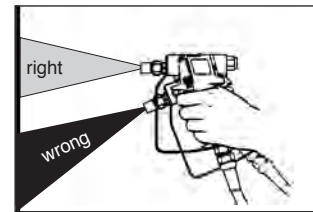

Fig. 37: Spray angle

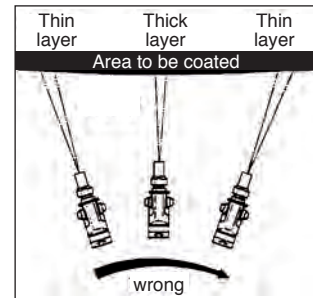

Fig. 38: Do not wave!



Worn nozzles cause higher material consumption and have a negative effect on the quality of coating.

5.3 Hot spraying / operation with material heater

During hot spraying, the spraying medium is heated to the desired spraying temperature using a material flow heater (see Fig. 39).

The material can be heated in circulation or as a mere pass-through process.

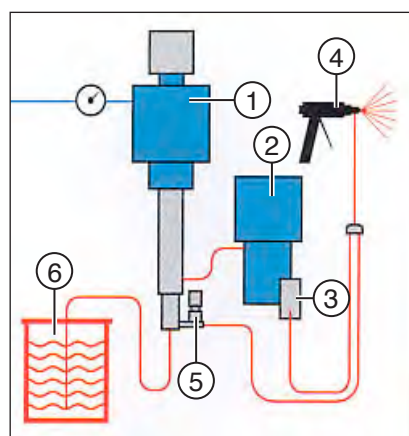

Fig. 39: Flow chart for using a material heater with circulation

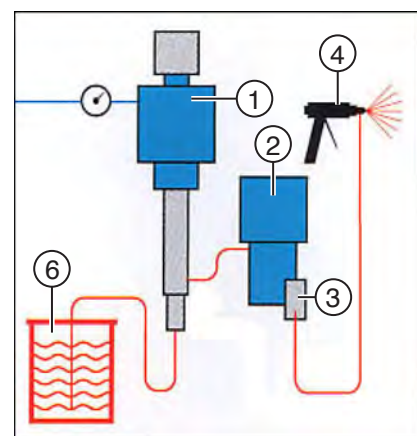

Fig. 40: Flow chart for using a material heater without circulation

No.	Description
1	Airless spraying equipment
2	Material flow heater
3	High pressure filter
4	Airless spray gun
5	Material return flow control (only with circulation)
6	Container with spraying material

With circulation the process is as follows:

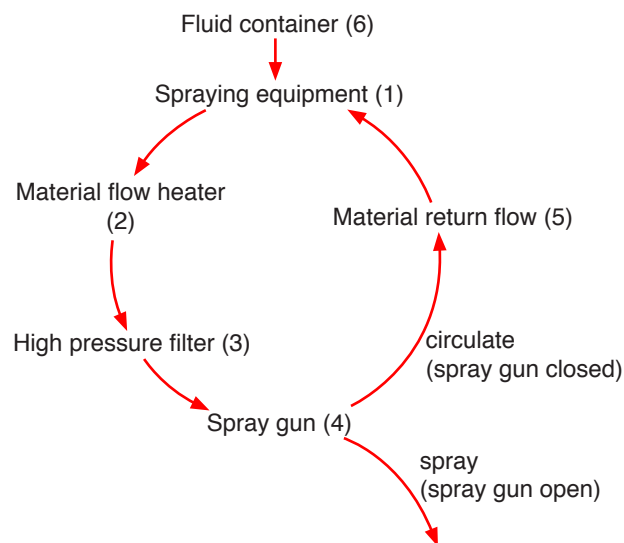

Fig. 41: Circulation during hot spraying



Fig. 42: Material flow heater

The material is pumped from the fluid container into the spraying equipment. From there it is transferred to the material flow heater and heated. It then flows through the high pressure filter to the spray gun. If the spray gun is not actuated, the material return flow control opens and the material flows back into the spraying equipment.

This circulation achieves a constant material temperature – even during a work interruption.



WARNING

Heating up materials containing solvents can cause an explosion. This may result in serious injury to persons and damage to property.

- Pay attention to the flashpoint and the ignition temperature of the materials used.
- Switch off the material flow heater if you need to perform the following work: Cleaning, pressure testing, decommissioning, maintenance and repair.



CAUTION

When using a material flow heater, contact with hot material or hot surfaces can cause burns on hands and arms.

- Always wear protective gloves!



Observe and follow the separate operation manual of the material flow heater.

5.3.1 Adjusting the operating pressure

The material flow heater has a permitted operating pressure of 450 bar (see Technical data of the material flow heater).

The permitted operating pressure of the Airless device can be higher than this value, depending on the type of device. In this case, replace the safety valve of the Airless device with a smaller one.

Determine the maximum permitted air inlet pressure for the spraying equipment.

$$\text{max. air inlet pressure} = \frac{450 \text{ bar}}{\text{Pressure ratio}}$$

5.3.2 Operation with material heater with circulation



Please note the pot life of the material to be processed.

Remember that the pot life is shortened through heating. Rule of thumb: the pot life is halved for each 10° of temperature increase.

Material hardening in the return flow may occur (circulation).

- Close the spray gun at short intervals during coating so the material is circulated and does not remain in the return line for too long.

1. Let the spraying material circulate while cold before switching on the material flow heater.
2. Adjust the pressure on the material return flow control so that the pump works with approx. 5 double strokes per minute with the spray gun closed.



Symbol	Description
-	Decrease pressure
+	Increase pressure

Fig. 43: Set pressure on the material return flow

5.3.3 Operation with material heater without circulation



Please note the pot life of the material to be processed.

Remember that the pot life is shortened through heating. Rule of thumb: the pot life is halved for each 10° of temperature increase.

1. After switching on the material heater, spray the not yet heated material from the spray hose before starting the coating process.

5.4 Flushing

Flushing the unit is necessary:

- At initial and re-commissioning the unit has to be flushed with a cleaning agent to ensure that the spraying material is not negatively affected by the test medium that was used at the factory to test correct functioning.
- When changing materials
- For terminating work and at decommissioning in the case of an interruption in spraying to flush spraying material out of the unit before it sets.



Take note of the potlife of the materials used, particularly when using two-component materials.



WARNING!

When using material heaters:

Heating up materials containing solvents can cause an explosion. This may result in serious injury to persons and damage to property.

- Before flushing the unit, switch off the material flow heater (optional) and leave it to cool completely.
- You will need:
 - at least 5 l of cleaning agent suitable for the processed material and recommended by the material manufacturer, in an open container
 - an additional collecting vessel for the cleaning agent that is flushed out.
 These containers are not supplied.

1. Close and secure the spray gun.
2. Regulate the air inlet pressure down all the way on the air regulator. The pressure gauge has to show 0 bar.
3. Relieve the pressure (see Chapter 5.6 Releasing pressure on page 44).
4. Remove the nozzle from the spray gun. Observe and follow the notes in the user manuals for the spray gun.
5. Remove the filter element from the high pressure filter (Chapter 6.5 High pressure filter on page 50).

6. Remove the suction pipe from the material container.
Scrape off any paint residue.
or: Empty the hopper by letting the remaining material run out through the relief valve.
7. Place the suction pipe into the container with the cleaning agent.
or: Fill the hopper with solvent.
8. Open the compressed air shut-off valve.
9. Regulate the air inlet pressure low enough so that the pump runs slowly.
10. Open the relief valve on the high pressure filter until pure cleaning agent is emitted. Hold the hose in a collecting vessel during this.
11. Close the relief valve.
12. Hold the spray gun laterally against the inner wall of the collecting vessel.
13. Open the spray gun until pure cleaning agent is emitted.
14. Close and secure the spray gun.

5.4.1 Cleaning the material return flow control (optional)

The chapter describes additional work steps for operating the device with circulation.

1. Carry out the flushing process as described in Chapter 5.4 Flushing on page 42.
2. Close all relief valves on the device and the spray gun.
3. Let the cleaning agent circulate briefly through the material return flow control.
4. Close the material return flow control.
5. Open the relief valve on the high pressure filter and let the remaining cleaning agent drain off.

5.5 Material change

1. Flush the unit as described (see Chapter 5.4 Flushing on page 42).
2. Drain the unit by removing the suction pipe from the cleaning agent and opening the spray gun until air is emitted.
3. Close and secure the spray gun.
4. Fully reduce the air inlet pressure (0 bar).
5. Release the pressure in the device (see Chapter 5.6 Releasing pressure on page 44).
6. Check the filter element in the high pressure filter (see chapter 6.5 on page 50).
7. After finishing the task you can start spraying a new material (see chapter 5.2 on page 38).

5.6 Releasing pressure

1. Close the compressed air shut-off valve.
2. To release the pressure:
 - open the relief valve on the high pressure filter
 - remove the spray gun



CAUTION

If parts of the unit (e.g. spray nozzle, material filter on the spray gun, material hose, high pressure filter, suction strainer, etc.) are clogged the pressure cannot be fully released. Residual pressure could be released during disassembly work and cause severe injuries.

- Cover the screw fitting with a rag during releasing to protect yourself against sudden release of material.
- Release the screw fittings very carefully and release the pressure slowly.
- Remove the obstructions (see fault table in Chapter 7 Rectification of faults on page 53).

5.7 Work breaks

Always secure the spray gun, even for shortest work breaks. Secure the spray gun for short work breaks.



Take note of the potlife of the materials used, particularly when using multi-component materials.

The system has to be flushed and cleaned completely with the stipulated cleaning agent within the potlife indicated by the manufacturer. Please note:

- Curing time is reduced at higher temperatures.
- Allow the cleaning agent to circulate for a while.
- No paint residue may remain in the pump or in the filter.

5.8 Decommissioning

If you want to decommission the system for a longer period of time, proceed as follows:

1. Flush the unit as described (see Chapter 5.4 Flushing on page 42).
2. Do not drain the pump fully.
Turn down the operating pressure fully (0 bar) as soon as clean solvent is emitted from the spray gun or the high pressure filter.
3. Hold the spray gun laterally against the inner wall of the collecting vessel and open it again.
4. Hold the drain hose into the collecting vessel and open the relief valve briefly to release the pressure.

The cleaning agent which is still in the unit remains in the unit until recommissioning to prevent the unit parts from sticking.

For longer idle times the unit has to be filled with a release oil as the cleaning agent will evaporate over time.

5.9 Disposal

- ▶ Rests of spraying material, cleaning agent, oils, greases and other chemical substances must be collected in accordance with statutory provisions concerning recycling and waste disposal. The official local waste water laws apply.

At the end of use, you must shut down and dismantle the unit and dispose of it in accordance with legal regulations.

- ▶ Clean the unit thoroughly of all material residues.
- ▶ Dismantle the unit and separate all materials – dispose of metal together with scrap metal; plastic parts can be disposed of as domestic waste.

6 Maintenance



WARNING

If maintenance and repair work is carried out by persons who have not been trained for this work, they endanger themselves and other people and impair the safety and reliability of the unit.

- Maintenance and repair work on electrical components may only be carried out by trained electricians – any other maintenance and repair work has to be performed by **WIWA** customer service or by specially trained personnel.

Before maintenance and repair work:

1. Cut off the compressed air supply.
2. Relieve all pressure in the unit.



CAUTION

If parts of the unit (e.g. spray nozzle, material filter on the spray gun, material hose, high pressure filter, suction strainer, etc.) are clogged the pressure cannot be fully released. Residual pressure could be released during disassembly work and cause severe injuries.

- Cover the screw fitting with a rag during releasing to protect yourself against sudden release of material.
- Release the screw fittings very carefully and release the pressure slowly.
- Remove the obstructions (see fault table in Chapter 7 Rectification of faults on page 53).

After completing maintenance and repair work, check the function of all the safety features and that the unit is functioning correctly.

6.1 Regular inspections

The unit has to be examined and serviced by an expert regularly:

- before initial commissioning,
- after the modification or repair of parts of the system, which could affect safety,
- after work breaks longer than 6 months,
- but at least every 12 months.

For decommissioned units, the inspection can be postponed until the next commissioning.

The inspection results must be recorded in writing and kept until the next inspection. The inspection report or a copy of it must be available at the place of use of the unit.

6.2 Maintenance plan



The information in the maintenance plan is a recommendation. The intervals may vary depending on the texture of materials used and external influences.

Interval	Activity	Reference
before each start-up	Check the lubricant level in the fog oiler	see chapter 6.3.1 on page 48
	Check the release agent level in the high pressure pump	see chapter 6.4.1 on page 49
1 x per week	Checking and adjusting the fog oiler	see chapter 6.3.2 on page 48
	Checking and cleaning the water separator	see chapter 6.3.3 on page 48
	Visual inspection of the compressed air and material hoses	
every 50 operating hours	Check release agent of the high pressure pump for material residue	see chapter 6.4.2 on page 49
every three years	Inspection of the compressed air and material hoses by an expert and replacement if necessary	

6.3 Maintenance unit

The air maintenance unit prevents condensate and dirt particles from entering the machine and supplies the compressed air with pneumatic oil for lubricating moving parts.

The maintenance unit is equipped with the following maintenance elements:

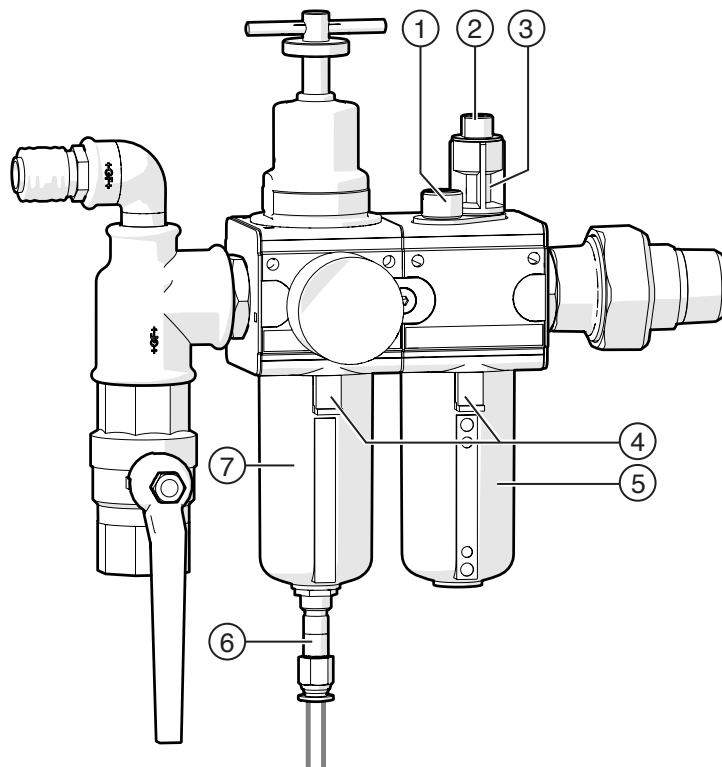

Fig. 44: Maintenance elements (same on all maintenance units)

No.	Designation
1	Filler hole for pneumatic oil
2	Setting screw for metering the oil addition
3	Inspection glass
4	Slide for opening the containers
5	Oil tank
6	Automatic condensate drain valve
7	Water separator

6.3.1 Checking the lubricant level in the fog oiler



The unit must only be commissioned if the oil reservoir of the fog oiler contains enough oil. In case of high humidity, use antifreeze for lubrication to avoid icing of the unit.

Check the lubricant level every day as follows:

1. Press up the locking slide on the oil reservoir and unscrew the oil reservoir by turning it anti-clockwise.



Take care of the O-ring that seals the oil reservoir. It may be displaced or even fall out at dismantling.

2. Check whether the O-ring fits correctly – if necessary, fit it correctly.
3. Check whether there is enough lubricant – at maximum level the lubricant reaches to a point approx. 2 cm below the upper edge of the oil reservoir.
4. Top up lubricant, if necessary.
We recommend using pneumatic oil (order number 0632579) or anti-freeze (order number 0631387) from **WIWA**.
5. Reattach the oil reservoir to the air maintenance unit.

6.3.2 Checking and adjusting the fog oiler

1. Let the unit run slowly under load.
2. Check in the fog oiler inspection glass whether 1 drop of lubricant is fed after each 10 to 15 double strokes of the air motor.
3. If this is not the case, adjust the metering by turning the regulating screw on the fog oiler with a screwdriver.

6.3.3 Checking and cleaning the water separator

The accumulated condensation water is automatically drained off through the drain valve. For this purpose hold the hose into an empty collecting vessel.

Check the bowl regularly for dirt residues and clean it as required.

6.4 High pressure pump

6.4.1 Topping up release agent

Before each start-up check the release agent level as far as possible. Top up release agent if required (see item 1 on Fig. 45 ff.).

The total fill volume is 50 (PROFIT) to 150 ml (HERKULES) depending on pump size.

6.4.2 Checking the release agent for material residue

Regularly check the release agent for discolouration caused by spraying material.

Drain a small amount of release agent through the drain screw (2).

If the release agent is found to be contaminated with material residues, you must assume that the packing of the material pump in question is worn.

The pump packing is certainly worn if material escapes from the overflow (3) (only for PROFESSIONAL and HERKULES).

In this case, have the pump packing replaced as soon as possible.

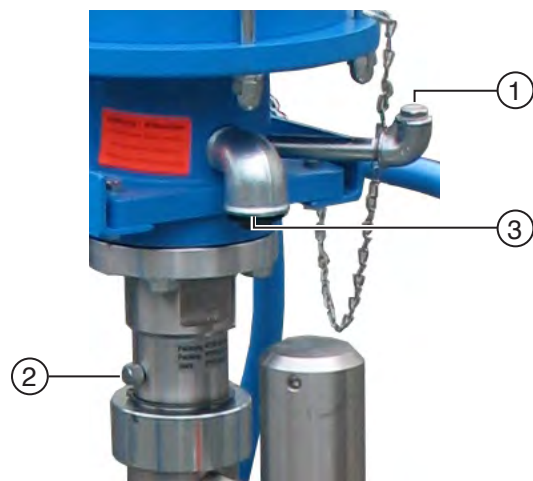

Fig. 45: Filling (1) and draining (2) release agent for PROFESSIONAL and HERKULES

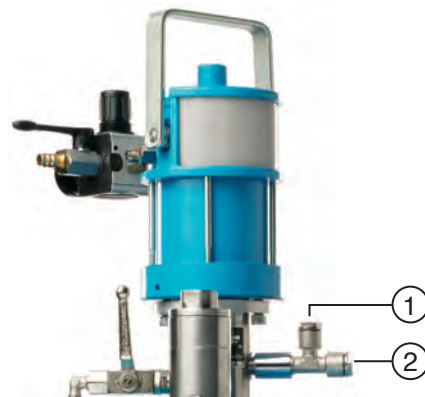

Fig. 46: Filling in (1) and draining (2) release agent for PROFIT

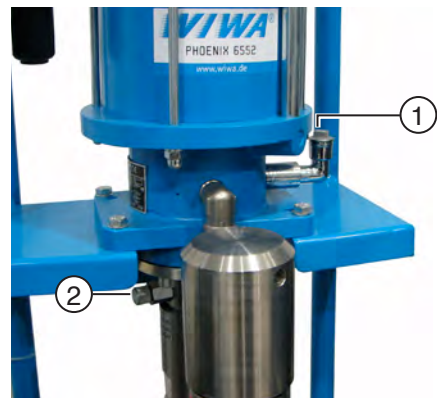

Fig. 47: Filling in (1) and draining (2) release agent for PHOENIX and SUPER



CAUTION

The pump packing may only be replaced by trained personnel or by the WIWA service.

After the examination, top up the amount of fresh release agent through the filler opening (1). We recommend using release agent from WIWA (order number 0163333).

6.5 High pressure filter



WARNING

If the unit was not depressurized when opening the high pressure filter, material may escape under very high pressure and cause serious injuries.

- ▶ Depressurize the unit fully before opening the high pressure filter (see Chapter 5.6 Releasing pressure on page 44)!

6.5.1 Removing the filter element

Different high pressure filters are used for the different Airless series. The unit card indicates which high pressure filter is used in your device.

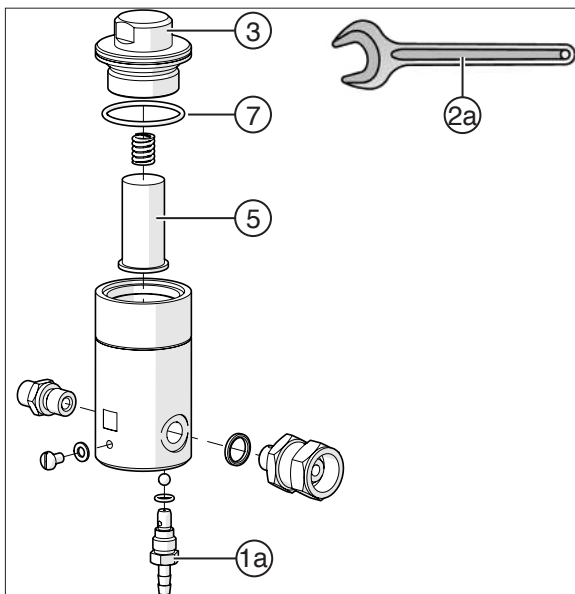

Fig. 48: Removing the filter element for high pressure filter type 01

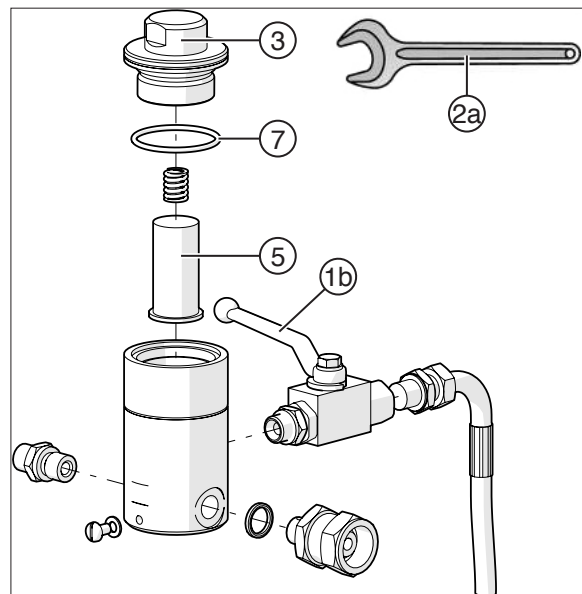

Fig. 49: Removing the filter element for high pressure filter type 05

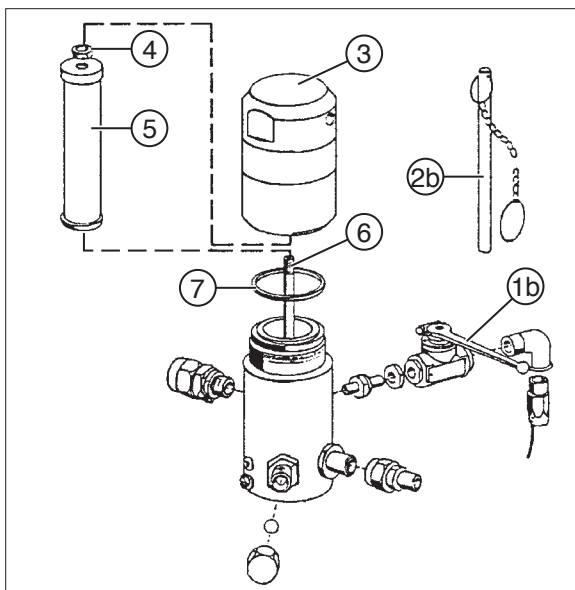

Fig. 50: Removing the filter element for high pressure filter type 11

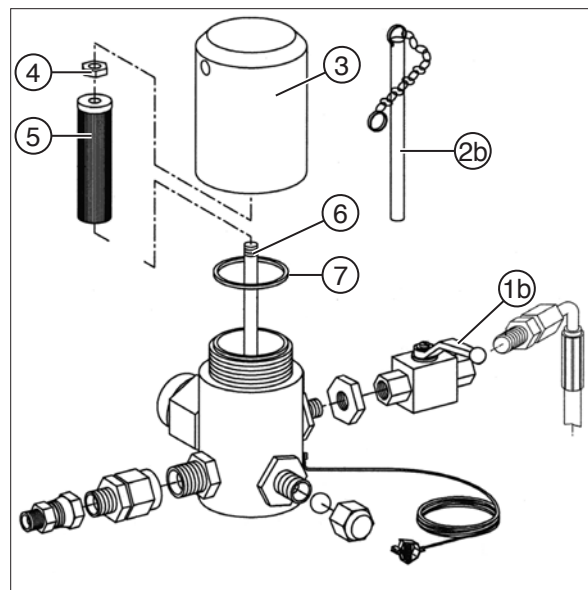

Fig. 51: Removing the filter element for high pressure filter type 13

No.	Designation	
1	a	Drain screw
	b	Discharge ball valve
2	Supplied tools	
	a	Open-end wrench
	b	Pin spanner
3	Cap	
4	Nut	
5	Filter element	
6	Threaded bolt	
7	O-ring	

1. Open the drain screw (1a) or the drain shut-off valve (1b) to ensure that the unit is fully depressurized.
2. for types 01 and 05: Use the open-end wrench (2a) to unscrew the cap (3) from the high pressure filter.

for types 11 and 13: Use the pin spanner (2b) to remove the cap (3) of the high pressure filter and remove it.
3. Loosen the nut (4) and remove the filter element (5).

6.5.2 Cleaning the filter element

The cleaning interval for the filter element in the high pressure filter depends on the type and cleanliness of the material. Clean the filter element at least once a week and after each material change.

1. Remove the filter elements according to Chapter 6.5.1 Removing the filter element on page 50.
2. Clean the filter element. Use only cleaning agents for this purpose that match the material to be applied. Replace the filter element if it shows any damage.
3. Place the filter element back on the threaded bolt (6) – if fitted – and retighten the nut (4).
4. Check the O-ring (7) – replace if damaged.
5. Screw the cap (3) on the high pressure filter and tighten it with the pin spanner (2b) or the open-end wrench (2a).

6.5.3 Filter elements for high pressure filters

Insert the filter element suitable for the spraying material and the spraying nozzle into the high pressure filter. The mesh size should always be slightly finer than the bore of the nozzle used.

Filter element	Nozzle size		WIWA order number	
			Type 01 / type 05	Type 11 / type 13
M 200 (white)		up to 0.23 mm/.009"	0160636	0162744
M 150 (red)	over 0.23 mm/.009"	up to 0.33 mm/.013"	0160628	0162752
M 100 (black)	over 0.33 mm/.013"	up to 0.38 mm/.015"	0160059	0162760

Filter element	Nozzle size		WIWA order number	
			Type 01 / type 05	Type 11 / type 13
M 70 (yellow)	over 0.38 mm/.015"	up to 0.66 mm/.026"	0160601	0162779
M 50 (orange)	over 0.66 mm/.026"		0163023	0162787
M 30 (blue)			0463779	0467782
M 20 (green)				0646628



Do not use a filter element when applying coarsely pigmented or fibre filled materials. The standard suction strainer should remain in the filter housing or be replaced by a wider mesh screen. In the case of a material change, you must clean or replace both the filter element in the high pressure filter and the material screen in the suction system if necessary.

6.6 Recommended operating materials

Only use original operating materials from WIWA:

Operating materials	WIWA order number
Release agent, yellow (0.5 l) ¹ (standard)	0163333
Release agent, red (0.5 l) ¹ (especially for isocyanate)	0640651
Anti-freeze agent (0.5 l) ²	0631387
Pneumatic oil (0.5 l) ²	0632579

¹ Plasticizer to fill into the release agent cups of the main pump and the feed pumps

² for maintenance unit

Materials required for cleaning and repair work (see information in spare parts lists)

The release agent and the pneumatic oil are available in large containers on request.

6.7 Special tools

The following special tools for maintenance and repair work are included with delivery:

- ▶ pin spanner for opening the high pressure filter



Fig. 52: Pin spanner for high pressure filter

7 Rectification of faults

Fault	Possible cause	Remedy
Pressure release not possible (compressed air shut-off valve closed)	<ol style="list-style-type: none"> 1. Drain hose or ball valve clogged. 2. High pressure filter clogged. 	<ul style="list-style-type: none"> ➤ Carefully open the device, cover screw fittings with a rag ➤ Remove hardened material with solvent if possible, if necessary soak parts in solvent or remove with other mechanical means or replace ➤ Contact WIWA service if necessary
Pump does not start, despite operation of spray gun or opened relief valve (on high pressure filter).	<ol style="list-style-type: none"> 1. Compressed air shut-off valve closed. 2. High pressure filter clogged. 3. Drain hose or ball valve clogged. 4. Air motor defective. 	<ul style="list-style-type: none"> ➤ Open the compressed air shut-off valve. ➤ Clean or renew the filter element. ➤ Clean drain hose or ball valve, replace if required. ➤ Repair air motor – contact WIWA service if necessary
Pump runs but no spraying material is transported to the nozzle.	<ol style="list-style-type: none"> 1. Suction strainer clogged. 2. Suction hose clogged. 3. Ball of bottom valve does not lift off (stuck). 4. The bottom valve does not close. 	<ul style="list-style-type: none"> ➤ Clean strainer and replace if necessary ➤ Replace the hose. ➤ Open the spray gun without nozzle. ➤ Open the relief ball valve on the high pressure filter. ➤ Slightly knock the bottom valve from the side (hammer). ➤ Unscrew the suction system and loosen the ball of the bottom valve from below with a pin or a screwdriver. ➤ Unscrew the bottom valve, thoroughly clean ball and seat.
The pump delivers material but does not stop when the spray gun is closed.	<ol style="list-style-type: none"> 1. Packing or valve worn. 	<ul style="list-style-type: none"> ➤ Replace parts.
The pump runs uniformly, but the required spraying pressure is not reached.	<ol style="list-style-type: none"> 1. The air pressure is too low or there is not enough air. 2. Spraying nozzle (new) too big. 3. Spraying nozzle (worn) too big. 4. Air motor iced (runs too slowly). 	<ul style="list-style-type: none"> ➤ Increase the air pressure on the pneumatic regulator or check the air line for correct cross-section. ➤ Install a smaller nozzle or use a bigger pump. ➤ Install a new nozzle. ➤ If possible reduce the air inlet pressure. ➤ Install a maintenance unit with oiler if one is not yet present. Fill the oiler with anti-freeze agent (ethylene glycol) and adjust as instructed in the operation manual: Reference value 1 drop per approx. 10 double-strokes.

Fault	Possible cause	Remedy
The pump runs irregularly (can be noticed by differences in up and down stroke speeds) and does not reach the required pressure.	1. The viscosity of the spraying material is too high (suction losses).	<ul style="list-style-type: none"> ➤ Dilute the spraying material. ➤ Use a bigger pump.
	2. Suction system leaking (fluctuations in spray jet).	<ul style="list-style-type: none"> ➤ Check the packings on all screw fittings of the suction pipe or the suction hose, replace if necessary (see spare parts list for suction system or direction suction).
	3. Bottom valve leaking (pump only stops in upward stroke when the spray gun is closed).	<ul style="list-style-type: none"> ➤ Unscrew the bottom valve, thoroughly clean ball and seat, if necessary replace ball or valve seat.
	4. Piston valve leaking (pump only stops in downward stroke when the spray gun is closed).	<ul style="list-style-type: none"> ➤ Clean ball and valve in the dual piston, replace ball and/or valve seat as necessary.
	5. Bottom or top packing leaking (wear)	<ul style="list-style-type: none"> ➤ Replace the packing.
Material escapes from the overflow on the air motor.	1. Packing worn.	<ul style="list-style-type: none"> ➤ Replace the packing. ➤ Do not close off the overflow!

8 Technical data

8.1 PROFIT series

Model	3010	3022	3033	4210	4222	4233
Max. free-flow output (l/min)	3.0	3.0	3.0	4.2	4.2	4.2
Pressure ratio	10 : 1	22 : 1	33 : 1	10 : 1	22 : 1	33 : 1
Pump capacity per double stroke (cm ³)	14	14	14	27	27	27
Max. air inlet pressure (bar)	8	8	8	8	8	8
Max. permissible operating pressure (bar)	80	176	264	80	176	264
Piston diameter of the air motor (mm)	50	70	85	50	70	85
Piston stroke of the air motor (mm)	42	42	42	75	75	75
Air consumption (l/min) (per doubles stroke at 1 bar air inlet pressure) ¹	0.21	0.41	0.60	0.34	0.66	0.98
Air inlet (maintenance unit)						
Material outlet (high pressure filter)						
Emitted sound pressure level at the work place was determined in accordance with the DIN EN ISO 3744, DIN EN 31200, DIN EN 31201 and DIN 45635-20 standards						
Sound pressure level at 15 DH with 8 bar L _p	84 dB (A)					
Sound power level L _w	95 dB (A)					

8.2 PHOENIX series

Model	6530	6552	11010	11018	11032
Max. free-flow output (l/min)	6.5	6.5	11	11	11
Pressure ratio	30:1	52:1	10:1	18:1	32:1
Pump capacity per double stroke (cm ³)	40	40	72	72	72
Max. air inlet pressure (bar)	8	8	8	8	8
Max. permissible operating pressure (bar)	240	416	144	144	256
Piston diameter of the air motor (mm)	105	140	85	105	140
Piston stroke of the air motor (mm)	75	75	75	75	75
Air consumption (l/min) (per doubles stroke at 1 bar air inlet pressure) ¹					
Air inlet (maintenance unit)	G1/4"	G3/8"	G1/4"	G1/4"	G3/8"
Material outlet (high pressure filter)	1/4 NPSM 1/4 NPT (hot spraying)	1/4 NPT	1/4 NPT	1/4 NPT	1/4 NPT
Emitted sound pressure level at the work place was determined in accordance with the DIN EN ISO 3744, DIN EN 31200, DIN EN 31201 and DIN 45635-20 standards					
Sound pressure level at 15 DH with 8 bar L _p	84 dB (A)				
Sound power level L _w	95 dB (A)				

8.3 SUPER series

Model	10066	15042
Max. free-flow output (l/min)	10	15
Pressure ratio	66 : 1	42 : 1
Pump capacity per double stroke (cm ³)	72	106
Max. air inlet pressure (bar)	6.5	8
Max. permissible operating pressure (bar)	429	336
Piston diameter of the air motor (mm)	200	200
Piston stroke of the air motor (mm)	75	75
Air consumption (l/min) (per doubles stroke at 1 bar air inlet pressure) ¹		
Air inlet (maintenance unit)	3/4"	3/4"
Material outlet (high pressure filter)	1/4" NPS(A) (2× 3/8")	1/4" NPS(A) (2× 3/8")

Emitted sound pressure level at the work place

was determined in accordance with the DIN EN ISO 3744, DIN EN 31200, DIN EN 31201 and DIN 45635-20 standards

Sound pressure level at 15 DH with 8 bar L_p 84 dB (A)

Sound power level L_w 95 dB (A)

8.4 PROFESSIONAL series

Type	24026	24053	24071	28023	28048	28064	38032	38042	44024	44032
Max. free-flow output (l/min)	24	24	24	28	28	28	38	38	44	44
Pressure ratio	26:1	53:1	71:1	23:1	48:1	64:1	32:1	42:1	24:1	32:1
Pump capacity per double stroke (cm ³)	138	138	138	153	153	153	235	235	306	306
Max. air inlet pressure (bar)	8	8	6.5	8	8	7	8	8	8	8
Max. permitted operating pressure (bar)	208	420	460	184	380	450	255	335	190	255
Piston diameter of the air motor (mm)	140	200	230	140	200	230	200	230	200	230
Piston stroke of the air motor (mm)	120	120	120	120	120	120	120	120	120	120
Air consumption (l/min) (per doubles stroke at 1 bar air inlet pressure) ¹										
Material outlet (high pressure filter)	1/4 NPSM (A) 2 × 3/8"									
Air inlet (maintenance unit)	1"									

Emitted sound pressure level at the work place

was determined in accordance with the DIN EN ISO 3744, DIN EN 31200, DIN EN 31201 and DIN 45635-20 standards

Sound pressure level at 15 DH with 8 bar L_p 84 dB (A)

Sound power level L_w 95 dB (A)

8.5 HERKULES series

Model	35061	35075	48046	48057	60028	60036
Max. free-flow output (l/min)	35	35	48	48	60	60
Pressure ratio	61:1	75:1	46:1	57:1	28:1	36:1
Pump capacity per double stroke (cm ³)	275	275	360	360	550	550
Max. air inlet pressure (bar)	7	6	8	7	8	8
Max. permitted operating pressure (bar)	427	420	368	399	224	288
Piston diameter of the air motor (mm)	300	333	300	333	300	333
Piston stroke of the air motor (mm)	120	120	120	120	120	120
Air consumption (l/min) (per doubles stroke at 1 bar air inlet pressure) ¹						
Material outlet (high pressure filter)	1/4 NPSM (A) (2x3/8")					
Air inlet (maintenance unit)	1"					
Emitted sound pressure level at the work place was determined in accordance with the DIN EN ISO 3744, DIN EN 31200, DIN EN 31201 and DIN 45635-20 standards						
Sound pressure level at 15 DH with 8 bar L _p	84 dB (A)					
Sound power level L _w	95 dB (A)					

8.6 Unit card

The unit card contains all important and safety relevant data and information about the unit.

- Exact designation and manufacturer data,
- technical data and limit values,
- equipment and test certificate,
- purchasing data,
- unit identification (machine components and supplied accessories with item numbers and spare part numbers).
- list of supplied documentation

8.7 Type plate

The type plate is located on the cylinder of the material pump. It contains the most important technical data for the high pressure pump.

WIWA - D-35633 Lahnau		CE	
II 2G cT4			
Druckluftbetriebene Kolbenpumpe/Air operated piston pump			
Geräte-Type/Unit	106.42		
FM. p. DH/Output p. cycle	106	cm ³	3.58 l1/02
Übers.-Verhältnis/Ratio	42	:	1
Max. Lufteingang/Air	8	bar	416 PSI
Max. Betriebsdruck/Fluid	336	bar	4872 PSI
Max. Temperatur	80	°C	176 °F
Serial-no. - Model year	610 - 20...		

Fig. 53: Type plate



Please check that the data on the type plate is identical to the specifications on the unit card. Please notify us immediately in case of discrepancies or if the type plate is missing.

Additionally, attachment devices (if fitted) have a separate type plate, such as:

- Agitator
- Material heater

These type plates contain the technical data and serial numbers of the corresponding devices.



because it works

WIWA Service +49 (0)6441 609 140

Headquarters and production

WIWA Wilhelm Wagner GmbH & Co. KG

Gewerbestr. 1-3
35633 Lahnu, Germany
Phone: +49 6441 609-0
Fax: +49 6441 609-50
E-Mail: info@wiwa.de
Homepage: www.wiwa.de

WIWA Partnership USA

WIWA LP

107 N. Main St.
P.O. Box 398, Alger, OH 45812
Phone: +1 (419) 757-0141
Fax: +1 (419) 549-5173
Toll Free: +1(855) 757-0141
E-Mail: jwold@wiwalp.com
Homepage: www.wiwalp.com

WIWA Subsidiary China

WIWA (Taicang) Co., Ltd.

Building A of Huaxin Industrial Park
No.11 East Qingdao Road, Taicang City
Jiangsu Province 215400, P.R.China
Phone: +86 512-5354 8857
Fax: +86 512-5354 8859
E-Mail: info@wiwa-china.com
Homepage: www.wiwa-china.com

WIWA Middle East General Trading LLC

Mohd Farhan Khan
Jebel Ali Industrial 1, Dubai, UAE
Phone: +9714 884 8220
E-Mail: middleeast@wiwa.com

WWW.WIWA.DE