



KRAMER ELECTRONICS LTD.

USER MANUAL

MODEL:

F-121

XGA/Audio Line Transmitter
Mounting Box for Ackermann
Floor Boxes

P/N: 2900-000715 Rev 2

Contents

1	Introduction	1
2	Getting Started	2
2.1	Achieving the Best Performance	2
2.2	Safety Instructions	2
2.3	Recycling Kramer Products	3
3	Overview	4
3.1	Defining the F-121 Description	4
3.2	About the Power Connect™ Feature	7
3.3	Shielded Twisted Pair (STP) / Unshielded Twisted Pair (UTP)	7
3.4	DDC Support	7
4	Connecting the F-121	8
4.1	Installing a Kramer Insert	8
4.2	Connecting the Cables to the Rear Side of the F-121	8
4.3	Installing the F-121 inside the Ackermann Floor Box	9
4.4	Connecting the Front Panel Ports	10
4.5	Wiring the 8-pin Terminal Block Line Output Connector	10
4.6	Wiring the TP LINE IN / LINE OUT RJ-45 Connectors	11
5	Technical Specifications	12

Figures

Figure 1: The F-121 XGA / Audio Line Driver Mounting Box	5
Figure 2: F-121 Fitted in an Ackermann Floor Box	5
Figure 1: F-121 XGA Line Transmitter Mounting Box	6
Figure 2: Installing the F-121 XGA / Audio Line Transmitter Mounting Box	9
Figure 3: Terminal Block Pinouts	10
Figure 4: TP PINOUT	11

1 Introduction

Welcome to Kramer Electronics! Since 1981, Kramer Electronics has been providing a world of unique, creative, and affordable solutions to the vast range of problems that confront video, audio, presentation, and broadcasting professionals on a daily basis. In recent years, we have redesigned and upgraded most of our line, making the best even better!

Our 1,000-plus different models now appear in 11 groups that are clearly defined by function: GROUP 1: Distribution Amplifiers; GROUP 2: Switchers and Routers; GROUP 3: Control Systems; GROUP 4: Format/Standards Converters; GROUP 5: Range Extenders and Repeaters; GROUP 6: Specialty AV Products; GROUP 7: Scan Converters and Scalers; GROUP 8: Cables and Connectors; GROUP 9: Room Connectivity; GROUP 10: Accessories and Rack Adapters and GROUP 11: Sierra Products.

Congratulations on purchasing your Kramer **F-121 XGA / Audio Line Transmitter Mounting Box**, which is ideal for the following typical applications:

- Presentation venues
- Multimedia applications
- Long-range graphics distribution for schools, hospitals, security, and stores

2 Getting Started

We recommend that you:

- Unpack the equipment carefully and save the original box and packaging materials for possible future shipment
- Review the contents of this user manual
- Use Kramer high-performance, high-resolution cables



Go to <http://www.kramerelectronics.com> to check for up-to-date user manuals, application programs, and to check if firmware upgrades are available (where appropriate).

2.1 Achieving the Best Performance

To achieve the best performance:

- Use only good quality connection cables to avoid interference, deterioration in signal quality due to poor matching, and elevated noise levels (often associated with low quality cables)
- Do not secure the cables in tight bundles or roll the slack into tight coils
- Avoid interference from neighboring electrical appliances that may adversely influence signal quality
- Position your Kramer **product** away from moisture, excessive sunlight and dust

2.2 Safety Instructions



Caution: There are no operator serviceable parts inside the unit

Warning: Use only the Kramer Electronics input power wall adapter that is provided with the unit

Warning: Disconnect the power and unplug the unit from the wall before installing



This equipment is to be used only inside a building. It may only be connected to other equipment that is installed inside a building.

2.3 Recycling Kramer Products

The Waste Electrical and Electronic Equipment (WEEE) Directive 2002/96/EC aims to reduce the amount of WEEE sent for disposal to landfill or incineration by requiring it to be collected and recycled. To comply with the WEEE Directive, Kramer Electronics has made arrangements with the European Advanced Recycling Network (EARN) and will cover any costs of treatment, recycling and recovery of waste Kramer Electronics branded equipment on arrival at the EARN facility. For details of Kramer's recycling arrangements in your particular country go to our recycling pages at <http://www.kramerelectronics.com/support/recycling/>.

3 Overview

The **F-121** mounting box for Ackermann floor boxes is a twisted pair transmitter for computer graphics video signals up to and exceeding UXGA and unbalanced stereo audio. It converts the input signals into a twisted pair signal that it transmits to a compatible twisted pair receiver (for example, the Kramer **TP-122**). The **F-121** includes two adjacent openings that lets you fit two single inserts or one dual insert into the device.

In particular, the **F-121** transmitter features:

- A transmission range of more than 300ft (more than 100m), and a 20kHz audio bandwidth with an S/N ratio that exceeds 80dB on the same transmission range
- The capability to store EDID when programmed by the Kramer **FC-200 XGA EDID Copier**
The EDID of the display on the transmitter can be captured via the FC-200.
- Resolutions of up to UXGA
- The Kramer Power Connect™ feature
- A 12V DC power supply

3.1 Defining the F-121 Description

This section defines the **F-121**.

[Figure 1](#) shows the **F-121 XGA / Audio Line Transmitter Mounting Box**:



Figure 1: The F-121 XGA / Audio Line Driver Mounting Box

[Figure 2](#) shows the F-121 fitted in an Ackermann floor box:



Figure 2: F-121 Fitted in an Ackermann Floor Box

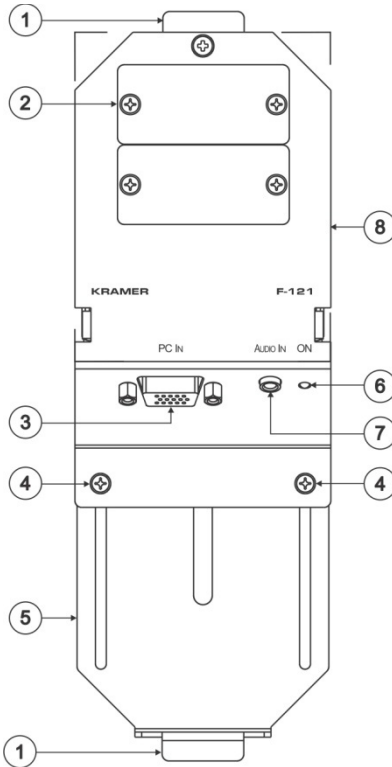

Figure 3: F-121 XGA Line Transmitter Mounting Box

#	Feature	Function
1	Mounting Tabs	For fitting the F-121 into an Ackermann floor box
2	Blank Inserts (2)	Replace with Kramer wall plate inserts (see Section 4.1)
3	PC IN 15-pin HD F Connector	Connect to the XGA source
4	Slide Screws (2)	Release to increase or decrease the length of the unit; tighten to fix size
5	Adjustable Mounting Slide	For adjusting the size of the unit to fit an Ackermann floor box
6	ON LED	Lights red when receiving power, lights green when receiving a signal from a video source
7	AUDIO IN 3.5mm mini Connector	Connect to an unbalanced stereo audio source
8	8-pin Terminal Block Line Output Connector	Connect to the line in connector on the receiver (see Section 4.5) (located inside the mounting box)

3.2 About the Power Connect™ Feature

The Power Connect feature applies as long as the cable can carry power. This feature is available when using STP cable and the distance does not exceed 50m (164ft) on standard CAT 5 cable. For longer distances, heavier gauge cable should be used (TP cable is still suitable for the video/audio transmission, but not for feeding the power at these distances). For units which are connected via RJ-45 connectors, make sure that the shield of the STP cable is connected to the metal casing of the connectors on both ends of the cable. For units which are connected via terminal block connectors, the shield of the STP cable must be connected to a ground terminal on the units at both ends (use the ground terminal of the power supply connection if necessary).

For a TP cable exceeding a distance of 50m, separate power supplies should be connected to the transmitter and to the receiver simultaneously.

3.3 Shielded Twisted Pair (STP) / Unshielded Twisted Pair (UTP)

We recommend that you use Shielded Twisted Pair (STP) cable, and stress that the compliance to electromagnetic interference was tested using STP cable. There are different levels of STP cable available, and we advise you to use the best quality STP cable that you can afford. Our non-skew-free cable, Kramer **BC-STP** is intended for analog signals where skewing is not an issue.

In cases where there is skewing, our Unshielded Twisted Pair (UTP) skew-free cable, Kramer **BC-XTP**, may be advantageous, and UTP cable might also be preferable for long range applications. In any event when using UTP cable, it is advisable to ensure that the cable is installed far away from electric cables, motors and so on, which are prone to create electrical interference.

3.4 DDC Support

When establishing a VGA connection between a PC or laptop and a display device, a set of parameters known as EDID is exchanged between them, which is carried over the DDC channel. In some PC graphic cards and laptops, this information exchange is essential for proper VGA OUT operation.

4 Connecting the F-121



Always switch off the power to each device before connecting it to your **F-121**. After connecting your **F-121**, connect its power and then switch on the power to each device.

To install the **F-121** you have to install the inserts and the transmitter which is connected via TP to a receiver.

To install the **F-121**, do the following:

- Install the Kramer inserts (see [Section 4.1](#))
- Connect the cables to the rear side (see [Section 4.2](#))
- Install the **F-121** inside the Ackermann floor box (see [Section 4.3](#))
- Connect the front panel ports (see [Section 4.4](#))
- Connect the twisted pair cable to the receiver (for example, the Kramer **TP-122**)

4.1 Installing a Kramer Insert

To install a Kramer insert, do the following:

1. Unscrew the two screws holding the blank insert and remove it.
2. Place and align the required wall plate insert item over the opening.
3. Insert the two screws to fix the insert in place, and tighten them.

4.2 Connecting the Cables to the Rear Side of the F-121

To connect the rear side cables, do the following:

1. Run the cables through the Ackermann under-floor cable opening.
2. Connect the cables to the rear side of the inserts.
3. Connect the cables to the rear side of the **F-121** transmitter, that is, attach the:

- Terminal block line output of the **F-121** to the pre-installed UTP wiring that connects to the TP receiver (for example, the Kramer TP-122 XGA / Audio Line Receiver) with a range of more than 300ft (>100m), see [Section 4.5](#)
- 12V DC power supply to the power terminal blocks (connect the wire labeled “+” to the +12V pin, and the wire labeled “-” to the GND pin) taking care that the polarity is correct (see [Figure 5](#))

4.3 Installing the F-121 inside the Ackermann Floor Box

To install the **F-121** inside the Ackermann floor box, as illustrated in [Figure 4](#), perform the following steps:

1. Slightly release the two slide screws (do not remove them) to let the adjustable mounting slide move freely.
2. Fit the **F-121** mounting box into its designated place inside the Ackermann floor box (see [Figure 2](#)).
3. Insert the fixed tab into the slot in the Ackermann box.
4. Adjust the size of the unit to fit the space in the box.
5. Insert the tab on the adjustable mounting box to the appropriate slot in the Ackermann box.
6. Tighten slide screws to fix the size of the unit.

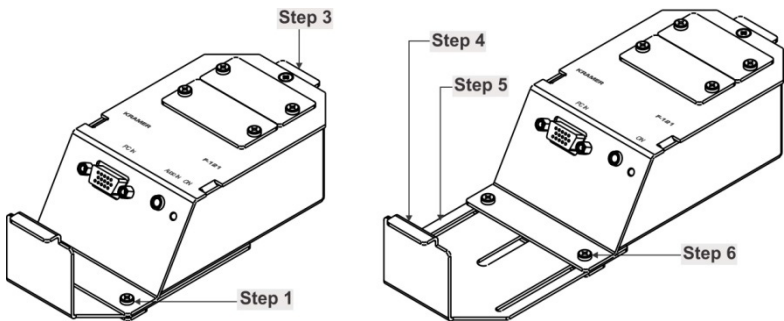

Figure 4: Installing the F-121 XGA / Audio Line Transmitter Mounting Box

4.4 Connecting the Front Panel Ports

To connect the front panel ports:

1. On the **F-121** transmitter section, connect:
 - The XGA source (for example, a laptop's graphics card) to the PC IN 15-pin HD (F) connector
 - An audio source to the AUDIO IN 3.5mm mini jack, for example, using a Kramer C-GMA/GMA cable (VGA 15-pin HD (M) +Audio jack to VGA 15-pin HD (M) +Audio jack)
Alternatively, you can connect an XGA source to the XGA INPUT 15-pin HD (F) connector, and a separate audio source to the AUDIO IN 3.5mm mini jack
2. Connect the appropriate connectors to the inserts.

4.5 Wiring the 8-pin Terminal Block Line Output Connector

The 8-pin terminal block is an easy plug-in connector for attaching the UTP cable. Follow the colors of the color-coded sticker on these terminals for proper connection of the UTP cable. [Figure 5](#) defines the pinouts for the terminal block.

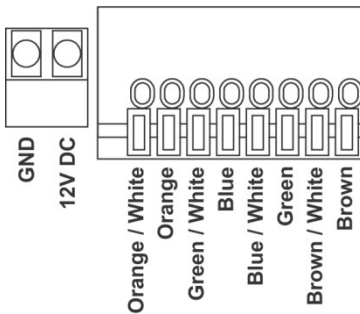

Figure 5: Terminal Block Pinouts

Notes:

- Use the connector clips only when removing wires, not when inserting them
- Each wire should protrude 9mm (0.35in) from the plastic insulation so that it can be easily connected. To prevent the wires crossing, be sure that each wire is fully inserted

4.6 Wiring the TP LINE IN / LINE OUT RJ-45 Connectors

This section defines the TP pinout, using a **straight** pin-to-pin cable with RJ-45 connectors.

EIA /TIA 568B	
PIN	Wire Color
1	Orange / White
2	Orange
3	Green / White
4	Blue
5	Blue / White
6	Green
7	Brown / White
8	Brown

Figure 6: TP PINOUT

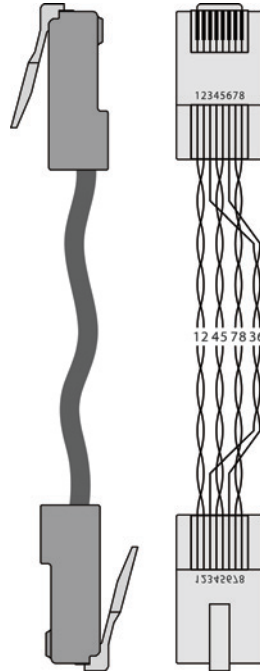

5 Technical Specifications

INPUTS:	1 UXGA on a 15-pin HD (F) connector 1 Unbalanced stereo audio on a 3.5mm mini connector 1 Power 12V DC on 2-pin terminal block
OUTPUTS:	1 UTP on an 8-pin terminal block with springs
MAX. OUTPUT LEVEL:	Video: 1.9Vpp Audio: 2.7Vpp
RESOLUTION:	Up to UXGA
AUDIO BANDWIDTH:	20kHz
DIFF. GAIN:	5.8%
DIFF. PHASE:	0.5 Deg
K-FACTOR:	<0.05%
S/N RATIO:	Video: 60dB @5MHz Audio: 78dB @ 1KHz
CONTROLS:	Video detection LED
COUPLING:	Video: AC Audio: AC
AUDIO THD + NOISE:	0.04%
AUDIO 2nd HARMONIC:	0.001%
POWER SOURCE:	12V DC 390mA (feeding TP-122-od receiver); self current 110mA
OPERATING TEMPERATURE:	0° to +40°C (32° to 104°F)
STORAGE TEMPERATURE:	-40° to +70°C (-40° to 158°F)
HUMIDITY:	10% to 90%, RHL non-condensing
DIMENSIONS:	Closed: 7.5cm x 15.7cm x 4.4cm (2.95" x 6.18" x 1.73") W, D, H Open: 7.5cm x 15.7cm x 4.4cm (2.95" x 6.18" x 1.73") W, D, H
WEIGHT:	0.19kg (0.42lbs) approx.
ACCESSORIES:	Power supply
Specifications are subject to change without notice at http://www.kramerelectronics.com	

LIMITED WARRANTY

The warranty obligations of Kramer Electronics for this product are limited to the terms set forth below:

What is Covered

This limited warranty covers defects in materials and workmanship in this product.

What is Not Covered

This limited warranty does not cover any damage, deterioration or malfunction resulting from any alteration, modification, improper or unreasonable use or maintenance, misuse, abuse, accident, neglect, exposure to excess moisture, fire, improper packing and shipping (such claims must be presented to the carrier), lightning, power surges, or other acts of nature. This limited warranty does not cover any damage, deterioration or malfunction resulting from the installation or removal of this product from any installation, any unauthorized tampering with this product, any repairs attempted by anyone unauthorized by Kramer Electronics to make such repairs, or any other cause which does not relate directly to a defect in materials and/or workmanship of this product. This limited warranty does not cover cartons, equipment enclosures, cables or accessories used in conjunction with this product.

Without limiting any other exclusion herein, Kramer Electronics does not warrant that the product covered hereby, including, without limitation, the technology and/or integrated circuit(s) included in the product, will not become obsolete or that such items are or will remain compatible with any other product or technology with which the product may be used.

How Long Does this Coverage Last

Seven years as of this printing; please check our Web site for the most current and accurate warranty information.

Who is Covered

Only the original purchaser of this product is covered under this limited warranty. This limited warranty is not transferable to subsequent purchasers or owners of this product.

What Kramer Electronics will do

Kramer Electronics will, at its sole option, provide one of the following three remedies to whatever extent it shall deem necessary to satisfy a proper claim under this limited warranty:

1. Elect to repair or facilitate the repair of any defective parts within a reasonable period of time, free of any charge for the necessary parts and labor to complete the repair and restore this product to its proper operating condition. Kramer Electronics will also pay the shipping costs necessary to return this product once the repair is complete.
2. Replace this product with a direct replacement or with a similar product deemed by Kramer Electronics to perform substantially the same function as the original product.
3. Issue a refund of the original purchase price less depreciation to be determined based on the age of the product at the time remedy is sought under this limited warranty.

What Kramer Electronics will not do Under This Limited Warranty

If this product is returned to Kramer Electronics or the authorized dealer from which it was purchased or any other party authorized to repair Kramer Electronics products, this product must be insured during shipment, with the insurance and shipping charges prepaid by you. If this product is returned uninsured, you assume all risks of loss or damage during shipment. Kramer Electronics will not be responsible for any costs related to the removal or re-installation of this product from or into any installation. Kramer Electronics will not be responsible for any costs related to any setting up this product, any adjustment of user controls or any programming required for a specific installation of this product.

How to Obtain a Remedy under this Limited Warranty

To obtain a remedy under this limited warranty, you must contact either the authorized Kramer Electronics reseller from whom you purchased this product or the Kramer Electronics office nearest you. For a list of authorized Kramer Electronics resellers and/or Kramer Electronics authorized service providers, please visit our web site at www.kramerelectronics.com or contact the Kramer Electronics office nearest you.

In order to pursue any remedy under this limited warranty, you must possess an original, dated receipt as proof of purchase from an authorized Kramer Electronics reseller. If this product is returned under this limited warranty, a return authorization number, obtained from Kramer Electronics, will be required. You may also be directed to an authorized reseller or a person authorized by Kramer Electronics to repair the product.

If it is decided that this product should be returned directly to Kramer Electronics, this product should be properly packed, preferably in the original carton, for shipping. Cartons not bearing a return authorization number will be refused.

Limitation on Liability

THE MAXIMUM LIABILITY OF KRAMER ELECTRONICS UNDER THIS LIMITED WARRANTY SHALL NOT EXCEED THE ACTUAL PURCHASE PRICE PAID FOR THE PRODUCT. TO THE MAXIMUM EXTENT PERMITTED BY LAW, KRAMER ELECTRONICS IS NOT RESPONSIBLE FOR DIRECT, SPECIAL, INCIDENTAL OR CONSEQUENTIAL DAMAGES RESULTING FROM ANY BREACH OF WARRANTY OR CONDITION, OR UNDER ANY OTHER LEGAL THEORY. Some countries, districts or states do not allow the exclusion or limitation of relief, special, incidental, consequential or indirect damages, or the limitation of liability to specified amounts, so the above limitations or exclusions may not apply to you.

Exclusive Remedy

TO THE MAXIMUM EXTENT PERMITTED BY LAW, THIS LIMITED WARRANTY AND THE REMEDIES SET FORTH ABOVE ARE EXCLUSIVE AND IN LIEU OF ALL OTHER WARRANTIES, REMEDIES AND CONDITIONS, WHETHER ORAL OR WRITTEN, EXPRESS OR IMPLIED. TO THE MAXIMUM EXTENT PERMITTED BY LAW, KRAMER ELECTRONICS SPECIFICALLY DISCLAIMS ANY AND ALL IMPLIED WARRANTIES, INCLUDING, WITHOUT LIMITATION, WARRANTIES OF MERCHANTABILITY AND FITNESS FOR A PARTICULAR PURPOSE. IF KRAMER ELECTRONICS CANNOT LAWFULLY DISCLAIM OR EXCLUDE IMPLIED WARRANTIES UNDER APPLICABLE LAW, THEN ALL IMPLIED WARRANTIES COVERING THIS PRODUCT, INCLUDING WARRANTIES OF MERCHANTABILITY AND FITNESS FOR A PARTICULAR PURPOSE, SHALL APPLY TO THIS PRODUCT AS PROVIDED UNDER APPLICABLE LAW.

IF ANY PRODUCT TO WHICH THIS LIMITED WARRANTY APPLIES IS A "CONSUMER PRODUCT" UNDER THE MAGNUSON-MOSS WARRANTY ACT (15 U.S.C.A. §2301, ET SEQ.) OR OTHER APPLICABLE LAW, THE FOREGOING DISCLAIMER OF IMPLIED WARRANTIES SHALL NOT APPLY TO YOU, AND ALL IMPLIED WARRANTIES ON THIS PRODUCT, INCLUDING WARRANTIES OF MERCHANTABILITY AND FITNESS FOR THE PARTICULAR PURPOSE, SHALL APPLY AS PROVIDED UNDER APPLICABLE LAW.

Other Conditions

This limited warranty gives you specific legal rights, and you may have other rights which vary from country to country or state to state.

This limited warranty is void if (i) the label bearing the serial number of this product has been removed or defaced, (ii) the product is not distributed by Kramer Electronics or (iii) this product is not purchased from an authorized Kramer Electronics reseller. If you are unsure whether a reseller is an authorized Kramer Electronics reseller, please visit our Web site at www.kramerelectronics.com or contact a Kramer Electronics office from the list at the end of this document.

Your rights under this limited warranty are not diminished if you do not complete and return the product registration form or complete and submit the online product registration form. Kramer Electronics thanks you for purchasing a Kramer Electronics product. We hope it will give you years of satisfaction.



For the latest information on our products and a list of Kramer distributors, visit our Web site where updates to this user manual may be found.

We welcome your questions, comments, and feedback.

Web site: www.kramerelectronics.com

E-mail: info@kramerel.com



SAFETY WARNING

Disconnect the unit from the power supply before opening and servicing

P/N: 2900-000715



Rev: 2

