

Cuisinart®

INSTRUCTION
BOOKLET



12-Cup Programmable Thermal Coffeemaker

DTC-975 Series

For your safety and continued enjoyment of this product, always read the instruction book carefully before using.

IMPORTANT SAFEGUARDS

When using electrical appliances, basic safety precautions should always be followed to reduce the risk of fire, electric shock and/or injury to persons, including the following:

1. Read all instructions before operating or using the appliance.
2. Do not touch hot surfaces. Use handles and knobs.
3. To protect against electrical shock, do not place cord, plugs or appliance in water or other liquid.
4. Close supervision is necessary when any appliance is used by or near children.
5. Unplug from outlet when not in use and before cleaning. Allow to cool before putting on or taking off parts and before cleaning the appliance.
6. Do not operate any appliance with damaged cord or plug, or after the appliance malfunctions or has been damaged in any manner. Return appliance to authorized service facility for examination, repair or adjustment.
7. The use of an accessory not evaluated for use with the appliance may cause injuries.
8. Do not use outdoors.
9. Do not let cord hang over edge of table or counter, or touch hot surface.
10. Do not place on or near a hot gas or electric burner or in a heated oven.
11. Do not move entire unit when appliance is on or when thermal carafe contains hot liquids.
12. Prior to connecting or disconnecting plug from wall outlet, turn all controls to "OFF".
13. Do not use appliance for other than intended purpose. Appliance is for household use only.
14. **WARNING:** To reduce risk of fire or electrical shock, do not remove bottom cover. No user-serviceable parts are inside. Repair should be done by authorized personnel only.

15. Special instructions for the thermal carafe:

- A. The thermal carafe is designed for use with this appliance only. It must never be used with any other drip-type coffeemaker, or on a range top or in a microwave oven.
- B. Do not set a hot thermal carafe on a wet or cold surface. Do not put thermal carafe in water. Do not place on hot surface.
- C. Do not use a cracked thermal carafe or a thermal carafe that has a loose or weakened handle.
- D. Do not clean thermal carafe with cleaners, steel wool pads or abrasive material. Do not place sharp or hard objects in the thermal carafe.

16. Do not place a cloth or otherwise restrict airflow beneath coffeemaker.

SAVE THESE INSTRUCTIONS

HOUSEHOLD USE ONLY

This appliance has a polarized plug (one blade is wider than the other). To reduce the risk of electric shock, this plug is intended to fit into a polarized outlet only one way. If the plug does not fit fully into the outlet, reverse the plug. If it still does not fit, contact a qualified electrician. Do not attempt to modify the plug in any way.

SPECIAL CORD SET INSTRUCTIONS

A short power-supply cord is provided to reduce the risk of becoming entangled in or tripping over a longer cord. Extension cords are available and may be used if care is exercised in their use. If an extension cord is used, the marked electrical rating of the extension cord should be at least as great as the electrical rating of the appliance, and the cord should be arranged so it will not drape over the countertop or tabletop where it can be tripped over or pulled on by children.



IMPORTANT UNPACKING INSTRUCTIONS

Place the box on a large, sturdy, flat surface. Lay the box on its side. Slide the packaged unit out of the box. Remove the foam insert and the cardboard insert. Now remove the carafe from the coffeemaker. Remove the carafe from its cardboard packaging. Carefully lift the coffeemaker from the remaining inserts. Remove the plastic bag from the coffeemaker. We suggest you save all packing materials in the event that future shipping of the machine is needed. Keep all plastic bags away from children.

TABLE OF CONTENTS

Important Safeguards	Page 1
Unpacking Instructions	Page 2
Introduction	Page 2
Using the Programming Feature	Page 2
Making Coffee	Page 3
Cleaning and Maintenance	Page 4
Features and Benefits	Page 5
Warranty	Page 6

INTRODUCTION

The Cuisinart® Thermal Carafe Coffeemaker is a coffee lover's dream. It delivers the freshest coffee in the world. The secret? The patented lid. Coffee brews and pours through and you never have to open or turn the lid. Flavor and heat are sealed in. Now, you can program your coffeemaker to start brewing when you want. Simply set the desired brew time, fill the reservoir with water, put in your filter, add ground coffee and press the "ON" button. In minutes, you'll have a wonderfully fresh pot of coffee.

We know the Cuisinart® Thermal Carafe Coffeemaker will bring you years of pleasure. Nothing is more satisfying than a rich cup of your favorite brew.

PREPARATION FOR USE

Before first use, clean the thermal carafe coffeemaker by completing a brew cycle as described below, without using coffee or coffee filter.

USING THE PROGRAMMING FEATURE

To Set The Clock

To set the time, press and hold the hour or minute button for two seconds. "Time set" starts flashing in the upper left hand corner of the LCD screen.

Press the hour button to advance the clock to the desired time. The hour numeral moves in one hour increments. When numeral passes 12 am, the "PM" indicator will illuminate in the lower left hand corner of the LCD screen.

Press the "minute" button to advance the minutes to the desired time. Minutes move in one second increments.

When complete, press the hour button again, or wait for 15 seconds and your time change will be accepted.

To Program the Brew Time

To program the brew time, press and hold the program button for two seconds. The "prog" symbol starts flashing in the lower right corner of the LCD screen.

Press the hour button to advance the clock to the desired time. The hour numeral moves in one hour increments. When numeral passes 12 am, the "PM" indicator will illuminate in the lower left hand corner of the LCD screen.

Press the "minute" button to advance the minutes to the desired time. Minutes move in one second increments.

When complete, press the "prog" button, or wait for 15 seconds and your set time will be accepted.

To Activate the Auto Brew Cycle

To activate the auto brew mode, depress the "auto on" button. The "auto" symbol will illuminate in the upper right hand corner of the LCD screen.

The unit will now begin the brewing cycle at the programmed time. When the programmed time initiates the cycle, the red "ON" indicator light will show that the brewing cycle has started.

NOTE: The unit will continue to attempt to brew at the programmed time, each day, until the Off button is pressed. The red “ON” indicator light will illuminate each time the attempt to brew is made.

If there is no water in the reservoir, the unit will automatically shut off one minute later.

MAKING COFFEE

1. Place coffeemaker on a solid flat surface. Plug into 120V outlet.
2. Open thermal carafe lid in direction of “OPEN” arrow. Fill thermal carafe with cold, fresh water. Open hinged water reservoir cover; pour water into reservoir opening. Markings on water level indicator show amount of water needed to make desired number of cups of coffee. **TO AVOID OVERFLOW, DO NOT FILL ABOVE 12 CUP MARK.** Close reservoir cover.
3. Before thermal carafe is returned to platform, prewarm carafe by running warm water through it. **Prewarming carafe will help keep coffee warmer.**
4. Return carafe lid to thermal carafe. To close lid, turn it in direction of “CLOSE” arrow until it fits tightly on carafe, and “POUR” arrow is aligned with spout. Return empty thermal carafe to platform. Be certain thermal carafe lid is in “CLOSED” position and is securely in place during brew cycle.
5. Open filter basket by grasping basket handle and swinging outward. Insert a filter into filter basket; make sure filter fits snugly in basket. Use a fresh filter for each carafe of coffee.
6. After placing 2 level tablespoons per cup of ground coffee into cone filter, return basket to closed position. To ensure safe operation, make sure basket is closed securely.
7. With thermal carafe and basket securely in place, press “ON” button; LED will light. **CAUTION:** Coffeemaker becomes very hot during brew cycle; handle with extreme care, as hot parts and escaping steam may cause burns.
8. The Brew-Through lid allows coffee to drip from coffeemaker through closed lid. When coffee has completely stopped dripping into thermal carafe and water level indicator is empty, brew cycle is complete. When dripping stops, Brew-Through lid will seal so coffee freshness and temperature are preserved.

9. An audible “beep” tone will signal when brew cycle is complete. The coffeemaker will switch off automatically.

Bottom of Thermal Carafe is hot to touch for several minutes after brewing. Use caution.

10. After coffee grounds have cooled, carefully open filter basket and discard used coffee filter and grounds. To remove filter basket from coffeemaker (A) grasp basket handle and swing basket outward, and (B) with basket in far right position, lift up and pull basket hinge.
11. Brew-Through lid allows coffee to be poured with lid in “CLOSED” position, so coffee freshness and temperature can be preserved. **NEVER POUR LIQUID FROM THERMAL CARAFE UNLESS LID IS IN “CLOSED” POSITION.**

BREW PAUSE™

This feature allows a cup of coffee to be poured before the brew cycle has finished. Carefully remove thermal carafe, and the Brew Pause™ feature will automatically activate, temporarily stopping flow of coffee into thermal carafe. Return thermal carafe to platform immediately after pouring coffee, and the brewing process will resume.

IMPORTANT: Carafe must be returned to its position within 30 seconds to prevent filter basket from overflowing.

NOTE: Strength of coffee poured mid-cycle may vary in strength from finished brew.

CAUTION: During brew cycle, basket must be closed securely since basket in improper position may cause hot water or coffee to overflow.

PRECAUTIONS

1. Do not place a cloth or otherwise restrict airflow beneath coffeemaker.
2. To avoid accidents, make sure thermal carafe lid is in “CLOSED” position during brewing and while pouring; do not pour in the direction of people.
3. When pouring, use thermal carafe handle only. **Bottom of Thermal Carafe is hot to touch for several minutes after brewing.**
4. **CAUTION:** Burns may result from spilled hot liquid and/or contact with hot parts.

CLEANING AND MAINTENANCE

Daily

Always unplug coffeemaker and allow to cool before cleaning. Wash filter basket in hot, soapy water. The carafe and lid can be washed in warm soapy water and rinsed thoroughly. Not recommended for use in dishwasher.

Do not use scouring agents or harsh cleansers on any part of the coffeemaker.

Never immerse base unit in water or other liquid. To clean base, simply wipe with a clean, damp cloth and dry before storing. Wipe resting plate with a clean, damp cloth. Never use rough, abrasive materials or cleansers to clean the resting plate. Do not dry the inside of the water reservoir with a cloth, as lint may remain.

Monthly

Minerals found in water can clog coffeemaker or reduce its efficiency. To prevent this, fill thermal carafe with 2 cups vinegar. Add cold water to top. Pour water/vinegar mixture into reservoir opening. Place empty thermal carafe (with lid securely closed) on platform and press "ON" button. After water/vinegar mixture has been cycled through, press "OFF" button. Rinse by cycling through 2 or 3 more carafes of plain cold tap water. Do not pour any liquid other than cold tap water or water/vinegar mixture into reservoir opening when cleaning.

FEATURES AND BENEFITS

1. Patented Lid

Allows coffee to brew in and pour out of carafe without opening or adjusting. Keeps coffee hot and flavorful for hours.

2. Reservoir Cover

Simply lift to fill with water. Close cover once water has been added.

3. Filter Basket

Swings open for easy insertion of coffee filter.

4. Water Window

Magnified markings indicate water needed to make corresponding cups of coffee.

5. Stainless Double-wall Thermal Insulated Carafe

6. Brew Pause™

Stops flow of water from basket when carafe is removed from heater plate, so a cup can be poured during brewing cycle.

7. Auto-Brew Cycle

Program time to brew.

8. "ON" Indicator Light

Illuminates when power is on.

9. LCD Readout

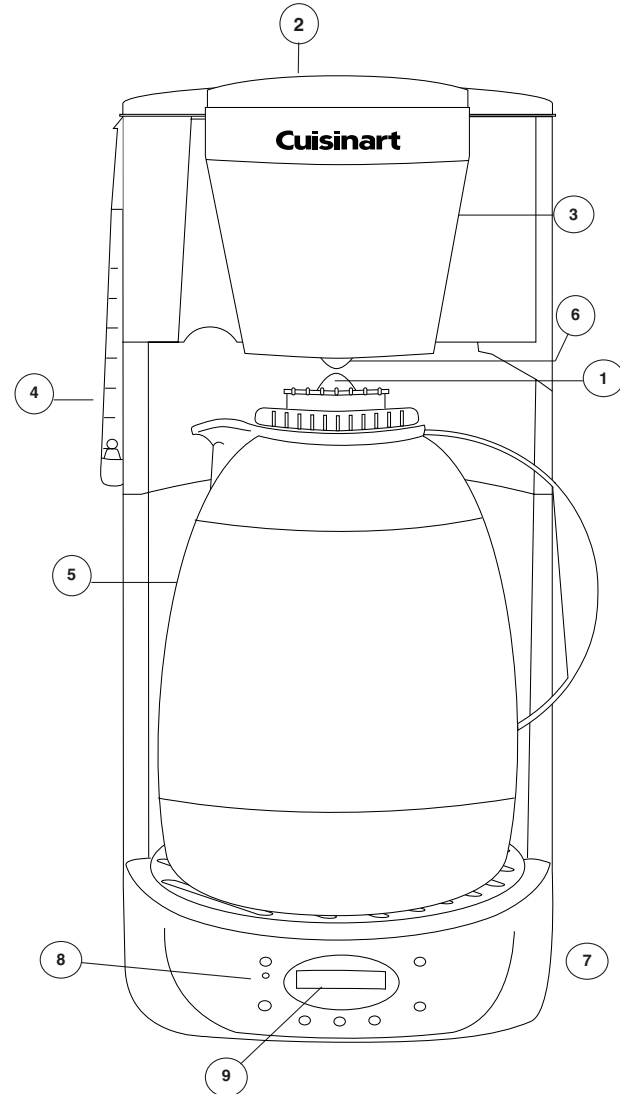

WARRANTY

THREE YEAR LIMITED WARRANTY

This warranty is available to consumers only. You are a consumer if you own a Cuisinart® Thermal Carafe Coffeemaker that was purchased at retail for personal, family or household use. Except as otherwise required under applicable state law, this warranty is not available to retailers or other commercial purchasers or owners.

We warrant that your Cuisinart® Thermal Carafe Coffeemaker will be free of defects in material or workmanship under normal home use for three years from the date of original purchase.

We suggest that you complete and return the enclosed product registration card promptly to facilitate verification of the date of original purchase. However, return of the product registration card does not eliminate the need for the consumer to maintain the original proof of purchase in order to obtain the warranty benefits. In the event that you do not have proof of purchase date, the purchase date for purposes of this warranty will be the date of manufacture.

If your coffeemaker should prove to be defective within the warranty period, we will repair it (or, if we think it necessary, replace it) without charge to you. To obtain warranty service, please call our Consumer Service Center toll-free at 1-800-726-0190 or write to:

Cuisinart
150 Milford Road
East Windsor, NJ 08520

To facilitate the speed and accuracy of your return, please also enclose \$10.00 for shipping and handling of the product (California residents need only supply proof of purchase and should call 1-800-726-0190 for shipping instructions). Please also be sure to include a return address, description of the product defect, product serial number and any other information pertinent to the product's return. Please pay by check or money order.

Your Cuisinart® Thermal Carafe Coffeemaker has been manufactured to strict specifications and designed for use only with the Cuisinart® Coffeemaker parts for your model. These warranties expressly exclude any defects or damages caused by accessories, replacement parts or repair service other than those that have been authorized by Cuisinart. These warranties do not cover any damage caused by accident, misuse, shipment or other than ordinary household use.

However, return of the warranty registration card is not a condition of this warranty and does not eliminate the need for the consumer to maintain the original proof of purchase.

In the event that you do not have proof of purchase date, the purchase date for purposes of this warranty will be the date of manufacture.

These warranties exclude all incidental or consequential damages. Some states do not allow the exclusion of or limitation of incidental or consequential damages, so the foregoing limitation or exclusion may not apply to you.

CALIFORNIA RESIDENTS ONLY

California law provides that for In-Warranty Service, California residents have the option of returning a nonconforming product (A) to the store where it was purchased or (B) to another retail store which sells Cuisinart® products of the same type. The retail store shall then, at its option, either repair the product, refer the consumer to an independent repair facility, replace the product or refund the purchase price less the amount directly attributable to the consumer's prior usage of the product. If either of the above two options does not result in the appropriate relief to the consumer, the consumer may then take the product to an independent repair facility if service or repair can be economically accomplished. Cuisinart, and not the consumer, will be responsible for the reasonable cost of such service, repair, replacement or refund for nonconforming products under warranty.

California residents may also, according to their preference, return nonconforming products directly to Cuisinart for repair or if necessary, replacement, by calling our Consumer Service Center toll-free at 1-800-726-0190. Cuisinart will be responsible for the cost of the repair, replacement and shipping and handling for such nonconforming products under warranty.

BEFORE RETURNING YOUR CUISINART® PRODUCT

If you are experiencing problems with your Cuisinart® product, we suggest that you call our Consumer Service Center at 1-800-726-0190 before returning the product for servicing. Often, our Consumer Service Representatives can help solve the problem without having the product serviced. If servicing is needed, a Representative can confirm whether the product is under warranty and direct you to the nearest service location.

*** Important:** If the nonconforming product is to be serviced by someone other than Cuisinart's Authorized Service Center, please remind the servicer to call our Consumer Service Center to ensure that the problem is properly diagnosed, the product is serviced with the correct parts and the product is still under warranty.

Cuisinart®

S A V O R T H E G O O D L I F E®



Coffeemakers



Food Processors



Toaster Ovens



Blenders



Cookware



Ice Cream Makers

Discover the complete line of Cuisinart® brand premier kitchen appliances including food processors, mini food processors, hand mixers, blenders, toasters, coffeemakers, cookware, ice cream makers and toaster ovens at

www.cuisinart.com

©2003 Cuisinart
Cuisinart® is a registered trademark of
Cuisinart
150 Milford Road
East Windsor, NJ 08520
Printed in China
www.cuisinart.com
03CU13398

IB-4830