

97050578
Rev.003
06/2015

CE
0051



2013

A3PLUS

EN

CONTENTS

1. Safety guidelines.....4	7. Hydrogroup operation34
1.1. Symbol definition.....4	7.1. Fill cup and bowl34
1.2. Intended use4	7.2. S.H.S. system (Simplified Hygienization System).....36
1.2.1. Classification4	7.3. WHE (Water Hygienization Equipment) system.....37
1.2.2. Environmental conditions5	7.4. Disinfection cycle with oxygenated water (manual BIOSTER cycle).....38
1.2.2.1. Transport and packaging conditions5	7.5. Automatic tool flushing cycle (FLUSHING)39
1.2.3. Warranty.....5	7.6. Opening/closing the side hydrogroup cover.....40
1.2.4. Disposing the equipment when no longer used.....5	
1.3. Safety rules5	8. Accessories41
1.4. Cleaning and disinfecting7	8.1. Operating lamp41
	8.2. Monitor on lamp pole.....43
2. Description of the equipment8	8.3. Negatoscope for panoramas.....43
2.1. Nameplate.....8	8.4. Air/water/230V quick-connect couplers.....43
2.2. Dental units8	
2.3. Dental chair9	9. Maintenance44
	9.1. Instrument maintenance.....44
3. Turning on the dental operatory9	9.2. Draining condensate44
	9.3. Cleaning the surgical suction filter44
4. Dental chair operation9	9.4. Surgical suction.....45
4.1. Safety devices.....10	9.5. CATTANI surgical separator.....46
4.2. Emergency devices.....10	9.6. CATTANI gravity amalgam separator.....46
4.3. Adjustable headrest10	9.7. Cleaning the turbine return air filter.....47
4.4. Movable armrests (optional).....11	9.8. METASYS amalgam separator47
	9.9. DURR amalgam separator.....47
5. Instrument board operation11	9.10. Dental chair47
5.1. Doctor's control console.....13	
5.1.1. Turning on the negatoscope.....14	10. Specifications.....48
5.1.2. Setting the dental chair "automatic return" and "rinse position".....14	10.1. A3PLUS CONTINENTAL dimensions49
5.1.3. Programming the chair positions A, B, C and D14	10.2. A3PLUS INTERNATIONAL dimensions50
5.1.4. Emergency stop button14	
5.2. Foot control15	11. Dental operatory maintenance plan51
5.2.1. "Multifunction" foot control.....15	
5.2.2. "Push-pedal" foot control.....16	
5.2.3. "Power Pedal" foot control18	
5.2.4. Wireless foot control.....19	
5.3. Syringe21	
5.4. Turbine22	
5.5. Micromotor23	
5.6. Scaler24	
5.7. T LED curing light.....25	
5.8. C-U2 dental camera28	
5.9. ZEN-Xi integrated sensor31	
6. Assistant's board operation.....31	
6.1. Assistant's touchpad32	
6.2. Syringe on assistant's board32	
6.3. Curing lamp on assistant's board.....32	
6.4. Intraoral camera system on assistant's board.....32	
6.5. Suction tubes33	
6.6. Hydraulic saliva ejector34	

1. Safety guidelines

- **These instructions describe how to use the A3PLUS dental units correctly.**
Carefully read and become familiar with the content of this manual before using the equipment.
- These instructions describe all the versions of the operating units with the maximum possible accessories, therefore not all the paragraphs are applicable to the unit you have purchased.
- No part of this manual is to be reproduced, stored in a retrieval system or transmitted in any form or by any means, i.e. electronic, mechanical, photocopying, translation or otherwise, without the prior written permission of Cefla sc - Cefla Dental Group.
- The information, technical specifications and illustrations contained in this publication are not binding.
 Cefla sc - Cefla Dental Group reserves the right to make technical improvements and changes without modifying the instructions contained herein.
- The manufacturer has a company policy of continual development. Although every effort is made to keep technical documentation up-to-date at all times some of the instructions, specifications and figures given in this manual may slightly differ from the purchased product. The manufacturer reserves the right to make changes without prior notice.
- The original version of this manual is written in Italian.
- This equipment is equipped with a device that prevents liquid back up.

1.1. Symbol definition

List of symbols used in this document to denote certain conditions:

1) Type of protection against direct and indirect contact: Class I. Type of protection against direct and indirect contact: Type B.	1		9		17	
2) WARNING! Failure to observe may result in equipment damage or injury to the user and/or patient.	2		10		18	SN
3) "Consult the instruction manual". Means that it is advisable to consult the instruction manual before using that part of the device.	3		11		19	 NW-0402BQ0101
4) NOTE: Identifies information that is especially important for the user and/or assistant.	4		12	 0051	20	REF
5) Earth ground. Functional earth connection.	5		13		21	
6) Alternating current.	6		14		22	
7) Part sterilized in autoclave.	7		15		23	
8) ON / OFF button.	8		16			
9) "Refer to the instruction manual". Means that for reasons of safety you need to consult the instruction manual before using the device.						
10) Open (a part of the unit).						
11) Closed (a part of the unit).						
12) Equipment in accordance with essential requirements of directive EEC 93/42 and subsequent changes (Class IIa equipment).						
13) Equipment in accordance with essential requirements of directive EEC 93/42 and subsequent changes (Class I medical equipment for ordinary use).						
14) Waste disposal symbol in accordance with Directives 2002/95/EC, 2002/96/EC and 2003/108/EC (valid only in the European Union).						
15) "Warning biological hazard". It provides information about possible risks of contamination deriving from contact with fluids, storage of infected biological waste.						
16) Manufacturer.						
17) Month and year of constructions.						
18) Apparatus serial number.						
19) DVGW mark (quality assurance kitemark regarding supply of drinking water).						
20) Product/equipment identification code.						
21) Do not push.						
22) Foot crushing hazard.						
23) Device equivalent to Class 2 light source.						

1.2. Intended use

- The A3PLUS series of operatories are medical devices intended for dental treatment.
- The instrument board may hold up to 6 instruments .
- The assistant's board can hold 2 suction tubes and 3 instruments.
- This equipment must be used only by adequately trained personnel (doctors and paramedics).
- The device is intended for **non-continuous operation** (see the operating times of the individual parts in the dedicated sections).
- The device is classified as pollution degree 2.
- Overvoltage class: II.

1.2.1. Classification

- MEDICAL DEVICES classification
 Classification of the dental unit in accordance with the indications given in annex IX of directive 93/42/EEC and subsequent changes: Class IIa
- ELECTRICAL MEDICAL EQUIPMENT classification
 Classification of the dental unit in accordance with standard EN 60601-1 for safety of medical equipment: **Class I - Type B.**
- Reference standards: A3PLUS series operatoriy units are designed and constructed in compliance with IEC 60601-1 3.a Ed. - 2007, IEC 60601-1-6 3.a Ed. - 2010, IEC 62366 1.a Ed. - 2007, IEC 80601-2-60 1.a Ed. - 2012, IEC 60601-1-2 3.a Ed., ISO 6875 3.a Ed. - 2011, ISO 7494-1 2.a Ed. - 2011 and EN 1717 (type AA and AB) standards as far as the water mains safety devices are concerned.
- Classification of RADIO DEVICES AND COMMUNICATION TERMINALS (only when the WIRELESS foot control is present)
 Equipment classification according to Directive 99/05/EC Art.12: **Class I.**

1.2.2. Environmental conditions

The equipment is to be installed in rooms that satisfy the following requirements:

- temperature between 10 and 40 °C;
- relative humidity between 30 and 75%;
- atmospheric pressure ranging from 700 to 1060 hPa;
- altitude ≤ 3000 m;
- air pressure entering equipment ranging from 6 to 8 bar;
- water hardness at the equipment inlet must not be above 25 °f (French degrees) or 14 °d (German degrees) for untreated drinking water. For water with a higher hardness degree, it is recommended to soften water until it reaches a hardness degree between 15 and 25 °f (French degrees) or between 8.4 and 14 °d (German degrees);
- water pressure entering equipment ranging from 3 to 5 bar;
- water temperature entering equipment not higher than 25 °C.

1.2.2.1. Transport and packaging conditions

- Temperature: from -10 to 70°C;
- Relative humidity: from 10% to 90%;
- Atmospheric pressure: from 500 to 1060hPa.

1.2.3. Warranty

Cefla sc - Cefla Dental Group stands behind its products warranting safety, reliability and performance.

The warranty is valid only under the following terms:

- The conditions given on the warranty certificate are observed.
- Performing yearly scheduled maintenance.
- The equipment is used only as instructed in this manual.
- The electrical wiring in the room in which the equipment is installed must conform to I.E.C. 60364-7-710 (standards for electrical wiring in medical and dental offices).
- A 3x1.5 mm² line protected by a bi-polar cut-out that conforms to applicable standards (10 A, 250 V, distance between contacts at least 3 mm) must be used to feed the equipment.



WARNING!

The color of the three wires (POWER, NEUTRAL and EARTH) should satisfy the requirements of current standards.

- Installation, repairs and, in general, any other operations requiring the casing to be opened are to be performed exclusively by personnel authorized by ANTHOS.

1.2.4. Disposing the equipment when no longer used

As set out in Directives 2002/95/ EC, 2002/96/ EC and 2003/108/ EC, on the restrictions of the use of certain hazardous substances in electrical and electronic equipment along with collection, treatment, recycling and disposal of waste electrical and electronic equipment the latter must be treated as municipal waste, therefore sorted and collected separately. When new equipment of equivalent type is purchased the waste equipment should be returned to the distributor on a one-to-one basis for disposal. As far as reuse, recycling and other forms of waste recovery mentioned above are concerned, the manufacturer is responsible for the actions specified by individual local laws.

Efficient collection of sorted waste separately to recycle and treat waste electrical and electronic equipment aids in preventing negative environmental impacts while protecting human health.

In addition it facilitates recycling of the materials used to construct the equipment.

Illegal waste disposal carries heavy fines defined by local laws.



WARNING!

The crossed out wheeled bin placed on the equipment indicates that the waste equipment must be collected separately from other waste.

1.3. Safety rules



WARNING!

- **All equipment is permanently installed.**

Depending on the type of chair the unit comes with, refer to the installation DATA given in paragraph "Specifications".

Cefla sc - Cefla Dental Group shall not be held liable for any personal injury or equipment damage resulting from failure to heed the precaution given above.

- **Floor conditions.**

The floor (continuous) should meet the load-bearing capacity set forth by DIN 1055, sheet 3. The weight of the dental unit including a 190 kg patient is about 350 kg/sq.m.

- This device may not be modified in any way without the authorisation of the manufacturer.

If the device is modified, appropriate examinations and tests need to be conducted in order to ensure continued safe use.

Cefla sc - Cefla Dental Group shall not be held liable for any personal injury or equipment damage resulting from failure to heed the precaution given above.

- **Dental chair**

The maximum chair capacity is 190Kg. This weight must never be exceeded.

- **Tray holders**

The maximum weights that can be held must never be exceeded:

- Instrument tray attached to the instrument board maximum allowable load 2 Kg, evenly distributed.
- Instrument tray attached to the instrument board maximum allowable load 1 Kg, evenly distributed.

- **Connections to external instruments**

The equipment can be hooked up only to other instruments that bear the CE mark.

- **Electromagnetic interferences.**

Use of electrical equipment that does not comply to standard IEC 60601-1 3.a Ed. - 2007 in the office or nearby may cause electromagnetic or other types of interferences resulting in dental unit malfunctions.

In these cases, shut off power to the dental unit before using this equipment.

- **Replacing the chucks**

Operate the turbine release and contra angle only once the chuck has come to a complete stop. On the contrary, the locking system will wear down and the chucks can slip off causing injury. Use exclusively quality drills with an attachment stem of calibrated diameter (1590-1600 mm in compliance with ISO 1797-1). To check the state of the locking system, make certain the chuck is firmly secured to the instrument every day before

starting work. Locking system defects caused by misuse are easily identified and not covered by the warranty.

- **Patients with pace makers and/or hearing aids.**

When treating patients with pace makers and/or hearing aids, take into consideration the effects the instruments may have on pace makers and/or hearing aids. Carefully read technical-scientific information available on this subject.

- **Implants.**

If the dental unit is used for implant operations using separate equipment designed for this purpose, shut off power to the dental chair (see Paragraph 3.) to avoid unwanted movements resulting from faults and/or accidental start up of the controls.

- Do not forget to turn off the office's water supply and master switch on the equipment before leaving the surgery.
- The equipment is not protected against liquid penetration (IPX O).
- The device is not suitable for use in the presence of flammable anaesthetic gas mixed with air, oxygen or nitrous oxide (N₂O).
- This equipment must be stored properly so that it is kept in top working order at all times. The manufacturer shall not be held responsible for misuse, carelessness or improper use of the equipment.
- This equipment is to be used exclusively by qualified personnel (doctors and paramedics) with the proper training.
- The user must be present at all times When the equipment is turned on or ready for start-up. In particular, never leave the equipment unattended in the presence of children/the mentally disabled or other unauthorised personnel in general.

Any companions must keep out of the area in which treatment is performed and in any case under the responsibility of the operator. The area in which treatment is performed refers to the space around the dental unit plus 1.5 meters.

- **Quality of the water delivered by the dental unit.**

The user is responsible for the quality of the water delivered by the dental unit and must adopt measures to maintain it.

To ensure that you meet the water quality requirements, Cefla sc - Cefla Dental Group advises you to equip the dental unit with an internal or external disinfection system.

Once installed, the dental unit is exposed to contaminants originating from the water supply. For this reason, it is recommended to install and put it into operation only when you begin using it daily and to perform the decontamination procedures described in the relative chapters right from the first day of installation.

If the dental unit is equipped with a device for separation from the open water supply system (EN 1717), make sure that it also continuously adds disinfectant as required and check that the relative tank contains an adequate quantity (see the relative paragraph).

NOTE: contact your local dealer or Dental association for more detailed information about national laws and requirements.

- **Applied Parts.**

The parts of the device that during normal use necessarily come into contact with the patient for the device to be able to perform its functions are: Dental chair upholstery, armrest, polymerising lamp fibre optics, terminal part of the syringe, single-use camera protection, scaler bits, drill handpieces, cannula suction terminals.

Non applied parts that may come into contact with the patient are: dental chair armrest support, dental chair lower casing, patient-side hydro unit casing, cup water delivery spout, bowl, suction tubes, handpiece body.

- **WARNING! Moving the dental chair.**

Make sure that the patient is ready to collaborate: ask him/her to keep his/her hands and feet close, avoiding incorrect postures.

Check that the patient is sitting properly when moving the dental chair (see figure).

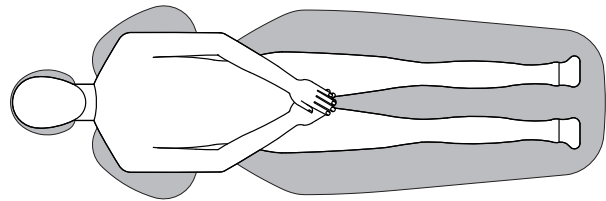

1.4. Cleaning and disinfecting

Cleaning is the first step of any disinfecting process. Physically scrubbing with detergents and surface-active substances and rinsing with water removes a considerable amount of micro organisms. If a surface is not clean first, the disinfecting process cannot be successful. If a surface cannot be adequately cleaned, it should be protected with barriers.

The outer parts of the equipment must be cleaned and disinfected using a product for hospital use with indications for HIV, HBV and tuberculocide (medium-level disinfectant) specifically for small surfaces.

The various drugs and chemical products used in dentist's surgeries may damage the painted surfaces and the plastic parts.

Research and tests run show that the surfaces cannot be fully protected against the harsh action of all products available on the market. We therefore recommend protecting with barriers whenever possible. The harsh actions of chemical products also depend on the amount of time they are left on the surfaces. It is therefore important not to leave the product on the surfaces longer than the time specified by the manufacturer.

It is recommended to use the specific medium-level disinfectant, **STER 1 PLUS** (CEFLA S.C.), which is compatible with:

- Coated surfaces and plastic parts.
- Upholstery.



WARNING!

The **VISCOELASTIC** upholstery will stain when splashed with mordant acid. Immediately rinse with plenty of water if acid spatters on the upholstery.

- Uncoated metal surfaces.

If you do not use **STER 1 PLUS**, it is recommended to use products that contain at maximum:

- **Ethanol 96%**. Concentration: maximum 30 g per 100 g of disinfectant.
- **1-propanol (N-propanol, propyl alcohol, N-propyl alcohol)**. Concentration: maximum 20 g per 100 g of disinfectant.
- **Combination of ethanol and propanol**. Concentration: the combination of the two should be maximum 40 g per 100 g of disinfectant.



WARNING!

- Do not use products containing isopropyl alcohol (2-propanol, iso-propanol).
- Do not use products that contain sodium hypochlorite (bleach).
- Do not use cleaners that contain phenol.
- Do not spray the selected products directly on the surfaces.
- All products must be used as directed by the manufacturer.
- Do not mix the **STER 1 PLUS** disinfectant with other products.

Cleaning and disinfecting instructions.

Clean and disinfect with single-use non-abrasive paper (avoid using recycled paper) or sterile gauze.

Do not use sponges or in any case, any material that can be reused.



WARNING!

- Shut off the dental unit prior to clean and disinfecting the external parts.
- All material used to clean and disinfect must be thrown away.

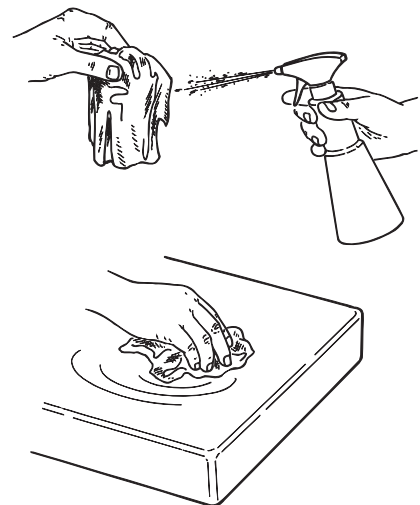
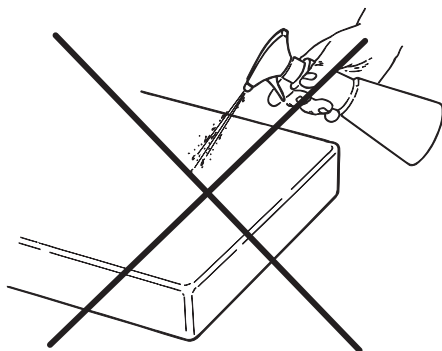

2. Description of the equipment

2.1. Nameplate

Dental operatory

The nameplate is found on the arm between the dental chair and hydrogroup.

Data given on plate:

- Manufacturer's name
- Name of equipment
- Voltage
- Type of current
- Frequency
- Maximum power absorbed
- Serial number
- Month and year of construction

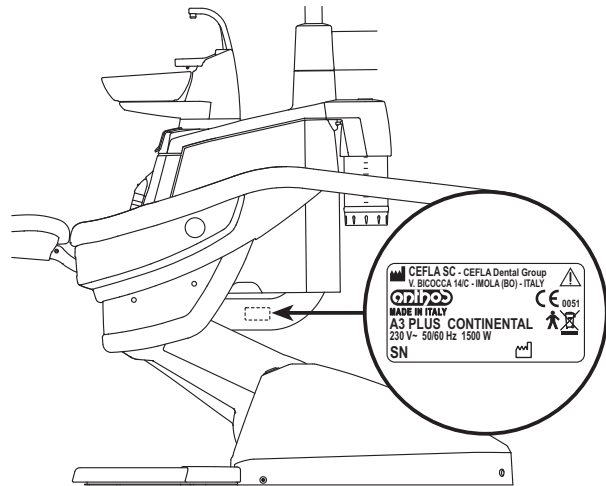

2.2. Dental units

The dental units of the **A3PLUS** series come in the following models:

Model A3PLUS CONTINENTAL CONTINENTAL version

"CONTINENTAL" version instrument board (instruments will return to their original position through the pulling action of the spring-operated arms) attached to a double supporting arm, one of which is articulated while the other is autobalancing.

Description of equipment:

- a Hydrogroup
- b Adjustable arm
- c Instrument board
- d Doctor's console
- e Tray holder
- f Assistant's board
- g Assistant's control console
- h Utility service center
- i Multifunction foot control
- l Water to cup
- m Bowl
- n Autobalancing arm
- z ANTHOS A1.3 dental chair

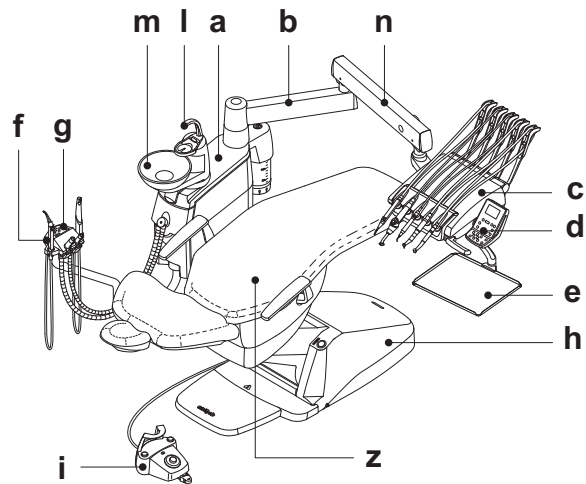

Model A3PLUS INTERNATIONAL

"INTERNATIONAL" version instrument board (instruments placed vertically in housings) attached to a double supporting arm, one of which is articulated while the other is autobalancing.

Description of equipment:

- a Hydrogroup
- b Adjustable arm
- c Instrument board
- d Doctor's console
- e Tray holder (optional)
- f Assistant's board
- g Assistant's control console
- h Utility service center
- i Multifunction foot control
- l Water to cup
- m Bowl
- n Autobalancing arm
- r Negatoscopio per panoramiche (optional)
- z ANTHOS A1.3 dental chair

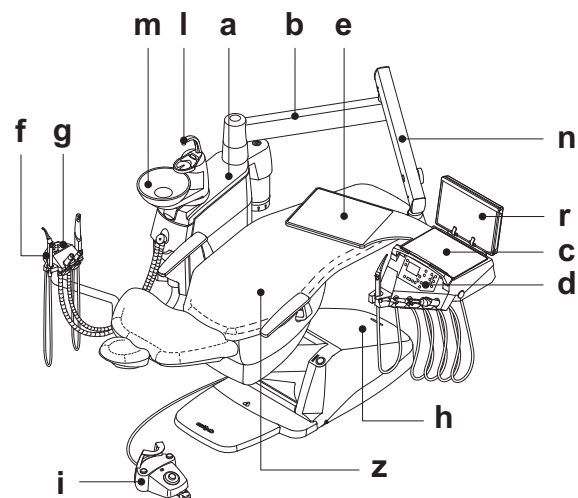

2.3. Dental chair

Description of the chair

- a Headrest.
- b Back.
- c Safety foot board.
- d Movable arm (optional).

Operating times

The operating and rest times are as follows: **work 25 sec. - rest 10 min.**

Maximum weight capacity.

The maximum chair capacity is 190 Kg.



WARNING!

Do not exceed this value.

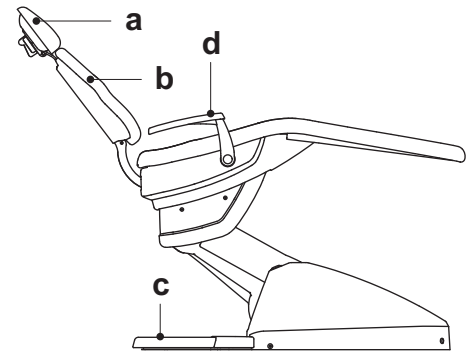

Warnings for use.



WARNING: FOOT CRUSHING HAZARD

Pay attention to the patient and the staff during dental chair descent.

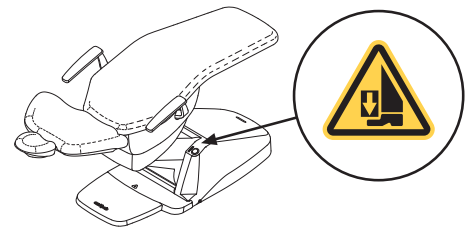

3. Turning on the dental operatory

Press the master switch (f) and check the following on the control console:

- **“POWER” led (g) off**
 - equipment off
 - pneumatic system disconnected
 - water system disconnected
- **“POWER” led (g) (A3P) on**
 - equipment on
 - pneumatic system connected
 - water system connected.

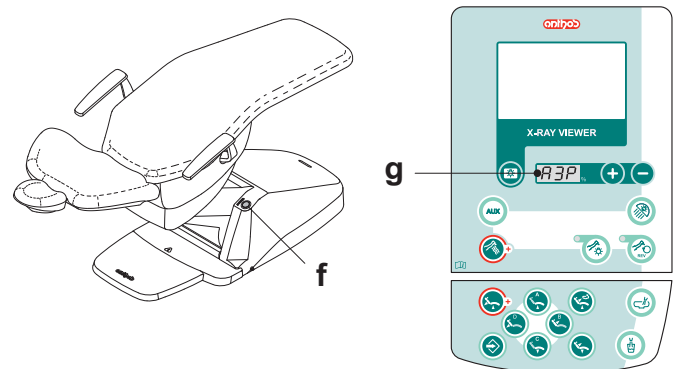

4. Dental chair operation

The dental chair can be moved as follows:

- Chair seat up/down
- Back up/down with inclination of the chair seat (Trendelenburg compensated)

The dental chair can be operated from the following places:

- Instrument board (a) (see par. 5)
- Multifunction foot control (b) (see par. 5.2)
- Assistant's board (c) (see par. 6)

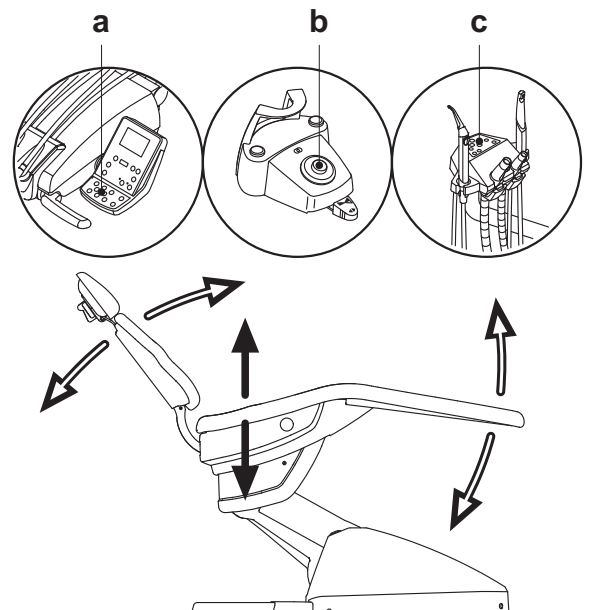

4.1. Safety devices

The equipment is supplied with the following safety devices:

- The floor box is equipped with a device (**l**) that immediately stops the dental chair from moving down in the presence of an obstacle and automatically lifts it up to free the obstacle.
- The backrest is equipped with a device (**m**) that immediately stops the backrest from moving down in the presence of an obstacle and automatically lifts it up to free the obstacle.
- The arms of the assistant's board are equipped with a safety device (**n**) that immediately stops the dental chair from moving down if an obstacle is encountered and automatically moves it up to clear the obstacle.

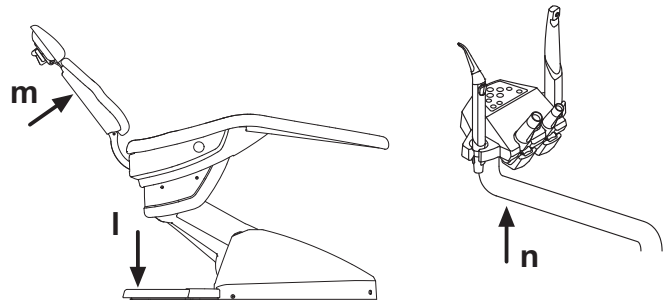

4.2. Emergency devices

WARNING!

Use the devices below when movement of the equipment needs to be blocked:

- **Dental chair control buttons (a) or (c).**
Pressing any dental chair button blocks all movements.
- **Foot control (b).**
When the foot control is actuated, all movements of the equipment are blocked.
- **Foot board (i).**
Foot board activated: all movements are blocked.

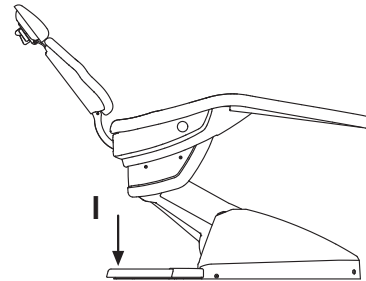
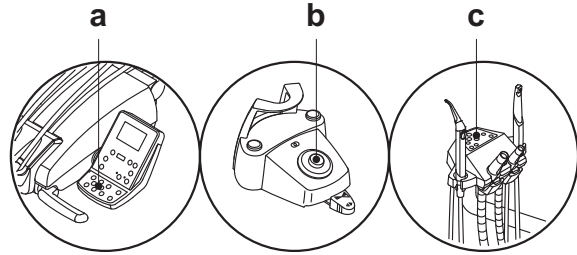

4.3. Adjustable headrest

The headrest may be of two types:

- 1 with manual cushion lock lever
- 2 with pneumatic cushion lock lever

Adjusting headrest height.

- with manual locking (**1**):
The head rest blade is positioned through a magnetic clutch. The operator should pull up and/or push down the headrest until it is in the desired position.
- with pneumatic locking (**2**):
Press and hold down the locking button (**u**) to position the headrest as desired. Once you have reached the desired position, release the button (**u**) to lock the headrest in place.

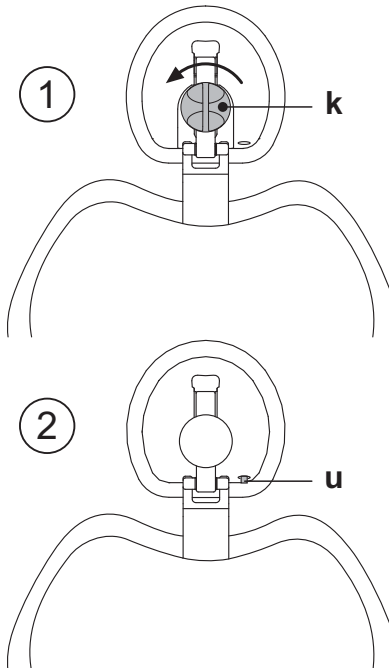

Adjusting the cushion:

- with manual lock (**1**): rotate the lock knob (**k**) anti-clockwise, position the cushion as desired and then retighten the lock knob.
- with pneumatic lock (**2**): press the lock button (**u**) and keep it pressed as you adjust the cushion as desired. Once the cushion is oriented as desired just release the button (**u**) to lock in place.

Proper positioning of the headrest.

WARNING!

For correct use of the headrest, position the patient's head as shown in the figure.

Important information.

WARNING!

- **Maximum on-headrest load: 30 Kg.**
- **Do not attempt to move cushion while patient is resting against it.**
- **Do not attempt to modify the position of the cushion without first releasing the lock mechanism.**
- **The pneumatic locking device is active only when the air circuit is pressurized and the dental unit is on.**

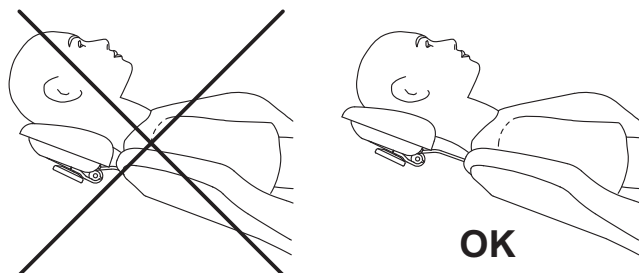

4.4. Movable armrests (optional)

Both arm rests are movable and can be turned downwards so that the patient can more conveniently get on and off the chair.



WARNING!

- Maximum weight supported by armrest: 68 kg.

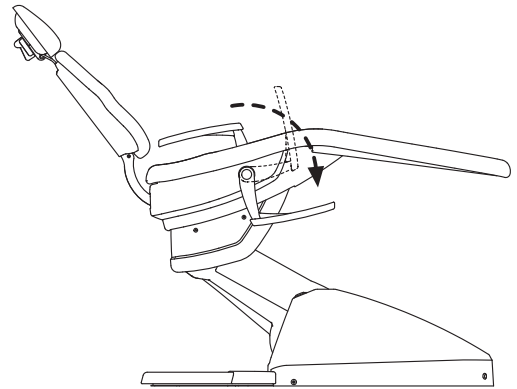

5. Instrument board operation

Layout of instruments

The positions the instruments are placed in on the board are determined by the customer at the time of order.

Starting the instruments.

- The syringe is always on (see paragraph 5.3.).
- The curing light is turned on with the key when the instrument is withdrawn (see paragraph 5.7.).
- Intraoral camera turn on when the instrument is extracted (see paragraph 5.8.).
- If connected to an external PC, the integrated ZEN-Xi sensor is always operative (see paragraph 5.9.).
- Once picked up, all the instruments are operated with the foot control. (see paragraph 5.2.).

Simultaneous use of the instruments

A device sees that the instruments cannot be used simultaneously. The first instrument removed is operative while those removed there after are deactivated by this device. This device allows the chuck to be replaced in one instrument while another is used on the patient.

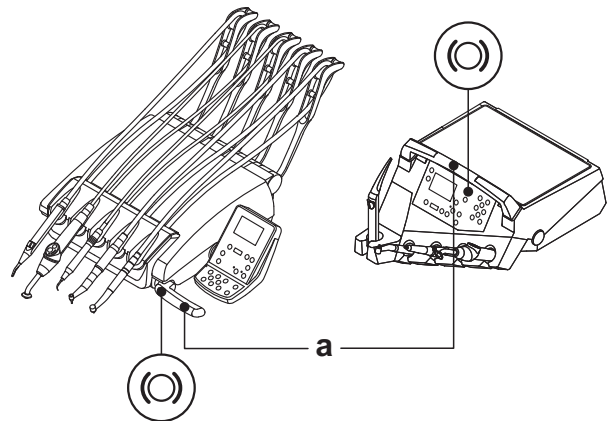

Positioning the instrument board.

The instrument board can move in all directions. To adjust the height of the board and/or direct it horizontally, simply grasp the handle (a).

NOTE (only for pantograph arm with pneumatic brake): to adjust the height of the dentist's instrument board, you first need to press the brake release button (c).

Pantograph arm.

There are two types of pantograph arm:

- ① with manual locking
- ② with pneumatic locking

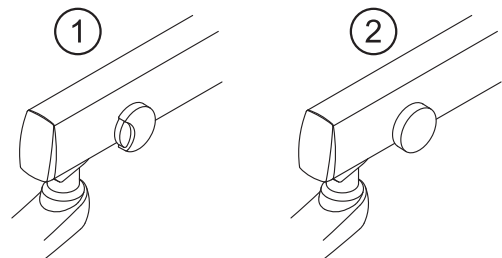

Adjusting the pantograph arm with manual brake.

Balancing of the pantograph arm is determined at the time of installation. Any future adjustments can be made using the knob (b) found on the pantograph arm.

Turn clockwise: to increase clutching of the pantograph arm.
Turn counter-clockwise: to decrease clutching of the pantograph arm.

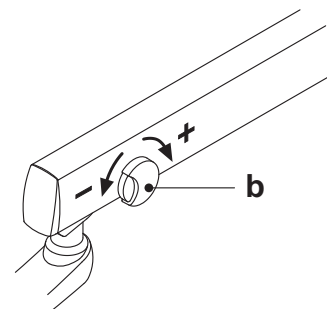

Instrument return arm stopping device (only for CONTINENTAL version dentist's instrument boards).

If this device is provided, the instrument return arm can be locked in the instrument extracted position.

When the device is used a click is heard about 2/3 of the total arm travel. To go back to the original condition, simply move the arm to the end of its travel (**A**).

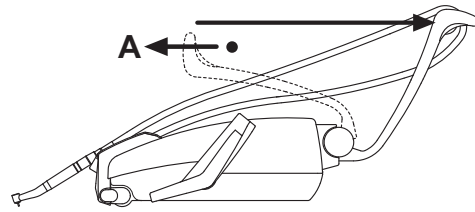

Tray holder module for CONTINENTAL version dentist's instrument board.

The tray holder module (**f**) is made of stainless steel and can easily be removed from its support.

! WARNING!

Maximum permitted load on the tray holder module (**f): 2 kg distributed.**

Tray holder module for INTERNATIONAL version dentist's instrument board.

! WARNING!

Maximum permitted load on the tray holder module (**e): 2 kg distributed.**

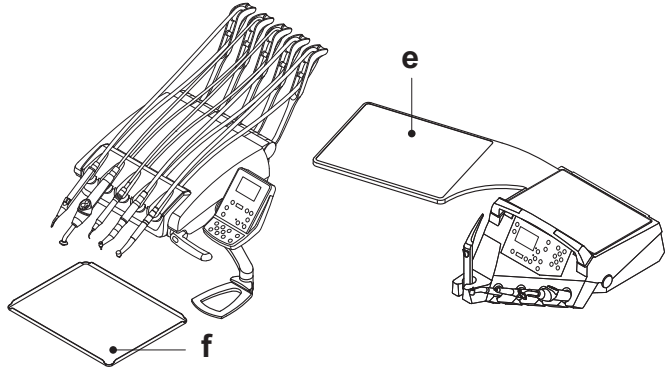

Cleaning the instrument board handle.

Clean the dentist's module handle using a suitable product (see Paragraph 1.4).

Cleaning the dentist's instrument board.

Clean the dentist's instrument board using a suitable product (see paragraph 1.4).

! NOTE for CONTINENTAL version dentist's instrument boards: the instrument holder (**x**) can be removed to facilitate the cleaning operations; to remove it, simply pull it out of its seat as it is only secured with magnets.

The silicone instrument holder (**u**) can also be sterilized in an autoclave at 121°C (rubber cycle).

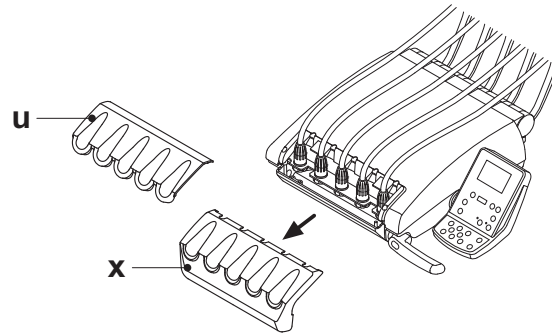

Instrument cords.

Clean the instrument cord using a suitable product (see Paragraph 1.4).

5.1. Doctor's control console

The following touchpad controllers are provided in dental units models A3PLUS:

- 1 Pushbutton panel for the models:
A3PLUS CONTINENTAL
- 2 Pushbutton panel for the models:
A3PLUS INTERNATIONAL

Description of the buttons:

- INCREASE button: increases the settable values.
- DECREASE button: decreases the settable values.
- Operating lamp on/off button.
- Fibre optic lighting ON/OFF button with relative functioning LED.
- Micromotor rotation direction inversion control button with relative functioning LED.
- Negatoscope on/off button on console.
- Auxiliary function button (available).
- FLUSHING cycle activation button.
- Water to bowl button.
- Water to cup button.
- Dentist's instrument board brake release button. (only A3 PLUS INTERNATIONAL models)
- Dental chair position storage button.
- Emergency position recall button.
- Home position recall button.

- NOTE:** operation of dental chair buttons:
- Button pressed shortly: set position automatically reached.
 - Button held down: positioned reached by hand.

Indicator lights:



- Display for viewing:
- power or speed of the dynamic instruments,
 - storage function enabled,
 - FLUSHING cycle activation.

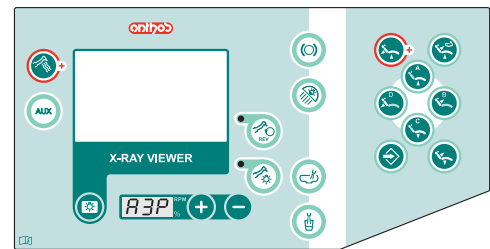
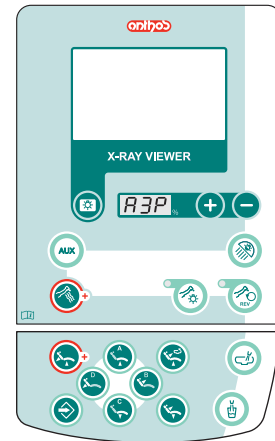

- Rinsing position recall button.
- Seat up and programmed position A recall button.
- Backrest up and programmed position B recall button.
- Seat down and programmed position C recall button.
- Backrest down and programmed position D recall button.

5.1.1. Turning on the negatoscope

Press the ON/OFF button.



NOTE: negatoscope shut off is timed and takes place 2 minutes after it was turned on.

5.1.2. Setting the dental chair "automatic return" and "rinse position"

- Bring the dental chair into the desired position with the manual movements buttons.
- Hold button "SAVE" for at least 2 seconds to activate memory mode. Storage mode activation is signalled by a short beep and by the flashing 0 on the console display.

NOTE: hold down button "SAVE" for at least 2 seconds to quit without saving the changes made.

- Press the "Automatic Return" or "Rinsing Position" buttons to associate the position with the button (e.g. "Rinsing Position").

NOTE: the number for the selected button lights up on the display to confirm the position has been saved.

5 = AUTOMATIC RETURN
6 = RINSE POSITION

NOTE: the "RINSE POSITION" button brings the chair back into the rinse position without changing the position of the chair seat. When the button is pressed again, the back goes back to the previous position.

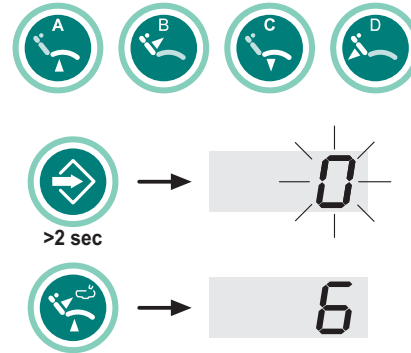

5.1.3. Programming the chair positions A, B, C and D

- Bring the dental chair into the desired position with the manual movements buttons.
- Hold button "SAVE" for at least 2 seconds to activate memory mode. Storage mode activation is signalled by a short beep and by the flashing 0 on the console display.

NOTE: hold down button "SAVE" for at least 2 seconds to quit without saving the changes made.

- Push the A, B, C or D keys to associate the relevant position to the key (e.g. C).

NOTE: The number of the button selected (e.g. 3) will be shown on the console display to confirm that it has been stored.

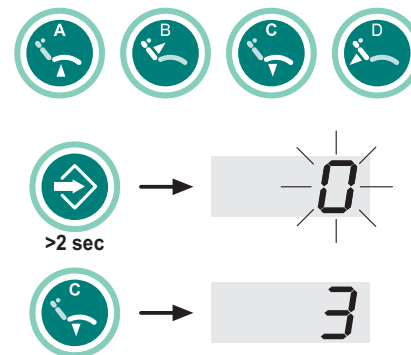

5.1.4. Emergency stop button

This button can be used in the event of an emergency to bring the patient into the Trendelenburg position.

NOTE: the Trendelenburg position is already set and cannot be changed.



5.2. Foot control

Three types of foot controls are available:

- 1 "Multifunction" foot control.
- 2 "Push-pedal" foot control.
- 3 "Power Pedal" foot control.

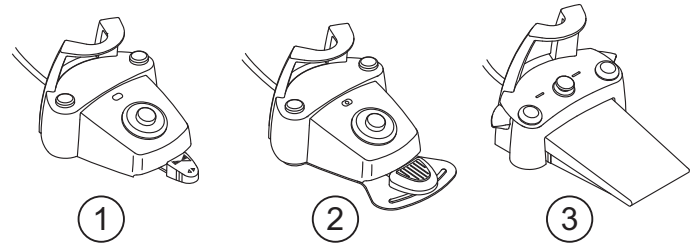

NOTE: the "multifunction" and "pressure" foot controls can also be supplied in wireless version.

5.2.1. "Multifunction" foot control

Description of the parts.

- 1 Handle.
- 2 Control pedal.
- 3 Dental chair movements.
- 4 Chip-air/patient rinsing position control.
- 5 Water Clean System/Automatic dental chair return control.
- 6 LED (not active).
- 7 Battery charge LED (wireless version only).

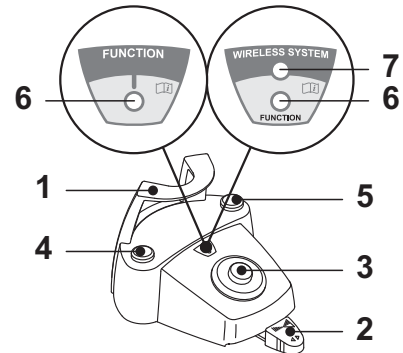

Control pedal (2).

With instrument removed

- Starts the instrument.
- Adjusts the rpm of rotary instruments.
- To right: operation with spray (if foreseen for selected instrument).

NOTE: at the end of work, air is automatically blown to eliminate any drops of liquid remaining in the spray ducts.

- To left: spray-free operation.

With instruments in place

- Fully right: dental chair automatic return (RA).
- Fully left: patient rinse position reached (PR).

NOTE: if the pedal is pushed fully left again, the dental chair moves back to the work position.

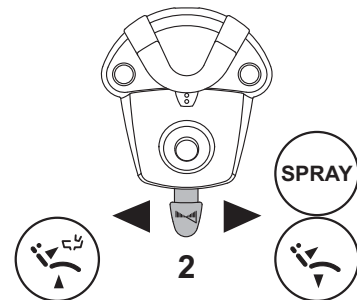

WARNING!

These dental chair functions are activated by keeping the pedal at the end of the travel for at least 2 seconds.

Joystick for dental chair movement (3).

These buttons move the dental chair as follows:

- Dental chair seat up.
- Dental chair backrest up.
- Dental chair seat down.
- Dental chair backrest down.

To stop movement, release the button.

NOTE: all the buttons used to move the dental chair are inoperative when an instrument is removed and the foot control pedal is actuated.

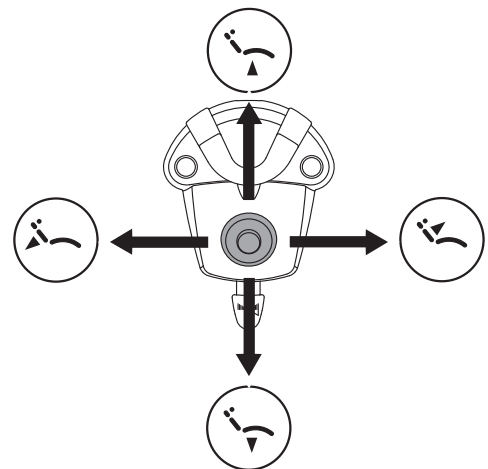

Left-hand button operation (4).

- **Key held down (at least 2 seconds) with the instrument removed:**
Chip-air operation: delivers air to the turbine or micromotor.
Air is delivered by pressing the button. Air is no longer blown when the button is released.
 - **Key held down (at least 2 seconds) with the instruments in place:**
"Rinse position" (PR) program activated.
- NOTE:** press the key again to bring the chair back to the work position.

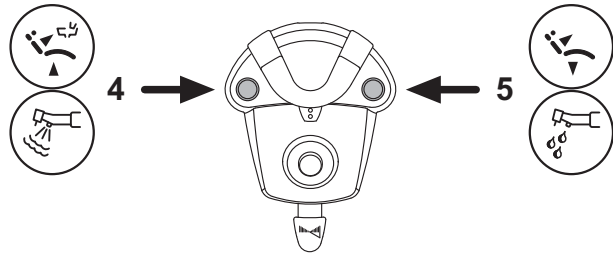

Right-hand button operation (5).

- **Key held down (at least 2 seconds) with the instrument removed:**
Water Clean System operation: running water is sent to the instruments such as the turbine, micromotor and scaler to flush the spray ducts.
Water is delivered by pressing the button. Water is no longer delivered when the button is released and air is automatically blown to eliminate any drops of liquid remaining in the spray ducts.
- **Key held down (at least 2 seconds) with the instruments in place:**
"Dental chair automatic return" program activated.

Wireless version.

This foot control can also be supplied in wireless version (see Paragraph 5.2.4).

Protection against liquid penetration.

The foot control is protected against liquid penetration. Degree of protection: IPX1.

Cleaning.

Clean the foot control using a suitable product (see Paragraph 1.4).

NOTE: if the foot control slips on the floor, dust the slip-proof rubber found under the base with a dry cloth.

5.2.2. "Push-pedal" foot control

Description of the parts

- 1 Handle.
- 2 Control pedal.
- 3 Dental chair movements.
- 4 Chip-air/patient rinsing position control.
- 5 Water Clean System/Automatic dental chair return control.
- 6 Spray operation LED.
- 7 Battery charge LED (wireless version only).

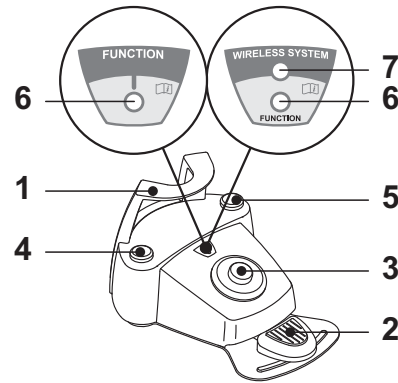

Control pedal (2).

- Operation:
- Remove the instrument.
 - Push the foot pedal to start the instrument (a).
 - Adjust the rpm/power of the instrument with the control pedal:
 - to right: to increase;
 - to left: to decrease.

NOTE: the control pedal adjusts the speed/power of the instrument from the minimum to the maximum value set from the instrument board.

- To stop the instrument, simply release the control pedal (a).

NOTE: with the spray active, at the end of the operation a blast of air is automatically activated to remove any residual drops of liquid in the spray ducts.

WARNING!

Instrument spray is activated and deactivated by pressing the buttons (4) or (5).



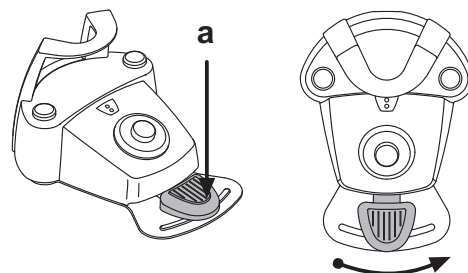

A beep sounds to signal the operating status has been changed.

When the LED (6) is on, it indicates operation with spray.



Joystick for dental chair movement (3).

These buttons move the dental chair as follows:

-  Dental chair seat up.
-  Dental chair backrest up.
-  Dental chair seat down.
-  Dental chair backrest down.

To stop movement, release the button.

 **NOTE:** all the buttons used to move the dental chair are inoperative when an instrument is removed and the foot control pedal is actuated.

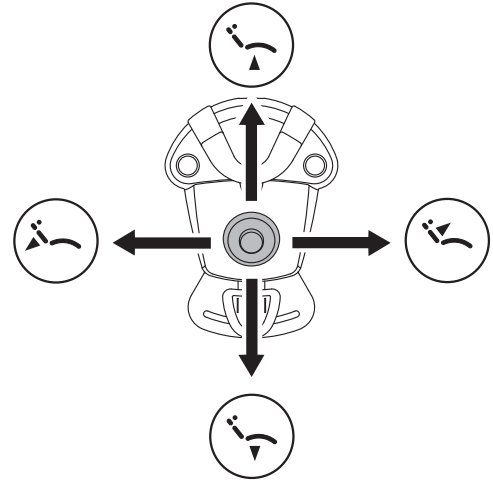

Left-hand button operation (4).

Operation:

- Holding down the button for at least 2 seconds with the instruments in rest position:

Activation of the "Patient rinsing position" program.

 **NOTE:** pressing the button a second time returns the dental chair into working position.

- Holding down the button for at least 2 seconds with instrument extracted:
Chip-air control: sends a jet of air to the turbine or the micromotor.
Air delivery is activated by pressing the button; the jet of air is interrupted when the button is released.

 **NOTE:** the control works only when the turbine and micromotor are in working position.

- Briefly pressing the button with the instrument extracted:
Activation or deactivation of instrument spray.

 **WARNING!**

A short acoustic signal warns of the switch.

When the LED (6) is on, it indicates operation with spray.

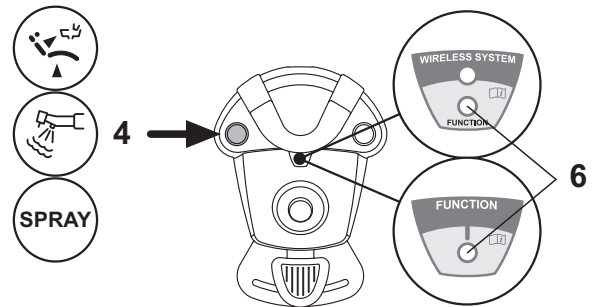

Right-hand button operation (5).

Operation:

- Holding down the button for at least 2 seconds with the instruments in rest position:

Activation of the "Automatic dental chair return" program.

- Holding down the button for at least 2 seconds with instrument extracted:
Water Clean System control: sends a jet of running water to instruments such as the turbine, the micromotor and the scaler for rinsing the spray ducts.

Water delivery is activated by pressing the button (4); when the button is released, the jet of water is interrupted and a blast of air is automatically activated to remove any residual drops of liquid in the spray ducts.

- Briefly pressing the button with the instrument extracted:
Activation or deactivation of instrument spray.

 **WARNING!**

A short acoustic signal warns of the switch.

When the LED (6) is on, it indicates operation with spray.

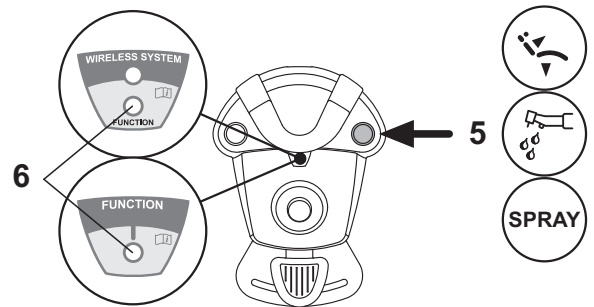

Wireless version.

This foot control can also be supplied in wireless version (see Paragraph 5.2.4).

Protection against liquid penetration.

The foot control is protected against liquid penetration. Degree of protection: IPX1.

Cleaning.

Clean the foot control using a suitable product (see Paragraph 1.4).

 **NOTE:** if the foot control slips on the floor, dust the slip-proof rubber found under the base with a dry cloth.

5.2.3. "Power Pedal" foot control

Description of the parts.

- 1 Handle.
- 2 Foot control.
- 3 Dental chair movements.
- 4 Chip-air control or activation/deactivation of instrument spray function.
- 5 Water Clean System control or activation/deactivation of instrument spray function.
- 6 Program "B" retrieval or patient rinse position activation.
- 7 Program "A" retrieval or automatic dental chair return activation.
- 8 Spray operation LED.

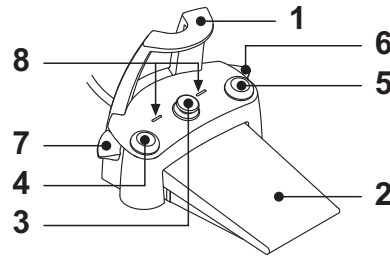

Foot control operation (2).

• With instrument removed

- Pushing the pedal (a), the instrument is started.
The instrument's rpm (or power) can be adjusted by varying the pressure exerted on the foot control.

NOTE: the foot control adjusts the speed/power of the instrument from the minimum to maximum value set from the instrument board.

- Release the foot control to stop instrument operation.

NOTE: with the spray active, at the end of the operation a blast of air is automatically activated to remove any residual drops of liquid in the spray ducts.

• With instrument in place

- When the foot control is pressed, all automatic dental chair movements are automatically blocked.

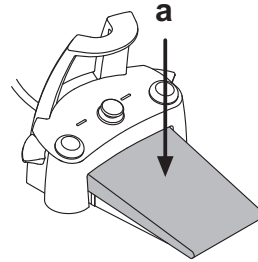

Dental chair movement joystick operation (3).

Controlla i seguenti movimenti:

- Chair seat up
- Chair back up
- Chair seat down
- Chair back down

To stop movement, release the button.

NOTE: all dental chair movements are blocked when an instrument is being used or the BIOSTER system is running.

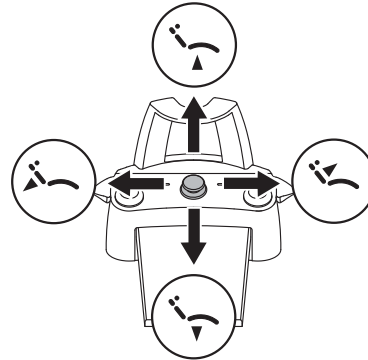

Left-hand button operation (4).

- Holding down the button for at least 2 seconds with instrument extracted:
Chip-air control: sends a jet of air to the turbine or the micromotor.
Air delivery is activated by pressing the button; the jet of air is interrupted when the button is released.
- Briefly pressing the button with the instrument extracted:
Activation or deactivation of instrument spray.

WARNING!

A short acoustic signal warns of the switch.
When the LED (8) is on, it indicates operation with spray.

Right-hand button operation (5).

- Holding down the button for at least 2 seconds with instrument extracted:
Water Clean System control: sends a jet of running water to instruments such as the turbine, the micromotor and the scaler for rinsing the spray ducts. Water delivery is activated by pressing the button (5); when the button is released, the jet of water is interrupted and a blast of air is automatically activated to remove any residual drops of liquid in the spray ducts.
- Briefly pressing the button with the instrument extracted:
Activation or deactivation of instrument spray.

WARNING!

A short acoustic signal warns of the switch.
When the LEDs (8) are on, they indicate operation with spray.

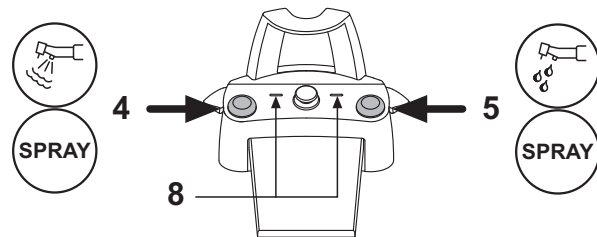

Right lever operation (6).

NOTE: the lever functions only with the instruments in their rest position.

For safety reasons, the selected function starts only after the switch has been briefly actuated and then released.

- **Lever pushed down:**
"Dental chair automatic return" program activated.
- **Lever pulled up:**
Dental chair program "B" start.

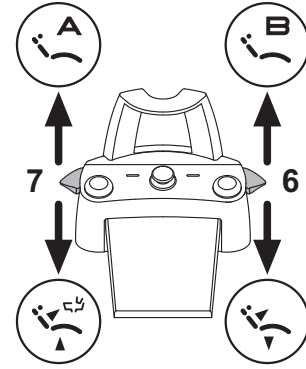

Left lever operation (7).

NOTE: the lever functions only with the instruments in their rest position.

For safety reasons, the selected function starts only after the switch has been briefly actuated and then released.

- **Lever pushed down:**
"Rinse position" (PR) program activated.

NOTE: when the switch is actuated the second time, the dental chair reaches its work position.

- **Lever pulled up:**
Dental chair program "A" start.

Protection against liquid penetration.

The foot control is protected against liquid penetration.
Degree of protection: IPX1.

Cleaning.

Clean the foot control using a suitable product (see Paragraph 1.4).

NOTE: if the foot control slips on the floor, dust the slip-proof rubber found under the base with a dry cloth.

5.2.4. Wireless foot control

The "multifunction" and "pressure" foot control can also be supplied in wireless version.
The wireless foot control contains a ZIGBEE transmitter module (module certified for Europe, Canada and the USA).

Warnings for use.



WARNING!

- Avoid keeping the wireless foot control in proximity of other RF sources, such as wireless LAN cards, other radio devices, home RF devices, microwave ovens. The recommended distance is at least 2 metres in the case of microwave ovens and 1 metre in all other cases.
- Even though the electromagnetic field irradiated by the foot control is insignificant, it is advisable NOT to use it in proximity of life support equipment (e.g. pacemakers or heart stimulators) and hearing aids. Before using any electronic device in health facilities, always ascertain that it is compatible with the other equipment present.
- Exclusively use the dental unit to charge the battery of the WIRELESS foot control.
- The internal battery may only be replaced by a qualified technician.

Warnings for first use.

It is advisable to fully charge the foot control battery before using it for the first time.

WIRELESS foot control operation.

The WIRELESS foot control operates in exactly the same way as the wired version, therefore refer to the paragraphs above paying WARNING to the specific model used.

In addition, the WIRELESS foot control has a specific LED (7) that indicates the battery charge and the communication status with the dental unit.

LED (7) indications.

The colour of the LED indicates the battery charge, while the type of flashing indicates the communication status with the dental unit.

Battery charge:

COLOUR	DESCRIPTION (CABLE DISCONNECTED)	DESCRIPTION (CABLE CONNECTED)
GREEN	Battery charge (>75%)	Battery charged
ORANGE	Battery charge (<50%)	Battery charging
RED	Battery needs charging (<25%)	Battery charge error
Off	Battery flat	Dental unit off or foot control fault

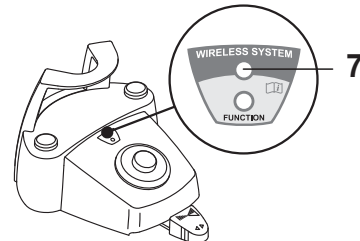

Communication status:

FLASHING	DESCRIPTION
Slow	Connection active in wireless mode
Fast	Connection active with charging cable inserted
Double	Connection search
On fixed	Communication error

Battery characteristics.

The WIRELESS foot control is equipped with a rechargeable Lithium-Polymer battery (Li-Poly, 3.7V, 5200 mAh type Guangzhou Markyn Battery Co. Model 9051109).

NOTE: the exact battery model number might vary at the discretion of the manufacturer.

The battery life is approximately 2 months (estimating 8 hours of consecutive daily operation) with the battery fully charged and fully efficient. The battery efficiency reduces with age. It is estimated that the efficiency is reduced to 60% after 500 complete recharging cycles. Also in this condition, the battery should last about 1 month.

NOTE: when the battery efficiency is so far reduced as to be deemed unsatisfactory to support the daily usage requirements, have it replaced by a qualified technician (original spare part no. 97901336).

WARNING!

Do not attempt to replace the battery yourself.

Limited battery warranty.

The battery in the foot control is covered by a 6-month warranty from the date of installation.

Recharging the battery.

When the batteries in the WIRELESS foot control need to be recharged, operate as follows:

- Open the protective cap of the connector on the rear of the foot control and connect the recharging cable.
- Connect the other end of the recharging cable to the dental unit (see figure).

At this point, the foot control is in the battery charging phase (battery charging warning LED on) even though remaining fully functional.

NOTE: the battery is fully recharged in about 6 hours.

WARNING!

Exclusively use the dental unit to charge the battery of the WIRELESS foot control.

Natural battery discharge.

Should the battery not be used for long periods of time, it may slowly discharge all the same.

After long periods of disuse, it is advisable to always fully charge the battery before use.

Maintenance and disposal

The wireless foot control does not contain parts that can be repaired directly by the user.

In the event of a malfunction, do not attempt to carry out maintenance operations, but directly contact the manufacturer or his local distributor at the numbers indicated in the warranty certificate.

At the end of its lifetime, the battery must be replaced by a specialised technician at a Service Centre.

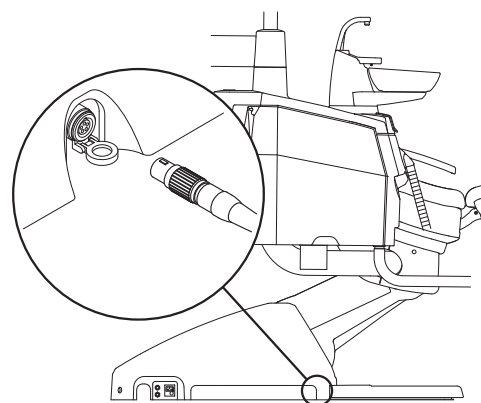
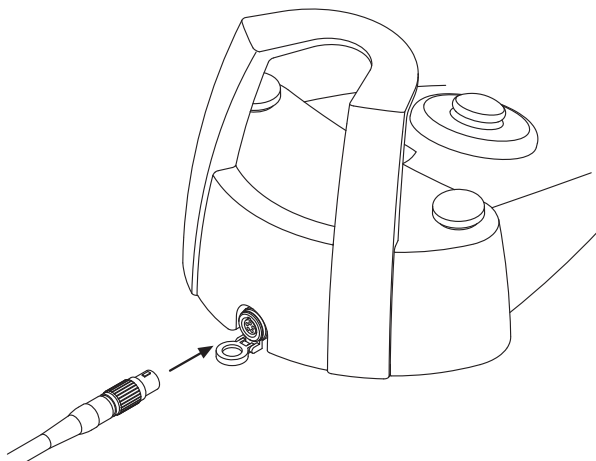

5.3. Syringe

Description of the instrument

- a Nozzle
- b Handpiece
- c Syringe release button
- d Air button
- e Water button
- f Hot/cold selector (only for 6-function syringes)
- g Hot/cold indicator light (only for 6-function syringes)



WARNING!

The instrument is supplied non-sterile.
It is recommended to use single-use protections and nozzles.

Technical characteristics.

- Operating time:
 - 3F syringe: continuous operation,
 - 6F syringe: 5 sec. operation, 10 sec. rest.
- Power supply:
 - 6F syringe (CEFLA models): 24 Vac; 50/60 Hz; 2 A; 50 W.
- Classification in accordance with standard EN 60601-1:
 - 6F syringe (CEFLA models): CLASS II, type B.
- Installation plan: consult the Technical Installation Manual (see Paragraph 11.).

Use.

3-function syringes:

- Place the instrument in its work position.
- Button (e) = water
- Button (d) = air
- Buttons (e + d) = spray

6-function syringes:

- Place the instrument in its work position.
- Operation with hot spray, air and water:
 - Turn the selector switch (f) clockwise (LED g on).
- Operation with cold spray, air and water:
 - Turn the selector switch (f) counter-clockwise (LED g off).
- Button (e) = water
- Button (d) = air
- Buttons (e + d) = spray

Removing the handpiece.

- The nozzle (a) is screwed onto the grip (b).
- 3-function syringes:
Press the button (c) to take the grip off the syringe casing.
- 6-function syringes:
Turn the selector switch counter-clockwise (LED g off) and press the button (c) to take the grip off the syringe casing.

Cleaning

Use soft disposable paper towel dampened with detergents/disinfectants.



WARNING!

- Do not soak the syringe in liquid disinfectants or detergents.
- Products not recommended: harsh products and/or products containing acetone, chlorine and sodium hypochlorites.

Sterilization.

Syringe grip and spout: steam autoclave at 135°C (2 bar) following the instructions for use of the device.



NOTE: bag before sterilizing.

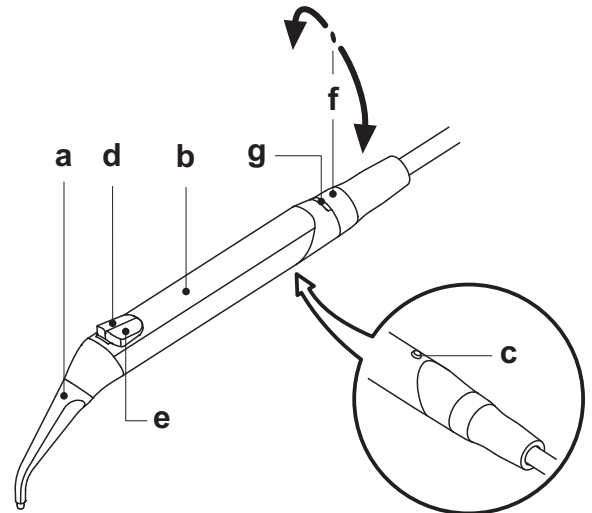

5.4. Turbine

Connecting the handpiece and changing the chuck.

Refer to the specific instructions furnished with the handpiece.

Use.



WARNING!

Read the instructions for use of the various turbines.

• **Operating time: work 5 min., rest 5 min.**

- Place the instrument in its work position.
- Use the foot control pedal to start the instrument (see paragraph 5.2).
- The cock (f), found near the instrument, is used to adjust the amount of water in the spray.
- The cock (e) adjusts the amount of air spray for all the instruments.



NOTE: the turbine cord can also be used to connect the air micro-motors equipped with 4-way connector and conform to ISO 13294 - Dental Air Motor.



WARNING!

The instrument is supplied non-sterile.

Adjusting the turbine's operating speed.

- Place the instrument in its work position.
- Use buttons "INCREASE" or "DECREASE" to set the maximum speed percentage of the turbine.



NOTE: the data set are automatically saved.

- The foot control pedal adjusts the operating speed from the minimum to the maximum values set (see paragraph 5.2).

Turning on the fibre optics

- Place the instrument in its work position.
- Press the button to turn the fibre optics on/off.
Indicator light off: operation without fibre optics.
Indicator light on: operation with fibre optics.



NOTE: the fibre optics shut off when the turbine is not used for 30 seconds (rheostat switch off).

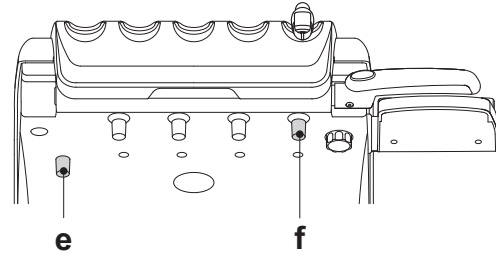

Cleaning and care.

Refer to the specific instructions furnished with the handpiece.

It is recommended to use Daily Oil (CEFLA S.C.) for lubrication.

Sterilization.

Steam autoclave at 135°C (2 bar) following the instructions for use of the device.



WARNING!

Carefully read the operating instructions supplied with the handpiece before attempting to sterilize.

Safety guidelines



WARNING!

- The turbine must never be started without attaching the chuck or false chuck.
- The chuck release button must be held down during operation!
Friction between the button and micromotor rotor overheats the head and may cause burns.
- The patient's internal tissues (tongue, cheeks, lips, etc...) must be protected against contact with the button by using suitable instruments (mirror, etc...).
- The chucks and various instruments attached to the handpieces must comply to the standard ISO 10993.

5.5. Micromotor

Coupling the handpieces and changing the chuck. Refer to the specific instructions furnished with the micromotor and various handpieces.

Use.



WARNING!

Also read the instructions for use of the various motors.

- **Operating time: work 5 min., rest 5 min.**
- Place the instrument in its work position.
- Use the foot control pedal to start the instrument (see paragraph 5.2).
- The cock (f) adjusts the water flow to the spray.
- The cock (e) adjusts the amount of air spray for all the instruments.

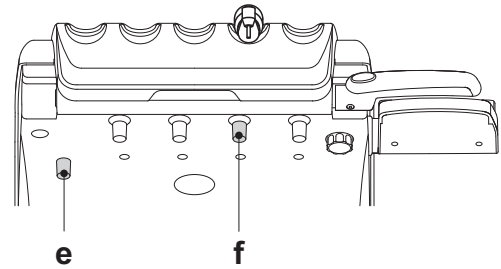

Adjusting the micromotor's operating speed.

- Place the instrument in its work position.
- Use the INCREASE or DECREASE buttons to set the maximum micromotor rotation speed.



NOTE: the data set are automatically saved.

- The foot control pedal adjusts the operating speed from the minimum to the maximum values set (see paragraph 5.2).

40.0



39.5

Selecting the direction of rotation.

- Place the instrument in its work position.
- Press the INVERSION button on the console.

Indicator light off: clockwise rotation.

Indicator light on: counter-clockwise rotation.



WARNING!

When the micromotor is taken out, 3 BEEPS sound to signal counter-clockwise rotation.



NOTE: when the rheostat switch is on, the micromotor cannot reverse.

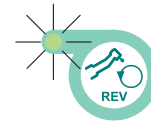

Turning on the fibre optics

- Place the instrument in its work position.
- Press the button to turn the fibre optics on/off.
- Indicator light off: operation without fibre optics.
- Indicator light on: operation with fibre optics.



NOTE: the fibre optics shut off when the micromotor is not used for 30 seconds (rheostat switch off)

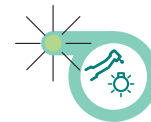

Cleaning and care.

Refer to the specific instructions furnished with the instrument.
It is recommended to use Daily Oil (CEFLA S.C.) for lubrication.



WARNING!

- **Do not soak the syringe in liquid disinfectants or detergents.**
- **Products not recommended: harsh products and/or products containing acetone, chlorine and sodium hypochlorites.**

Sterilization.

Handpieces only: steam autoclave at 135°C (2 bar) following the instructions for use of the device.



WARNING!

Carefully read the operating instructions supplied with the instrument before attempting to sterilize.

Safety guidelines



WARNING!

- **Never put the contra angle on the micromotor while it is running.**
- **The chuck release button must be held down during operation!**
Friction between the button and micromotor rotor overheats the head and may cause burns.
- **The patient's internal tissues (tongue, cheeks, lips, etc...) must be protected against contact with the button by using suitable instruments (mirror, etc...).**
- **The chucks and various instruments attached to the handpieces must comply to the standard ISO 10993.**

5.6. Scaler

Connecting the handpiece and inserts.

Refer to the specific instructions furnished with the handpiece.

WARNING!

Before attempting to connect the handpiece, make certain the contacts are perfectly dry. Blow air from the syringe, if necessary, to dry.

Use.

WARNING!

Also read the specific instructions for use of the various handpieces.

• Operating time:

- U-PZ6 scalers: 5 min. operation, 5 min. rest,
- U-PZ7 scalers: 5 min. operation, 5 min. rest,
- SATELEC scalers: 5 min. operation, 5 min. rest,
- SATELEC LED scalers: continuous operation.

- Place the instrument in its work position.
- Use the foot control pedal to start the instrument (see paragraph 5.2).
- The cock (f) adjusts the cooling water flow.

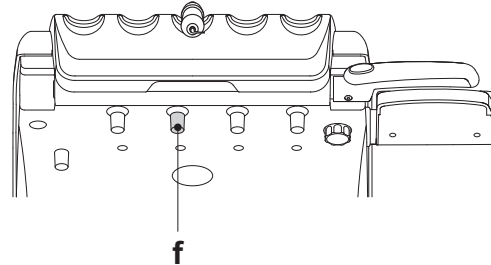

Safety guidelines

WARNING!

- Before attempting to connect the handpiece, make certain the contacts are perfectly dry. Blow air from the syringe, if necessary, to dry.
- Make sure the threaded sections of the inserts and handpiece are perfectly clean.
- Do not change the shape of the inserts.
- Check wear and tear of the inserts on a regular basis, replacing them in the following cases:
 - obvious wear
 - drop in performance
 - out of shape or banged.
- Notes on U-PZ7 descalers:
 - Class 1 LED apparatus;
 - Do not direct the light beam in anyone's eyes when cleaning or servicing the device (it is recommended to keep the fibre optics shut off).

Adjusting the scaler's power output.

- Place the instrument in its work position.
- Use buttons "INCREASE" or "DECREASE" to set the scaler's maximum power percentage.

NOTE: the data set are automatically saved.

- The foot control pedal operates the instrument at the set maximum power (see paragraph 5.2).



ENDO function.

The scaler operates at up to 1/2 of the maximum power set.

- Place the instrument in its work position.
- Press the INVERSION button on the console.
- Indicator light off: regular operation.
- Indicator light on: ENDO function.

NOTE: with the foot control lever activated, you cannot change operation.

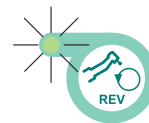

Cleaning and care.

Refer to the specific instructions furnished with the instrument.

WARNING!

- Do not soak the handpiece in liquid disinfectants or detergents.

Sterilization.

- Torque wrench, scaler bits and scaler handpiece: steam autoclave at 135°C (2 bar) following the instructions for use of the device.

WARNING!

Carefully read the operating instructions supplied with the instrument before attempting to sterilize.

Safety standards.

WARNING!

- To avoid hazards or malfunctions when connecting the board, do not reverse the positions of the cords for scalers that are different brands.
- The inserts attached to the handpiece must comply to Biocompatibility standard ISO 10993.

5.7. T LED curing light

Technical specifications.

Supply voltage: 24-36 VDC
 Max. power absorbed: 6 VA
 Light source: 1 5W LED
 Wavelength: 430-490 nm
 Acoustic signals: at cycle start, every 5 seconds, and at cycle end
 Type of operation : intermittent (3 consecutive cycles - 60 sec. rest)
 Programs: 6 (preset)

General description of the light.

- a Light handpiece.
- b Rotary end section.
- c Fibre optic.
- d Eye protection.
- e Power cord.
- f Start button.

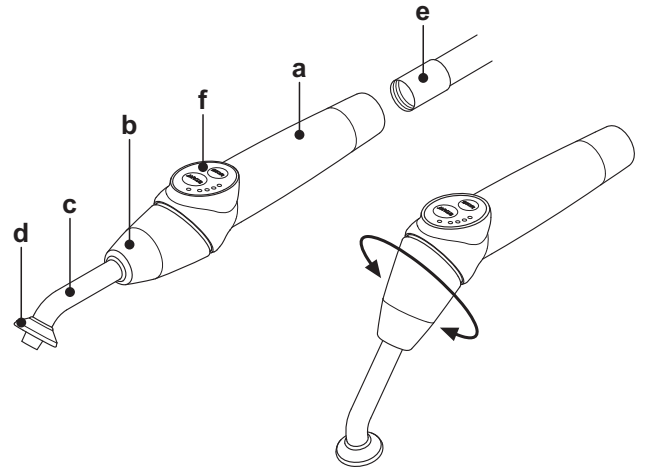

NOTE: the curing light can be used in different configurations (wand, gun or any intermediate position) to aid the user.

NOTE: the curing light is delivered in its original packing which should be kept for future shipment.

Description of the control pad

- [1] **LED 1 (STANDARD cycle) :**
Emission of 1000 mW/cm² for 20 seconds (this cycle is set as default at the time of sale).
- [2] **LED 2 (FAST cycle) :**
Emission of 1600 mW/cm² for 15 seconds.
- [3] **LED 3 (STRONG cycle) :**
Emission of 1800 mW/cm² for 20 seconds.
- [4] **LED S :**
When LED S is on, you access ramp cycle mode and at the same time the LEDs B, R and L next to it come on:
 [LED S + LED 1] **ramp cycle B (BONDING) :**
Ramp cycle with emission of 500 mW/cm² for 5 seconds, ramp from 500 to 1000 mW/cm² for 5 seconds and 1000 mW/cm² for 5 seconds for a total of 15 seconds.
 [LED S + LED 2] **ramp cycle R (RAPID RESTORATION) :**
Ramp cycle with emission of 500 mW/cm² for 5 seconds, ramp from 500 to 2200 mW/cm² for 5 seconds and 2200 mW/cm² for 5 seconds for a total of 15 seconds.
 [LED S + LED 3] **ramp cycle L (LONG RESTORATION) :**
Ramp cycle with emission of 500 mW/cm² for 5 seconds, ramp from 500 to 1800 mW/cm² for 5 seconds and 1800 mW/cm² for 10 seconds for a total of 20 seconds.
- [5] **Malfunction signalling LED :**
This red LED comes on only if there is a malfunction.
- [6] **START button:**
Pressing the START button starts the cycle selected at that moment (the cycle indication LED will come on).
If it is pressed again at any time during the cycle, light beam emission will immediately be interrupted.
- [7] **MODE button :**
This button is used to select the cycle to be run. It allows changing from the cycle you are in at that moment to the immediately following cycle.
The first three cycles (1, 2 and 3) are at constant power and the LEDs come on individually.
When LED S is on, you access ramp cycle mode and at the same time the LEDs B, R and L next to it come on.
Once the LED of the cycle you intend to use has come on, the lamp is ready for use. Pressing the START button, light beam emission is activated according to the cycle selected .

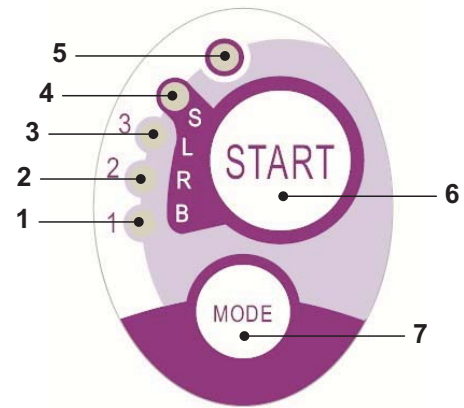

Cycle	LED	Total time	Ø8 mm	Total energy
standard	1	20"	1.000 mW/cm ²	20.000 mJ
fast	2	15"	1.600 mW/cm ²	24.000 mJ
strong	3	20"	1.800 mW/cm ²	36.000 mJ
bonding	S+1	15"	ramp cycle	11.250 mJ
rapid rest	S+2	15"	ramp cycle	20.250 mJ
long rest	S+3	20"	ramp cycle	26.250 mJ

NOTE: the cycle can be selected and the button is operative only when the curing light is not emitting any light. If the button is accidentally pressed while light is being emitted, nothing will happen.

Operation.



WARNING!

The instrument is supplied non-sterile.
 Before use, disinfect the lamp grip. The optical fibre and the eye protection can be sterilized in a steam autoclave at 135°C.

- Put the fibre optic (c) in its housing until it clicks.
- Attach the curing light handpiece to the end of its power cord and tighten the ring (e).

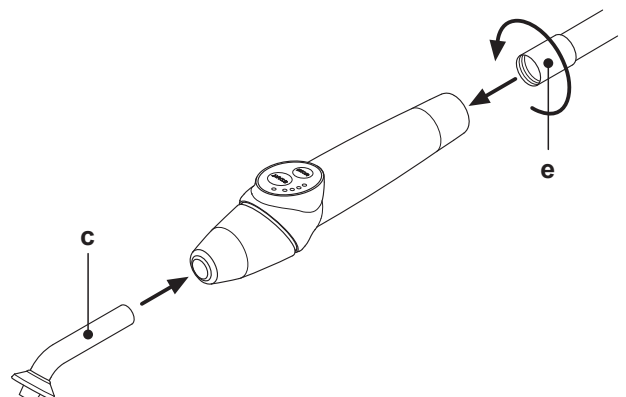

- Take the light out of its housing on the assistant's board or instrument board.

NOTE: One animated symbol will be shown on the console display to confirm that the instrument has been activated.

- Turn the front of the light and/or fibre optic to the position most suitable for curing (wand, gun or intermediate position).
- Use the MODE button to select the desired cycle as previously directed (the selected cycle is always indicated by the illuminated LED).

NOTE: the curing light has a permanent memory therefore the last cycle used will always be present the next time it is used.

- Place the fibre optic in the position required for curing.

NOTE: the fibre optic should be placed as close to the material to be cured as possible without touching it.

- Press button START to start the cycle.



WARNING!

Operation: runs 2 consecutive cycles, rests 60 seconds.

NOTE: when a programmed cycle is activated, the LEDs (1, 2, 3, B, R, L) indicate the time that elapses (in multiples of 5 seconds) and turn off every 5 seconds of operation.

The curing light comes with a beep that BEEPS when the cycle starts, BEEPS every 5 seconds of operation and lastly BEEPS twice at the end of the work cycle.

- Allow light emission to stop by itself. However, it can be stopped at any time by simply pressing the START button again.



WARNING!

- The curing light is equipped with a system that signals malfunctions by illuminating the LEDs in different combinations (see next paragraph).
- The curing light is equipped with a cut-out.

Indicators.

The following indicators are provided on the control console to signal curing light failure:

- **LED 5 and LED 1, green, constantly on.**
Lamp does not emit any light. Contact technical service department.
- **LED 5 and LED 2, green, constantly on.**
Instrument start up controller failure.
Contact technical service department.
- **LED 5 and LED 3, green, constantly on.**
Power supply too low.
Contact technical service department.
- **LED 5 and LED 4 flash continuously.**
Handpiece cut-out tripped. These LEDs will continue to flash until the light has cooled down enough (about 5 minutes) for it to be used again.
If the problems persists, contact the technical service department.

Maximum curable thickness.

The maximum curing thickness with single cycles is 3 millimeters (refer to the instructions of the composite material used as well).



WARNING!

This thickness must not be exceeded as the layer may not be completely cured.

Safety guidelines



WARNING!

- The LED is a Class 2 light source in accordance with IEC 62471. **DO NOT FIX THE BEAM.**
The light emitted may cause eye damage in the event of direct radiation without eye protection.
Eye protection must always be worn when using the curing lamp and do not direct the light beam in eyes.
The light emitted may damage soft tissues (oral cavity mucous, gums, skin).
Be extremely careful to direct the light precisely on the material to be cured.
- **People with eye diseases, such as those who have had cataracts removed or retina diseases must be adequately protected when the curing lamp is used, for example with suitable protective eyewear.**
- **The rotary end can turn 180° counter-clockwise in relation to the handpiece to change over from wand to gun configuration.**
To go back to wand configuration, turn clockwise.
A click is heard when the two positions are reached. Do not turn any more once the click is heard.
The intermediate positions can be used even if a click is not heard.
Put the fibre optic back into the correct position after turning the end section.
- **Do not pull the power cord.**
- **Do not expose the handpiece to excessive vibrations.**
- **Do not drop the handpiece and in particular the fibre optic. The lamp may break if accidentally banged.**
Check the condition of the handpiece if it has been banged or dropped before using the curing light. Try to turn on the light and check operation first without using it on the patient.
If cracked, broken or if there are any other faults, do not use the curing light on the patient and contact the technical service department.

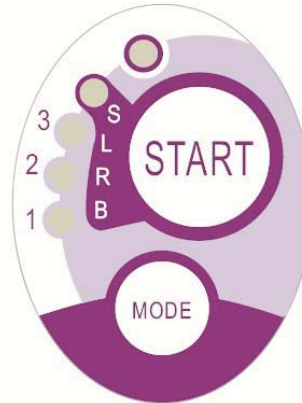

The fibre optic is rather delicate and may crack or break if banged, affecting the final amount of light emitted. If dropped, carefully inspect the fibre optic to verify if it is cracked or broken. If cracked, a strong light appears in the spot in which the fibre is cracked. In all these cases, the fibre optic must be replaced.

- **The curing light handpiece (sold separately) can be connected only to dental units with connections for this curing lamp. Connection to any other equipment may damage the circuits inside the lamp and seriously injure the user and patient.**
- **The curing lamp handpiece is not protected against liquid penetration (IP20).**
- **The curing lamp handpiece is not suitable for use in the presence of flammable anaesthetic gas mixed with air, oxygen or nitrous oxide (N₂O).**

Cleaning

The curing lamp may be a vehicle for cross contamination between patients. The most contaminated parts are the fibre optic and eye protection. Before sterilizing them, make sure there are no residues of curing products: if necessary, clean with alcohol or a plastic spatula. Exclusively sterilize the optical fibre and the eye protection in an autoclave at a sterilization temperature of at least 134°C.



WARNING!

- **The fibre optic is able to support 500 autoclave cycles after which it tends to become opaque and therefore emit less light.**
- **The eye protection must also be replaced after 500 cycles.**
- **Contact the manufacturer to purchase original spare parts (fibre optic + eye protection: code 97660404).**

The handpiece cannot be put in autoclave; disinfect it on the outside with suitable products and cover it with disposable plastic wrap. Use soft disposable paper towels to disinfect the handpiece. Do not use harsh products or soak in liquids.



WARNING!

- **The curing light handpiece is NOT suitable for autoclave.**
- **The curing light handpiece is not protected against penetration of liquids therefore it CANNOT be soaked in solution to be sterilized.**
- **The outside of the lamp should be disinfected with the fibre optic on. Do not use any type of disinfectant on the exposed optical surface of the handpiece when the fibre is removed. The surface will become irreparably opaque if it comes into contact with disinfectant.**

Maintenance

This equipment does not require any particular type of maintenance. Only technicians authorized by the manufacturer can replace and/or repair the handpiece and dental unit. The handpiece has been purposely constructed in a manner that requires specific tools to open it and therefore it cannot be removed by the user. The warranty is automatically void if the handpiece is altered in any way.

Troubleshooting

- **When the lamp is removed, the light does not come on (no leds on control console illuminated).**

Make sure the Midwest connection is correctly attached to the power cord.

Carefully screw the ring, try to turn on the lamp and then take it off again.

If the problem persists, contact the technical service department.

- **Less light emitted**

- Make certain the fibre optic is not cracked or damaged in any way: replace it if it is.

Contact the manufacturer to purchase original spare parts.

- Make sure there are no residues of curing products on the end of the fibre optic: if necessary, wipe off with alcohol or a plastic spatula.

If the handpiece has to be sent back, please disinfect it.

Ship it back in its original packing.

In addition, please enclose a description of the fault with the shipping note.

Disposal at end of service life

- Never throw out the equipment in regular trash.
- Observe current local regulations regarding disposal of the equipment at the end of its service life.
- Due to the possibility of cross contamination, disinfect the equipment before disposing.

5.8. C-U2 dental camera

The C-U2 dental camera system, complete with an extremely lightweight ergonomic handpiece, is specially designed for simple and well-conceived usability in examining the oral cavity. Auto-exposure and fixed focus features provide easy operation. This system is designed to allow the dentist to more efficiently show and explain to patients all oral conditions and reasons for planned treatment. The C-U2 system allows filming and taking high-definition (1280x720) live images of the section in question to be taken through a touch of a fingertip on the touch-sensitive area of the handpiece. The live intraoral images are displayed on the monitor or Personal Computer.

WARNING!

The camera may be used as a tool to aid in diagnosis however, the result must always be compared to visual examination and/or other diagnostic indications. Evaluations and conclusions based only on the image taken by the camera may be poor as the colors and shapes, electronically processed, may not perfectly correspond to the actual ones.

Safety guidelines.

WARNING!

- The external PC and the external monitor must be of medical grade, namely they have to be certified and comply with the standard IEC 60601-1 3rd Ed. They have to be able to ensure a double insulation level for both patient (2 MOPP) and operator (2 MOOP):
 - with respect to the power mains;
 - to all the I/O ports (USB, LAN) supplied with Safety Extra Low Voltage (SELV).
- Even though the electromagnetic field irradiated by the device is insignificant, it is advisable not to use it in proximity of life support equipment (e.g. pacemakers or heart stimulators) according to the specifications included in the user manual of such equipment.
- The disposable infection control sheaths must be used with the device. Change the sheath for each new patient.
- After putting on a new disposable infection control sheath, check it over before using the camera, making sure it is not torn anywhere. If it is, take it off and put on a new one.
- Do not place the handpiece in liquids or in autoclave under any circumstances.
- Store the handpiece in a clean dry area.
- Do not bend the connecting cable excessively.
- Be extremely careful not to drop the handpiece and do not expose it to excessive vibrations.
- Never use a damaged handpiece. Make sure the camera is in good condition and has no sharp edges before attempting to use it. If in doubt, do not use the handpiece, carefully put it away, and contact technical assistance.
- Before starting the equipment, check the condition of the lens protection.
- Do not aim the light beam at the operator's or patient's eyes during operation.
- During continuous use (example, more than 10 consecutive minutes), the temperature of the camera's tip usually increases significantly; if this is uncomfortable, put the handpiece in its holder for a few minutes to allow the light source to cool down. When the camera needs to be used for a prolonged time, reduce light brightness.
- If left running for extended periods, make sure the temperature of the tip is acceptable before attempting to use the camera. Briefly touch the clear plastic part with your fingertip being careful not to touch the lens in the middle.
- Do not attempt to bend, pull or remove the handpiece.

Connecting the handpiece.

Attach the handpiece of camera C-U2 (**a**) to the end of the cord and tighten the ring nut (**b**).

WARNING!

Make sure the cord is firmly screwed onto the handpiece.

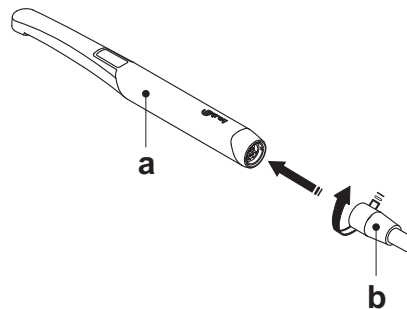

Use of the camera

Place the handpiece in its work position; the light comes on and the camera is in the last LIVE mode used.

NOTE: Two animated symbols will be shown on the console display to confirm that the instrument has been activated.



• **MIRROR function**

With the camera set to LIVE mode, briefly press the "Reverse" button present on the console to change from viewing real images to mirror images.

• **FREEZE function.**

Handpiece C-U2 is equipped with a touch-sensitive button (**g**). Tap this button or actuate the foot control to freeze the image of interest. Tap this button again (or actuate the foot control) to unlock the frozen image.

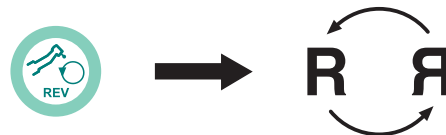

• **Selecting the single image or multi-image operating mode**

With the camera set to LIVE mode, hold down the "Reverse" button present on the console to change from viewing a single image to multi-images (and vice versa).

NOTE: an icon (**1**) found in the top right-hand corner signals when this mode has been selected.

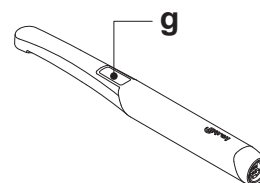

• Operation in single image mode

The "live" image appears on the monitor when the camera is set to LIVE and single image mode.

Press the touch key (**g**) on the handpiece (or actuate the foot control) to freeze the image, which is immediately displayed on the monitor, canceling the previous image.

NOTE: the last image frozen remains on the monitor even if the camera is put back in place.

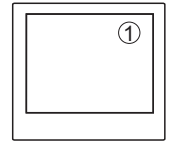

• Operation in multi- image mode

The "live" image appears on the monitor and an icon (1) is shown in the top right-hand corner when the camera is set to LIVE and multi-image mode.

When the camera is set to FREEZE, hold down (at least 2 seconds) the left foot control button to select the 4 saved images one after the other.

When the camera is set to FREEZE, hold down the right foot control button to select/deselect the full screen view of the selected image.

NOTE: the frozen image appears directly on the monitor in the first box available (e.g. 1) on the page currently displayed. Each subsequent frozen image is placed in the next box, turning clockwise. Once the 4 boxes available are full, the next frozen images will replace the existing ones, going clockwise.

NOTE: press the MEMORY button for 3 seconds to delete all 4 images on the page displayed.

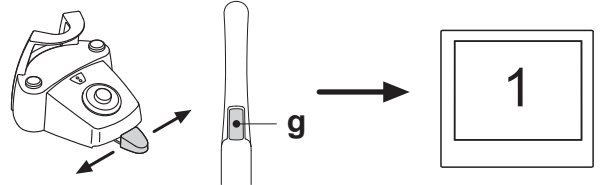

• VIEW function.

With the camera set to LIVE mode, hold down (at least 2 seconds) the right foot control button to view the images previously frozen.

Hold down the left foot control button to select the 4 saved images one after the other.

On the other hand, hold down the right foot control button to select/deselect the full screen view of the selected image.

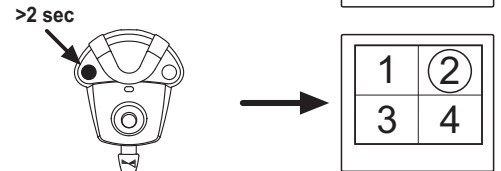

• Handpiece status.

AAAn optical guide, illuminated by a multicolour LED indicator, found in the area near the control button (**g**), shows handpiece status as per the table given below:

Color	Situation
Blue light flashes, very slowly	Handpiece in standby
Light blue steady light	Handpiece activated, live images displayed
Blue/ light blue flashing light	Handpiece in image freeze mode
Brief red flashes	Internal error: contact Customer Service

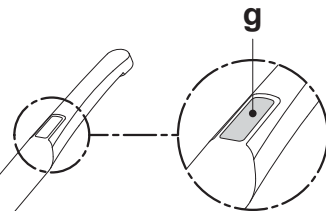
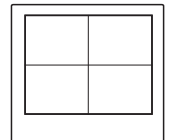

MyRay iCapture

This program allows the C-U2 camera to be set up when it is connected to a PC/WORKSTATION.

For a full description on how the MyRay iCapture program works, refer to the instructions, in electronic format, supplied with the C-U2 handpiece.

Disposable infection control sheaths

The camera can be a source of cross-contamination between patients. For this reason always use it with a disposable infection control sheath (code 97901590) and disinfect it on the outside after use everyday. The sheath (with white paper backing) is enclosed in two protective layers: a transparent one with blue tab at the front and a paper one at the back. Follow the directions below to install a new infection control sheath:

1. Insert the camera handpiece tip between the layer with White tab and the rear paper backing. The lens, surrounded by the LEDS, must face down, towards the rear paper layer.
Gently push the handpiece to the end of the sheath.
2. Pull the blue tab removing the protective covers.
3. The dental camera is now protected and ready for use.



WARNING!

- Always make certain the handpiece is correctly inserted inside the infection control sheath.
- Always change the disposable infection control sheath before using the device on a new patient. This is a fundamental step in preventing cross-contamination.
- Disposal: the disposable infection control sheaths are to be treated as special waste materials (like surgical gloves).

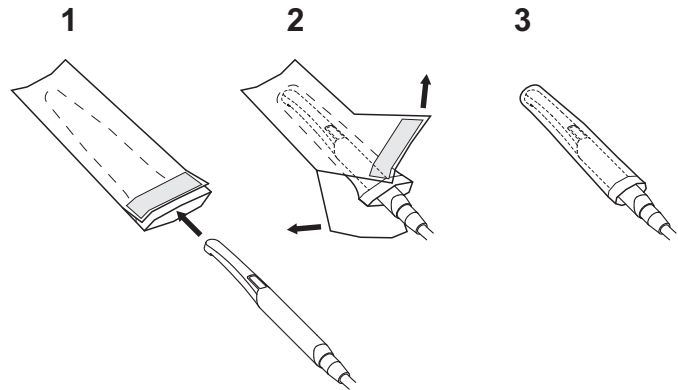

Cleaning and disinfecting.

Clean the handpiece with a suitable product after each use: refer to Paragraph 1.4.

WARNING!

- The intraoral camera is not designed for cold sterilization by being soaked, for example in solutions such as glutaraldehyde or hydrogen peroxide.
- All products must be used as directed by the manufacturer.
- All material used to clean and disinfect must be thrown away.

Maintenance and repairs.

The C-U2 camera system does not require any particular maintenance. In the event of malfunctions, please send back the complete handpiece.

WARNING!

There are no parts that can be repaired on site. In the event of a malfunction, please contact an authorized dealer.

Returning parts.

- Please send back any defective devices in their original packaging. Do not reuse damaged boxes.
- The device must be disinfected before being shipped to prevent cross-contamination. Handpieces that have not been adequately cleaned and disinfected will not be accepted.

WARNING!

The sender shall be held responsible for any equipment damaged incurred during shipment regardless of whether or not the devices are under warranty.

5.9. ZEN-Xi integrated sensor

Integrated sensor ZEN-Xi is a medical device employed to acquire intraoral x-rays in an electronic format with a Personal Computer interface device. When used together with dental practice management software, the x-ray pictures can be saved in the patient's folder and viewed on the desktop pc monitor at a later time.



WARNING!

Do not use the system for any other purpose different from acquisition of intraoral x-rays and do not use it if you are not a professional in the dental and radiology fields.

Use.

Use and care instructions for integrated sensor ZEN-Xi are enclosed with the apparatus.



NOTE: integrated sensor ZEN-Xi does not interact with the dental unit from an electric point of view.

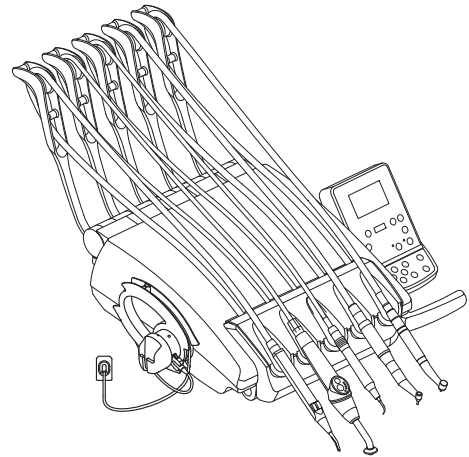

6. Assistant's board operation

1

"Pro02" assistant's board.

Main features:

- Two articulated arms (c) secure the board (a) to the hydrogroup (b) allowing it to be placed in the most convenient work position.
- The assistant's board (a) comes with a control console (d) with buttons used to operate the dental chair and hydrogroup.
- The assistant's board can be equipped with 2 suction tubes and 2 instruments.
- The assistant's board comes with sliding rollers (f) that guide and hold up the suction tubes.



NOTE: the assistant's board is equipped with a safety device that locks out dental chair movement when the board itself is pushed upwards.

1

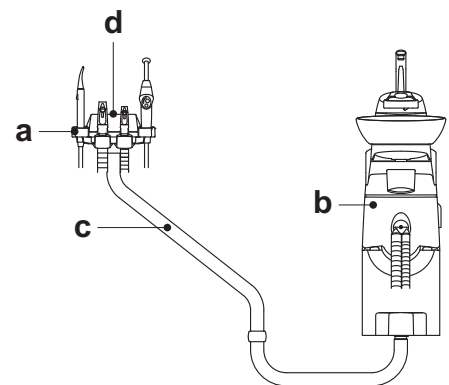

2

"Pro01" assistant's board.

Main features:

- A single articulated arm (e) secures the board (a) to the hydrogroup (b) allowing for movement within a wide range of action.
- The assistant's board comes with a control console (d) with buttons used to operate the dental chair and hydrogroup.
- The assistant's board can be equipped with 2 suction tubes and 2 instruments.
- The assistant's board comes with sliding rollers (f) that guide and hold up the suction tubes.



NOTE: the assistant's board is equipped with a safety device that locks out dental chair movement when the board itself is pushed upwards.

2

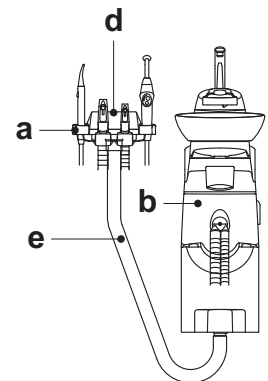

Cleaning the sliding rollers.





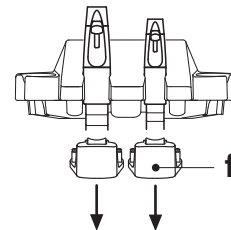



Push down and take off the sliding rollers (f).

Clean the sliding rollers using a suitable product: refer to Paragraph 1.4.



6.1. Assistant's touchpad

Description of the buttons:

-  Water to bowl button.
-  Water to cup button.
-  Operating lamp on/off button.
-  Home position recall button.
-  Rinsing position recall button.
-  Chair seat up button.
-  Chair back up button.
-  Chair seat down button.
-  Chair back down button.

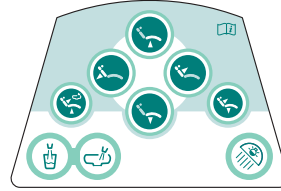

6.2. Syringe on assistant's board

For detailed information regarding operation of this instrument see paragraph 5.3.

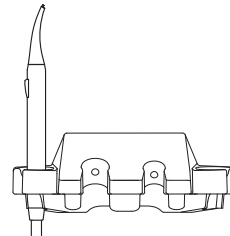

6.3. Curing lamp on assistant's board

For detailed information regarding operation of this instrument see paragraph 5.7.

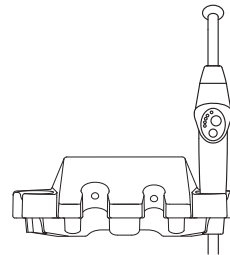

6.4. Intraoral camera system on assistant's board

For detailed information regarding operation of this instrument see paragraph 5.8.

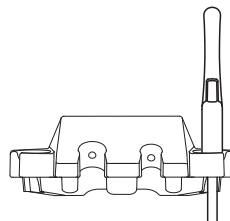

6.5. Suction tubes

Suction starts by taking the tube off the board. To adjust suction, use the slider (a) located on the tube handpiece.

NOTE: when the tube is put back in place, suction stops approximately 2 seconds later. This is done to dry the suction tubes.

Removing the suction tubes.



WARNING!

Always wear gloves to prevent contact with infected material when removing the suction tubes.

Remove the suction tubes from the conveyor fittings by turning and twisting the tube fitting. Detach the suction tubes from the holders by turning and twisting the tube fitting.



WARNING!

Never directly grasp the suction tube.

Cleaning the suction tubes.

As the dental units may be equipped with different suction systems (liquid ring or wet, air) carefully follow the instructions provided by the suction system manufacturer when disinfecting the system regarding the product to be used, times and directions for use.



WARNING!

For cleaning of the suction system, it is recommended to use STER 3 PLUS (CEFLA S.C.) diluted in a 6% solution (equivalent to 60 ml of product in 1 litre of water).

Disinfection.

- Cannula holder terminals: steam aut
- Suction tubes: soak to cold sterilize.



WARNING!

Never use procedures in which the temperature goes over 55 °C with the tubes.

Maintenance.

Periodically lubricate the O-rings of the cannula holder terminals (see Paragraph 9.4.) using **S1-Protective Lubricant for O-Rings** (CEFLA S.C.).

Note about biocompatibility.

Only suction tubes supplied with the dental unit and there after original replacement tubes can be used. The suction tubes must comply to the standard ISO 10993.

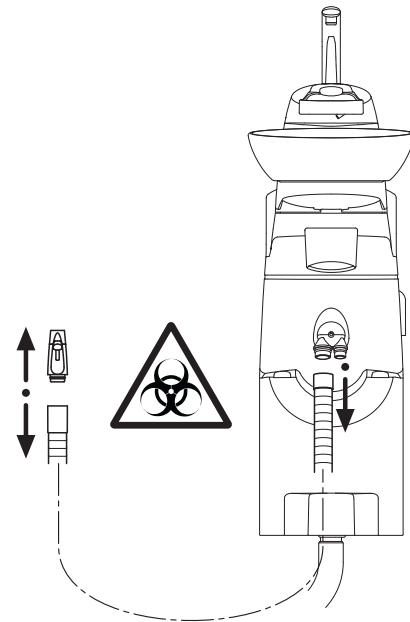
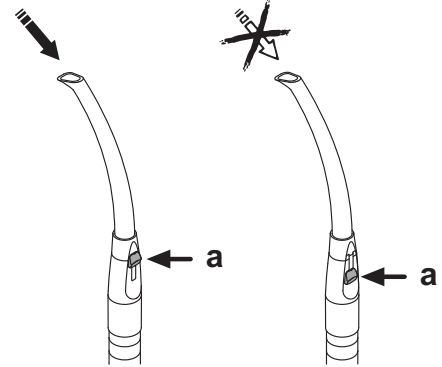
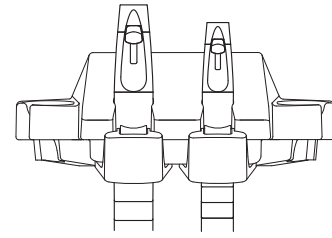

6.6. Hydraulic saliva ejector

The hydraulic saliva ejector starts running When the tube is removed from the support.

Cleaning after each use.

Aspirate about ½ litre of STER 3 PLUS (CEFLA S.C.) diluted in a 6% solution (equivalent to 60 ml of product in 1 litre of water).

Cleaning the saliva ejector filter.

This operation must be carried out at the end of each work day.



WARNING!

Put on gloves before attempting to perform this operation!

- Aspirate about ½ litre of STER 3 PLUS diluted in a 6% solution (equivalent to 60 ml of product in 1 litre of water).
- In order to prevent possible dripping of liquids and secretions from the filter (**b**) to be extracted, aspirate only air for about 5 seconds.
- Take off the cap (**a**) by turning and twisting at the same time.
- Remove the filter (**b**).
- Clean/replace the filter (code 97290060).
- Put the filter and cap back in place.

NOTE: to prevent liquids and matter from dripping from the filter taken out, suck air only for approximately 5 seconds before performing these operations.

Routine maintenance.

Lubricate the o-rings (**c**) with **S1 – Protection for o-rings lubricant**.

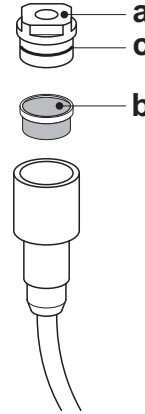
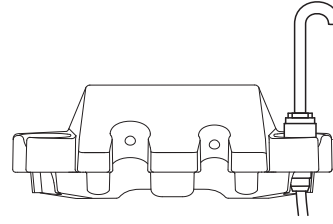

7. Hydrogroup operation

7.1. Fill cup and bowl

The bowl can be turned 160° on the hydrogroup by hand.
The water to cup spout can be removed to ease cleaning.

Control buttons.



Water to bowl.



Water to cup.

Bowl flushing automatically stops after 30 seconds.

Bowl flushing automatically starts in the following cases:

- When the "rinse position" button is pressed;
- When the "water to cup" button is pressed.

Hot water to cup.

When this function is provided, hot water is always delivered to the cup.

Adjusting the amount of water used to fill the cup.

- Turn on the operating unit holding down the Cup Water Delivery button on the assistant's board.



NOTE: an intermittent BEEP signals saving is in progress.

- Press the water to cup key once to start filling the cup.
 - Once the desired water level has been reached, press the water to cup button again making sure the BEEP stops:
- At this point, the new water level in the cup has been saved.

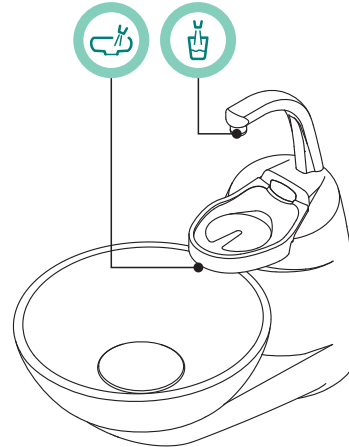

Changing bowl operation

Water delivery to the bowl can take place in an untimed manner (on/off operation with the relative button).

This modification is made by turning on the operating unit holding down the Bowl Water Delivery button on the assistant's board.

A beep sounds to signal the selected operating mode:

- 1 BEEP: timed operation.
- 3 BEEPS: ON/OFF operation.



NOTE: *timed operation is factory set.*



Changing the water to bowl controller with water delivered to cup.

The controller that delivers water to the bowl when the "water to cup" button is pressed can be enabled/disabled.

This modification is made by turning on the operating unit simultaneously holding down the Cup Water Delivery and Bowl Water Delivery buttons on the assistant's board.

A beep sounds to signal the selected operating mode:

- 1 BEEP: controller enabled.
- 3 BEEPS: controller disabled.



NOTE: *the controller is enabled by default.*



Water to bowl controller modification with retrieval of dental chair "Rinse position".

The controller that delivers water to the bowl when the dental chair "Rinse position" button is pressed can be turned on/off.

This modification is made by turning on the operating unit simultaneously holding down the dental chair Rinsing Position and Bowl Water Delivery buttons on the assistant's board.

A beep sounds to signal the selected operating mode:

- 1 BEEP: controller enabled.
- 3 BEEPS: controller disabled.



NOTE: *the controller is enabled by default.*



Water to bowl controller modification with retrieval of dental chair "Automatic return".

The controller that delivers water to the bowl when the dental chair "Automatic return" button is pressed can be turned on/off.

This modification is made by turning on the operating unit simultaneously holding down the dental chair Automatic Return and Bowl Water Delivery buttons on the assistant's board.

A beep sounds to signal the selected operating mode:

- 1 BEEP: controller enabled.
- 2 BEEPS: controller disabled.



NOTE: *the controller is enabled by default.*



Taking off the bowl filter and rinse spout.

- Pull up the spout (**l**) and take it off.
- Pull up the filter (**q**) and its cover (**p**) to remove them.
- Turn the bowl (**m**) counter-clockwise to release it and then pull it up to take it out.

Disinfecting and cleaning.



WARNING!

Always wear gloves to prevent contact with infected material when cleaning the bowl and bowl filter.

The parts are to be cleaned daily at the end of each work day.

- Ceramic spouts and bowl: thoroughly wash with a specially formulated cleaner (for example MD 550 Orotol DÜRR).
- Bowl filter: clean with running water and commercially-available cleaning products.



WARNING!

Do not use acids or harsh products.

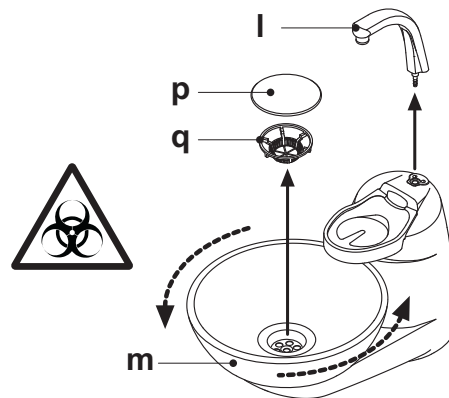

7.2. S.H.S. system (Simplified Hygienization System)

Description of the system.

The system is equipped with a tank (a) suitable for distilled water.
The tank can hold 1.8 liters.

The tank feeds:

- The sprays of all the instruments found on the instrument and assistant's board,
- To fill the cup,
- Water quick-connect coupler (if present).

A by-pass toggle (b) is used to shut off the system if municipal water is to be delivered to the instruments.

This system allows a disinfecting cycle to be performed for the instruments' spray ducts using hydrogen peroxide (see paragraph 7.4.).

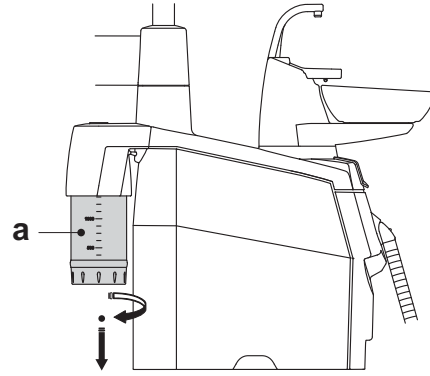

! WARNING!

Perform a disinfecting cycle at the end of each work day.

Filling the tank.

When the water level in the tank is low (about 500 cc), fill it as directed below:

- Turn the switch (c) to "CLOSE AIR PRESSURE".
- Turn the tank counter-clockwise and remove the tank (a).

NOTE: while this operation is being performed, the pressurised air in the tank is automatically released outside.

- Pour distilled water into the tank until the maximum level is reached.

! WARNING!

Use only distilled water. For a higher guarantee of hygiene you can add 600 parts per million of hydrogen peroxide using 20 ml of Peroxy Ag+ per litre of distilled water, or oxygenated water (20 ml of 3% oxygenated water per litre of distilled water).

- Put the tank back in place turning it clockwise.
- Turn the toggle (c) to position "OPEN AIR PRESSURE".

! WARNING!

- **Assure the tank is firmly secured in place before switching the toggle (c) to position "OPEN AIR PRESSURE".**
- **In case of long absences from the studio (holidays), completely empty out the tank (a) before leaving.**

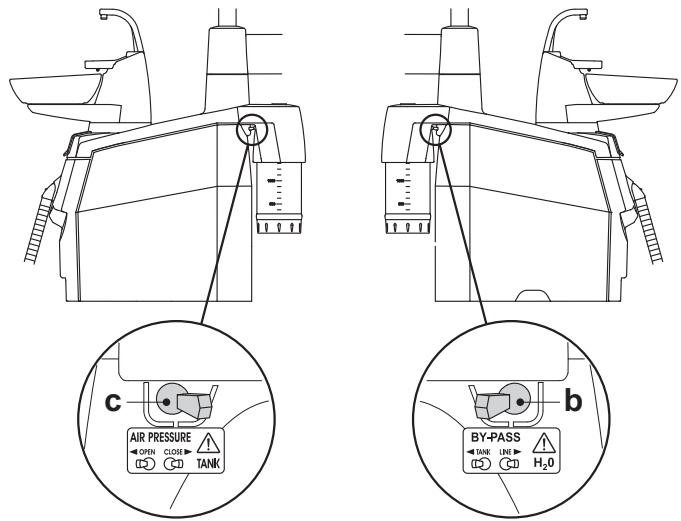

BY-PASS function

The system can be shut off if municipal water is to be delivered to the instruments.

This function is obtained by switching the lever (b) to position "LINE".
Turn the toggle (b) to position "TANK" to go back to working with distilled water.

Cleaning the tank.

It is advisable to periodically (at least once a month) cold-disinfect only the tank using Peroxy Ag+ or 3% oxygenated water (10 volumes) not diluted and operating as follows:

- take the tank out of the dental unit and empty it,
- fill the tank with disinfectant liquid up to the rim,
- leave the disinfectant liquid to dwell in the tank for at least 10 minutes,
- completely empty out the tank,
- rinse the tank with distilled water,
- fill the tank with distilled water and, if necessary, add hydrogen peroxide or oxygenated water as described above,
- put the tank back in place in the dental unit.

7.3. WHE (Water Hygienization Equipment) system

The WHE system assures safe separation (physically) of the dental unit water supply system from the public water mains thanks to a water free-fall section (in compliance with EN 1717).

In addition, the system continuously injects hydrogen peroxide into the water circuit with a final concentration of 0.06% (600 ppm) in the ducts, suitable for bacteriostasis.

To this end, it is recommended to use **PEROXY Ag+** (CEFLA S.C.); nevertheless, 3% oxygenated water may also be used%.

Description of the system.

The W.H.E. system is located in the connection box and is always active. The system is also equipped with a tank (**a**) located in the hydro unit with a capacity of about 500 cc of oxygenated water.

The W.H.E. system automatically deactivates upon activation of the distilled water delivery (if present).

Signaling the hydrogen peroxide level is low.

When the hydrogen peroxide in the tank (**a**) is about to run out, the operatory emits 4 BEEP repeated whenever the equipment is turned on.



WARNING!

Should the disinfectant liquid run out, the operating unit will remain operational but will use mains and NOT treated water.

It is advisable to as soon as possible top up the disinfectant tank.

Filling the tank containing disinfectant liquid.

When the disinfectant liquid in the tank runs out, operate as follows:

- Remove the tank closing cap (**b**) lifting it upwards.
- Pour the disinfectant liquid into the tank (**a**) until it is full.
- Refit the cap (**b**).



WARNING!

Fill the tank only with pure PEROXY Ag+ or 3% oxygenated water (10 volumes) without diluting.

Errors

If the system detects a malfunction, 2 BEEPS are provided. The system shuts down and the operatory unit does not deliver water.

In these cases, first of all verify water and air are correctly supplied to the operatory unit.

Shut off and then turn the operatory unit back on; if the shutdown persists, call technical support.

PEROXY Ag+ storage.

For proper storage of **PEROXY Ag+** follow the manufacturer's instructions printed on the package.

It is important to keep the package tightly closed and store it in a cool place at a temperature not exceeding 25°C.



WARNING!

Never leave PEROXY Ag+ or oxygenated water in the tank (**a) for longer than one month.**

If you are going to be absent from the surgery for long periods of time (holidays), completely empty out the tank (**a) before leaving.**

W.H.E. system tank emptying.

This function permits the W.H.E. system's water circuit to be drained, if the dental unit is going to be left off for several days.

Proceed as directed below:

- Place the container provided under the cup spout and start emptying the water circuit by holding down key "Water delivery to cup" for at least 5 seconds.
- Wait until the water circuit is empty, 5 BEEPS signal when the operation has been completed.
- The operatory unit can now be shut off.



NOTE: When turning back on, the WHE system will automatically reset.

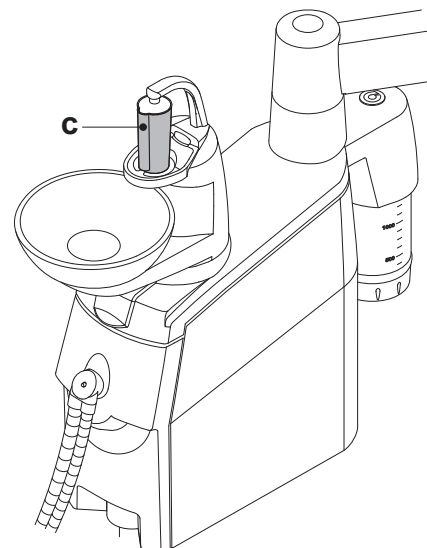
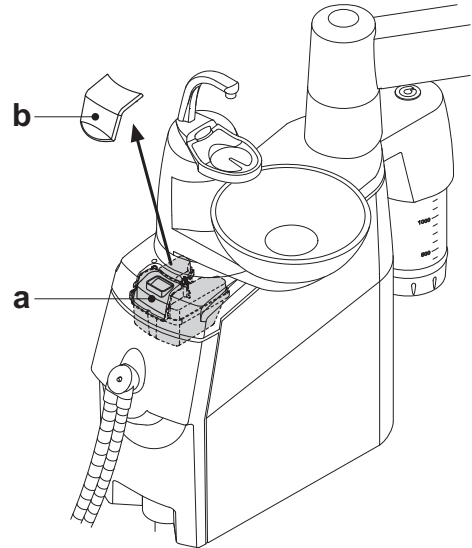

>5 sec

7.4. Disinfection cycle with oxygenated water (manual BIOSTER cycle)

With the S.H.S. system, you can execute a manual disinfection cycle of the water ducts of all the instruments on the dentist's instrument board and the syringe on the assistant's board using oxygenated water (hydrogen peroxide).

To disinfect, proceed as directed below:

A) Prepare the disinfectant:

- Pour undiluted PEROXY Ag+ (or 3% oxygenated water) into the tank marked with an orange band.

NOTE: make sure that the tank is completely filled.

B) Putting in the disinfectant:

- Make sure the spray cocks (**d**) found towards the bottom of the board, are open (if they are not, either very little or no water at all will flow out).
 - Take out the bottle of distilled water (**a**) turning it clockwise.
 - Replace the bottle of distilled water (**a**) with the one containing **PE-ROXY Ag+**.
 - Remove the syringe and empty the duct with the water button.
- NOTE:** when emptying is complete, no water will come out of the duct.
- Repeat the same procedure for the syringe on the assistant's board (with the water key). Use the Water clean system with the foot control for the remaining dynamic instruments (see paragraph 5.2).
 - Turn the toggle (**c**) to position "OPEN AIR PRESSURE".
 - Remove the instruments and fill the ducts with the hydrogen peroxide solution. Use the Water clean system with the foot control for the dynamic instruments and the water button for the syringes.

NOTE: allow the hydrogen peroxide solution to flow out of the instruments 6-7 seconds.

- Put the instruments back in place.

NOTE: at this point, the ducts contain hydrogen peroxide.

C) Disinfectant contact time:

WARNING!
PEROXY Ag+ must be left to dwell in the ducts for at least 10 minutes, but not more than 30 minutes.

D) Rinsing the ducts:

- Turn the toggle (**c**) to position "CLOSE AIR PRESSURE".
- Take out the bottle of hydrogen peroxide (**a**) turning it clockwise.
- Put in the bottle containing distilled water.
- Remove the syringe and empty the water duct.

NOTE: when emptying is complete, no water will come out of the duct.

- Repeat the same procedure to drain the hydrogen peroxide from the ducts for the various instruments.
- Turn the toggle (**c**) to position "OPEN AIR PRESSURE".
- Remove the instruments and wait for distilled water to flow out. Use the Water clean system (see paragraph 5.2) with the foot control for the dynamic instruments and the water button for the syringes.

NOTE: allow water to flow out approximately 6-7 seconds.

- At this point, the ducts contain distilled water again and the dental unit is ready to be used.

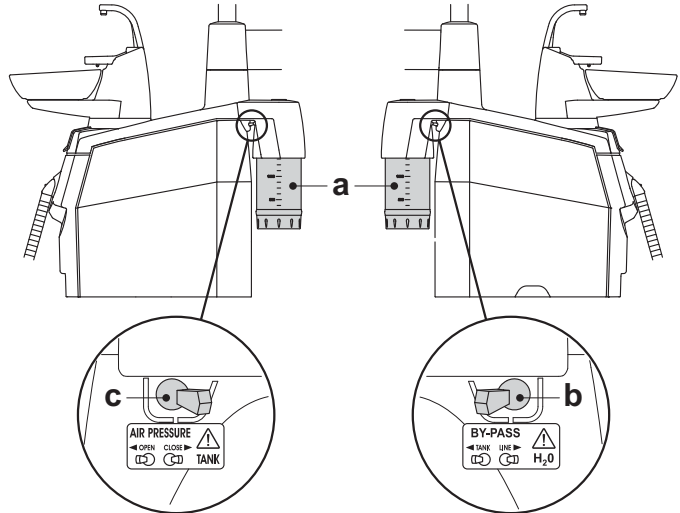
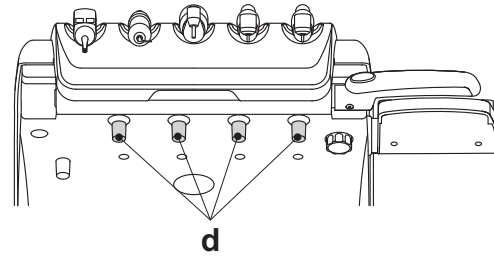

WARNING!

- After disinfection, make sure that you close the tank containing PEROXY Ag+ (it will lose effectiveness if exposed to air).
- It is good practice to perform a disinfection cycle at least once a day, preferably at the end of the day.

PEROXY Ag+ storage.

For proper storage of PEROXY Ag+ follow the manufacturer's instructions printed on the package. It is important to keep the package tightly closed and store it in a cool place at a temperature not exceeding 25°C.

WARNING!

Never leave PEROXY Ag+ or oxygenated water in the tank marked with an orange band for more than one month. In case of long absences from the studio (holidays), completely empty out the tank marked with an orange band before leaving.

7.5. Automatic tool flushing cycle (FLUSHING)

Description of the system.

The FLUSHING automatic cycle allows to carry out an automatic cycle of flushing to renew water present in the water ducts of the instruments on the dentist's and the assistant's instrument board.

Flushing may be carried out with mains water, treated water (if the WHE system is present) or distilled water (if the SHS system is present)

The cycle time is about 2 minutes.



WARNING!

It is advisable to carry out a FLUSHING cycle at the beginning of each working day and between two patients.

FLUSHING cycle setting.

- If the S.H.S. system is present and you want to execute the flushing cycle with distilled water, check that the lever (**b**) is on the TANK position.

NOTE: it is advisable to execute the flushing cycle with a full tank (**a**).

- Press the button on the dentist's console to access the FLUSHING mode.

NOTE: Three animated symbols will be shown on the console display to confirm that FLUSHING mode has been activated.

- Check that the spray taps (**d**) in the lower part of the dentist's instrument board are open (if not, no or too little water will come out).
- Position the container (**e**) for the instruments to be disinfected on the bowl.
- Insert the tubings of the instruments to be disinfected in the container.



WARNING!

For the syringe instrument you need to use the special adapter (**f**) and the heating system must be off.

The micromotor tubing must be completely inserted into the motor body.

NOTE: the syringe is always active, therefore as soon as it is inserted in the instrument container it will immediately start delivering water.

Execution of the FLUSHING cycle.

- Start the flushing cycle by pressing the button on the dentist's console a second time.

NOTE: the time remaining to the end of the flushing cycle is shown on the console display.

- At the end of the FLUSHING cycle (the value 0 is shown on the display), the LEDs of the FIBRE OPTICS and INVERSION buttons start flashing.
- At this point, put the instruments extracted back into place to return to the working condition.

Interruption of the FLUSHING cycle.

Once the flushing cycle has been started, it CANNOT be interrupted.

Error signalling.

Signalling: 2 beeps when you attempt to start the flushing cycle.

Cause: No instrument extracted or instruments not equipped with water ducts extracted.

Remedy: Check the instruments extracted and then start the flushing cycle.

NOTE: if the error message appears again, call Technical Service.

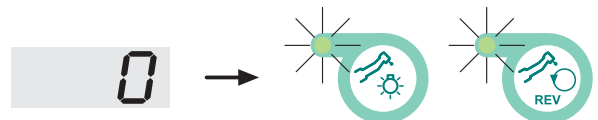
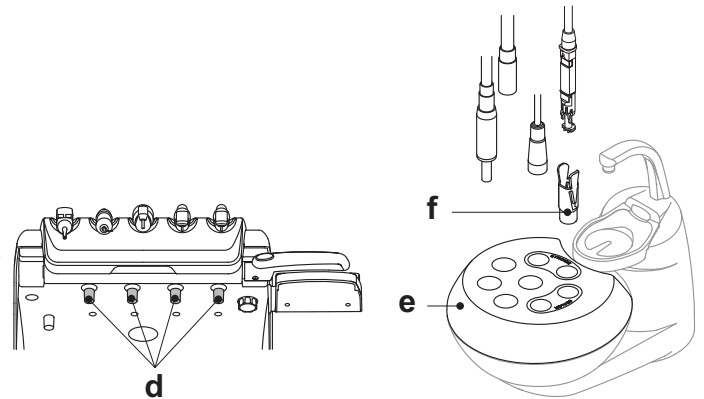
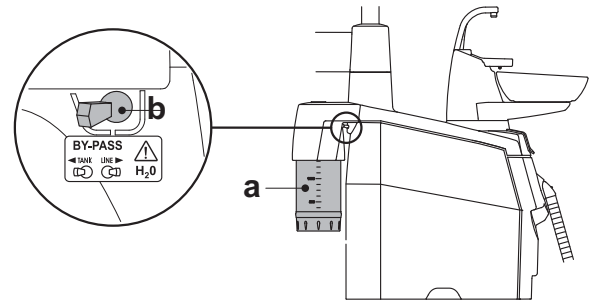

7.6. Opening/closing the side hydrogroup cover

Opening the cover.

- Open the cover on the side of the hydrogroup (a) after pushing up and releasing the lock lever (b).

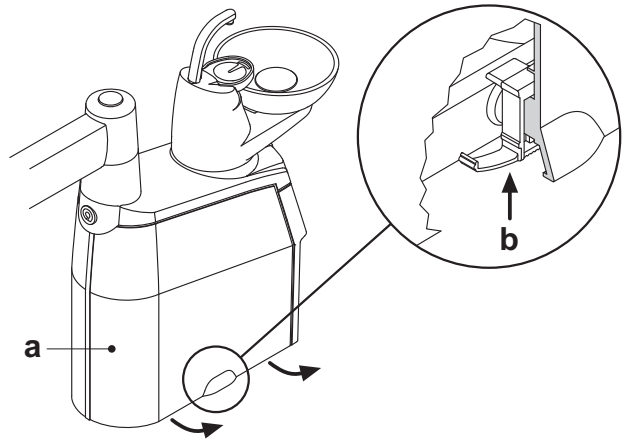

Closing the cover.

- Put on the cover making sure the two locks are inserted in the notches in the hydrogroup.
- Lastly, bring the bottom of the cover near the hydrogroup frame to engage the lock lever again.

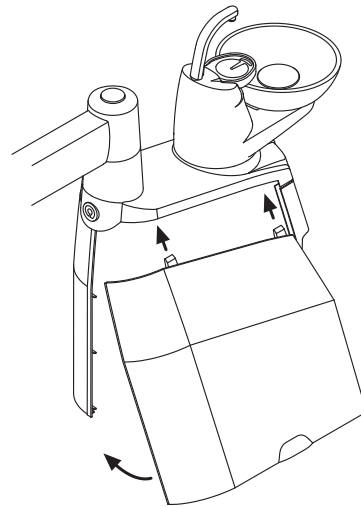

8. Accessories

8.1. Operating lamp

The operating lamp comes in 2 models:

- ① **Lamp with halogen light source, model VENUS E**
For the instructions for use and maintenance see paragraph 8.1.1.
- ② **Lamp with halogen light source, model VENUS PLUS.**
The instructions for use and maintenance of the halogen lamp model VENUS PLUS are available in PDF format and can be downloaded from the download area of the website www.anthos.com.

NOTE: during the automatic movements of the dental chair, the lamp automatically turns off to prevent blinding the patient.

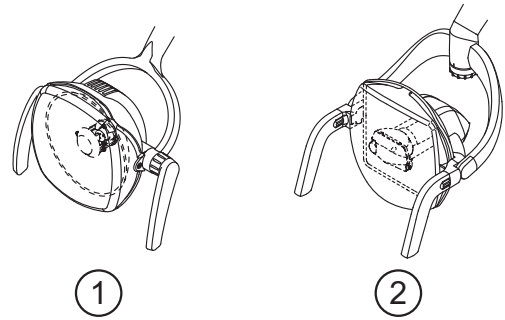

8.1.1. Operating lamp model VENUS E

Technical specifications.

- Operation: continuous.
- Power supply voltage: 12 V~ 50/60 Hz.
- Power absorbed: 55 W.
- Light spot dimensions: 70 mm X 140 mm.
- Lux: 24.000 (max).
- Colour temperature: 4.100 °K (+/- 5%).
- Maximum temperature on accessible surfaces (during normal use): < 85°C.
- Protection against electric risks: Class II type B.
- Light source: 12 V 55 W G6.35 halogen lamp
- Total weight: 7,3 kg

Safety warnings.



WARNING!

- The lamp must be installed by authorised staff.
- The lamp may only be used by authorised and adequately trained staff (dentists and paramedics) .
- Do not apply any weight on any point of the lamp and act on it only with the force necessary to move it.
- An operator must always be present when the lamp is on, in particular, it should not be left unattended in the presence of children/incompetent persons or in general persons not authorised for use.
- Do not carry out any maintenance operation on the lamp when the power is on. Cut the power before carrying out any operation on the lamp.
- The lamp is not suitable for use in the presence of a mixture of flammable anaesthetic gas with oxygen or nitrous oxide.
- The cleaning operations must be carried out with the lamp off and at room temperature. Do not spray detergent liquid directly onto parts of the optical unit.
- The lamp is not protected against penetration of liquids (IPX0).
- Do not apply protections, not even transparent, on the optical unit, which may obstruct the cooling air intakes.

Description.

- a) Optical Unit.
- b) Transparent screen.
- c) Removable handles.
- d) On/Off and brightness adjustment knob.
- f) Self-balancing arm.

Turning the lamp on and off.

- To turn on the lamp, turn the knob (d) clockwise.
- To turn off the lamp, turn the knob (d) fully anticlockwise.

Brightness adjustment

Turn the knob (d):

- Clockwise: increases the brightness.
- Anticlockwise: decreases the brightness.

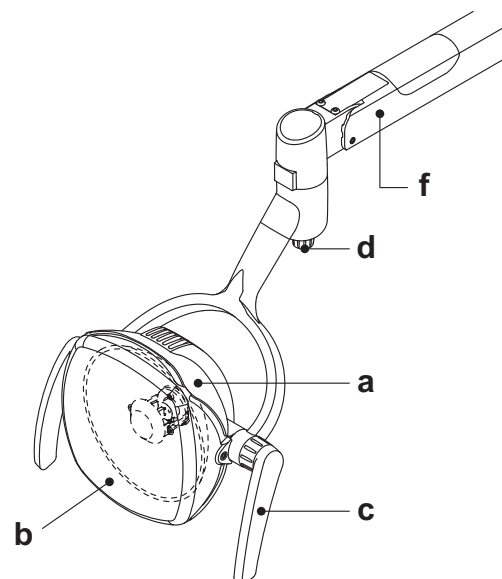

Removing the handles.



WARNING!

Carry out this operation with the lamp off.

Remove the handle (c) after turning the ring nut (e) anticlockwise.

Removing the transparent screen.



WARNING!

Carry out this operation with the lamp off and only after it has cooled down.

To remove the transparent screen (b) operate as follows:

- Remove the handles (c);
- Support the optical unit;
- Undo the 2 screws (g);
- Remove the transparent screen, gently pulling it outward.
- For refitting, follow the procedure in reverse order from removal.

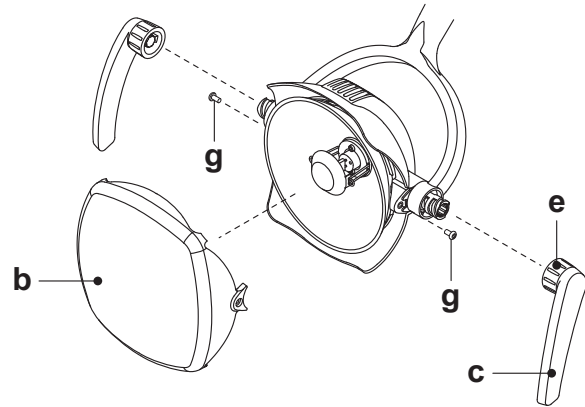

Cleaning and disinfection



WARNING!

Carry out these operations with the lamp off and after letting it cool down.

For cleaning and disinfection, use soft, non-abrasive disposable paper (avoid using recycled paper) or sterile gauze.

- Lamp arms and optical unit cover: clean the outer parts using STER 1 PLUS (CEFLA S.C.) or a similar product.
- Transparent screen: clean using a soft cloth for glass soaked in a solution of neutral soap and water.



WARNING!

Absolutely do not use products containing alcohol.

- Removable handles: the handles are cold-sterilizable (excluding the American and Canadian markets).
- **It is strictly prohibited to use abrasive substances and detergents based on trichloroethylene, benzene, turpentine or solvents in general on any part of the lamp.**
- **Do not spray the product used directly on the optical unit.**
- **Everything used for cleaning and disinfection must be thrown away after use.**

Replacing the bulb.



WARNING!

Carry out this operation after having cut the power to the device to which the lamp is connected and only after it has cooled down.

Operate as follows to remove the bulb:

- remove the handles;
- remove the transparent screen;
- remove the protective cover (h) of the bulb;
- remove the bulb (m) gently pulling it outward;
- fit the new bulb making sure that the contacts are fully inserted in the socket and that the bulb is in vertical position with respect to the mirror.



NOTE: DO NOT touch the new bulb with your hands, but handle it with the special protection.

If you have inadvertently touched the bulb, use a wad of cotton wool soaked in alcohol to remove your fingerprints.



WARNING!

The bulb must be the type specified in the technical specifications (REF V97710003).

- For refitting, follow the procedure in reverse order from removal.

Maintenance

The VENUS E operating lamp does not require any particular maintenance .



WARNING!

No parts can be repaired in the field. Should any malfunctioning occur, please call Technical Service.

Troubleshooting.

- **The bulb does not come on.**
 - Check that the power supply is connected.
 - Check that the bulb is securely inserted in its socket.

If none of the above caused the malfunction, call Technical Service.
- **Brightness has considerably reduced.**
 - Clean the parabola or the front screen using a soft cloth soaked in a glass cleaner.

Should brightness not return to the initial values, call Technical Service.
- **Brightness does not change when acting on the relative knob.**

Call Technical Service.

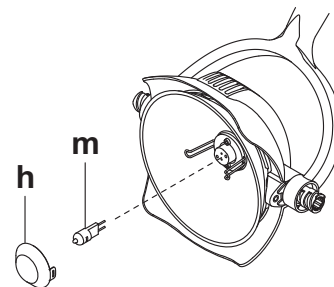

8.2. Monitor on lamp pole

The instructions for use and maintenance of the monitor are included with the dental unit.

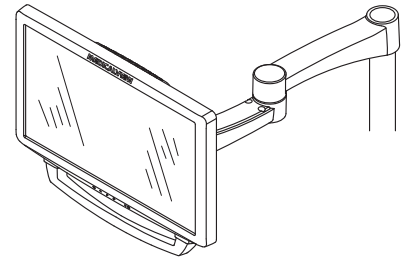

8.3. Negatoscope for panoramas

An x-ray film viewer for panoramic x-rays can be mounted on all INTERNATIONAL version instrument boards.

The screen dimensions are as follows: H=210mm, L=300mm.

Per accendere il negatoscopio è sufficiente agire sull'apposito interruttore (a):



= negatoscope on.



= negatoscope off.

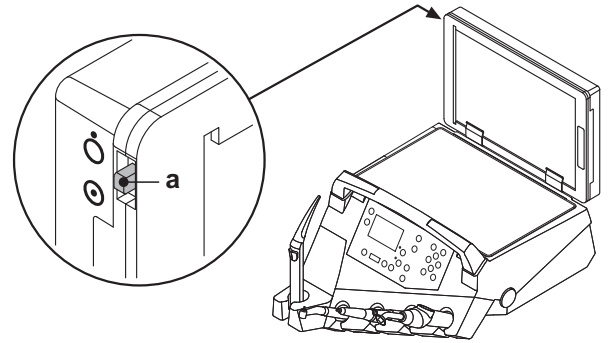

8.4. Air/water/230V quick-connect couplers

The 230V air/water quick-connect couplers are located in the front of the utility service centre.



WARNING!

Shut off the equipment before attempting to connect or disconnect the air/water outlets.

Technical specifications.

- Power outlet: 230VAC 2A in accordance with IEC/EN 60320-2-2/F (only on dental units with 230 VAC power supply).
- Air quick-connect coupler pressure: 6 Bar.
- Water quick-connect coupler pressure:
 - municipal water, 2.5 Bar
 - with S.H.S. system, 1,8 Bar
 - with W.H.E. system, 3 Bar
- Water quick-connect coupler delivery rate:
 - municipal water, 1800 ml/min
 - with S.H.S. system, 950 ml/min
 - with W.H.E. system, 400 ml/min



NOTE: with the SHS system, in order to use the quick-coupling with mains water, the distilled water tank needs to be disabled (see paragraph 7.2.).

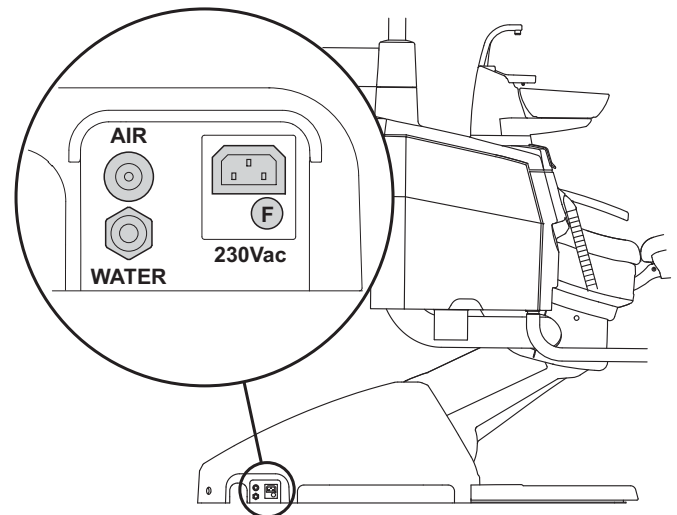

9. Maintenance

Preventive maintenance

Cefla sc - Cefla Dental Group, the manufacturer of the dental units, in accordance with applicable standards IEC 60601-1 3.a Ed. - 2007, IEC 62353 and directive MDD 93/42, and subsequent changes, for medical devices underlines that the preventive maintenance checks for the dental unit specified in the Technical care manual and Maintenance and warranty handbook are to be carried out by authorised personnel at least once every 12 months.

WARNING!

The warranty is void if the equipment is serviced, repaired, altered or modified in any way by personnel who have not been duly authorized by Cefla sc - Cefla Dental Group.

Safety checks

In accordance with standard IEC 62353, the safety checks specified in the Technical care manual and Maintenance and warranty handbook supplied with the dental unit are to be carried out at the intervals required by current local regulations. If no precise indications are given, Cefla sc, the manufacturer of the dental units, recommends checking them at least every 24 months at the time of installation and whenever electrical parts that are live are repaired/updated.

WARNING

The manufacturer shall not be held liable for any personal injury or equipment damage if the precautions given above are not observed.

9.1. Instrument maintenance

Maintenance instructions for the instruments are enclosed with each instrument.

WARNING!

Maintenance of the instruments should be carried out with the equipment shut off.

9.2. Draining condensate

Perform this operation every day before starting work.

Proceed as follows:

- put a container under the cock (a) found below the hydrogroup,
- loosen the cock's knob,
- after the tank has been emptied, fully close the cock.

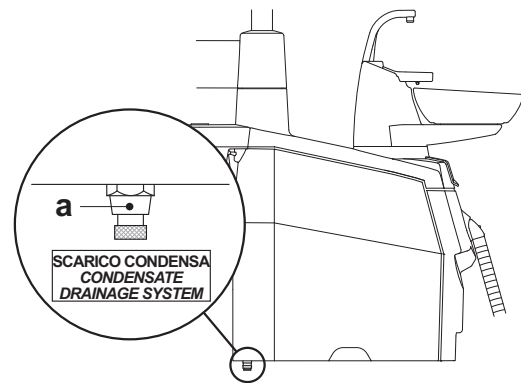

9.3. Cleaning the surgical suction filter

This operation should be done daily at the end of work.

WARNING!

Always wear gloves to prevent contact with infected material when cleaning the suction filter.

Proceed as follows:

- Take out the filter (d).
- Clean/replace the filter (code 97461845).
- Put the filter back in place being careful to removing any amalgam still present at the filter housing's entrance.

WARNING!

Remove any amalgam left at the seat of the filter before performing this operation.

NOTE: to prevent liquids and matter from dripping from the filter taken out, perform the operations given above with the suction tube running.

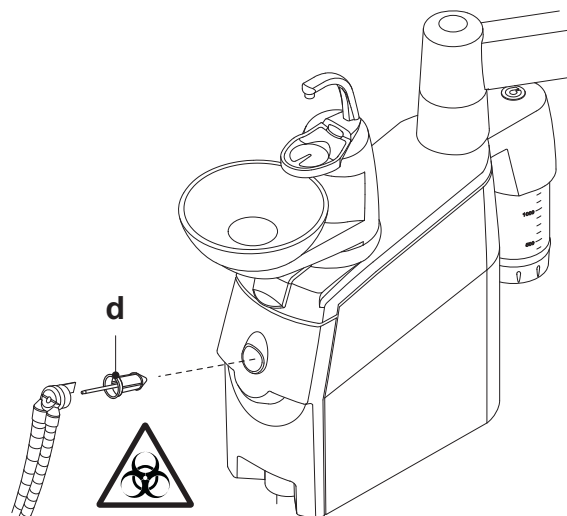

9.4. Surgical suction

The surgical suction system must be sanitized using a product suitable for this purpose.



WARNING!

For cleaning of the suction system, it is recommended to use **STER 3 PLUS (CEFLA S.C.)** diluted in a 6% solution (equivalent to 60 ml of product in 1 litre of water).

At the end of each surgical procedure.

- Suck in about half a liter of solution prepared with the selected disinfectant with each of the suction tubes used.
- Sterilize the cannula holder terminals in a steam autoclave at 135°C (2 bar) following the instructions for use of the device.

At the end of each work day.

- Draw in 1 liter of water with each suction tube, alternating water and air (keep the suction tube alternately in and out of the water).
- Once rinsed with water, draw in approximately half a liter of the solution prepared with the selected disinfectant with each of the suction tubes used.



WARNING!

Pay strict attention to all the disinfecting product manufacturer's instructions, warnings and cautions.



NOTE: after disinfecting, it is good practise to draw in air only to dry the entire suction system (5 minutes).

Once a week.

Remove the cannula body from its cord attachment and lubricate the O-rings (**o**) using **S1-Protective Lubricant for O-Rings** (CEFLA S.C.).

Once a year

Replace the suction tubes and ends of the tube holder.

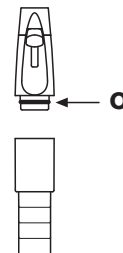
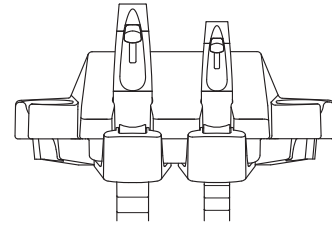

9.5. CATTANI surgical separator

At the end of each surgical procedure.

- Suck in about half a liter of solution prepared with the selected disinfectant with each of the suction tubes used.
- Sterilize the cannula holder terminals in a steam autoclave at 135°C (2 bar) following the instructions for use of the device.

At the end of each work day.

- Draw in 1 liter of water with each suction tube, alternating water and air (keep the suction tube alternately in and out of the water).
- Once rinsed with water, draw in approximately half a liter of the solution prepared with the selected disinfectant with each of the suction tubes used.

NOTE: after disinfecting, it is good practise to draw in air only to dry the entire suction system (5 minutes).

Every 15 days.

- Clean the separator container and probes with a soft sponge and neutral detergent.
- Clean the drain valve for the separator's container with the device provided for this purpose.

Once a year.

- By technician: check the siphons and drains, check all the internal tubes and plastic and rubber parts subject to wear.

Before leaving the surgery empty for a few days.

- Start the aspirator and run it 20 - 30 minutes without sucking in liquids. The aspirator will dry itself completely. As a result, salt caused by moisture and basic substances will not form, salt that may cause fan seizure and motor blockage.

How to remove the separator's container

WARNING!

Gloves must be worn when carrying out this operation to prevent contact with infected material.

- Move the dental chair fully up.
- Open the side hydrogroup cover (see paragraph 7.6.).
- Completely empty the separator bowl, pressing the timed button (**c**) located on the cover.
- If present, remove the valve (**s**) for central systems.
- Turn and raise the container (**d**) until it is detached from the drain pump (**k**).
- Detach the bowl (**d**) from the cover (**f**) pulling up the two side rubber bands (**e**).
- After the cleaning operations, refit the vessel (**d**) after lubricating the O-rings with S1-Protective Lubricant for O-Rings (CEFLA S.C.) O-ring before hand with silicon spray.
- Lastly, close the side hydrogroup cover.

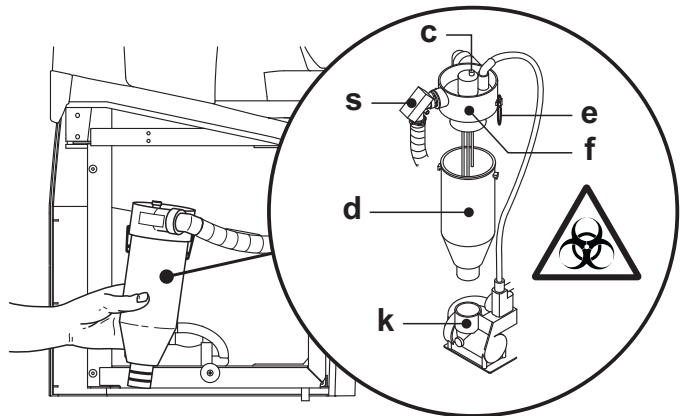
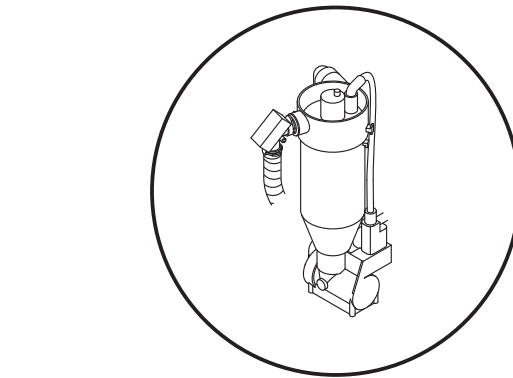

9.6. CATTANI gravity amalgam separator

Draining the separator's container.

- Move the dental unit completely up so that as much liquid as possible can be drained from the container.

WARNING!

Gloves must be worn when carrying out this operation to prevent contact with infected material.

- Turn the container (**m**) counter-clockwise and remove it.
- Refer to the instructions provided by CATTANI enclosed with the equipment to drain the container in the disposable container provided for this purpose (article code 97290027).

WARNING!

When disposing one-time use containers full of amalgam, observe current local and national laws.

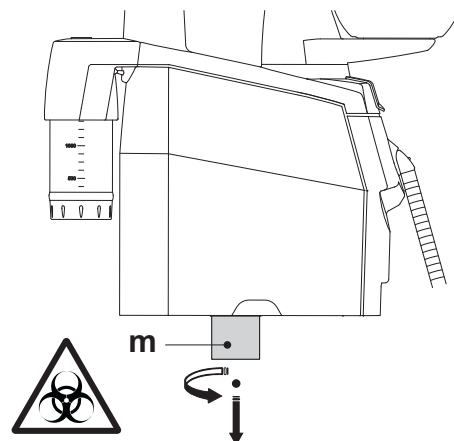

9.7. Cleaning the turbine return air filter

Monthly check the oil container filter (**g**) present in the turbine's return air line.
If necessary, replace the filter element (code 97290014).

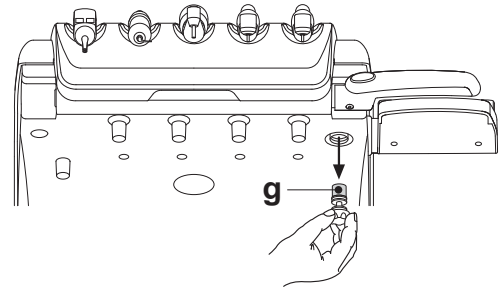

9.8. METASYS amalgam separator

The maintenance instructions for the METASYS amalgam separator are enclosed with the equipment if the equipment comes with this type of separator.
The separator's control device is located in the hydrogroup.



WARNING!

Always wear gloves to prevent contact with infected material when cleaning the separator.



WARNING!

When disposing one-time use containers full of amalgam, observe current local and national laws.

9.9. DURR amalgam separator

The maintenance instructions for the DURR amalgam separator are enclosed with the equipment if the equipment comes with this type of separator.
The separator's control device is located in the hydrogroup.



WARNING!

Always wear gloves to prevent contact with infected material when cleaning the separator.



WARNING!

When disposing one-time use containers full of amalgam, observe current local and national laws.

9.10. Dental chair

The dental chair does not need any special maintenance.
In any case, operation should be checked by ANTHOS authorized personnel once a year.

10. Specifications

Installation plan:	97042084
Technical manual:	97071147
Dental unit spare parts catalogue:	97023117
Dental chair spare parts catalogue:	97023117
Maximum dental unit weight:	90 Kg.
Maximum dental chair weight:	115 Kg.
Maximum dental chair capacity:	190 Kg.
Voltage:	230V~
Frequency:	50/60 Hz.
Power absorbed:	1500 W
Air connection:	1/2 Gas.
Air supply pressure:	6-8 bar.
Air delivery rate:	82 l/min.
Water connection:	1/2 Gas.
Water supply pressure:	3-5 bar.

Water delivery rate:	10 l/min
Water usage:	2 l/min.
Water hardness:	< 25 °f (14 °d).
Drain connection:	ø40 mm.
Drainage rate:	10 l/min.
Drain duct inclination:	10 mm/m.
Aspirator connection:	ø40 mm.
Vacuum (minimum):	65 mbar.
Vacuum delivery rate:	450 l/min.
Mark of approval:	CE 0051
Electrical work in compliance with:	IEC 60364-7-710
Dental unit packaging dimensions:	1570 x 780 x 1325(h)
Dental chair packaging dimensions:	1510 x 730 x 1000(h)
Dental unit packaging weight:	130 Kg.
Dental chair packaging weight:	150 Kg.

FUSES			
Identification	Value	Protection	Position
<i>Dental unit.</i> Fuse F2 Fuse F4 Fuse F5 Fuse F6	T 8 A T 6,3 A T 6,3 A T 6,3 A	230 V~:Dental unit power supply line. Secondary protection: Hydrogroup. Secondary protection: Dental unit. Secondary protection: Operatory light.	Electrical box. Electrical box. Electrical box. Electrical box.
<i>Dental chair.</i> Fuse F1	T 4 A	230 V~: Dental chair power supply line.	Electrical box.
<i>Quick-connect couplers.</i> Fuse	T 2 A	230 V~: Electrical outlet power supply line	Electrical box.
<i>MONITOR power supply.</i> Fuse	T 4 A	21 V~: MULTIMEDIA power line.	Dental chair card area.

10.1. A3PLUS CONTINENTAL dimensions

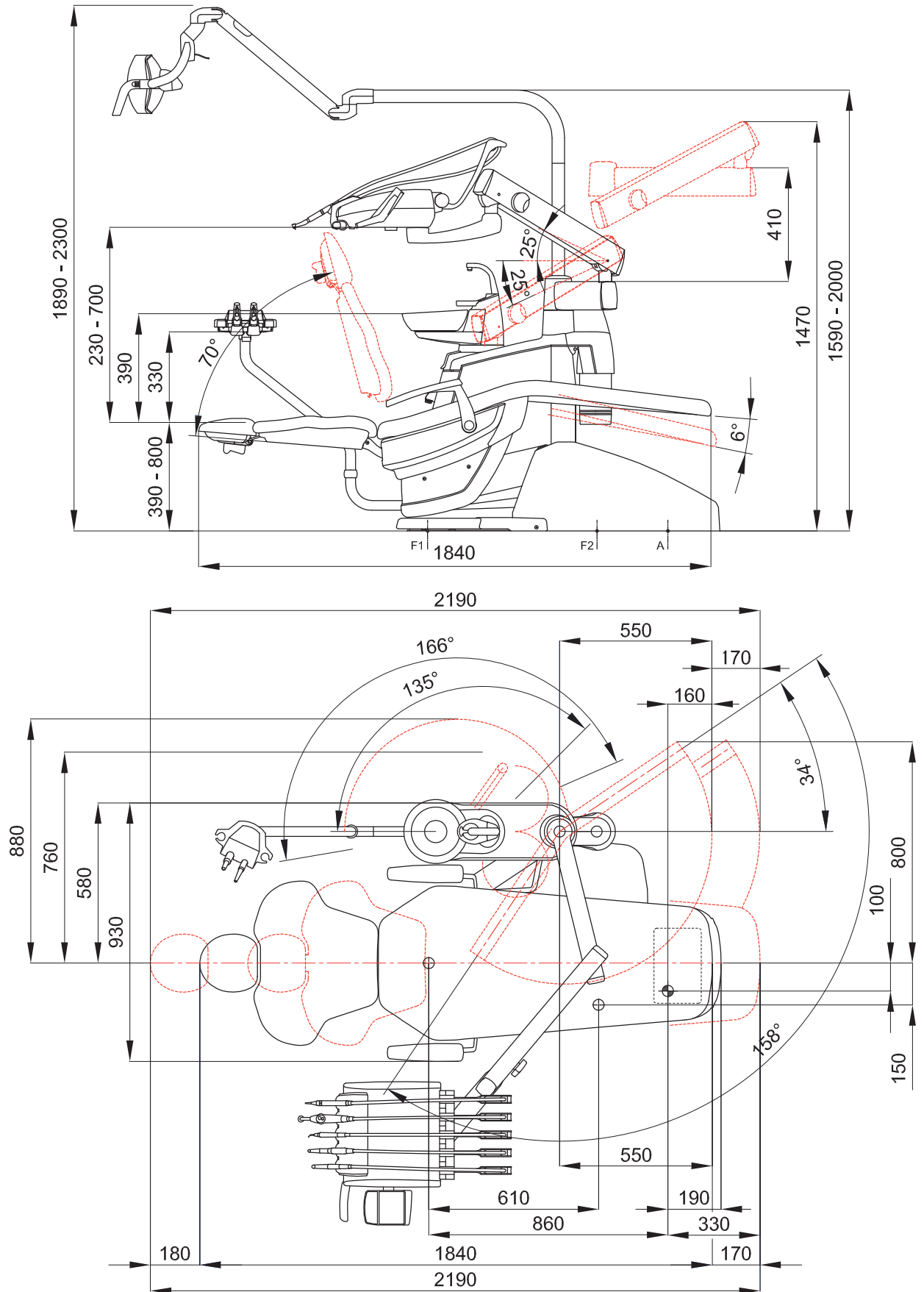

10.2. A3PLUS INTERNATIONAL dimensions

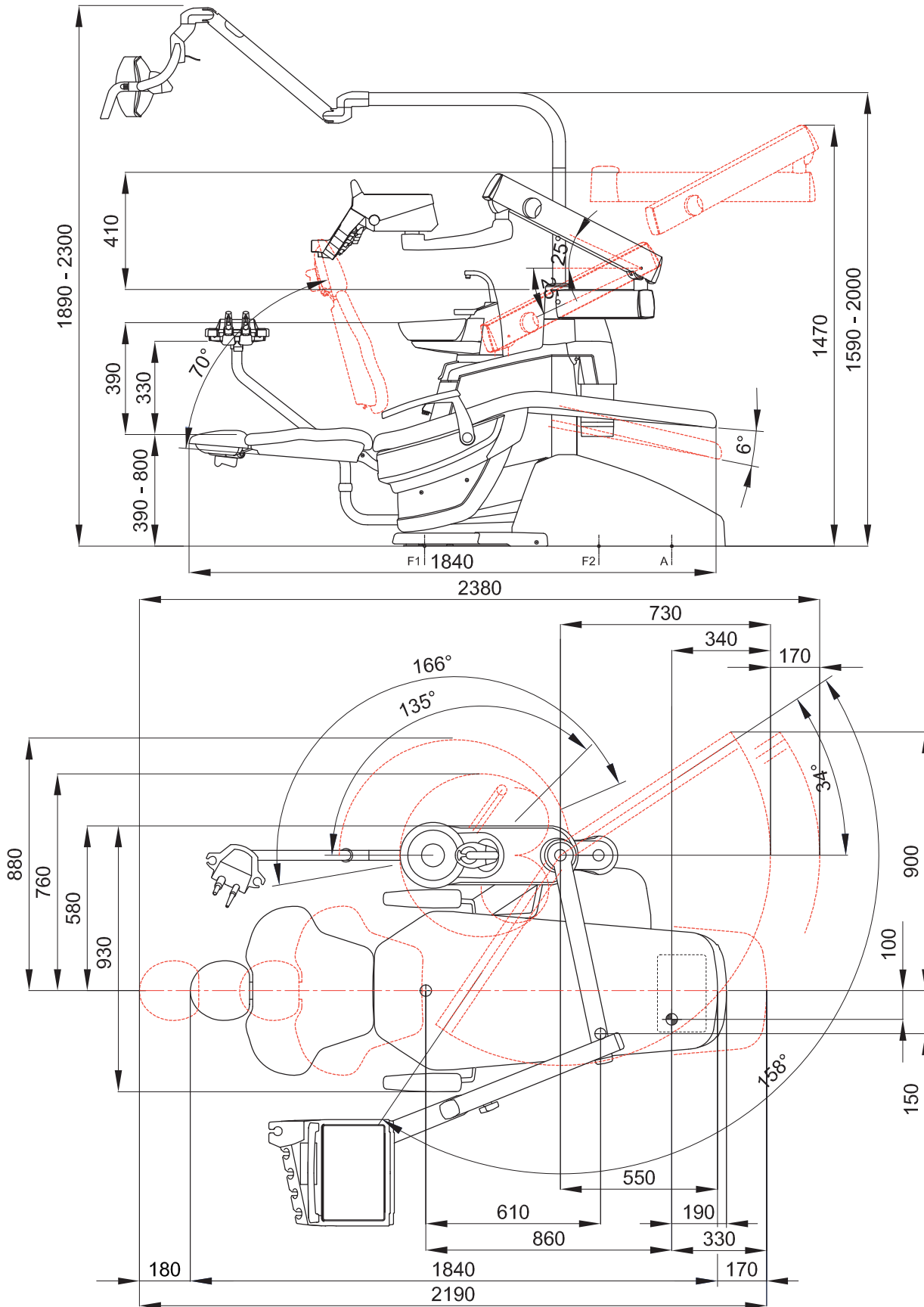

11. Dental operatory maintenance plan			
WHEN	PART	HOW	SEE PARAGRAPH
Before starting work.	Drain condensate.	/	See paragraph 9.2
After each treatment.	Contra angle handpiece.	Sterilize or disinfect the outside.	See documentation enclosed with handpiece
	Turbine.	Sterilize or disinfect the outside.	See paragraph 5.4
	Micromotor.	Disinfect outside.	See paragraph 5.5
	Scaler.	Sterilize or disinfect outside.	See paragraph 5.6
	Syringe.	Sterilize or disinfect outside.	See paragraph 5.3
	Curing lamp.	Sterilize fibre optic, disinfect outside.	See paragraph 5.7
	C-U2. camera.	Disinfect outside. Do not use acids or harsh products.	See paragraph 5.8
	Surgical suction tubes.	Aspirate about ½ litre of sanitizing solution with each cannula. Sterilize the cannula holder terminals.	See paragraph 9.4
When needed.	Bowl.	Clean with off-shelf detergents formulated for ceramic materials Do not use acids or harsh products.	See paragraph 7.1
	CATTANI gravity separator.	Drain separator's container.	See paragraph 9.6
	METASYS surgical separator.	See documentation supplied with the equipment.	/
	DURR surgical separator.	See documentation supplied with the equipment.	/
	Operatory light.	See documentation supplied with the equipment.	/
	Monitor with light pole.	See documentation supplied with the equipment.	/
	Removable instrument cords.	Clean with a suitable disinfectant carefully following the directions for use provided by the manufacturer. Spray the product on soft disposable paper towels. Do not use acids or harsh products.	See paragraph 5.
	Coated surfaces and dental chair upholstery.	Clean with a suitable disinfectant carefully following the directions for use provided by the manufacturer. Do not use acids or harsh products.	See paragraph 1.4
At the end of the work day.	Bowl filter.	Clean filter in running water The content must be disposed of separately	See paragraph 7.1.
	Surgical suction filter.	Check the filter and replace it if the suction rate is reduced (code 97461845).	See paragraph 9.3.
	Surgical suction tubes.	Aspirate about ½ litre of sanitizing solution with each cannula and then dry. Sterilize the cannula holder terminals.	See paragraph 9.4.
	Hydraulic saliva ejector.	Clean the filter of the saliva ejector terminal.	See paragraph 6.6
Weekly.	CATTANI surgical separator.	Clean the separator's container, drain valve and probes.	See paragraph 9.5.
	Cannula holder terminals.	Lubricate the O-rings.	See paragraph 9.4.
Monthly.	Turbine return air filter.	Check the filter and replace it if necessary (code 97290014).	See paragraph 9.7.
Yearly.	Dental chair.	Contact the technical service department for general inspection.	/

DICHIARAZIONE DI CONFORMITÀ “CE / EU” / “CE / EU” CONFORMITY DECLARATION
DECLARATION DE CONFORMITÉ “CE / EU” / ERKLÄRUNG VON “CE / EU” ZUSTIMMUNG / DECLARACION DE CONFORMIDAD “CE / EU”
DECLARAÇÃO DE CONFORMIDADE “CE / EU” / ΔΗΛΩΣΗ ΠΙΣΤΟΤΗΤΑΣ “CE / EU” / ДЕКЛАРАЦИЯ СООТВЕТСТВИЯ “CE / EU”
DEKLARACJA ZGODNOSCI WE “CE / EU” / “CE / EU” UYGUNLUK BELGESİ

Prodotto tipo/ Product type :

Incollare in questo spazio l'etichetta del complesso odontoiatrico o di altra apparecchiatura o indicare modello e numero di matricola
Stick the label of the dental equipment or other device into this space or write model and serial number

Matr./ Serial N°:

- I Dichiaro sotto la nostra esclusiva responsabilità che i prodotti ai quali questa dichiarazione si riferisce sono conformi
1) ai requisiti essenziali (Allegato I) presenti nella direttiva 93/42/CEE Dispositivi Medici (D.Lgs.46/97) e successive modifiche ed integrazioni (**dispositivo medico di Classe IIa**)
2) alla direttiva 2011/65/UE del Parlamento europeo e del Consiglio dell'8 giugno 2011, sulla restrizione dell'uso di determinate sostanze pericolose nelle apparecchiature elettriche ed elettroniche (Rohs 2)
- GB We declare, on our sole responsibility, that the products referred to herein are in compliance with
1) the essential requirements (Annexe I) of Directive 93/42/EEC Medical devices (Leg. Decree 46/97) and subsequent amendments and integrations (**Class IIa medical device**)
2) Directive 2011/65/EU of the European Parliament and of the Council of 8 June 2011 on the restriction of the use of certain hazardous substances in electrical and electronic equipment (Rohs 2)
- F Nous déclarons, sous notre complète responsabilité, que les produits auxquels la présente déclaration fait référence sont conformes
1) aux exigences essentielles (Annexe I) présentes dans la directive 93/42/CEE "Dispositifs médicaux" (Décr.L. 46/97) et modifications successives et intégrations (**dispositif médical de Classe IIa**)
2) à la directive 2011/65/UE du Parlement européen et du Conseil du 8 juin 2011 relative à la limitation de l'utilisation de certaines substances dangereuses dans les équipements électriques et électroniques (Rohs 2)
- D Wir erklären hiermit in alleiniger Verantwortung, dass die Produkte, auf die sich diese Erklärung bezieht, konform sind mit
1) den grundlegenden Anforderungen (Anhang I) der Richtlinie 93/42/EWG über Medizinprodukte (Gesetzesverordnung 46/97) und nachfolgenden Änderungen und Ergänzungen (**medizinisches Gerät der Klasse IIa**)
2) der Richtlinie 2011/65/EU des Europäischen Parlaments und des Rats vom 8. Juni 2011 zur Beschränkung der Verwendung bestimmter gefährlicher Stoffe in Elektro- und Elektronikgeräten (Rohs 2)
- E Declaramos bajo nuestra exclusiva responsabilidad que los productos a los que esta declaración se refiere, están conformes con
1) los requisitos esenciales (Anexo I) presentes en la directiva 93/42/CEE Dispositivos Médicos (D. Leg. 46/97) y sucesivas modificaciones e integraciones (**dispositivo médico de Clase IIa**)
2) la directiva 2011/65/UE del Parlamento europeo y del Consejo del día 8 de junio de 2011, sobre la restricción del uso de determinadas sustancias peligrosas en aparatos eléctricos y electrónicos (Rohs 2)
- P Declaramos sob a nossa exclusiva responsabilidade que os produtos aos quais esta declaração se refere estão em conformidade
1) com os requisitos essenciais (Anexo I) presentes na diretiva 93/42/CEE Dispositivos Médicos (em Itália, transposta pelo Decreto Legislativo 46/97) e posteriores alterações e aditamentos (**dispositivo médico de Classe IIa**)
2) com a diretiva 2011/65/UE do Parlamento europeu e do Conselho de 8 de junho de 2011, relativa à restrição do uso de determinadas substâncias perigosas em equipamentos elétricos e eletrónicos (Rohs 2)
- GR Δηλώνουμε με την αποκλειστική ευθύνη μας ότι τα προϊόντα στα οποία αναφέρεται η παρούσα δήλωση είναι σύμφωνα
1) με τις βασικές απαιτήσεις (Προσάρτημα I) της οδηγίας 93/42/ΕΟΚ Ιατροτεχνολογικών Προϊόντων (Ν. Διάτ.46/97) και μεταγενέστερες τροποποιήσεις και συμπληρώσεις (**ιατροτεχνολογικό προϊόν Κατηγορίας IIa**)
2) με την οδηγία 2011/65/ΕΕ του Ευρωπαϊκού Συμβουλίου και του Συμβουλίου της 8 Ιουνίου 2011, για τον περιορισμό της χρήσης ορισμένων επικίνδυνων ουσιών σε ηλεκτρικό και ηλεκτρονικό εξοπλισμό (Rohs 2)
- PY Под нашу исключительную ответственность заявляем, что изделия, к которым относится данная декларация, соответствуют
1) основным требованиям (Приложение I) директивы 93/42/ЕЭС Медицинские устройства (Законодательный указ № 46/97) и последующим изменениям и дополнениям (**медицинское устройство Класса IIa**)
2) директиве 2011/65/ЕС Европарламента и Совета Европы от 8 июня 2011 года по ограничению использования определенных опасных веществ в электрическом и электронном оборудовании (Rohs 2)
- PL Oświadczamy na swoją wyłączną odpowiedzialność, że produkty objęte niniejszym oświadczeniem są zgodne:
1) z zasadniczymi wymaganiami (Załącznik I) przewidzianymi dyrektywą 93/42/EWG WYROBY MEDYCZNE (D. z mocą ustawy 46/97) wraz z późniejszymi zmianami i uzupełnieniami (**wyrób medyczny Klasa IIa**)
2) z dyrektywą 2011/65/WE Parlamentu europejskiego i Rady z dnia 8 czerwca 2011r. w sprawie ograniczeń we wprowadzaniu do obrotu i stosowaniu w sprzęcie elektrycznym i elektronicznym określonych niebezpiecznych substancji (Rohs 2)
- TR Bu beyannamede bahsi geçen ürünlerin aşağıda belirtilenlere uygun olduğunu kendi münhasır sorumluluğumuz altında beyan ederiz:
1) (Kanun hükmünde Kararname 46/97) Medikal Aygıtlar 93/42/CEE direktifinde mevcut (Ek 1) ana gereklilikler ve sonraki değişiklikler ve eklemelerde belirtilenler (**IIa sınıf medikal aygıt**)
2) 8 Haziran 2011 tarihli Avrupa Parlamentosu ve Konseyi'nin "Elektrikli ve elektronik cihazlarda bazı tehlikeli maddelerin kullanılmasına ilişkin kısıtlamalar" 2011/65/UE direktifi (Rohs 2)

Imola, li _____

Bussolari Paolo
Managing Director