



User's Manual

Version 3.0
Released: 08.09.2005



**Important Information,
Please Read Before Use!**

KLING & FREITAG GmbH
Junkersstrasse 14
D-30179 Hannover
PHONE 0 (049) 511- 969 97-0
FAX 0 (049) 511- 67 37 94
www.kling-freitag.de



Thank you for your decision to buy a Kling & Freitag product. To guarantee a trouble-free operating of the equipment and to allow the KLING & FREITAG – CA 1001 System to achieve its full potential please read the operating instructions carefully before use.

With the purchase of a CA 1001 System, you have acquired a speaker system with the highest possible quality and performance capabilities.

As the owner of a CA 1001 System, you now have a versatile and highly professional tool which, when operated properly, is a true pleasure to use.

Symbols in User's Manual



This symbol indicates the possibility of life-threatening danger and a health risk for persons. Not following these instructions may result in serious health problems including potentially fatal injuries.



This symbol indicates a possibly dangerous situation. Not following these instructions may cause minor injuries or cause property damage.



This symbol gives instructions for the proper use of the described products. Not following these instructions may cause malfunctions or property damage.

Information about this User's Manual

User's Manual CA 1001 Version 3.0, 08.09.2005

© by André Figula, Kling & Freitag GmbH, 1995 - 2005; all rights reserved.

All specifications in this manual are based on information available at the time of publishing for the features and safety guidelines of the described products.

Technical specifications, measurements, weights and properties are not guaranteed.

The manufacturer reserves the right to make product alterations within legal provisions as well as changes to improve product quality.

All persons who use the speaker system must have this guide and all further information for safe operations available to them during assembly, disassembly, and use.

We appreciate any input with suggestions and improvements for this manual. Please send this to us at the following address:

info@kling-freitag.de or to:

KLING & FREITAG GMBH Junkersstr.14 D-30179 Hannover

Phone +49 (0) 511 - 96 99 70 Fax +49 (0) 511 - 67 37 94

Contents

Chapter	Page
1. General Safety Instructions for Using Speakers	5
2. Product Description and Versions	7
3. Important Notes for the 'Outdoor Mobile' Option	7
3.1 Features of the 'Outdoor Mobile' Option	7
4. Instructions for Versions with '100 V' Option	8
4.1 Reasons for choosing Speakers with 100 V Technology	8
4.2 Connecting Diagram of the 100V Speaker Inputs	8
5. Instructions for Suspending the Speakers	8
6. Coverage Angles of the CA 1001 Speaker	9
6.1 Changing the Coverage Angles	9
7. Mounting Instructions for Speakers	10
7.1 Proper Arrangement of the Loudspeakers	10
7.2 Arrayed Speaker Systems (Cluster)	11
7.2.1 Horn not rotated	11
7.2.2 Horn rotated	12
8. Wiring	13
8.1 Connecting the Speakon Connector to the Terminal	13
8.2 Avoiding Ground Loops	14
8.2.1 What is a Ground Loop?	14
8.2.2 Avoiding Ground Loops	14
9. Configurations and Connecting Diagrams	15
9.1 Operating the Systems without C2 Controller	15
9.1.1 CA 1001 Systems in Full-Range Mode	15
9.1.2 Full-Range Mode & Subwoofer with Crossover (XO)	16
9.2 Operations with C2 Controller	17
9.2.1 Full-Range Mode with K&F C2 Controller	18
9.2.2 CA 1001 & Bass with Controller C2 in 2-Way Active Mode	19
10. Operating the Speakers	20
11. Crossovers: Wiring Diagram CA 1001	21
12. Touching Up Damage to Paint / Changing the Front Foam	21
13. Technical Specifications CA 1001	22
14. Measuring Charts	23
15. Dimensions	25
16. Accessories	26
17. Regulations for Disposal	27
17.1 Germany:	27
17.2 EU, Norway, Island, and Liechtenstein (not Germany):	27
17.3 Other countries	27
17. Included Safety and Mounting Instructions for Loudspeakers and Accessories	

1. General Safety Instructions for Using Speakers



Warning

Mounting the speakers

To prevent injury, the speakers must be securely placed on the floor or secured to the wall according to the instructions on page 10 (Mounting Instructions for Speakers).

Please note that speakers can move as a result of vibrations. To prevent them from falling from their mounted position, they must be secured properly. If the weight of the speaker exceeds 20 kg then it is necessary for two people to carry it.

Speakers may only be suspended or mounted to walls or ceilings by qualified personnel. The speakers must be hung by using at least two of the designated flying points. The same applies when lifting and aligning the speakers.

Never use signal cables or power cords for suspending, aligning or securing the systems. When laying the connecting cables, make sure that nobody can trip.

Never hang more than two speakers under one another without using the designated Kling & Freitag rigging equipment.

Ensure that all installation connections comply with the applicable safety guidelines and that the size and strength are sufficient. Further instructions are in our user's manual for assembly equipment and in the general safety instructions for speakers and assembly equipment.

For mobile and fixed installations, use only rigging equipment from KLING & FREITAG. Make sure to observe the included safety and mounting instructions for loudspeakers and accessories.

Speakers and rigging equipment must be visually examined at regular intervals. If there are signs of wear, they must be replaced immediately. Furthermore, screwed connections of supporting parts must be checked routinely.

Protecting the speakers / avoiding fire hazard

In general, audio signals should not be overdriven. This may be caused by mixing consoles, equalizers, effect equipment, etc. and should be indicated on this equipment. When a power amplifier is overloaded at the output (clipping), then the amplifier should activate a clipping warning signal. Power amplifiers can also be overloaded at the input circuit without the amplifier signalling the clipping, i.e. when there is not sufficient headroom in the input circuit. We, therefore, recommend turning up the power amplifiers all the way and adjusting the level before the power amplifier in order to avoid overloading the input circuit. In any case, the signal must be reduced as soon as it sounds unnaturally distorted.

- To protect the speakers from being destroyed and to avoid fire hazard, they should only be operated with professional power amplifiers with the following specifications:
 - Integrated or preceding subsonic filter (approx. 20 Hz, min. 12 dB / octave)
 - integrated clipping limiter
 - maximum rated power 500W@6 Ohms (equivalent 750W@4 Ohms)
- If you wish to use a speaker with a power amplifier which does not fulfil these specifications, then the speaker should be controlled using a Kling & Freitag system controller with limiter function. This is the only way overloading and that the risk of fire can be avoided. The results of such a power amplifier defect of cannot be avoided by the controller.
- If power amplifiers have power ratings lower than mentioned above, then it is imperative that a clipping limiter is used to protect the speaker even if it is used with a Kling & Freitag system controller.

For damage caused by overloading or use with power amplifiers other than those recommended above, Kling & Freitag GmbH does not assume warranty and excludes liability for possible consequential damage.



Warning



Important

The following signals may damage the speakers

- permanent high-pitched signals with high frequency, and continuous noise from feedback.
- permanently distorted signals with high power.
- noises, which occur when the amplifier is on while equipment is being connected, disconnected or switched on.

Do not install devices in any of the following places:

- where the devices are permanently exposed to direct sunlight.
- where the devices are exposed to high moisture.
- where the devices are exposed to strong vibrations and dust.

Damage caused by the speakers' magnetic fields

Speakers are permanently surrounded by a magnetic field even when they are not operating. Therefore, during transport and placement of the speakers, it is important to ensure that there is always approx. 1 m between the speakers and magnetic data media and computer/video monitors.

Preventing hearing damage

To prevent the risk of hearing damage, avoid being too close to operating speakers even if the volume level seems to be low enough. In general, volume levels over 90 dB can cause hearing damage.



Important



Caution

2. Product Description and Versions

Short description:

Passive 2-way full-range loudspeaker with 10" low-mid chassis and 1" high frequency driver on a rotatable 85° x 55° CD horn. Integrated passive crossover with passive delay time and phase correction, self-resetting protection circuits for low-mid and high frequency path. Precise coverage and constant directivity starting at 1000 Hz. Easy plug & play operations without additional electronics. Optional operations via System Controller C2.

Enclosure:

Multi-functional 15 mm birch plywood enclosure with highly resistable structured black PU paint. Features: Integrated monitor angle and handle, thread inserts 5 x M10 and 2 x M8 for flexible mounting, compatible with optional accessories (e.g. stand adapter, tilt brackets), ball proof steel grille with 70% permeability, mounted with 4 screws, exchangeable black acoustic foam front covering.

The CA 1001, with its compact construction, its light weight and high performance capability is eminently suitable for mobile use in the standard version. Its discreet design also makes the CA 1001 suitable for fixed installations.

Special versions:

- CA 1001 '100V'
Version with 100V / 300VA toroidal transformer
- CA 1001 'Outdoor Mobile'
Version for outdoor use under roofs
- Special finish in RAL colours
- CA 1001 - SP:
Version with integrated power amplifier technology
'SP' speakers are shipped with a special user's manual!

3. Important Notes for the 'Outdoor Mobile' Option

The CA 1001 is available with the option 'Outdoor Mobile'.

Speakers with the option 'Outdoor' have been optimised for outdoor use. They withstand temperature fluctuations in moderate climate zones and do not accumulate condensation water.

In order to guarantee the longevity and safety of the speakers, the speakers with the option 'Outdoor' must still be protected from direct effects of the weather.

They should be installed, for example, under a roof so that they also have sufficient protection from driving rain from the side and direct sunlight.



3.1 Features of the 'Outdoor Mobile' Option

Version for mobile outdoor use under roofs.

Features like standard version but with the following extras:

- multi-layered, temperature and UV-resistant high-tech PU marine primer,
- final coating with highly resistant structured 2K paint in RAL colours,
- waterproofed diaphragms and electronic components protected against corrosion with protective coating.

4. Instructions for Versions with '100 V' Option

Kling & Freitag speakers with '100V' option are fitted with high-quality toroidal transformers. This serves to minimize loss of sound. Highly professional sound reinforcement results can be achieved using 100 V Kling & Freitag speakers.

4.1 Reasons for choosing Speakers with 100 V Technology

- Reduction in conduction loss.
- Easy installation of a loudspeaker network due to simple parallel wiring.
The sum of the output power of the individual speakers (stated as VA = W) must not exceed the output power of the 100 V amplifier.
- Speakers are galvanically isolated.
- Speakers can be integrated into existing 100 V systems.



4.2 Connecting Diagram of the 100V Speaker Inputs

The 100 V transformer for the CA 1001 has one 300VA tap. The pin connections can be seen below.

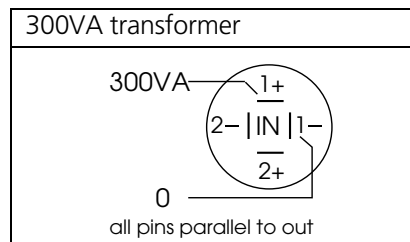

5. Instructions for Suspending the Speakers

The speakers may only be suspended by trained specialised personnel with proof of their qualifications.

Observe the prescribed safety factors. Follow the safety instructions for speakers and mounting equipment as well as the respective national rules, norms and safety regulations.

Speaker systems, whether single or connected to one another, must always be secured to a second separate point, even if two rigging points are used for suspending the speaker system!

Ensure that all connections are secured to prevent their detaching on their own and that only admissible statically tested and sufficiently sized mounts, connecting devices, ropes and chains are used.

We recommend using the M8 threads only for mounting stand adapters and TV-spigot adapters. The M10 threads should be used for mounting the CA 1001 tilt brackets only. Eyebolts can be attached to the M8 and M10 threads in order to suspend the speakers, if they are dimensioned sufficiently (safety factor 12) and are used as described by the manufacturer.

Pease note:

- The M10 thread inserts can only support weights up to 50 kg each.**
- The M8 thread inserts can only support weights up to 12.5 kg each.**



6. Coverage Angles of the CA 1001 Speaker

The CA 1001 can be operated in a vertical or horizontal (i.e. as a stage monitor) position. The coverage pattern of the speaker can be adapted to special needs by a 90° rotatable horn.

The table below shows the coverage angles of a standing speaker: To determine the coverage pattern of the high frequency horn, shine a flashlight through the front covering at the level of the horn. You will find a silver stripe that determines the position and thus the coverage angles of the horn.

DEFINITION:

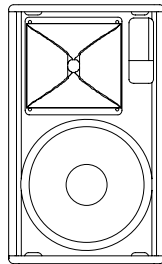

Standing speaker:

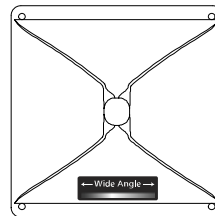

Horn not rotated

85° h x 55° v

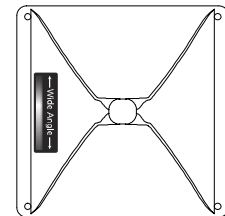

Horn rotated

55° h x 85° v

6.1 Changing the Coverage Angles

To turn the horn, follow these steps:

- 1) Remove the four grille mounting screws on the top and bottom of the speaker with a 3 mm allen key and remove the grille from the speaker enclosure.
- 2) Remove the 4 screws securing the high-frequency horn (also 3 mm allen key). Extract the horn from the top. Should the horn adhere to the foam rubber attached below, release it using a screwdriver or something similar to gently lever it up.
- 3) Rotate the horn 90° and screw the horn on tightly again (do not force it!).
- 4) Screw the grille on tightly.



If the coverage angle needs to be changed often, make sure that the horn is not always rotated in the same direction, as the connecting cables, when twisted, may causing the contacts of the driver to become loose.

7. Mounting Instructions for Speakers

Mount the speakers securely. To avoid injury or damage, always be sure to mount the speakers securely so that they do not fall. Speakers, which are stacked, must be secured with securing straps. When laying the connecting cables, make sure that nobody can trip.

The stability of stacked systems (also valid for the use of stands and distance rods!) is contingent upon the following stability requirement. These conditions must, therefore, be guaranteed by the user:

Stacked systems may not fall over even if they are inclined by 10° in each direction. If this requirement is not fulfilled, then it is necessary to take steps to achieve compliance. Possible measures include strapping it to an appropriate base structure or fastening it using safety straps.

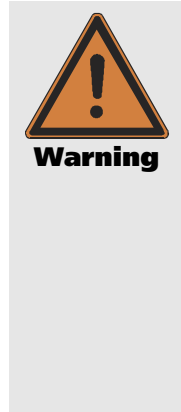

7.1 Proper Arrangement of the Loudspeakers

Be aware of the fact that the logical targeted alignment of this high quality speaker system can lead to a significant qualitative increase in the acoustic result. It is not possible to make generalities about the alignment of specific systems because the room has a substantial influence on the signal and the audible result.

As a rule, the mid- and high-transducers of loudspeakers should be mounted above the audience's face value, so that the sound distribution cannot be shadowed.

In many cases it is advisable to mount a loudspeaker higher, so that the sound will be distributed throughout the room more evenly. Low standing systems result in a greater difference in volume between front and back seats than higher standing systems.

Please note that this is only a general guideline and the best possible result may vary from room to room.

To simulate the correct alignment of the speakers beforehand, there are various programs such as 'Ease' or 'Ulysses'. The Kling & Freitag speaker system data is available for download on our website www.kling-freitag.de.

The following graphics will assist in making a rough estimate as to the distance range of the CA 1001. The graphics only take into consideration the sum of the direct sound and not the influence of the room. Because of this there can, in some cases, be noticeable deviation.

Distance range of SPL (direct sound level):



7.2 Arrayed Speaker Systems (Cluster)

If the loudspeakers are operated through the optional K&F C2 System Controller, we recommend turning on the 'Top Low Cut' switch for clustered operation. Thus the frequency response for this application can be optimised (see also K&F C2 User's Manual).

When operating the systems without the K&F C2 System Controller in a clustered configuration, the signal level of frequencies below 300 Hz should be reduced by 3-4 dB.

7.2.1 Horn not rotated

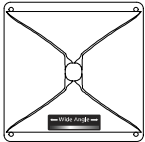
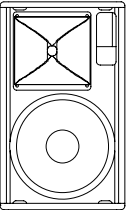
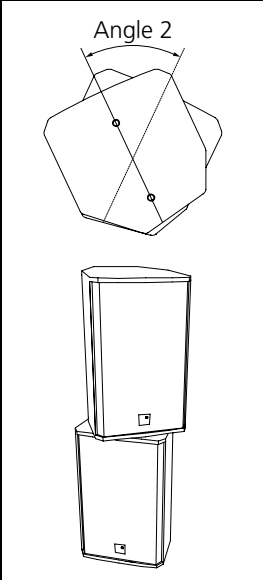
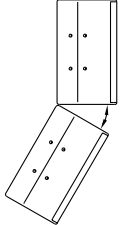
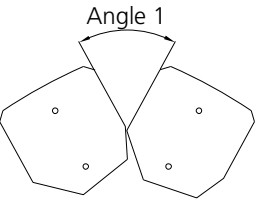
			 <p>Angle 3</p> <p>A smaller angle 3 results in a smaller vertical coverage angle but increases the sound power level.</p>
<p>Horn not rotated</p>		<p>Angle 2</p>	<p>Angle 3</p>
<p>Application</p>	<p>Angle 1</p>	<p>Angle 2</p>	<p>Angle 3</p>
<p>Application</p>	<p>Increasing the horizontal coverage angle, e.g. for wide audience planes</p>	<p>Increasing the horizontal coverage angle and sound power level for larger distances</p>	<p>Increasing the vertical coverage angle, e.g. for covering balconies or for increased sound power level for larger distances</p>
<p>Application</p>	<p>50° not generally recommended*</p>	<p>30°</p>	<p>30°</p>

*If several 90° systems are clustered, unwanted interference effects may appear. As a result, we do not generally recommend clustered configurations of CA 1001 systems. If wide angles are to be covered, we recommend the use of several systems with rotated horns in one cluster.

7.2.2 Horn rotated

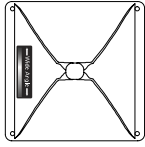
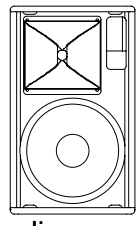
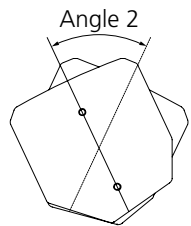
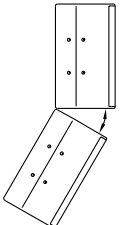
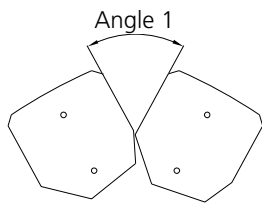
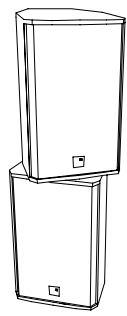
 <p>Horn rotated</p>	 <p>Standing speaker</p>	 <p>Angle 2</p>	 <p>Angle 3</p>
	 <p>Angle 1</p>		<p>A smaller angle 3 results in a smaller vertical coverage angle but increases the sound power level.</p>
	<p>Angle 1</p>	<p>Angle 2</p>	<p>Angle 3</p>
	<p>30°</p>		<p>50°</p>
<p>Application</p>	<p>Increasing the horizontal coverage angle, e.g. for wide audience planes</p>	<p>Increasing the horizontal coverage angle and sound power level for larger distances</p>	<p>Increasing the vertical coverage angle, e.g. for covering balconies or for increased sound power level for larger distances</p>

8. Wiring

The speaker is equipped with two parallel Speakon connectors.

Make sure that all units are switched off and all controls are turned down before connecting your CA 1001 systems.

- We recommend the use of high-quality speaker cables provided by KLING & FREITAG.
- For connections to the power amplifier inputs, please use 2-pin shielded microphone cable with high-quality connectors.
- Avoid ground loops (see chapter 8.2)
- Please pay attention to the respective pin diagrams in this manual!
- Make sure that the +/- polarity of the speakers at the amplifier is correct. When simultaneously using power amplifiers from different manufacturers, be sure to use the correct specific pin configuration. It may be necessary to modify the pin configuration on the power amplifiers or on the connectors leading to them.
- Upon completing the wiring, ensure that the connected speaker channels are working in phase. To do so, use i.e. a phase checker. A phase error can also be recognized when the connected channels are used simultaneously. During simultaneous use the bass frequencies become notably quieter or the mid-frequencies such as voices cannot be located.
- To avoid loss of power, the cables should have a minimum wire gauge of 2.5 mm² - more for longer cabled distances. A minimum wire gauge can be easily calculated with the following formula:



Important

$$\text{Minimum Wire Gauge (mm}^2\text{)} = \frac{\text{Required Cable Length (m)}}{2 \times \text{Speaker Impedance (}\Omega\text{)}}$$

If several loudspeakers are connected, the signal can be linked through from one loudspeaker to the next. Please make sure that the total impedance of the loudspeakers R (Ω) is not lower than the minimal impedance indicated on the power amplifier.

$$1/R_1 + 1/R_2 + 1/R_3 + \dots = 1/R_{\text{total}}$$

8.1 Connecting the Speakon Connector to the Terminal

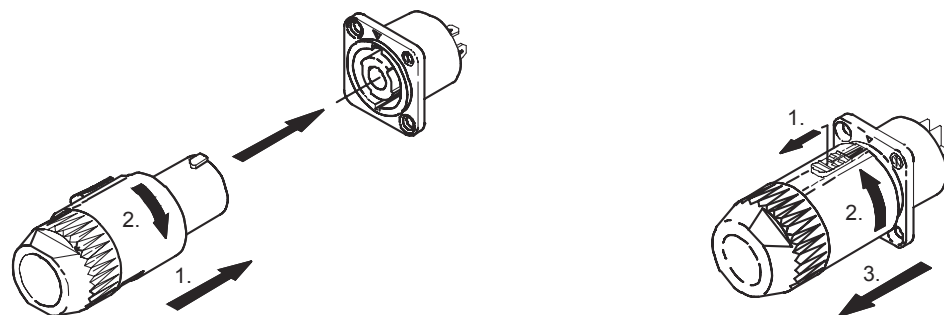

8.2 Avoiding Ground Loops

8.2.1 What is a Ground Loop?

Every component of a P.A. or Hi-Fi System has its own internal 0 V reference (ground). This point is often connected to the protective earth connector (PE / Ground). If two or more units are connected to one another with a line level audio cable, there may be a ground connection through the ground of the power supply cable (yellow-green) as well as through the shielding of the audio cable. The voltage difference between these two ground points causes audible interference to come from the speaker.

8.2.2 Avoiding Ground Loops

If there is a loud humming or buzzing after the CA 1001 System has been connected, then check that a "ground loop" has not been built into the system. Some power amplifiers and system controllers are equipped with a "Ground Lift" switch. Set these switches to the "Lift" position one after the other. If the noise is still audible, check if,

1. the noise is caused by a ground loop before the power amplifiers / controllers (e.g. mixing console, effects or equalizers).
2. the system or parts of the system are connected to an "unclean" power supply - meaning one, which is also running large motors, or lighting systems. An "unclean" supply voltage, electrostatic and electromagnetic fields can cause a malfunction.

Please observe the following basic rules:

- **Never!!! try to avoid a ground loop by disconnecting or taping the ground contact at the power connector! Extremely dangerous!**
- If possible, only use high-quality audio appliances with balanced signal outputs and with power cables with PE connectors.
- Use high-quality cables with good shielding.
- The point of ground for all connected components should merge at one central point. The power connections should lead out in a radial manner from one point and not be linked from one unit to the next.
- When installing appliances that create strong electrostatic or electromagnetic fields (large transformers, switch-mode power supplies), maintain some distance from other audio appliances. In extreme cases, the only solution is to create a completely independent "audio ground"; in other cases, it is sufficient to connect a filter in front of the audio equipment.



9. Configurations and Connecting Diagrams

9.1 Operating the Systems without C2 Controller

The CA 1001 systems can be used alone or in conjunction with a K&F subwoofer with integrated crossover (e.g. SW 112-XO / SW 115D-XO / SW 115E-XO or SW 118E-XO). In this mode of operation the integrated crossover limits the subwoofer's frequency range.

- To protect the speakers from being destroyed and to avoid fire hazard, they should only be operated with professional power amplifiers with the following specifications:
 - integrated or preceding subsonic filter (approx. 20 Hz, min. 12 dB / octave)
 - integrated clipping limiter
 - maximum rated power 500W@6 Ohms (equivalent 750W@4 Ohms)
- If you wish to use a speaker with a power amplifier which does not fulfil these specifications, then the speaker should be controlled using a Kling & Freitag System Controller with limiter function. This is the only way overloading and that the risk of fire can be avoided. The results of such a power amplifier defect of cannot be avoided by the controller.



9.1.1 CA 1001 Systems in Full-Range Mode

This mode of operation is ideal for speech applications and music applications without the need for a high bass content. Should more bass be needed, the bass level can be increased between 50 and 80 Hz at the mixing console.

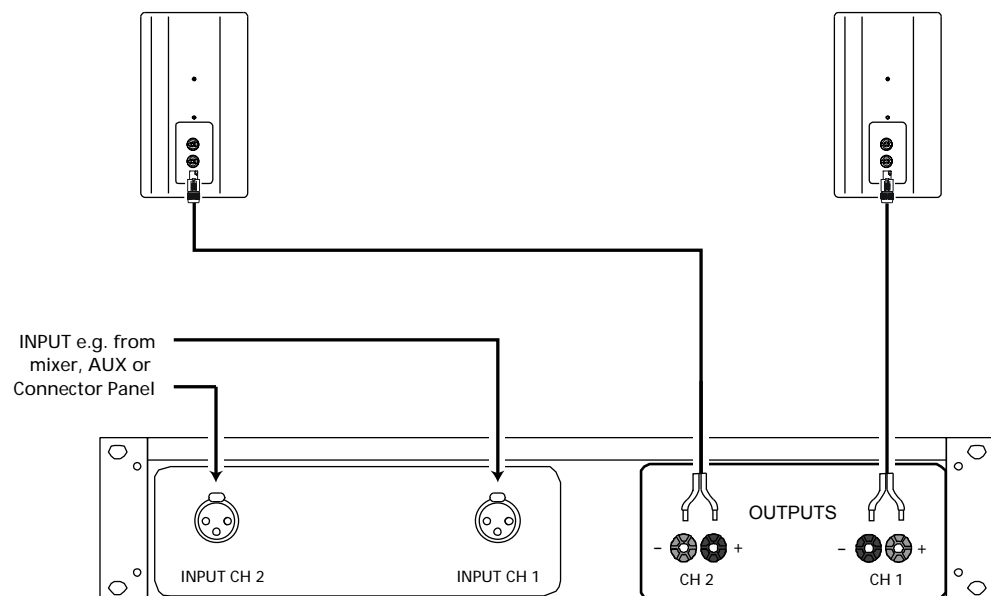

If you are operating CA 1001 systems in a cluster (speakers arranged in close proximity) or as a stage monitor, reduce the frequencies below 300 Hz by 3-4 dB! (The K&F C2 Controller has special filter for this purpose, which can be activated with the 'Top Low Cut' switch.)

9.1.2 Full-Range Mode & Subwoofer with Crossover (XO)

In this mode of operation you can easily realise applications, where a higher bass level is needed.

In this mode of operation be sure to use only amplifiers, which can handle speaker impedances down to 3 Ω.

Recommended combinations of CA 1001 systems with K&F subwoofers in 2-way passive mode:

- 2 x CA 1001 with 2 x SW(i) 112
- or 2 x SW(i) 115D - XO
- or 2 x SW(i) 115E - XO
- or 2 x SW(i) 118E - XO

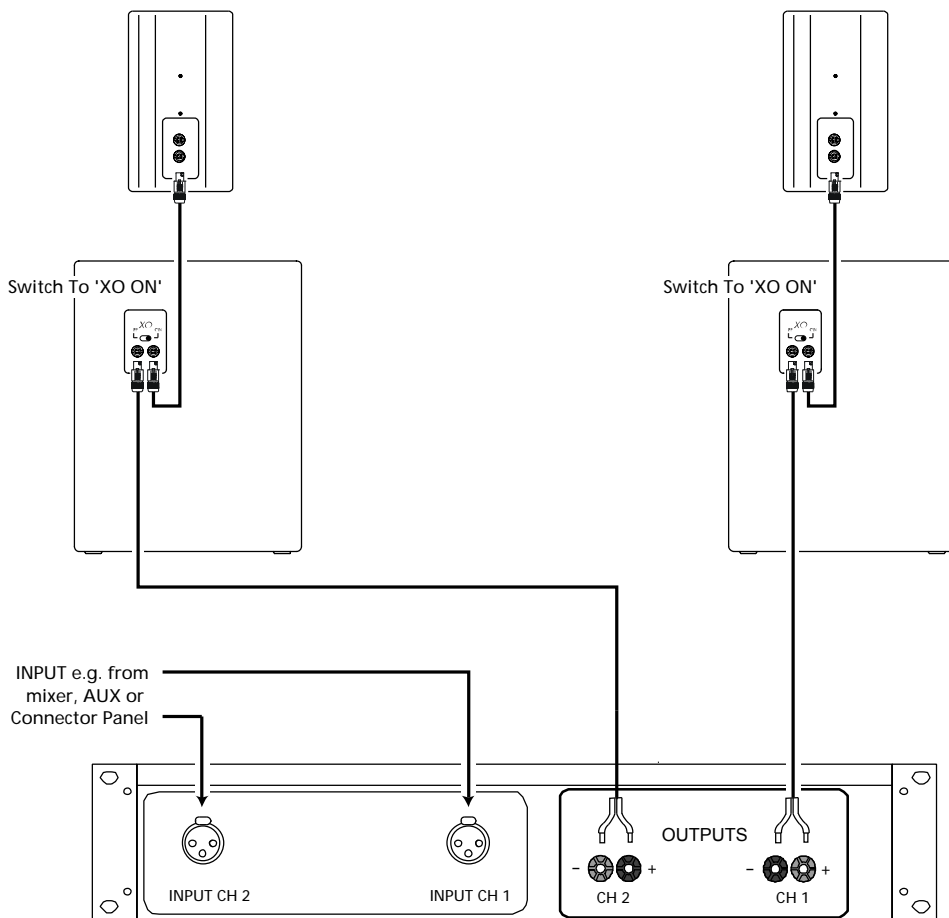

The switch 'XO' on the connecting terminal of the subwoofer with integrated crossover must be at 'XO ON' for this mode of operation:

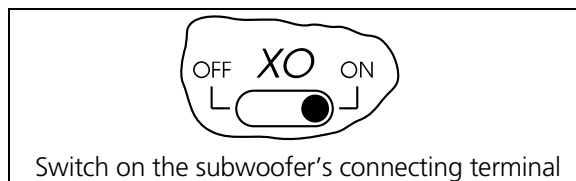

When using the CA 1001 systems in a cluster (speakers in close proximity), reduce the frequencies below 300 Hz by 3-4 dB. (The K&F C2 Controller is equipped with a special filter for this purpose, which can be activated by pressing the "Top-Low Cut" switch)

9.2 Operations with C2 Controller

By using carefully adjusted filters (EQ) on special system cards for the CA systems, the C2 Controller optimises feedback prevention and the frequency response of the speakers.

The controller provides optional bass boost in full-range mode, optimisation for cluster operation (Top Low Cut switch), high boost and sub-mono functions.

The C2 Controller optimises the operating safety of the speakers and power amplifiers by using special peak and RMS limiters in Sense Technology:

With other (universal) controllers, the gain of the selected power amplifiers must be known. The limiter on the C2 Controller, on the other hand, uses a special control circuit to determine the actual output voltage of the power amplifiers. The limiter then reduces the input level only when the power amplifier actually provides more power than the speakers can handle. The amplifier's gain and the position of the input level control for the power amplifiers are insignificant for the limiter function of the C2 Controller.

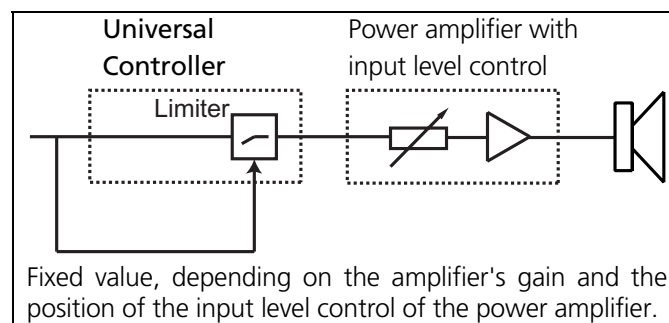
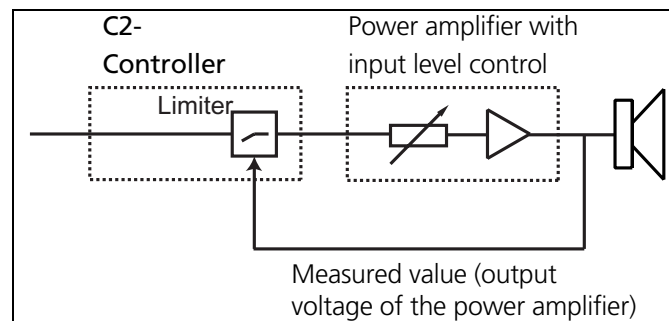

9.2.1 Full-Range Mode with K&F C2 Controller

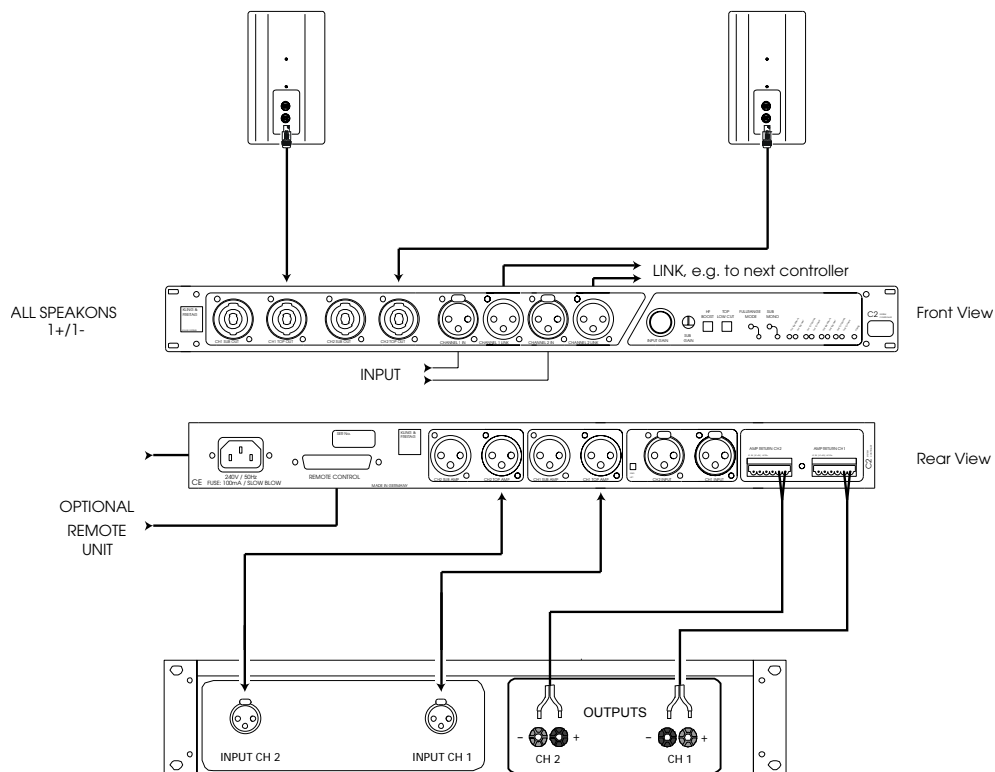

The countersunk switch 'Full-Range Mode' on the C2 Controller should be pressed and the LED assigned to it should light up. The full-range switch accentuates the bass frequencies of the mid-high systems, giving a more balanced sound to music programmes.

When using CA 1001 systems in a cluster (speakers in close proximity) or as a stage monitor, activate the "Top Low Cut" switch on the C2 Controller.

9.2.2 CA 1001 & Bass with Controller C2 in 2-Way Active Mode

Recommended combinations of CA 1001 systems with K&F subwoofers in 2-way active mode with C2 Controller:

- 2 x CA 1001 via C2 Controller with 2 x SW(i) 112 or 2 x SW(i) 115D - XO
- or 2 x SW(i) 115E - XO or 2 x SW(i) 118E - XO
- or 1- 2 x SW 215E or 1- 2 x ACCESS B5

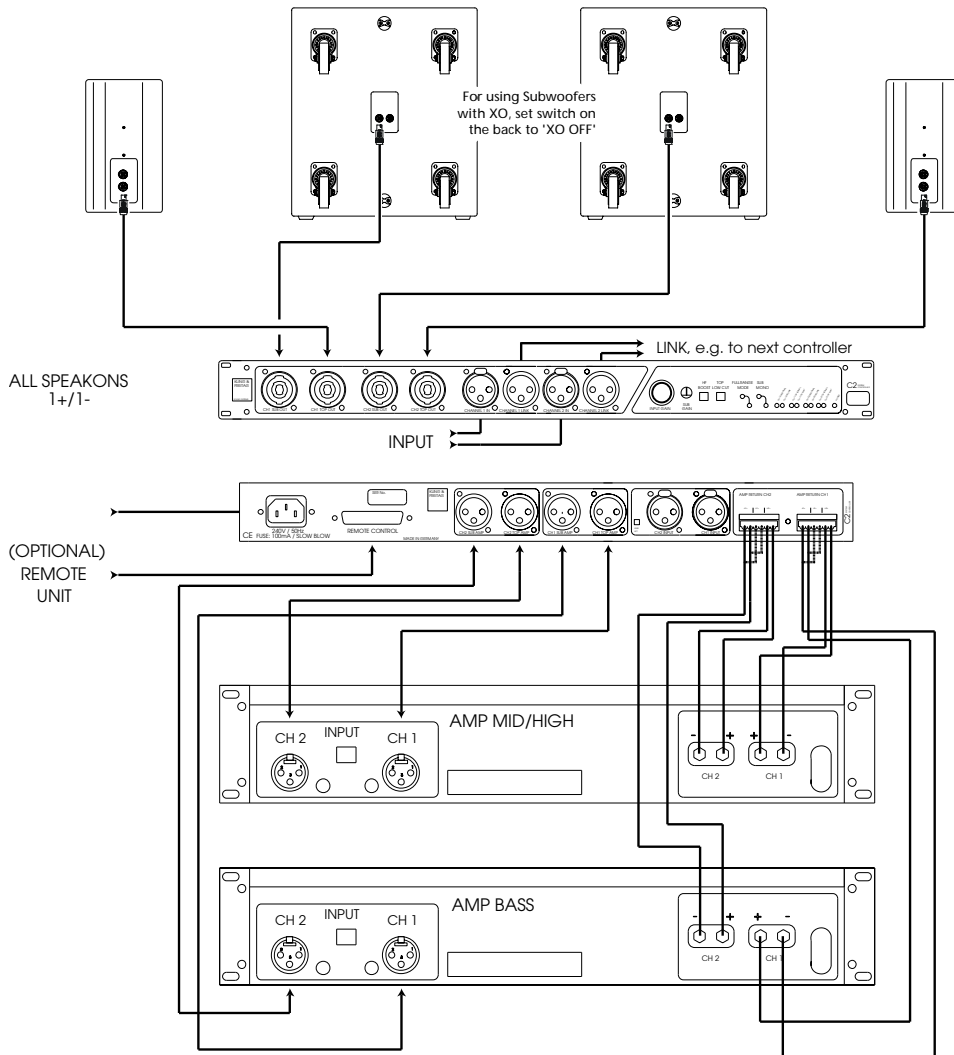

The switch "XO" on the connecting terminal of the subwoofer with integrated cross-over must be at "OFF" for this mode of operation:

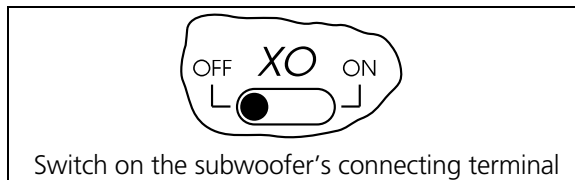

Note for full-range mode:

The countersunk switch 'Full-Range Mode' on the C2 Controller should not be pressed and the LED assigned to it should not light up.

Note for clustered speakers:

When using the mid-high systems in a cluster (speakers in close proximity), activate the "Top Low Cut" switch on the C2 Controller.

10. Operating the Speakers

- Switch off all equipment and turn down all level controls.
- Wire the CA 1001 systems according to the wiring diagrams as shown before.
- Upon completing the wiring, ensure that the connected speaker channels are working in phase. To do so, use i.e. a phase checker. A phase error can also be recognized when the connected channels are used simultaneously. During simultaneous use the bass frequencies become notably quieter or the mid-frequencies such as voices cannot be located.
- Now switch on the peripheral equipment first (mixing console, effects etc.), followed by the C2 Controller, if used, and the power amplifiers. Always use the before mentioned switching order. Otherwise switching noises may damage the system.
- If there is interference, turn off all appliances in the reverse order and check all cable connections (see chapter 8.2).
- Next, turn on the C2 Controller, if used, and the other peripheral equipment and make sure there is no interference
- Now put a low level signal into the system and check for the correct function of the system. In doing so, all amplifier input controls need to be turned off again. Now turn on the control for the left CA 1001 system and check that the correct signal is coming out of the CA 1001 system.
- With C2 Controller: The Sense LED for the top speaker (i.e. CH 1 TOP signal) of the C2 Controller will light up green at a level of at ca. -40dB. The other channels of the system are checked in the same way. If the wrong LED lights up or a wrong (i.e., in 2-way active mode, low signal from a high frequency speaker) or distorted signal occurs, then there is a mistake in the wiring.
- Your system should now be ready for operation.
- Turning down the input level controls may not always prevent distortions in the input section of the power amplifier, especially if this section has a relatively low headroom. A clipping signal may not be displayed by the clipping indicator then. To prevent signal interruptions or damages to the speakers, turn the level controls of the power amplifier to the maximum position, if possible. The output level of the mixing console or the controller should be set to a level that doesn't overload the power amplifiers.
- When turning off the system, the input controls for the power amplifiers should be turned down first followed by the power switches of the amplifiers. After that, the other appliances can be turned off.
- The crossovers of the CA 1001 systems are equipped with protection circuits for the high frequency driver and the crossover itself. These circuits cut off the signal current when highly overloaded. If the high speaker turns off, reduce the volume. After a few seconds, it will turn back on automatically.



Important

11. Crossovers: Wiring Diagram CA 1001

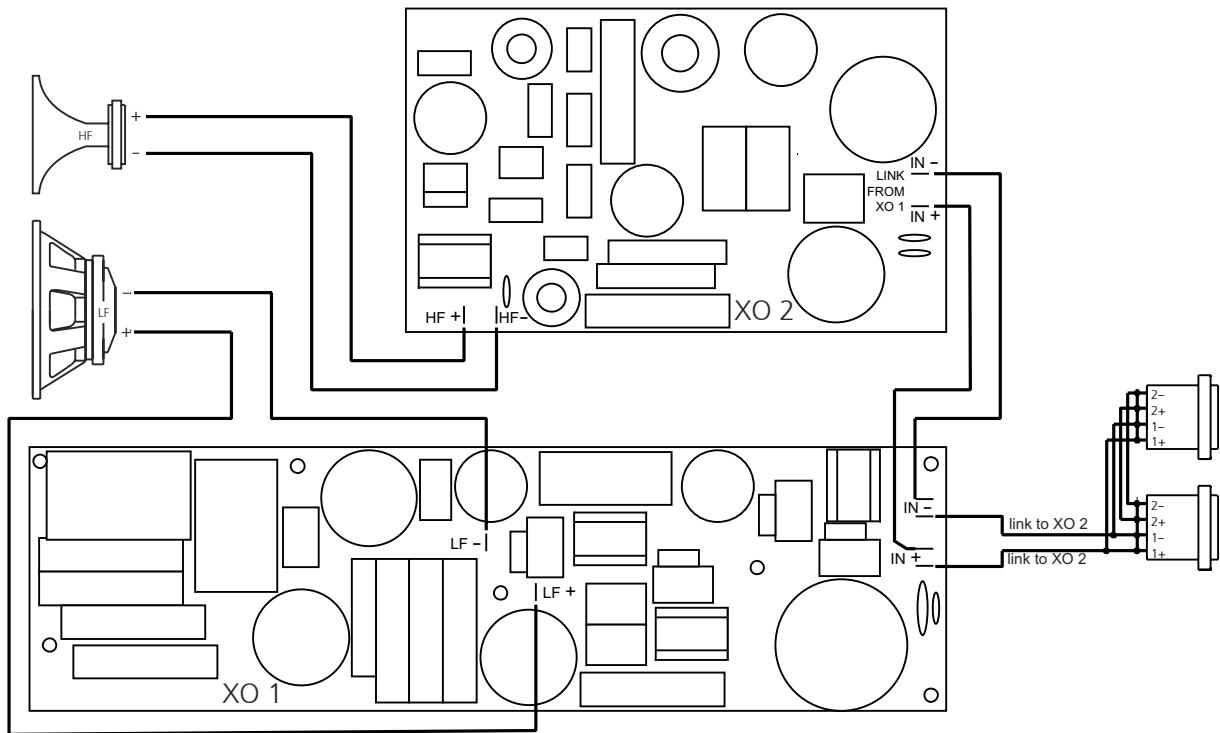

Pin assignment Speakon NL4				
	+	-	/	/
'IN'	1+	1-	2+	2-
'OUT'	parallel with 'IN'			

12. Touching Up Damage to Paint / Changing the Front Foam

Although the PU structured paint used by KLING & FREITAG is impact proof and extremely resistant, we recommend using protective coverings or cases to help avoid damaging the paint during i.e. continuous mobile use. If paint damage occurs despite these precautions, it can be touched up by using commercial acrylic paint in the appropriate RAL colour of the speaker.

To replace the filter foam, send the front grille incl. foam to KLING & FREITAG GmbH. Upon payment for expenses, the grille with the new covering will be returned.

13. Technical Specifications CA 1001

Loudspeaker	
Design	2-way passive system, bass reflex tuning
Frequency range -10 dB	53 Hz - 20 kHz
Frequency range ± 3 dB	82 Hz - 19 kHz
Coverage angles (nominal)	85° x 55° (hor. x vert.)
Directivity index (DI)	10 (+1.5/-1) 1.2 kHz - 14 kHz
Power handling	250 W nominal 500 W programme
SPL 2.83 V / 1m	96 dB
Max. SPL	124 dB (SPL Peak / 1 m)
Components	10" low-mid chassis 1" high freq. driver with 45 mm titanium dome on rotatable CD-horn
Crossover	2-way crossover with delay time and phase correction, self-resetting protection circuits for low-mid and high frequency chassis
Impedance (nominal)	6 Ω , Zmin. 4.8 Ω
Connectors	2 x Speakon NL4MP (1+ / 1-)
Enclosure	
	Multi-functional enclosure with monitor and cluster angle, 12 mm Finnish birch Multiplex with highly resistant black or white structured paint (PU) 5 x M 10 and 2 x M 8 thread inserts, ball proof front grille with exchangeable black or grey (white) acoustic foam
Dimensions (W x H x D)	313 x 520 x 306 mm
Weight	18.3 kg
Options	'100 Volt with 300 VA toroidal transformer (8.7 kg)' 'Terminal clamp' instead of Speakon connector, 'Outdoor Mobile' 'Special finish in RAL colours'
Accessories	see catalogue or visit www.kling-freitag.de

14. Measuring Charts

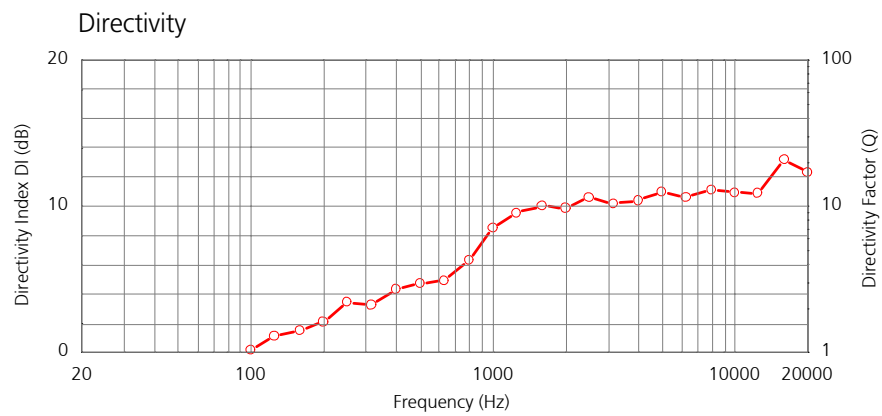
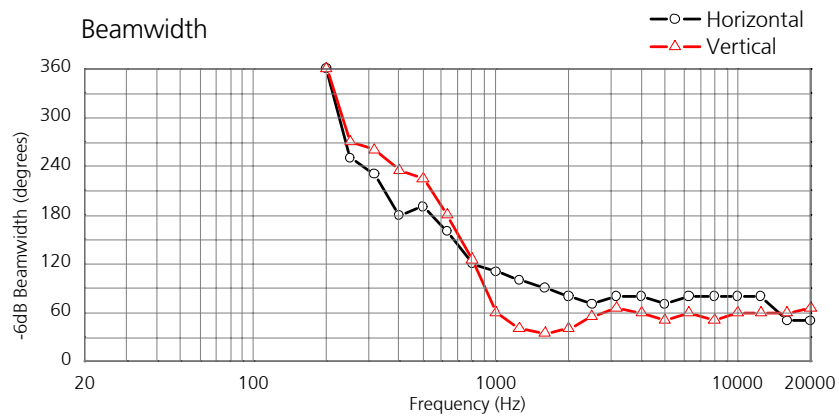
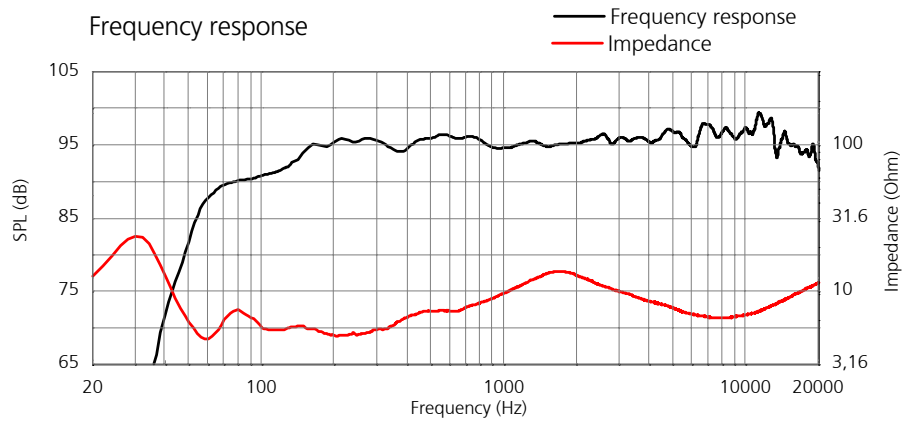

Horizontal coverage

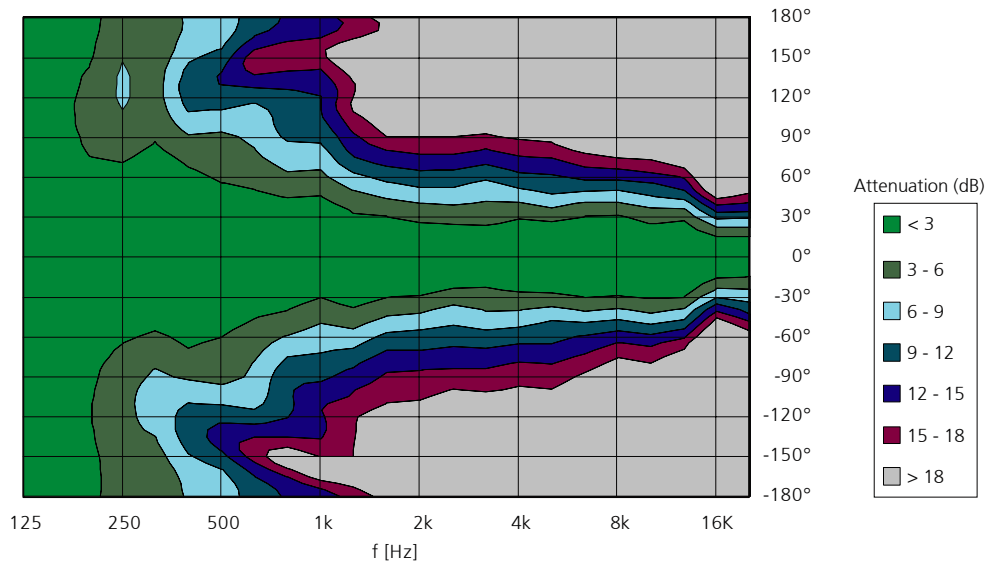

Vertical coverage

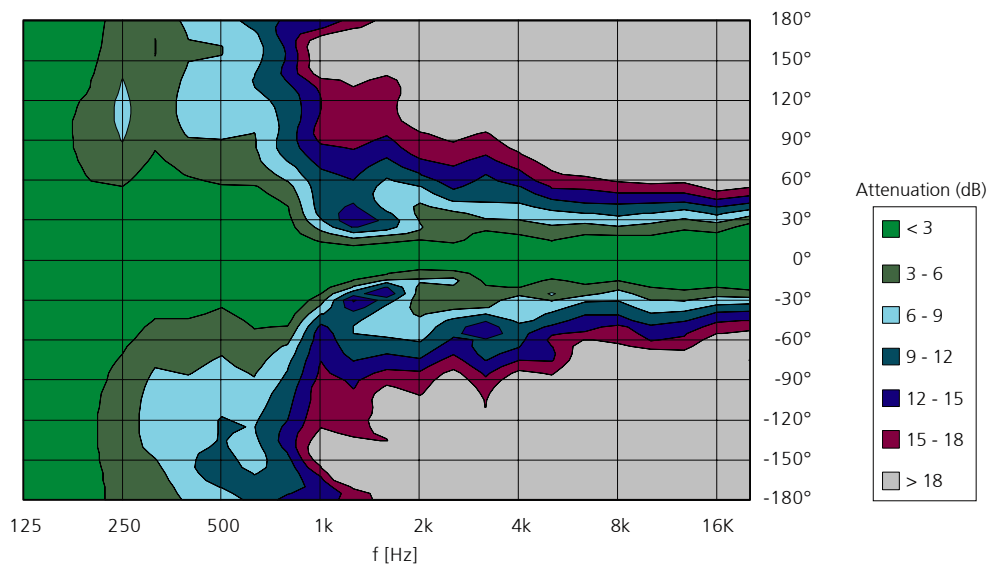

15. Dimensions

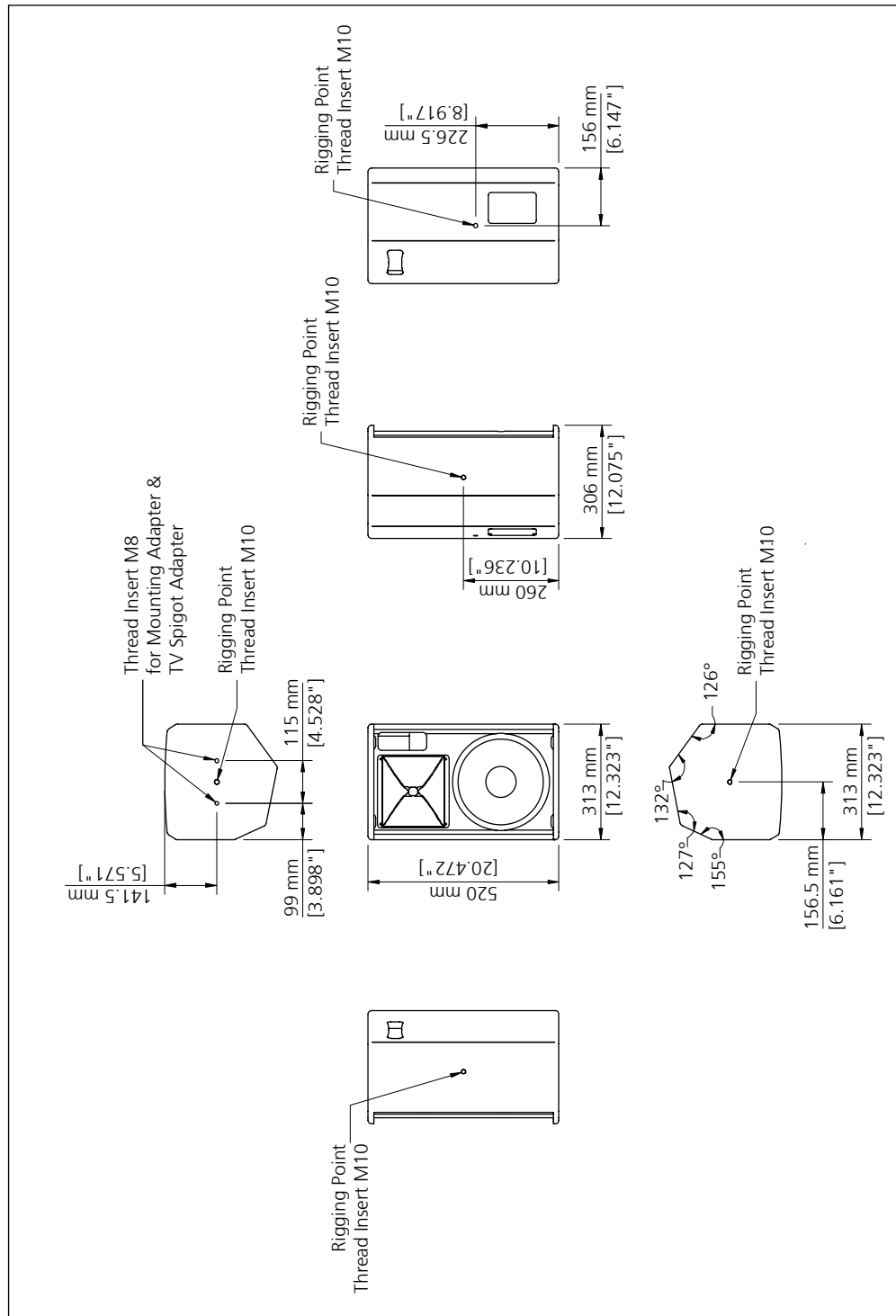

16. Accessories

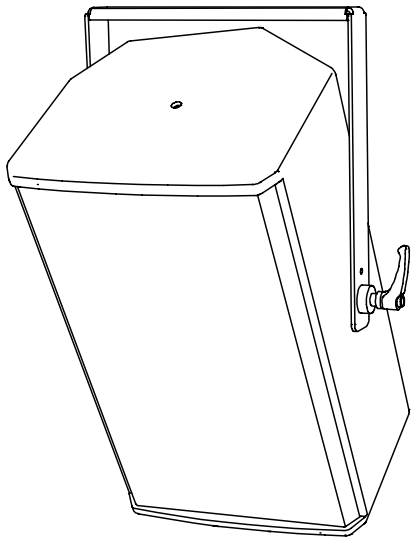

Adjustable speaker mount CA 1001 with undetachable clamping levers

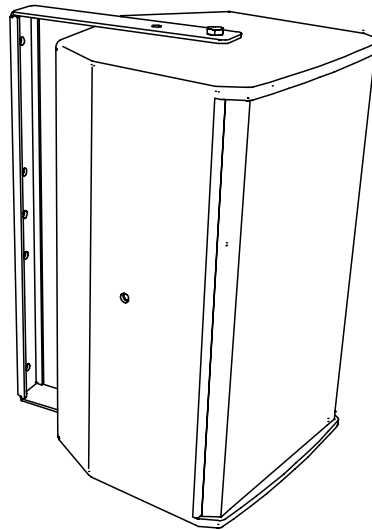

U-mount wall / ceiling bracket CA 1001

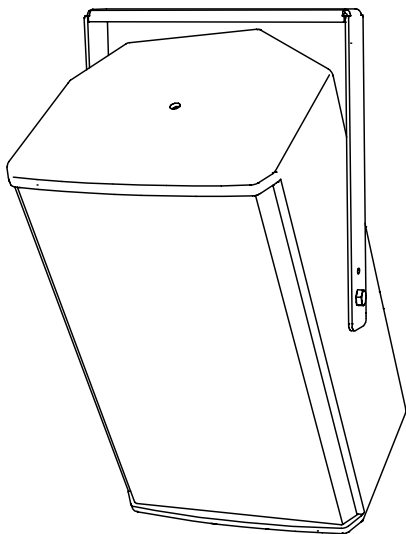

Adjustable speaker mount 'Installation' CA 1001

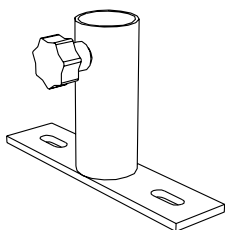

Mounting adapter

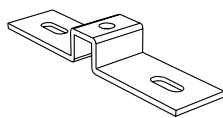

TV-spigot adapter



TV style clamp



TV-spigot



Eyebolt M8 x 20

Further information is available in our downloadable catalogue at:
www.kling-freitag.de

17. Regulations for Disposal

17.1 Germany:

It is not allowed to dispose of used electrical equipment as domestic waste.

But please do not dispose of them at official collecting points for recycling either!

All Kling & Freitag products are plain business-to-business (B2B) products. Disposal of Kling & Freitag products labelled with a waste bin sign have thus to be disposed of by Kling & Freitag alone. Please call Kling & Freitag at the number stated below if you have a Kling & Freitag product to be disposed. We will offer you a straightforward and professional disposal not affecting costs.

If there is no dustbin sign on one of your Kling & Freitag products, because they have been sold before March 2006 then by law the owner is in charge of the disposal. For these we will be happy to assist and offer you proper ways of disposal.

**Telephone number to call about the disposal of used Kling & Freitag products:
+49 (511)-96 99 7-0**

Explanation:

With the ElektroG (law relating to electrical and electronic equipment and appliances) we have complied with the EU-directive on waste electrical and electronic equipment (WEEE, 2002/96/EC)

The Kling & Freitag AG has thus labelled all products mentioned in the WEEE from 03/24/2006 onwards with a sign with a crossed out waste bin and a white bar below. This sign indicates that the disposal into the domestic waste is prohibited and that the product has been put into circulation at the 03/24/2006 earliest.

The Kling & Freitag GmbH has been legally registered as a manufacturer with the registration office EAR. Our WEEE Registration-Nr. is: DE64110372

For the German Registration office EAR we have accredited that our products are sole B2B products.

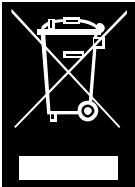

17.2 EU, Norway, Island, and Liechtenstein (not Germany):

It is not allowed to dispose of used electrical equipment as domestic waste.

The Kling & Freitag AG has thus labelled all products coming from EU-Member countries as well as Norway, Island and Liechtenstein (except Germany) mentioned in the WEEE from 08/13/2005 onwards with a sign with a crossed out waste bin and a white bar below. This sign indicates that the disposal into the domestic waste is prohibited and that the product has been put into circulation at the 08/13/2005 earliest.

Unfortunately the European directive WEEE has been complied with implementing different national provisions of law throughout all member countries, which makes it impossible for us to offer consistent solutions for the disposal throughout Europe.

Responsible for complying with these provisions of law is the local distributor (importer) of each country.

For proper disposition of used products in accordance with these local provisions in the mentioned countries of the European Union (except Germany) please ask your local dealer or the local authorities.

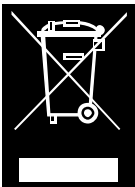

17.3 Other countries

For proper disposition of used products in accordance with local provisions in other countries please ask your local dealer or the local authorities.