

*Since 1964, the leader in effective, safe and reliable products for fisheries conservation.
Knowledgeable biologists depend upon Smith-Root equipment.*

USER'S MANUAL

GPP 2.5, 5.0, 7.5 & 9.0

Portable Electrofishers (W/Kohler/Honda/Generators)

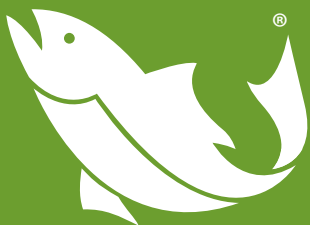

SMITH-ROOT

Products for Fisheries Conservation

07290.11

CONTENTS

INTRODUCTION	3
Unpacking	4
Choosing a Location.....	4
Fuel Shut-Off Valve	5
Power Supply Controls	5
Operating Procedure	8
Maintenance	9
Electrofisher Controls.....	6
Gpp Display	7
Basic Troubleshooting.....	10
Specifications	11
Parts List.....	12
Fan Installation Kit/ Engine Anti-Vibration.....	13
Generator Anti-Vibration Mounting	14
Contents: Electrofishing Safety & Principles	16

SAFETY

Electrofishing Safety.....	17
Backpack Safety.....	18
Boat Safety	18
Do's & Don'ts	18
Introduction to Electrofishing	19
Types of Current.....	21
Electrode Design.....	22
Field Techniques.....	25
References	26

APPENDIX: Advanced Troubleshooting

Check Generator 12 AC Voltages (all models) ..	28
Test for Continuity, High Voltage AC Output	29
Check connections, brushes, exciter rectifier	30
Check Rotor Windings	31
Check Stator Windings.....	32
Test GPP Control Box	33
Test GPP Control Box	34
Flashing the Rotor	35
Build a Test Load.....	36
2.5 & 5.0 GPP Generator Stator Wiring	37
7.5 GPP Generator Stator Wiring	38
9.0 GPP Generator Stator Wiring	39

Items manufactured by companies other than Smith-Root carry the original manufactures warranty. Please contact product manufacturer for return instructions.

All Smith-Root, Inc. manufactured products are covered by a one year warranty.

GPP ELECTROFISHER USER'S MANUAL

2.5 / 5.0 / 7.5 / 9.0 GPP Combo Package Includes the Following:

Model	Qty	Description	Line Number
2.5 GPP	1	2.5 GPP Control Box	3418
	1	2.5 GPP Generator	4664
	1	Output Cable	3415
	1	Single Foot Switch w/15 ft. Cable & Plug	3309
	2	Electrofisher Certification	5465
5.0 GPP	1	5.0 GPP Control Box	3420
	1	5.0 GPP Generator	4666
	1	Output Cable	3415
	1	Single Foot Switch w/15 ft. Cable & Plug	3309
	2	Electrofisher Certification	5465
7.5 GPP	1	7.5 GPP Control Box	3421
	1	7.5 GPP Generator	4667
	1	Single Foot Switch w/15 ft. Cable & Plug	3309
	1	7.5 GPP Cathode Cable	3416
	2	7.5 GPP Anode Cables	2962
	2	Electrofisher Certification	5465
9.0 GPP	1	9.0 GPP Control Box	3867
	1	9.0 GPP Generator	4668
	1	Single Foot Switch w/15 ft. Cable & Plug	3309
	1	9.0 GPP Cathode Cable	6050
	2	9.0 GPP Anode Cables	7976
	2	Electrofisher Certification	5465



INTRODUCTION

Smith-Root Generator Powered Pulsator (GPP) electrofishers are unsurpassed in quality and performance. Our years of experience in manufacturing electrofishers has helped us to produce the most complete line of generator powered electrofishers ever offered. Ranging from 1.5 to 9kW, Smith-Root manufactures electrofishers to handle all fresh or brackish water conductivities.

A complete electrofishing system consists of an engine, a generator, an electronic pulsator, an anode, a cathode, cables, and switches.

Our GPP generators are custom-wound to supply the optimum voltages for electrofishing, and eliminate bulky and hot power transformers.

All electrofisher pulsators are supplied in an aluminum case with carry handles.

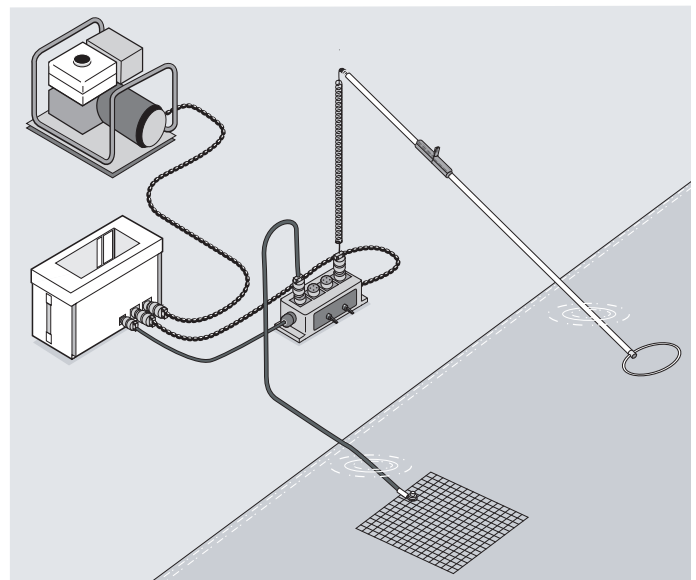

A typical shore hook-up with electrode pole and control box.

GPP ELECTROFISHER USER'S MANUAL

UNPACKING & SET-UP

UNPACKING

Carefully remove the GPP and its power supply from the shipping container and examine closely for shipping damage. If any parts are missing or the unit is damaged, notify the transportation company and immediately file a claim for the amount of damage. Record the model and serial number of your electrofisher in the spaces provided below:

Model Number _____

Serial Number _____

When ordering parts, always include the power supply model and serial number located on the unit's nameplate. This is essential to ensure the correct replacement part is shipped to you. Please keep this manual and refer to it when making adjustments or ordering parts. Additional copies are available for a nominal charge from your distributor.

CHOOSING A LOCATION

In choosing the best location for your GPP, the following factors should be taken into consideration:

FIRE HAZARDS: Locate the power supply at least 3 feet (1 meter) away from buildings or structures. Keep the power supply away from flammable trash, rags, lubricants, and explosives. Do not use the power supply near any forest, brush, or grassland unless the exhaust system is equipped with a spark arrestor that is effective. Have a fire extinguisher accessible.

SECURITY: Choose a location where everyone, especially children, can be kept away, to protect them from burns and electrical shocks. Take precautions to prevent unqualified personnel from tampering with or attempting to operate the power supply.

SURFACE: Choose a level surface. If the power supply is tilted, fuel spillage may result.

MOISTURE: Do not stand the unit in water or on wet ground. Protect electrical equipment from excessive moisture that will cause deterioration of the insulation and may result in short circuits.

DIRT: Install the unit in a clean location. Abrasive materials such as dust, sand, or lint cause excessive wear to both engine parts and generator parts. Grass and leaves are a fire hazard.

COLD: Engines should be located where the temperature does not fall below freezing. Engines start easiest when they are not subject to extreme cold.

HEAT: The temperature of the area where the engine is located must not exceed 100°F because the engine is air-cooled. Where natural ventilation is inadequate install a fan to boost circulation.

CONFINED SPACE: Restricted air flow can cause overheating and damage the engine and generator. Operation in an enclosed compartment is also a fire hazard and is not authorized.

EXHAUST: Whenever an engine is used indoors, the exhaust must be vented to the outside. Exhaust from a gas engine is extremely poisonous, containing carbon monoxide, an invisible odorless gas that can cause unconsciousness or death.

AUXILIARY WIRING: Use sufficiently thick insulated wire to hook up to the auxiliary windings. The gauge depends on the length of the wire, the voltage drop, and the amount and kind of load. Consult a competent electrician and national and local codes.

GROUNDING: If grounding is called for in local codes, or radio interference necessitates it, drive a 3/4 or 1 inch pipe into the ground as close to the unit as possible. This pipe must penetrate moist earth. To the pipe connect a ground clamp and run a No.10 wire from it to the battery negative terminal on the control panel, or to the generator ground stud. Do not connect to a water pipe or a ground used by a radio system. When used in boats, ensure that generator frame is grounded to boat hull. This will prevent a shock in the event of an electrical failure.

FUEL SHUT-OFF VALVE

The generator has one fuel shut-off valve. Make sure the valve is open for proper operation. It is located directly below the choke lever.



POWER SUPPLY CONTROLS

GENERATOR: Your GPP is powered by a specially manufactured gas-powered generator. The generator is wound so that the output voltages are taken directly from the generator, eliminating the need for a transformer or voltage-doubler. The generator has a self-excited revolving field. This rotor connects directly to the engine crankshaft with a tapered fit. The stationary Stator has a separate excitation winding, and multiple windings to supply AC power.

12 VAC: terminals on the generator provide up to 500 watts of 12 volts AC power on each circuit. This will run 12 volt lights, or with an external rectifier will recharge batteries. The 5.0, 7.5 and 9.0 GPP have two output circuits.

ENGINE: This instruction book covers mainly the electrofisher and the generator, but not the engine. Please read all instructions in the engine manufacturer's manual. The engine manufacturer has established an excellent worldwide service organization. Engine service is probably available from an authorized engine dealer near you: check your Yellow Pages.

ENGINE GOVERNOR: The engine must be run at 3600 rpm to supply the power it was designed to produce. The governor on the engine holds the speed as nearly constant as possible. The governor is set at the proper speed in the factory. Do not adjust the governor without proper tools.

VOLTAGE VARIATION: All engines slow down when a load is applied. When the electrical load on the generator is increased, the engine speed drops. This results in a lower voltage when the generator is loaded to its full capacity than when running unloaded.

FREQUENCY VARIATION: The AC frequency is around 60 cycles per second. The inevitable variations in engine speed produce slight variations in the AC frequency. This has no noticeable effect on the operation of motors, lights, and most appliances. However clocks and other timing devices and will not keep perfect time when used on generators.

MODIFICATIONS to the power supply that are not Smith-Root authorized may impair the function and safety of the unit.

Relative positions of input, output and control plugs on 2.5-5.0, 7.5 and 9.0 GPPs

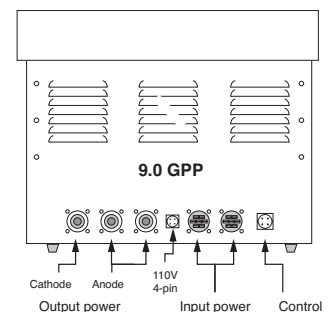
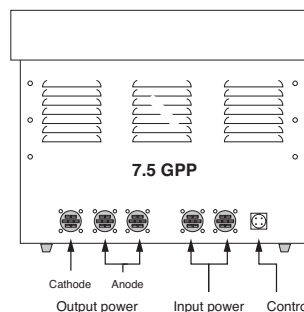
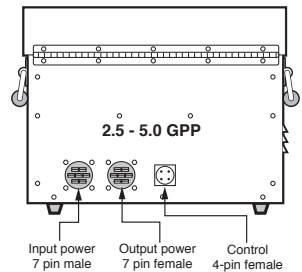

GPP ELECTROFISHER USER'S MANUAL

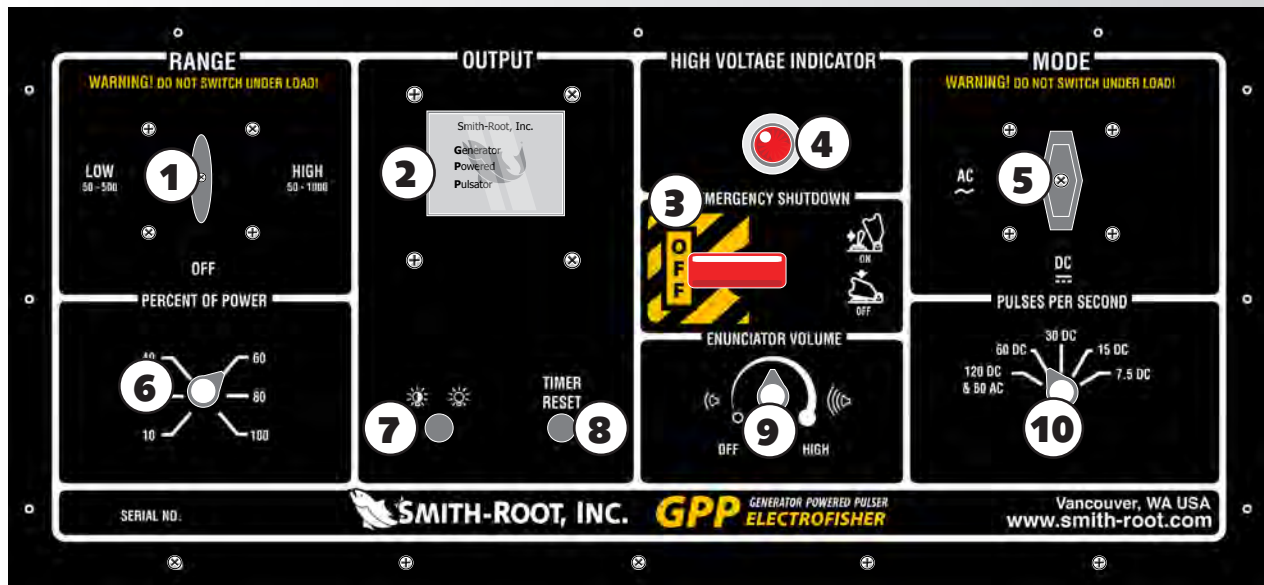

Control Panel

ELECTROFISHER CONTROLS

- 1 - RANGE SWITCH:** Selects the output voltage range between high and low or switches the output to OFF. Use low range setting for high conductivity water and high range setting for low conductivity water. **⚠ DANGER!: The position of this switch should not be changed when the current is flowing, i.e: when foot switch is engaged.**
- 2 - OUTPUT DISPLAY:** Displays all output setting parameters, duration, fault conditions.
- 3 - EMERGENCY SHUTDOWN SWITCH:** Shuts down operation of the GPP and provides a local override of remote foot switches.
- 4 - HIGH VOLTAGE INDICATOR:** Red indicator lamp shows when voltage is present on output power terminals.
- 5 - MODE SWITCH:** Selects the type of output pulses, AC, DC or OFF (7.5 only) (Caution!: The position of this switch should not be changed when current is flowing i.e. foot switches engaged!).
- 6 - PERCENT OF POWER SWITCH:** Allows the operator to smoothly vary the output voltage and pulse width simultaneously, following the positive half of a sine wave.
- 7 - DISPLAY MODE:** Switches display readout between Day/Night backlight/contrast modes.
- 8 - TIMER RESET:** Resets GPP interval timer to zero.
- 9 - ANNUNCIATOR VOLUME:** Controls the volume of the audio output warning signal.
- 10 - PULSES PER SECOND:** Selects the frequency of pulses in the output wave form.

GPP DISPLAY

On power-up, the unit displays the splash screen with a gray SRI fish logo.

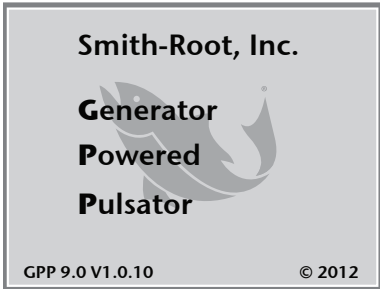

Startup/splash screen

The splash screen also displays the GPP model number and firmware version number.

	Peak	Average
Voltage	4v	2v
Current	0.1A	0.1A
Power	0w	0w
Frequency		120Hz
Duty Cycle		0%
Time (Sec)		1097

Typical Status Screen

If no switch is active, the splash screen is replaced, after a few seconds, with a status screen.

The status screen displays the numeric value for peak and average of voltage, current and power. It also shows the pulse frequency and, when the unit is active, the percent duty cycle.

The time in seconds that the unit has been active is also displayed on the status screen. This time is cumulative and the value is retained through power cycles. It can be reset to zero by depressing the "Timer Reset" button.

The GPP constantly takes voltage and current readings and displays these on the status screen. In addition the GPP compares it's current readings with safety limits specifically for the model in use. If the current readings exceed a low limit the GPP will flash a "Warning" message on the screen but continue to operate. If the GPP's current readings exceeds a higher limit the GPP will display a "ERROR" message on the screen and stop the output to prevent damage to the system. Releasing the Foot switch will remove the error display and restore the status display screen.

The status screen has two modes: A brighter daylight mode and a contrasting night mode. The same information is present in both modes. Pressing the "Display Dimmer" button will toggle through the two status display modes



Display in "Night" mode.



A: Daylight/Night mode selector B: Timer reset button

FAULT MENUS

The display system also shows various fault conditions and other warning dialogs, with possible solutions.

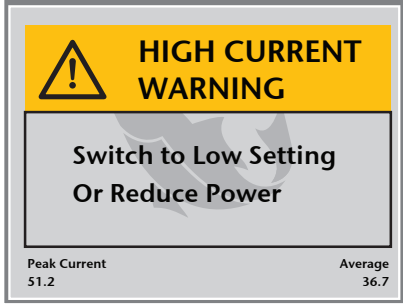

High Current Warning dialog

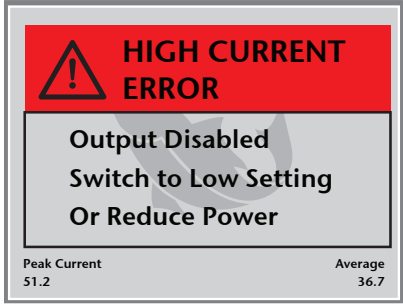

High Current Error dialog



Switch Active At Reset dialog



Zero-Cross Timing Error dialog

GPP ELECTROFISHER USER'S MANUAL

OPERATING PROCEDURE

Before operating the power supply put on safety glasses and ear protectors. Remove wristwatch, rings and any other jewelry. Do not operate the power supply while smoking. Do not operate while under the influence of alcohol, drugs or medication.

1. First, check the engine oil level. Use 4-stroke automotive detergent oil SAE 10W-30. Do not overfill.
2. Refuel the engine outdoors. Keep away from any open flame, pilot light, furnace, heater, or clothes dryer. Stop the engine and allow it to cool prior to refueling. Never fuel the engine while it is hot or running to avoid fire, explosion, bodily injury, or property damage.
3. Use gas with a minimum rating of 85 octane. Do not use leaded gas because it produces combustion deposits that may shorten the life of the exhaust system. Do not mix oil with the gasoline. Use a clean, properly marked and approved safety container for storing fuel.
4. Fill the gasoline tank with clean fresh unleaded gasoline. Do not overfill the tank. Leave half an inch of the top of the tank to allow space for expansion. Make sure the fuel cap is tightly closed.
5. If fuel was spilled, wipe it away carefully. Wait until the fuel has dried before starting the engine.
6. Connect the Anode and Cathode to the OUTPUT PWR receptacle/s
7. Plug the remote control cable (foot switch) into the 4-pin receptacle.
8. Attach the generator cable/s into the male plug/s labeled INPUT PWR.
9. Place the anode and cathode in the water, not touching each other.
10. Fully choke the motor to start. Open the choke once the engine is running. Do not touch high-voltage spark plug and coil terminals. While spark voltages are not normally lethal, the involuntary jerk of the hands caused by electrical shock may result in injury.
11. On the Electrofisher set the MODE selector switch to the desired mode. If you are not sure which mode you desire, start with 120 pps DC.
12. Set the PERCENT OF RANGE to the minimum.
13. Set the RANGE selector switch to LOW.
14. Set EMERGENCY SHUTDOWN switch to ON

Shore Hookup with Anode Poles*

*Not applicable to 7.5 or 9.0 GPPs

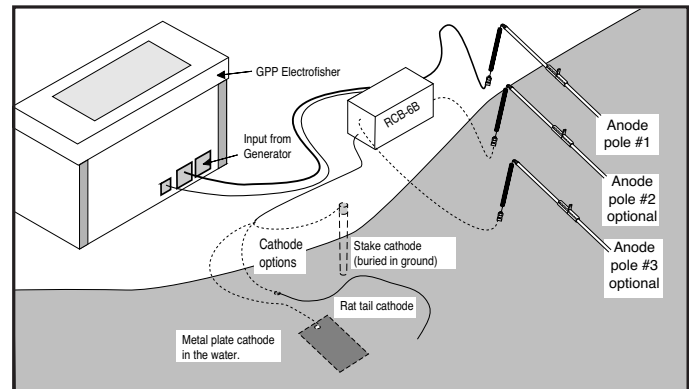

15. Set the ENUNCIATOR VOLUME to midrange.
16. Activate the remote control switch. The high voltage indicator lamp and audio alarm should both come on and the ammeter will deflect. Adjust the PERCENT OF POWER control to achieve optimum response by the fish. The duty cycle value will follow the percent of power adjustment and the peak readings will rise until the pulse encompasses the highest part of the generator power wave.
17. Deactivate the REMOTE CONTROL SWITCH. Damage to the range selector switch may result from switching under load. Experimentation will be required to learn what mode and voltage settings are best for various water conditions and types of fish.
18. If the ammeter shows LOW RANGE and the RANGE selector is in the HIGH position, switch to the LOW position. The low voltage windings on the generator are capable of delivering more current than the high voltage windings. If erratic operation occurs in the high range, switch to the low range. Do not operate the generator above the power ranges indicated on the meter, or possible engine and generator damage may occur.
19. If you have a 7.5 or 9.0 GPP, and have been running it hard, run it for another five minutes under no load before shutting it down. This allows the electrical components to cool-down slowly, extending their life considerably.
20. To avoid burns or fires let the power supply cool before transporting. When transporting, turn the fuel valve to the OFF position and keep the engine horizontal to prevent fuel spillage. When the power supply is transported over a long distance or on rough roads, drain the fuel from the fuel tank. Do not support the power supply from the top of the frame for any extended period of time.

MAINTENANCE

Before cleaning or inspecting make certain all moving parts have stopped. Disconnect the spark plug wire and keep the wire away from the plug to prevent accidental starting. Do not put hands, feet, tools or other objects near rotating parts. Always wear eye protection.

1. CHANGE ENGINE OIL after first five hours of operation. Thereafter, change oil every 25 hours of operation. Use 4-stroke automotive detergent oil SAE 10W-30 .
2. SERVICE AIR CLEANER. Clean and re-oil the pre-cleaner at three month intervals, or every 25 hours, whichever occurs first. Remove paper cartridge yearly, or every 100 hours, whichever occurs first and clean by tapping gently on a flat surface. Replace if very dirty. Keep hands and face away from the carburetor when the air cleaner is removed. A sudden backfire can cause serious burns.
3. SPARK PLUG: Clean and reset gap to .030" every 100 hours of operation.
4. FUEL: Every 250 hours replace the in-line fuel filter or clean the screen and bowl.
5. REMOVE DUST AND DEBRIS DEPOSITS from cylinder head and cylinder head shield every 100 to 300 hours of operation.
6. CHECK GUARDS: Operate the power supply only with the guards and shields in place and working correctly. If rotating parts are left exposed they are hazardous.
7. MUFFLER: Inspect periodically and replace if necessary. Do not operate the power supply without a muffler. Inspect spark arrestor screen every 50 hours and replace if damaged.
8. INSPECT GENERATOR BRUSHES after every 100 hours of operation and replace when worn to 3/8 inch (1cm) or less. To inspect brushes, remove brush holder caps, lift brushes out gently and inspect for wear or breaks in the brush shunts. Replace brushes in the same position. Always replace brushes in sets.
9. CLEAN COLLECTOR RINGS at the same time the brushes are inspected, or after unit has been out of service for a period of time. Consult your generator's OEM manual for proper cleaning procedures.

BASIC TROUBLESHOOTING

PROBLEM

Generator does not generate electricity

SOLUTIONS

1. Check output voltage of generator at 12 VAC terminals with lamp or meter.
2. Be sure the load is not too large; reduce if necessary.
3. Check for short circuit in line using an ohmmeter.
4. Test diodes with ohmmeter to see if they are shorted or open.
5. Check stator winding or field winding for shorts.
6. Flash generator.

Generator voltage too high*

1. Refer to engine manufacturer's manual,
2. Check engine speed with tachometer.

Generator Voltage too low*

1. Refer to engine manufacturer's manual,
2. Check engine speed with tachometer.
3. Be sure the load is not too large; reduce if necessary.
4. Check for short circuit in line using an ohmmeter.
5. Test diodes with ohmmeter to see if they are shorted or open.
6. Check stator winding and field winding for shorts, between windings or to the generator frame.

Generator overheats

1. Check output voltage of generator.
2. Be sure the load is not too large; reduce if necessary.
3. Check for short circuit in line using an ohmmeter.
4. Be sure generator is located properly.

Generator brushes sparking

Check stator winding or field winding for shorts.

*Check after generator is sufficiently warmed up: 15 to 20 minutes.



WARNING: Always remove the engine ignition cable before checking or repairing the power supply to prevent it from accidentally starting.

SPECIFICATIONS

MODEL	2.5 - GPP	5.0 - GPP	7.5 GPP	9.0 - GPP
Conductivity (microSiemens/cm)	10-1,750	10-5,500	10-11,000	100-25,000
Rated Output Power (Watts)	2,500W	5,000W	7,500W	9,000W
Max. Current	8 amp	16 amp	62 amp	150 amp
12 volt AC/Aux.	500 W / 42 amp	2 @ 500 W / 42 amp	2 @ 500 W / 42 amp	2 @ 500 W / 42 amp
Output Pulse Modes	Pulsed AC & DC	Pulsed AC & DC	Pulsed AC & DC	Pulsed DC
DC Output Peak volt	0-500 V Low 0 - 1000 V High	0-500 V Low 0 - 1000 V High	0V - 170V, 340V, 500V, 1000V	0V - 85V, 170V, 340V, 680V
AC Output RMS volt	0-350V Low 0-700V High	0-350V Low 0-700V High	0-700 V	N/A
Output Pulse Frequency	7.5, 15, 30, 60 & 120 Hz	7.5, 15, 30, 60 & 120 Hz	7.5, 15, 30, 60 & 120 Hz	7.5, 15, 30, 60 & 120 Hz
Output Current Metering	AC & DC 0-8 amp	AC & DC 0-25 amp	AC & DC 0-199 amp	DC 0-199 amp
High voltage Output Indicator	Panel Lamp & Audio Tone	Panel Lamp & Audio Tone	Panel Lamp & Audio Tone	Panel Lamp & Audio Tone
Output and Safety Control	Foot Switch & Panel Switch	Foot Switch & Panel Switch	Foot Switch & Panel Switch	Foot Switch & Panel Switch
Seconds Timer LCD Display	0-999999	0-999999	0-999999	0-999999
Cooling Method	Fan Cooled	Fan Cooled	Fan Cooled	Fan Cooled
Output Connectors	CPC with 15' Cable	CPC with 15' Cable	CPC with 15' Cable	POS. CAM CONN. 15' Cable
Engine Size	5 hp	14 hp	14 hp	16 hp
Generator Weight	101 lbs.	255 lbs.	265 lbs.	265 lbs.
Pulsator Weight	20 lbs.	20 lbs.	30 lbs.	35 lbs.
Generator Dimensions	25.5" L x 17.5" W x 18" H	31.5" L x 21.5" W x 20" H	31.5" L x 21.5" W x 20" H	31.5" L x 21.5" W x 20" H
Pulsator Dimensions	17.5" x 17.5" x 13"	17.5" x 17.5" x 13"	20" x 15" x 16"	20" x 15" x 16"

Specification subject to change without notice.

* Note: 12 volts auxiliary power subtracts from Electrofisher power available.

GPP ELECTROFISHER USER'S MANUAL

PARTS LIST

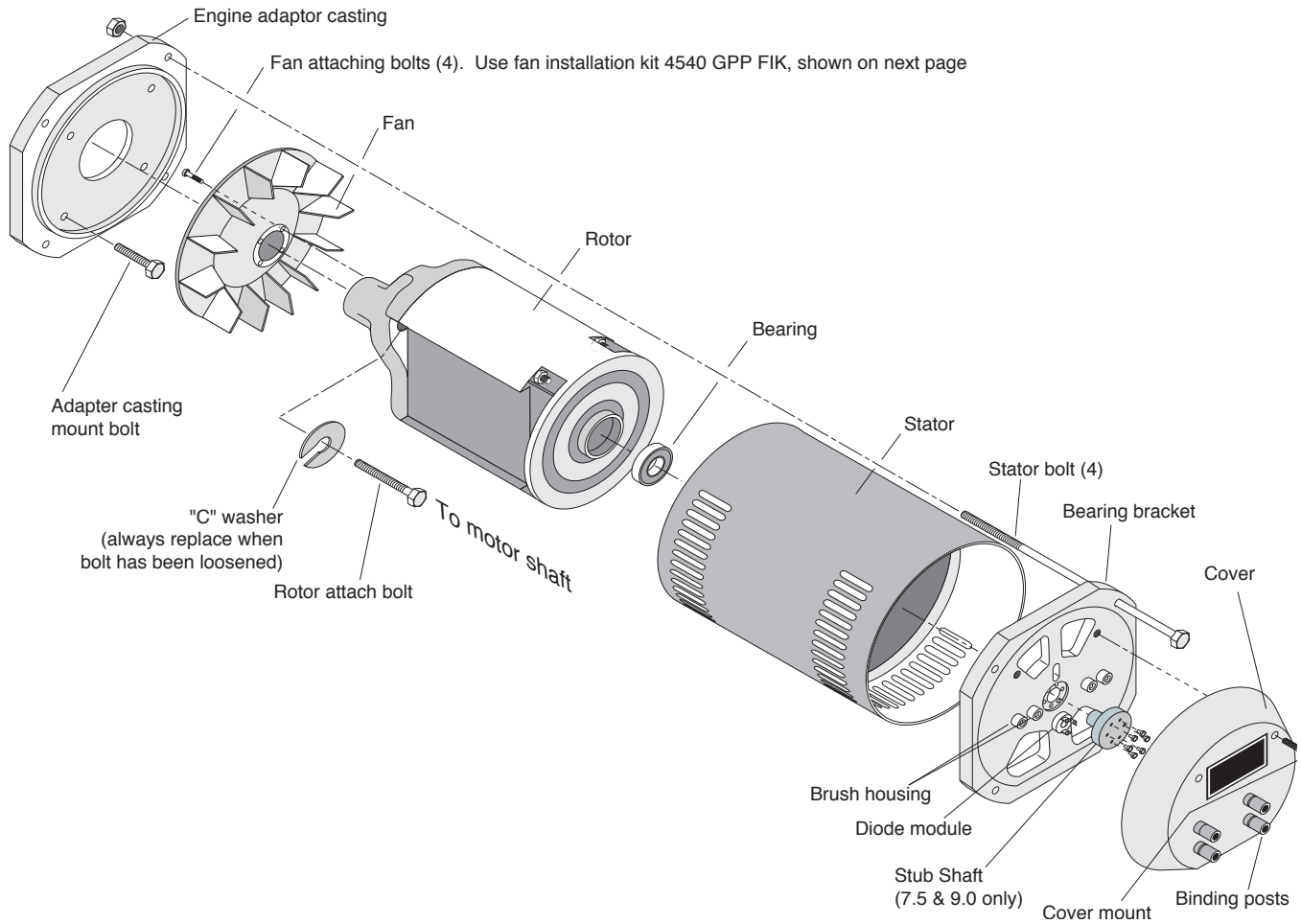

LINE #	DESCRIPTION	MODEL
04489	Stator	2.5
04649	Stator	5.0
04491	Stator	7.5
06231	Stator	9.0
04652	Rotor	2.5
04081	Rotor	5.0
02261	Rotor	7.5/9.0
02188	Brush Holder	ALL
02227	Brush Holder Cap	ALL
02267	Brush & Spring Asmb.	ALL
02954	Diode Module	ALL
04476	Fan Attach Bolt	ALL

LINE #	DESCRIPTION	MODEL
05594	Rotor Attachment Bolt	2.5/5.0
05312	Rotor Attachment Bolt	7.5/9.0
02260	Fan	ALL
08983	Cover	ALL
07393	Bearing Bracket	ALL
06279	Bearing	ALL
00000	Stator Bolt	2.5
00000	Stator Bolt	5.0
00000	Stator Bolt	7.5/9.0
04288	'C' Washer	ALL
00000	Engine Adapter	ALL

FAN INSTALLATION KIT/ ENGINE ANTI-VIBRATION MOUNTING

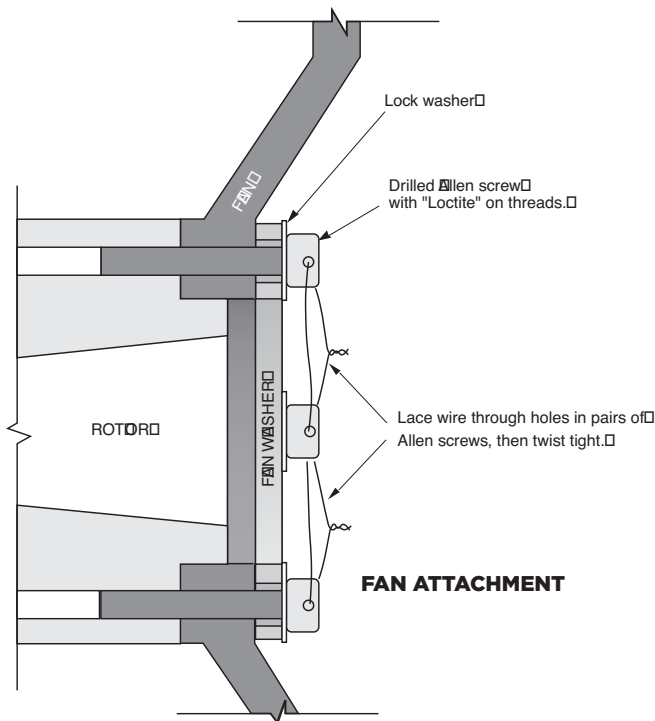

Fan Installation Kit

This fan locking assembly is recommended for Smith-Root generators.

Line#	Description
04540	Fan Installation Kit
02226	Replacement Fan

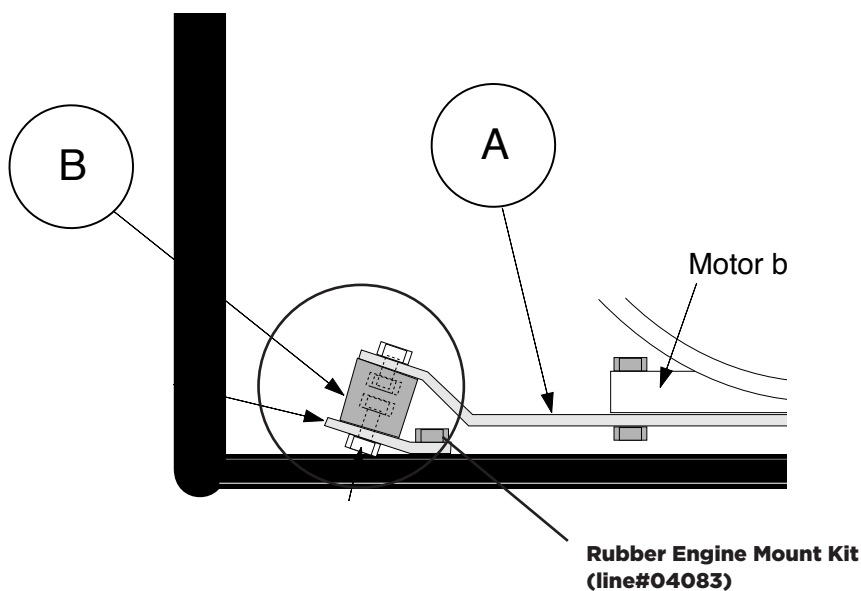

Engine anti-vibration mounting, all models

Item	GPP Model	Line#
A	2.5	06251
B	5.0, 7.5 & 9.0	06252

GPP ELECTROFISHER USER'S MANUAL

GENERATOR ANTI-VIBRATION MOUNTING

All Models

Line #04084

Item	Description	Model
A	Mounting bracket	ALL
B	Rubber mount	ALL
C	Bolt	ALL
D	Nut	ALL

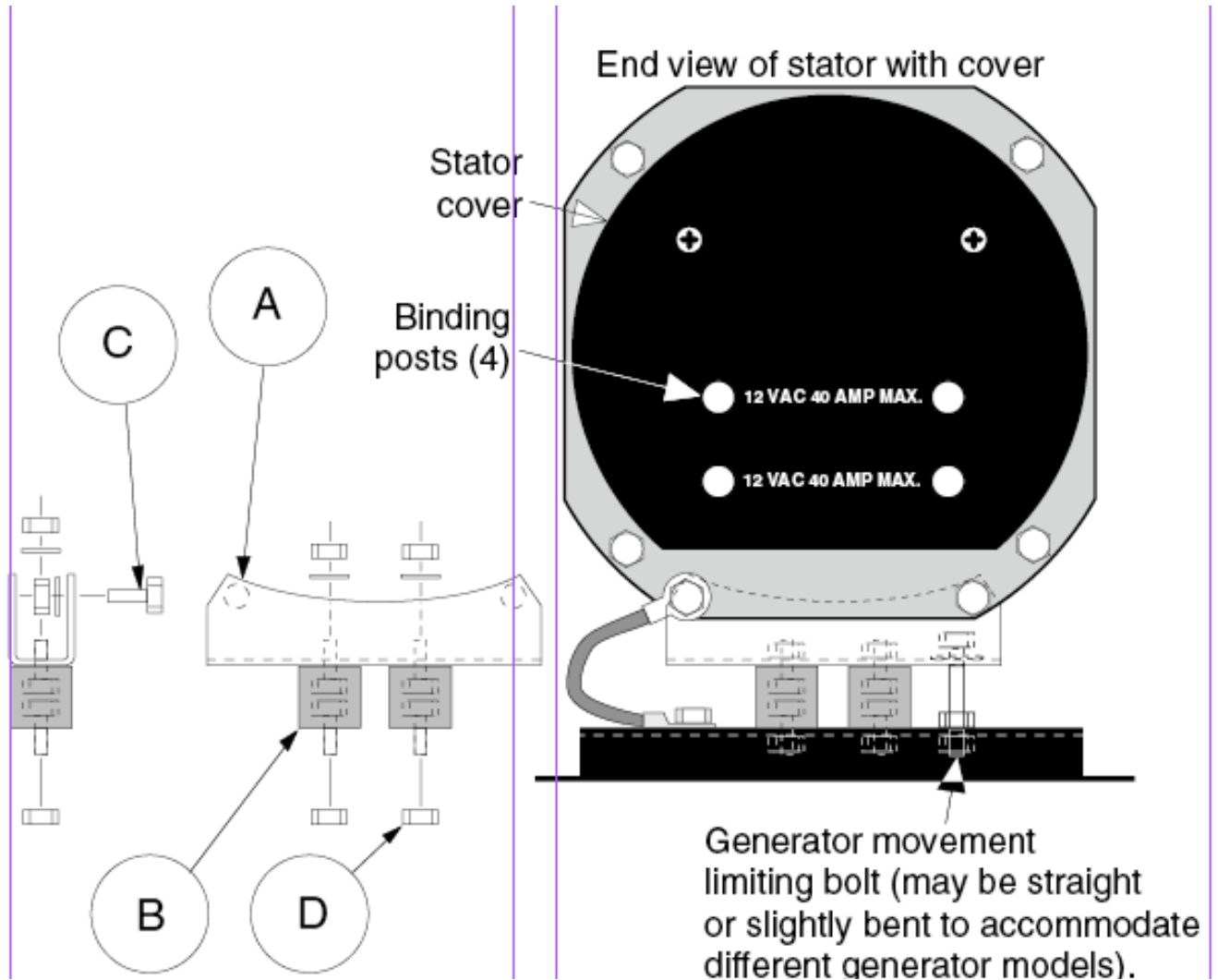

ELECTROFISHING SAFETY & PRINCIPLES

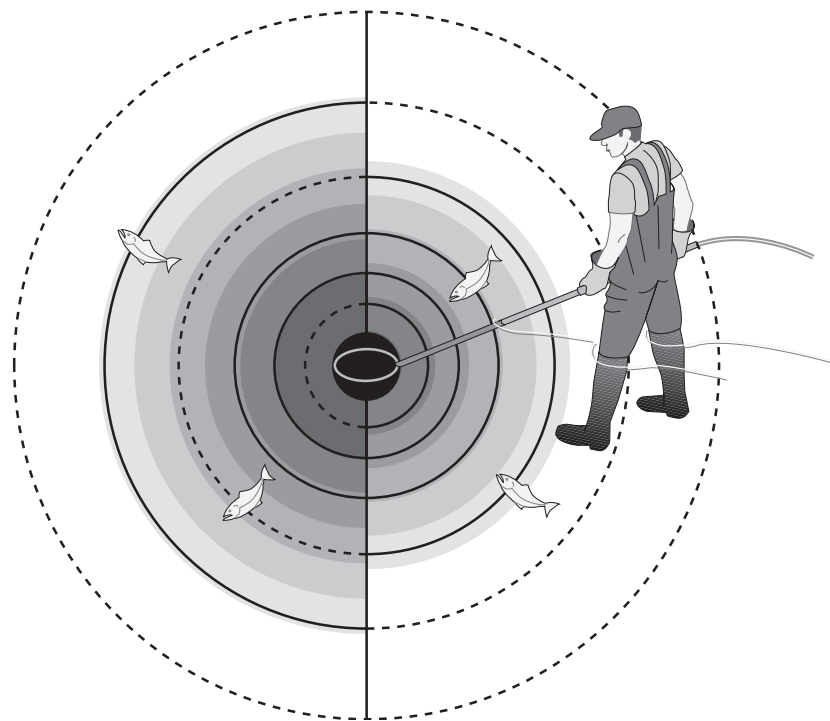

Since 1964, the leader in effective, safe, and reliable products for fisheries conservation.

Knowledgeable field biologists depend upon Smith-Root equipment.

GPP ELECTROFISHER USER'S MANUAL

CONTENTS: ELECTROFISHING SAFETY & PRINCIPLES

SAFETY

Electrofishing Safety.....	17
Backpack Safety.....	18
Boat Safety.....	18
Do's & Don'ts	18

ELECTROFISHING PRINCIPLES

Introduction to Electrofishing.....	19
Types of Current.....	21
Electrode Design.....	22
Field Techniques.....	25
References	26



ELECTROFISHING SAFETY

SAFE FISHING

Electrofishing equipment uses voltages and currents that can be lethal to humans. The operators must always keep in mind that the chance of receiving an electrical shock is multiplied in or near water. Using an electrofisher is like using a firearm: if used properly and with good judgment it is perfectly safe; lose respect for it and you can lose your life!

Electrical equipment used in a moist field environment is always subject to deterioration that could lead to dangerous electrical shock. Field equipment is also subjected to vibration and impact during transporting and while in operation. Often equipment shared by different crews does not receive proper maintenance or a complete checkout.

Follow the safety guidelines, and use good common sense to handle unforeseen circumstances.

All personnel involved in electrofishing should be taught the fundamentals of electricity, and have an understanding of the safety requirements.

The most important factor in electrofishing efficiency and safety is the training and experience of the crew. At least two members of the crew should be qualified to administer cardiopulmonary resuscitation. As opportunities arise, all crew members should attend a course in basic life-support training.

ELECTRICAL SHOCK

It is the current that passes through the human body that does the damage. The voltage is relevant, because it is the force that “pushes” the current through the body. Experiments show that 20 to 500 Hz AC current is more dangerous than DC, or higher frequencies of AC.

The voltages used by electrofishing gear cause death by one of three means:

VENTRICULAR FIBRILLATION

Ventricular fibrillation is uncoordinated contraction of the muscles of the heart. The heart quivers rather than beats. Electrical current through the

chest can cause this condition. Once a person goes into ventricular fibrillation, the only way to stop the quivering is to use a defibrillator that applies a pulse shock to the chest to restore heart rhythm. Cardiopulmonary resuscitation may help to keep a victim alive until he can be defibrillated.

RESPIRATORY ARREST

The respiratory center is at the base of the skull. Thus, shocks to the head can cause the breathing to stop. Artificial respiration by the mouth-to-mouth method should be used in this case.

ASPHYXIA

Asphyxia is caused by contraction of the chest muscles.

GPP ELECTROFISHER USER'S MANUAL

PLANNING FOR SAFETY



BACKPACK SAFETY

1. Before each operation, check that the frame emergency release is in working order and check that the tilt switch shuts off power if the unit is tipped more than 45°
2. Wear hip boots or chest-high waders, with non-skid soles.
3. Wear polarized sunglasses to help you detect sub-surface hazards and obstacles. Beware of turbid water that can hide unseen sub-surface obstacles and sudden drop-offs.
4. Shut off your electrofisher before entering or leaving a stream.
5. Do not operate an anode pole when carrying a backpack unit weighing more than 20 pounds when in hazardous conditions.
6. If you get water in boots,

waders, or gloves, stop work immediately and get dry clothing

7. Operate slowly and carefully. Footing in most streams is poor, and most falls often occur when operators are hurrying.

BOAT SAFETY

1. Ground the generator to the boat hull.
2. Be sure that all the metal parts on the boat are bonded to each other electrically.
3. Run all cables through electrical conduit, or use a heavy-duty rubber-covered cord recommended for wet locations.
4. Make all electrical connections in water-tight junction boxes.
5. Each dip netter should have his own foot switch to control the output. The switch should be wired in series with the

emergency off switch of the boat operator.

6. When wading with a boat, even in shallow water, chest waders should be worn. An operator may trip, end up in a kneeling or sitting position in the water and receive a shock.
7. All crew members must be alert. Operators who control the power switch must be constantly aware of the netters in the electrical field.

DO'S & DON'TS

DO'S:

1. Always be sure that all personnel are clear of the electrodes before turning on the power.
2. Know how to administer first aid treatment for electrical shock.
3. Wear flotation devices.
4. Have electrical circuits checked only by qualified technicians.
5. Disconnect the power supply when the electrofisher is not in use.

DON'TS:

1. Don't electrofish alone!
2. Don't continue to electrofish if your boots or gloves get wet inside.
3. Don't operate an electrofisher if you have had any prior heart ailments.
4. Don't operate generators without covers or screens.
5. Don't operate generators without a spark arrester.

INTRODUCTION TO ELECTROFISHING

For many years it has been known that fish react to electric current passed through water. Electricity was first used for fishing in 1863 when a British patent was granted. Major efforts to apply electricity as a tool in fisheries management did not occur until after 1950. Since then detailed studies have been made on the physiological effects of electricity on aquatic organisms.

RESPONSE OF FISH TO ELECTRICITY

To collect fish by electrical means we must create an electrified zone of sufficient amplitude to stun fish. In the basic electrofishing circuit, shown in Figure 1, a current is passed between submerged electrodes. A fish between these electrodes forms part of a closed circuit and some current flows through its body.

The effectiveness of the electrofisher is affected by nine factors: voltage, electrode shape, water conductivity, water temperature, conductivity of the stream bed, fish's distance, size, species, and time in the field.

If these environmental factors are too far out of line, poor electrofishing will result. To some extent, the effects of changes in water conductivity may be compensated for by changing the output voltage.

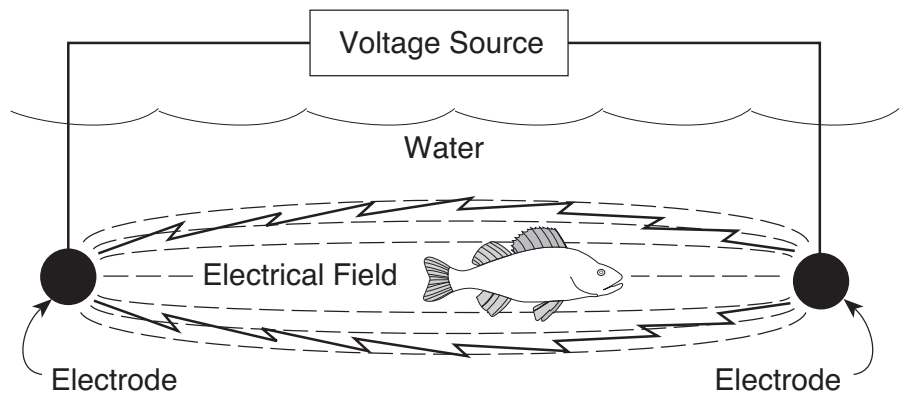

Figure 1. The basic electrofishing circuit.

WATER CONDUCTIVITY

The conductivity of the water and that of the fish's flesh are the factors that affect electrofishing most.

The conductivity of water depends on the quantity of dissolved salts and minerals in the water. The conductivity of potable waters in the United States ranges from 20 to 2,000 microSiemens/cm. Sufficient current at realistic power levels will flow through water in this range to electrofish successfully.

Figure 2 illustrates the field patterns caused by the presence of a fish in water. In (a) no distortion is caused by the presence of the fish. In low

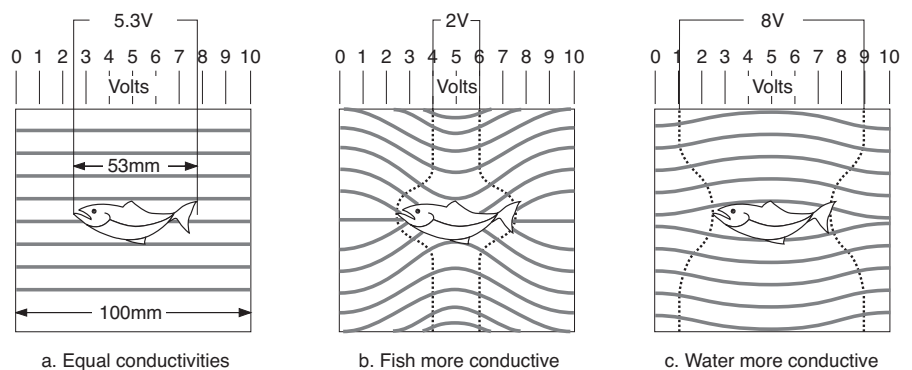

Figure 2. Electric field patterns caused by fish.

conductivity water, (b), the distortion of the electric field is such that the voltage near the fish is less than it was before the fish was present. The reverse is true in (c) where the water conductivity is more than that of the fish. In this case the distortion is caused by the current concentrating in

the water surrounding the fish. In both (b) and (c) not as much power is transferred into the fish's body as in (a).

GPP ELECTROFISHER USER'S MANUAL

LOW CONDUCTIVITY WATER

Distilled water is a very good insulator. It has a conductivity range of 0.5 to 5.0 microSiemens/cm. If a normal voltage is applied in distilled water, very little current will flow. Power flow is too low to be effective for electrofishing.

The current passing through a fish decreases as the power flow decreases. To get the same response from fish, the current can be maintained by either increasing the voltage, or by keeping the resistance low.

If a higher voltage is used, up to 1,200 volts may be necessary. High voltages create three problems, special electrical equipment is required, safety is reduced for the operators, and conditions are lethal for fish close to electrodes.

The resistance can be kept low by increasing the size of the electrodes. The only limitations to this are the availability of larger electrodes, and the weight of electrode that can be handled by the operator.

HIGH CONDUCTIVITY WATER

High conductivity is over 2,000 microSiemens/cm. If a high voltage is applied, most current will flow easily through the water and the fish will hardly be affected. The electric current follows the path of least resistance and bypasses the fish completely. Therefore use low voltages and high currents. Currents as high as 60 amps are common, the

limiting factor being the rating of the power-supply.

Some brackish water and industrial waste water have conductivities over 10,000 microSiemens/cm. Here smaller power-supplies are unable to deliver enough power to stun fish. Waters in this range can only be electrofished effectively with the larger model GPPs.

The Smith-Root 7.5 GPP outputs 62 amps through 8 gauge stranded cables. This unit can stun large fish in the interface between fresh and salt water. For example, Striped Bass can be stunned for taking brood stock.

Theoretically high conductivity could be dealt with by using smaller electrodes, but this would reduce the range and also create damaging current densities near the anode.

FISH CONDUCTIVITY

A fish will receive the maximum shock through its body when the conductivity of the water is the same as the conductivity of the fish's flesh. Unfortunately, this is rarely the case. Generally, fish conductivity is around 115 microsiemens/cm.

FISH SIZE

Among fish of the same species, the larger fish are more sensitive to electrical currents. Fish absorb power as a function of body surface area. This is important to

remember if you are shocking for small fish and large fish are also present. The large fish are going to receive a much greater shock than the small fish.

TEMPERATURE

Water conductivity increases with temperature.

SUBSTRATE

Certain bottom substrates will conduct electrical current. These weaken the electric field in the water, making fish capture less effective.

ADJUSTING THE VOLTAGE

By adjusting the output voltage, the effects of the water's conductivity on electrofishing can be reduced.

The current flowing through the water is directly related to the voltage applied. The higher the voltage, the greater the current will be.

When adjusting the output voltage the major consideration is the power being used. This is especially true for battery powered electrofishers. Power is equal to the voltage multiplied by the current. When figuring the power for an electrofisher, the fact that it is usually putting out pulsed DC must be taken into consideration. The instantaneous power during a pulse may be quite high, but if the electrofisher is only producing pulses at a 25% duty cycle, the average power would be approximately 25% of the instantaneous power.

TYPES OF CURRENT

ALTERNATING CURRENT

Alternating Current (AC) is an electrical current in which the direction of current flow reverses a number of times per second.

In an AC field, the fish takes a position transverse to the electrical field lines and attempts to face the anode and cathode successively, in rhythm with the AC cycle. When the field strength increases, tetany occurs, and the fish is stunned. Strong contractions of the body muscles make the fish feel rigid.

At high voltages, the larger fish may be killed, the muscular contractions being so severe that vertebrae are fractured and the brain damaged. Hence AC electrofishing is only successful with small fish in low conductivity water.

DIRECT CURRENT

Direct Current (DC) is the term given to electrical current that flows only in one direction. The current flows from the negative electrode (cathode) to the positive electrode (anode).

The reaction of fish to direct current is quite different from their reaction to alternating current. The first reaction of the fish is to turn toward the anode and start to swim toward it until it reaches an electrical field strong enough to stun it. Being stunned is called galvanonarcosis. The severe muscle contractions caused by AC do not occur, and

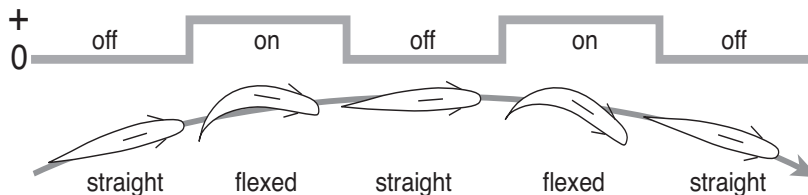

Galvanotaxis: In pulsed DC a fish's body flexes with each pulse.

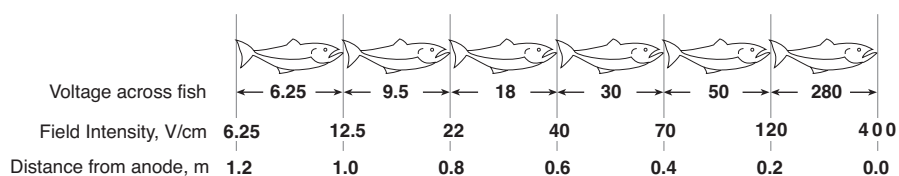

As the fish nears the anode it receives a very high head-to-tail voltage.

the fish recover much faster. Mortality rate is much lower with direct current.

PULSED DIRECT CURRENT

Even greater anode attraction is possible with pulsed direct current. Pulsed direct current is made by interrupting steady DC with an electronically controlled switch. The switch gives several on-off pulses per second. The number of pulses per second (pulse frequency) and the on time (pulse width) have different effects on different species of fish.

In a pulsed DC field a fish's body flexes with each pulse, and returns to normal between pulses. This flexing and straightening accentuates the involuntary swimming towards the anode, called galvanotaxis.

Smith-Root Programmable Output Waveforms give you complete control over your electrofisher output. This patented method of synthesizing waveforms makes it possible to produce virtually any waveform, so you can select the one that is safest for the fish. POW allows you to create narrow pulses to achieve the same results as wide pulses. Narrower pulses put less power into the water. This has three benefits: you have less chance of damage to the fish, your battery or fuel lasts longer, and you can work in very conductive water that overloads conventional electrofishers.

GPP ELECTROFISHER USER'S MANUAL

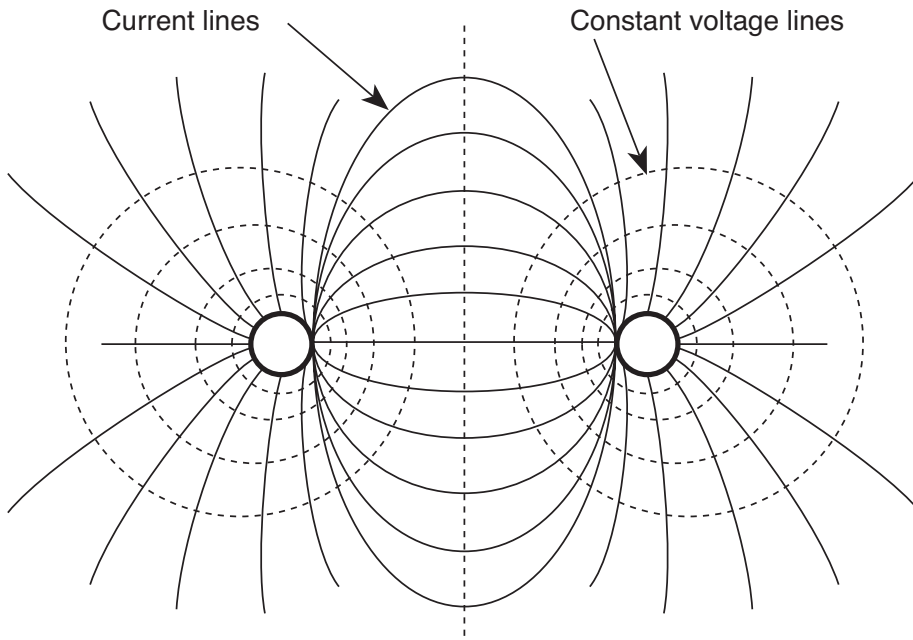

The field pattern.

RESPONSE OF FISH TO DC FIELDS

An electric field in water can be considered to have three separate areas. The outer peripheral area is a weak field that the fish is indifferent to. The next area, closer to the electrodes, has a stronger electrical field, but not enough to stun the fish. In this area, the involuntary swimming action will occur and the fish will swim towards the anode. The innermost area has the strongest electrical field, and the fish within it are immobilized.

ZONE OF POTENTIAL FISH INJURY

Fish close to the anode receive a very high head-to-tail voltage. Most fish injuries occur within half a meter from the anode. This is called the Zone of potential fish injury. We can minimize the injury by reducing the time the electricity is turned on .

DUTY-CYCLE

Duty-cycle is the percent of on-time. It is a product of the pulse width and the pulse frequency. The duty-cycle can be lowered in three ways: by reducing the pulse width, by reducing the pulse frequency, or by using gated bursts, where the power is off for a period between each burst of pulses. Fish close to an anode with a low duty-cycle are far less likely to be injured than with a high duty-cycle.

ELECTRODE DESIGN

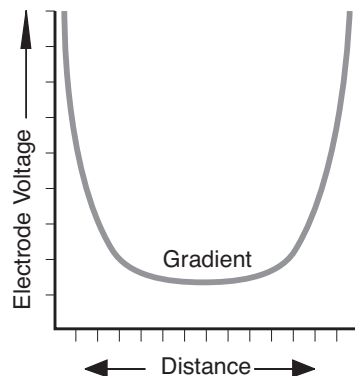

Figure 4. The variation between two electrodes.

The way in which voltage and current distribute around electrofisher electrodes is complex. Figure 4 shows the field pattern created by a pair of closely spaced ring electrodes, and the voltage gradient between them. Note that the current density and voltage gradient are highest near the electrodes.

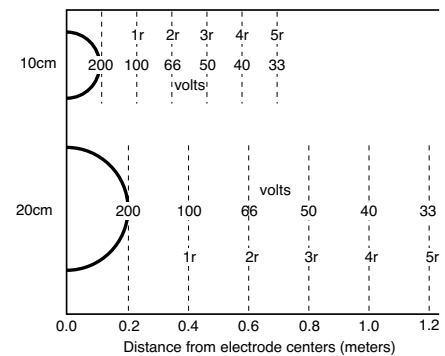

Figure 5. Comparison of two sizes of anode.

The dimensions of the electrodes are very important in determining the voltage distribution around electrofisher electrodes. Figure 5 compares a 10cm and a 20cm ring anode carrying 200 volts in open water. The cathode dimension is considered to be infinite. Note that the 20cm anode reaches out much further, producing a 33 volt potential at 1.2 meter. But the 10cm anode produces the same potential at only 0.6 meter from the electrode.

Figure 6 further illustrates the effect of electrode diameter. The voltage is applied head-to-tail to a 20cm long fish. The applied voltage is 200 volts with 10cm and 20cm diameter ring-electrodes. Note that the 20cm electrode reaches out farther, producing 7 volts head-to-tail between 1.0 and 1.2 meter

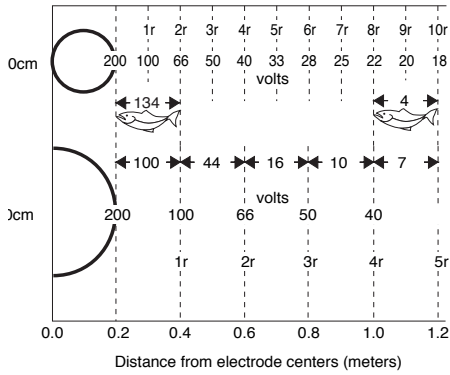

Figure 6. Comparison of effects of two sizes of anode.

from the electrode; as opposed to only 4 volts for the smaller electrode at the same distance. Note also that the voltage the fish receives closer to the electrode is less for the larger electrode (100 volts instead of 144 volts). Larger electrodes thus offers two advantages: greater range, and lower maximum gradient.

One drawback is that a larger electrode also has greater circuit loading, and thus draws more current for the same voltage (twice as much for the double size electrode). Thus, a larger electrode requires a larger generator. This dictates a practical upper limit on electrode size for a given generator and water conductivity. Except for this limitation, the larger the electrode, the better the fishing

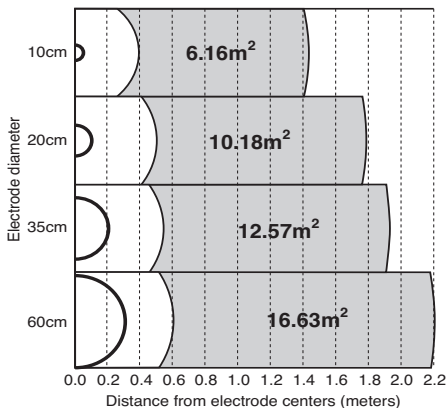

Figure 7. Larger anodes increase the fishing area.

effectiveness and the easier it is on the fish.

Figure 7 shows that larger electrodes increase the fish collection area. The shaded areas have a voltage gradient between 0.12 and 1.2 volts per cm, and are suitable for electrofishing. The applied voltage is 300 volts.

ELECTRODE BEHAVIOR

- Larger electrodes have lower resistance, need more current at given voltage, reach out farther, and have lower maximum voltage gradient.
- Small electrodes pose a hazard to fish because of high current density and voltage gradient.
- Electrodes placed farther apart use less current, but the savings are not large.
- The resistance of an electrode varies in direct proportion to water resistivity.

RING ELECTRODES

- Once spacing exceeds 10 radii, the distance between electrodes is insignificant.
- The region affected by the electrode is limited to 5 to 10 radii.
- Electrode resistance is primarily dependent on electrode radius, and varies in inverse proportion to radius.
- For ring electrodes, the cross section diameter of the ring material is of little importance. If the ratio of cross section diameter to ring radius is held constant, resistance varies inversely with ring radius.

CATHODES

In electrofishing it is desirable to have a high voltage gradient around the anode, and a low voltage gradient around the cathode.

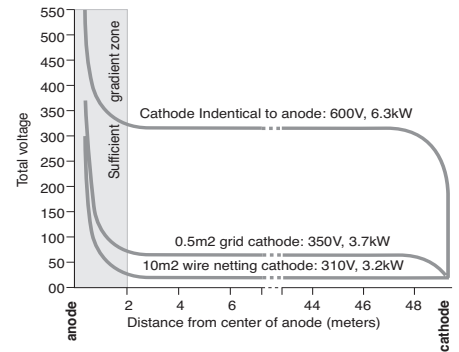

Figure 8. Variation of voltage for three different kinds of cathode

Figure 8 shows variation of voltage, as a function of the distance from the fishing anode, for three types of cathode.

The required voltage is reduced by diminishing the resistance of the cathode field. This compensates for the reduced resistance so that the current does not vary. The power consumption is directly proportional to the voltage used.

One advantage of a large cathode is that the risk of accidental electrocution is much reduced. A large cathode has very low potential with respect to the soil and the water around it. The resistance between the cathode and the water is halved each time the surface of the cathode is doubled. For example, a 100 square foot cathode would need another 100 square foot added to pass from 9 to 4.5 ohm. However a cathode larger than 100 square feet would be inconvenient to handle for shore-side electrofishing.

GPP ELECTROFISHER USER'S MANUAL

	Standard 0.5m ² grid cathode		Large wire-netting cathode	
	a. one anode	b. two anodes	c. one anode	d. two anodes
Resistance ohms				
of cathode	35	35	9	9
of anode field	90	50	90	50
between anode and cathode	125	85	99	59
Potential difference volts				
between cathode and water	126	185	32	54
between anode and water	324	265	324	302
total	450	450	326	356
Current amps	3.6	5.9	3.6	6.0
Power kilowatts	1.62	2.38	1.28	2.15

Figure 9. Comparison of two sizes of cathode.

Figure 9 compares small and a large cathodes. With a standard grid cathode, the anode voltage falls distinctly from 324 to 265 volts when using two anodes. However with a very large wire netting cathode efficiency falls only slightly from 324 to 302 volts when using two anodes.

For shore-side operations, the cathode surface presents the least resistance when it is divided into several parts placed several meters apart. An electrode is more effective when its form is least concentrated. For example, a 3'x12' strip is more effective than a square of 6'x6'.

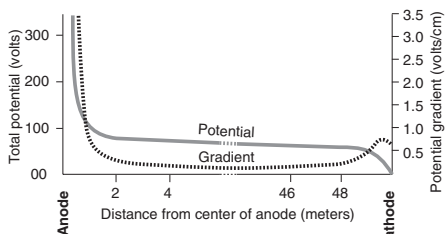

Figure 10. Variation of potential and gradient.

Figure 10 illustrates the variation in both voltage and gradient between the electrodes.

Whenever possible, the cathode should be placed in parts of the stream that you do not wish to fish, or even in parts

completely separated from the stream itself. The anode should never be allowed to come close to where the cathode is located.

BOAT CATHODES

Many aluminum electrofishing boats use the boat hull as the cathode and the boom electrodes as the anode. This is perfectly safe as long as you never come in contact with the anode and complete the electrical circuit. The National Safety Council in their data sheet #1-696-85 does not recommend using the boat hull as the cathode, but we have yet to hear of any accidents occurring because of it.

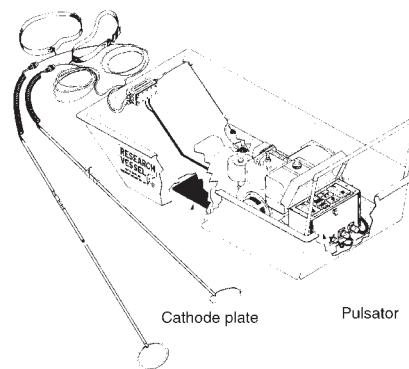
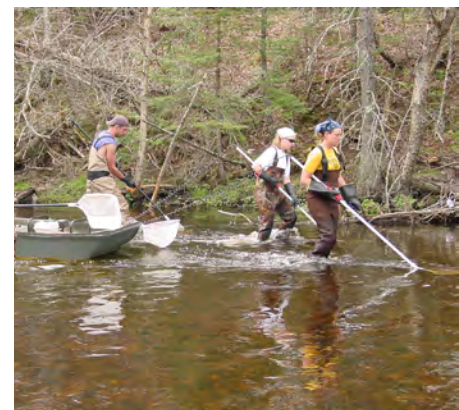

Figure 11. Bottom mounted cathode plate on SR-6.

Figure 11 shows a Smith-Root tote barge designed for stream wading operations. Note the large cathode plate attached to the bottom of the fiberglass hull. The anode is a pair of ring electrodes about 28cm (11") in diameter mounted on fiberglass poles. With this arrangement, the resistance of the anode pair is four times the cathode resistance. Thus, four times as much voltage appears in the anode field as in the cathode field, and consequently 80% of the applied voltage appears at each electrode.

The situation could be further improved by enlarging the cathode, but a point of diminishing returns is reached. Doubling the cathode size would halve the cathode resistance and give an 8 to 1 ratio between anode and cathode resistance. Now 88% of the voltage would appear at the anode. This is only an 8% improvement, and is not worth the additional physical problems associated with the larger cathode.

The SR-6 field tested with two 28cm anodes and a voltage of 240 volts, showed good fishing effectiveness in 400 microSiemens/cm conductivity with a current of 3 to 4 amperes. In lower conductivities of 40 microSiemens/cm, a current of 1 to 1.5 amp is effective. This data may serve as a useful benchmark to judge whether a unit is operating under conditions such that fish should be caught. If the electrical performance is close to this reference point, and fish are not being caught, it is safe to conclude there are few fish in the area.





FIELD TECHNIQUES

An operator engaged in electrofishing must wade or float, depending upon the depth and swiftness of the water.

WADING

In shallow slow-moving waters the operators can wade and probe the anode into likely fish habitat. Wading upstream eliminates the effects of turbidity caused by bottom sediment. Furthermore, if collections are for food habitat study, stunned prey are not swept downstream and consumed by predators. Fish that manage to escape are often captured a short distance downstream. Closing a stream with seine nets at each end of the study area helps prevent the loss of stunned and frightened fish.

BOATS

Boat electrofishers are used in lakes and in streams that are too deep or swift to wade. Boats have the advantage of being able to carry large generators and holding tanks for the stunned fish. Electrofishing boats typically have two insulated booms extending from the bow. From the end of the booms electrodes hang into the water. Usually one

boom is used as the anode and the other as the cathode. The boat operator guides the boat while the electrofishing crew activates the electrofisher when approaching likely habitat.

NIGHT FISHING

Electrofishing at night with lights is five to ten times more effective than daytime fishing, especially in lakes. In streams the reflection of the spotlight on the ruffled surface makes the fish difficult to see. Boats have flood lights on the bow to attract the fish and to help locate stunned fish.

SURPRISE

Collecting can be enhanced by introducing the element of surprise through intermittent fishing. The intensity of the anode's peripheral field often frightens fish, causing them to bolt and hide. Do not work with the power on continuously, but turn it on only in likely habitats. Fish can be enticed from under areas of heavy cover or ice by inserting a portable anode, turning the power on, and withdrawing the anode slowly and smoothly. Fish will follow the anode, under the influence of

galvanotaxis, into the open where they can be netted.

CLARITY AND DEPTH

Clarity of the water limits the ease of capturing fish. The length of the dip net handles and the visibility of the fish limit the depth of effective electrofishing. In general, waters over ten feet deep cannot be sampled effectively. For daytime fishing polarized sunglasses help in locating stunned fish.

VEGETATION

Aquatic vegetation grows better from certain substrates and can hinder electrofishing by fouling electrodes and entangling stunned fish.

WATER VELOCITY

Electrofishing in flowing water is not as effective as in still water, since fish are swept away from the electric field and netting is more difficult. Also, it is more difficult to see a fish in fast flowing water, and operators can lose their footing. Flows greater than 5 feet per second usually produce poor electrofishing efficiencies.

ELECTROFISHING REFERENCE & TRAINING MATERIALS

REFERENCES

The following are books, research papers, and other references on various aspects of electrofishing. The ideas and findings presented in them form the basis for much of the current practice in electrofishing.

1. Bryan R. Cowdell and Richard A. Valdez, 1994 "Effects of Pulsed DC Electrofishing on Adult Roundtail Chub from the Colorado River in Colorado," North American Journal of Fisheries Management. Vol. 14
2. I. G. Cowx and P. Lamarque, 1990, "Fishing With Electricity—Applications in Freshwater Fisheries Management," Fishing News Books, Blackwell Scientific Publications Ltd. ISBN 0-85238-167-0
3. L. G. Cowx, 1990 "Developments in Electrofishing," Fishing News Books, Blackwell Scientific Publications Ltd. ISBN 0-85238-166-2
4. N.G. Sharber and S.W. Carothers, 1988 "Influence of Electrofishing Pulse Shape on Spinal Injuries in Adult Rainbow Trout," North American Journal of Fisheries Management. 8: 117-122
5. Michael A. Bozek and Frank J. Rahel, 1991 "Comparison of Streamside Visual Counts to Electrofishing Estimates of Colorado River Cutthroat Trout Fry and Adults," North American Journal of Fisheries Management. Vol. 11
6. D. W. Novotny and G. R. Priegel, 1971 "A Guideline for Portable Direct Current Electrofishing Systems," Technical Bulletin No. 51, Department of Natural Resources, Madison, Wisconsin
7. D. E. Snyder and S. A. Johnson, 1991 "Indexed Bibliography of Electrofishing Literature," Larval Fish Laboratory, Colorado State University, Fort Collins, Colorado.
8. M. Burridge and G. Goodchild, 1988 "A Bibliography of Electrofishing," Ministry of Natural Resources, Fisheries Branch, Queen's Park, Toronto, Ontario, Canada.
9. Alec G. Maule and Matthew G. Mesa, 1994 "Efficacy of Electrofishing to Assess Plasma Cortisol Concentration in Juvenile Chinook Salmon passing Hydroelectric Dams on the Columbia River," North American Journal of Fisheries Management. Vol. 14
10. N.G. Sharber, S.W. Carothers, J.P. Sharber, J.C. DeVos, D.A. House, 1994 "Reducing Electrofishing-Induced Injury of Rainbow Trout," North American Journal of Fisheries Management. 14
11. Jeffery C. Barnet and Gary D. Grossman, 1988 "Effects of Direct Current Electrofishing on the Mottled Sculpin," North American Journal of Fisheries Management. Vol. 8

APPENDIX

GPP TROUBLESHOOTING

SHORE MODEL (USING KOHLER CH GENERATOR)

Contents

Check Generator 12 AC Voltages (all models).....	28
Test for Continuity, High Voltage AC Output.....	29
Check connections, brushes, exciter rectifier	30
Check Rotor Windings.....	31
Check Stator Windings.....	32
Test GPP Control Box	33
Test GPP Control Box	34
Flashing the Rotor	35
Build a Test Load.....	36
2.5 & 5.0 GPP Generator Stator Wiring	37
7.5 GPP Generator Stator Wiring	38
9.0 GPP Generator Stator Wiring	39

GPP ELECTROFISHER USER'S MANUAL

PROBLEM: NO OUTPUT FROM GPP ELECTROFISHER

PROCEDURE 1: CHECK GENERATOR 12 AC VOLTAGES (ALL MODELS)

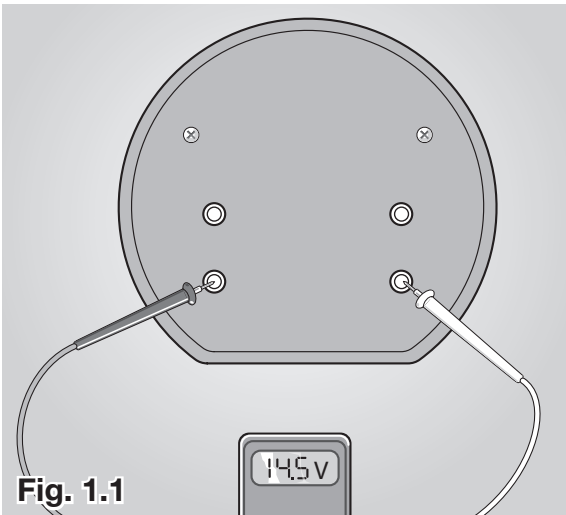

GPP Electrofishers have two 500-watt accessory 12 Volt AC windings. The accessory output terminals are located on the generator end-bell.

- Set the GPP Control Box Voltage range switch to off. Adjust generator engine speed to 3600 RPM using a vibrating tachometer which is available at most small engine shops.
- Check the 12 Volts AC on the end bell of generator using an AC Voltmeter (**See Fig. 1.1**). They should read approx. 14.5 Volts, 60Hz.

-2.5 and 5.0 GPP Only:

- Check the 12 Volts AC on the output connector. Pairs: 5 & 6 (**See Fig. 1.2**).

If the Voltages are OK, go to procedure 2.

- Flash generator (Follow procedure 8).
- Restart procedure 1.

If 12 Volts AC are still not present, go to procedure 3.

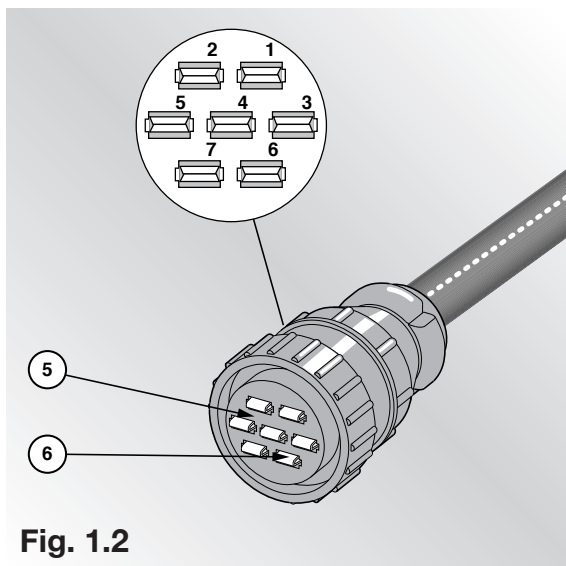

IMPORTANT!: High voltages are present when generator is running. Only qualified personnel should attempt high voltage measurements. We suggest forming a barricade around the test area and posting appropriate high voltage warning signs.

PROBLEM: NO OUTPUT FROM GPP ELECTROFISHER (CONT.)

PROCEDURE 2: TEST FOR CONTINUITY AND HIGH VOLTAGE AC OUTPUT

SHUT DOWN GENERATOR!

Check all the connector pairs resistance to Generator ground.

2.5 and 5.0 GPP:	1 & 2 / 3 & 4 (See Fig. 2.1)
7.5 GPP:	1 & 2 / 3 & 4 / 5 & 6 (See Fig. 2.2)
9.0 GPP:	1 & 2 / 3 & 4 / 5 & 6 (See Fig. 2.3)

All of the pairs should show open or high resistance (>0.5 Meg-ohm).

- Next, check insulation between winding pairs. If resistance measures low, the wire or generator insulation is bad.

If low resistance is measured, go to procedure 5.

- With generator running, check for High Voltage on generator connectors. (See wiring diagrams at the end of this document).
- 2.5 and 5.0 GPP: Check each of the High Voltage terminal pairs on the output connector for aprx. 360 Volts RMS AC. Pairs: 1 & 2 and 3 & 4 (See Fig. 2.1). 7.5 GPP: Check each of the Voltage terminal pairs on both of the output connectors for approximately 115 Volts
- RMS AC. Pairs: 1 & 2, 3 & 4 and 5 & 6 (See Fig. 2.2).
- 9.0 GPP: Check each of the Voltage terminal pairs on both of the output connectors for approximately 67 Volts RMS AC. Pairs: 1 & 2, 3 & 4 and 5 & 6 (See Fig. 2.3). Also, check for
- 115 Volts RMS AC on the smaller 2-pin connector.

If the Voltages are LOW or absent go to procedure 3.

If the Voltages are OK, go to procedure 6.

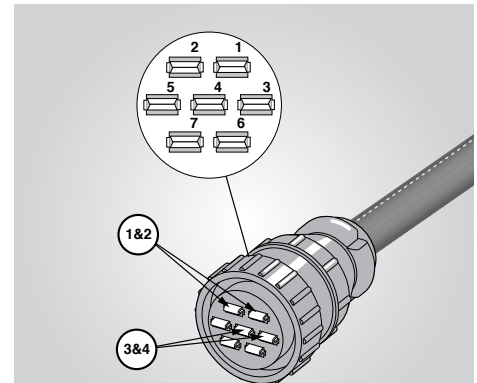

Fig. 2.1: 2.5 & 5.0 GPP

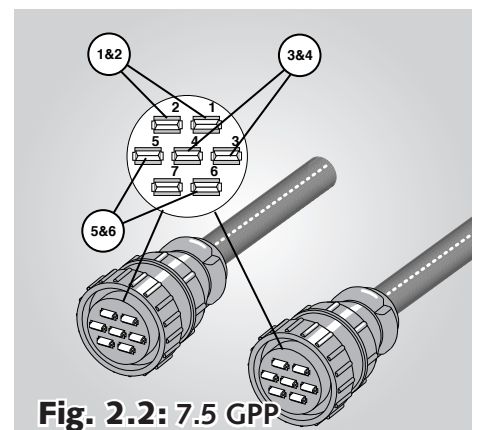

Fig. 2.2: 7.5 GPP

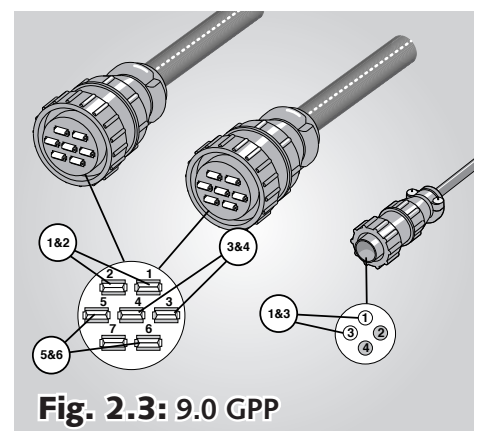

Fig. 2.3: 9.0 GPP



IMPORTANT!: High voltages are present when generator is running. Only qualified personnel should attempt high voltage measurements. We suggest forming a barricade around the test area and posting appropriate high voltage warning signs.

GPP ELECTROFISHER USER'S MANUAL

PROBLEM: NO OUTPUT FROM GPP ELECTROFISHER (CONT.)

PROCEDURE 3: CHECK CONNECTIONS, BRUSHES, AND EXCITER RECTIFIER

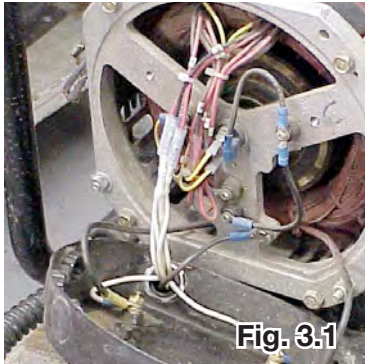

Fig. 3.1

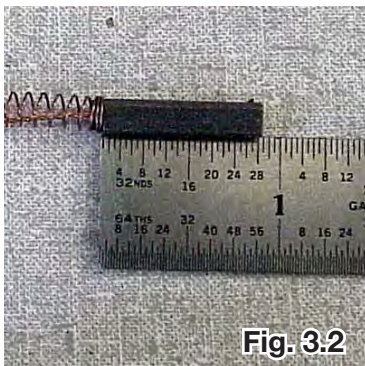

Fig. 3.2

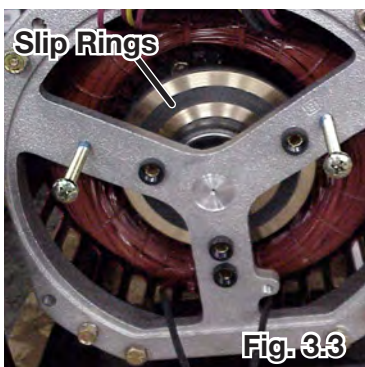

Fig. 3.3

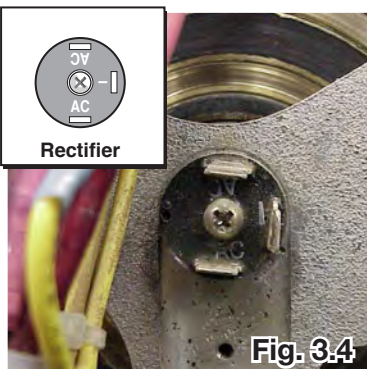

Fig. 3.4

- Turn generator off before troubleshooting.
- Open the generator end-bell cover by removing the two large screws on the housing cover.
- Inspect the wire bundles for chaffing, loose or broken connections. Repair if needed (See Fig. 3.1).
- Check brushes - replace brushes if length less than 3/8" (1 cm) (See Fig. 3.2).
- Clean rotor slip rings with fine non-metallic abrasive pad such as 3-M "Scotch Brite" (See Fig. 3.3).
- Disconnect wires from rectifier. Check 3-pin rectifier with ohmmeter in diode testing position. The rectifier should only conduct one way between AC and negative pin. Replace if shorted between pins or if open between pins. (See Fig. 3.4 and inset).
- Correct problems, reassemble and retest using procedure 1 and 2.

If there is still no voltage at connector, continue to procedure 4.

PROBLEM: NO OUTPUT FROM GPP ELECTROFISHER (CONT.)

PROCEDURE 4: CHECK ROTOR WINDINGS

Disconnect yellow wires from the brush end cap and the Rectifier. (See Fig. 4.1).

Measure resistance with ohmmeter between rotor slip rings, through the Brushes. Brushes are accessible via the brush end-caps. (See Fig. 4.2).

Resistance should read as follows:

- ffi24 ohms - 2.5 GPP
- ffi32 ohms - 5.0 GPP
- ffi36 ohms - 7.5 and 9.0 GPP

If resistance varies significantly from above, take measurements directly from the slip rings.

Check Rotor Slip Rings to ground (OPEN connection). (See Fig. 4.3). Replace rotor if measurements are out of specifications.

Go to procedure 5.

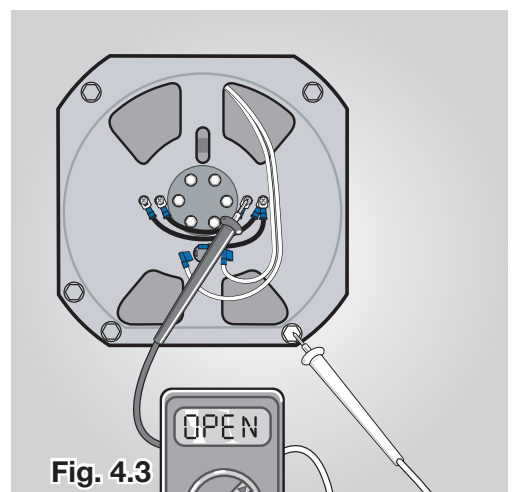
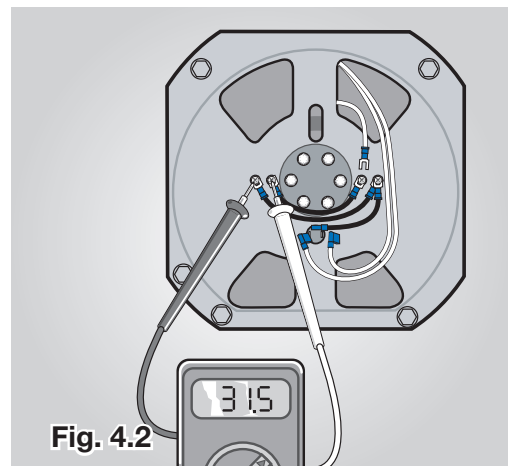
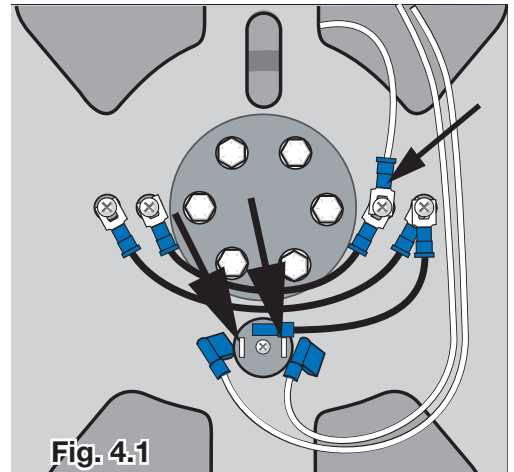

GPP ELECTROFISHER USER'S MANUAL

PROCEDURE 5: CHECK STATOR WINDINGS

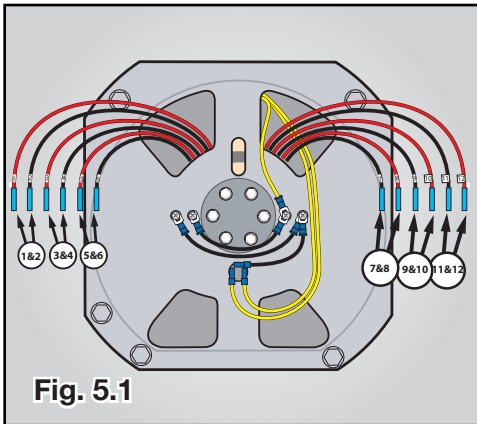

Fig. 5.1

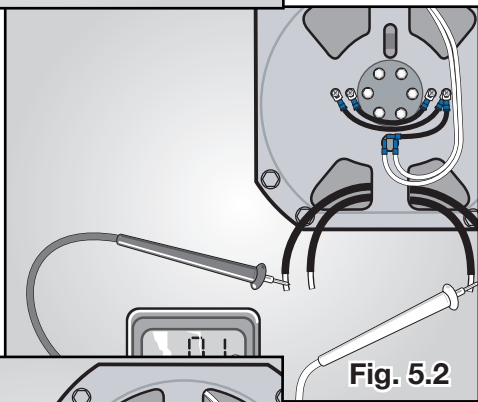

Fig. 5.2

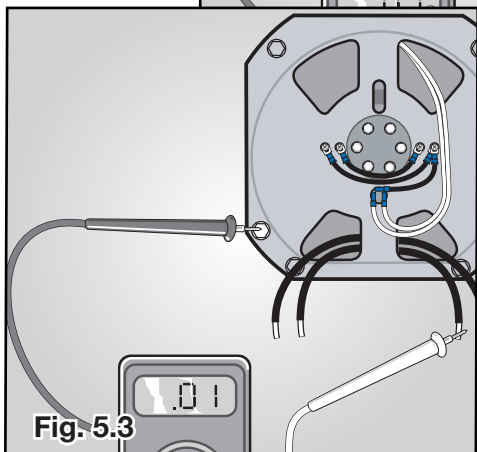

Fig. 5.3

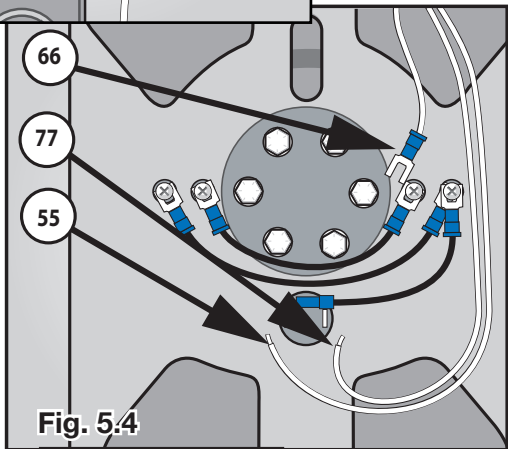

Fig. 5.4

- Check wire number tags. Label with tape and pen if missing.
- Cut wires at crimp connectors.
- Strip insulation back 1/4" (0.5 cm) to expose bare wire.
- Test winding pairs (1 & 2, 3 & 4, 5 & 6, 7 & 8, 9 & 10, 11 & 12,) (See Fig. 5.1)
- Test yellow exciter wires (See Fig. 5.3) according to table below.

	GPP Model	
	2.5	5.0, 7.5 & 9.0
Ω	≈ 1.2 Ohms	≈ 0.4 Ohms

- Test 12 Volt winding pairs (White/White, Black/Black). Each should measure ≈ 0.1 Ohms (See Fig. 5.2).

Exciter Wires	GPP Model	
	2.5	5.0, 7.5 & 9.0
66&55	$\approx 2.0\Omega$	$\approx 1.7\Omega$
77&55	$\approx 4.0\Omega$	$\approx 3.4\Omega$
66&77	$\approx 2.0\Omega$	$\approx 1.7\Omega$

- Check insulation of all windings to ground (open connection). (See Fig. 5.4.)
- Replace Stator if out of specifications.

Rotors and end bearings should be replaced as a set. Replace rotor bearing support bracket if old type. Contact Smith-Root, Inc. for further information.

PROCEDURE 6: TEST GPP CONTROL BOX

Test a single or dual foot switch pedal using an ohmmeter. Carefully connect the ohmmeter connectors to pins (A & B) on the 4-Pin male plug. Use care to not allow the ohmmeter connectors to touch when connecting them to the pins on the 4-Pin male plug. (See Fig.6.1).

The ohmmeter should measure OPEN ohms with the switch off and ZERO ohms with the switch on. If it does not you may have a broken wire or a bad switch inside the pedal. If foot switch is inoperative, return to Smith-Root, Inc. for service. Test dual foot switches with an ohmmeter using the same method as shown above. Connect the ohmmeter to pins (A & B) on the 4-Pin connector for switch #1 and to pins (C & D) for switch #2 (See Fig. 6.1).

- Connect the generator to GPP Control Box.
- Connect the foot switch to GPP Control Box.
- Connect a test load to output cables (see Procedure 9).

WARNING! Keep all personnel clear of the Test Load while the generator is running!

- Switch mode switch to 120 PPS.
- Turn Percent of Range to 50%.
- Switch the output Voltage selector to low range.
- Switch the “Emergency Shutdown Switch” to OFF position (See Fig. 6.2, A).
- Start the generator.
- Switch the “Emergency Shutdown Switch” to ON position (See Fig. 6.2, B).
- Press the foot switches.
- The red light (See Fig. 6.2, C) on the front panel should now be illuminated and the amp meter should indicate amperage.
- If the red light is not illuminated and the amp meter indicates no amperage:
 - Turn the generator off.
 - Check the light bulb.
 - Check the Fuse on the GPP main circuit board (See Fig. 6.3).
 - Replace fuse if blown. A blown fuse may indicate a short in the Audio Alarm. Disconnect the Audio Alarm (See Fig. 6.4) before retesting.

Return to start of Procedure 6. If Red light and amp meter indicates output go to Procedure 7.

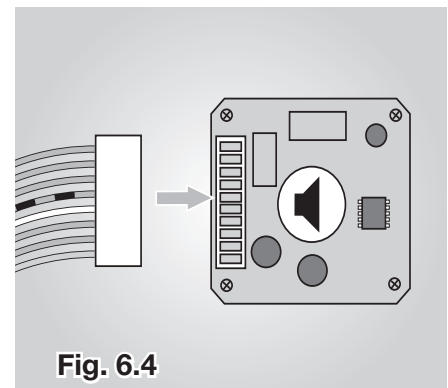
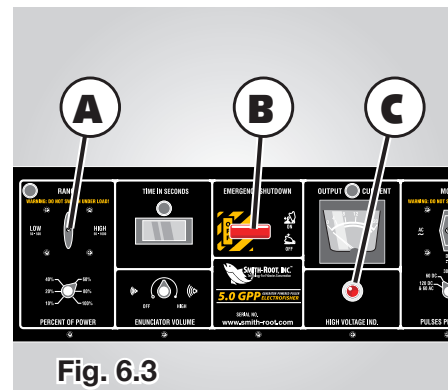
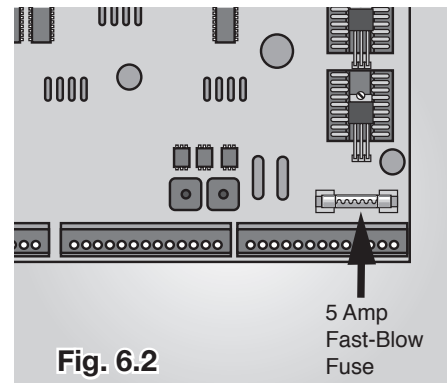
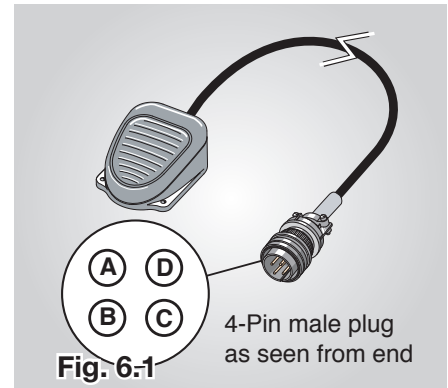

GPP ELECTROFISHER USER'S MANUAL

PROCEDURE 7: TEST GPP CONTROL BOX

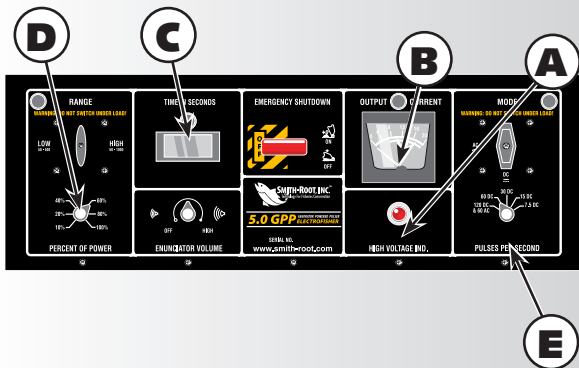

Fig. 7.1

- Maintain GPP settings from Procedure 6.
- Start the generator.
- Press foot switches.
- When the Red Light (See Fig. 7.1, A) is illuminated, the “Current Meter” (See Fig. 7.1, B) should show amperage and the “Seconds Counter” (See Fig. 7.1, C) should be counting.
- If there is no display in the seconds counter, replace the “N” cell batteries in the counter *(See Fig. 7.2).
- Adjusting the “Percent of Range” (See Fig. 7.1, D) up to 100% will increase the amperage shown on the Current Meter.
- Set the “Percent of Range” to 50%.
- Switch the “Mode” switch (See Fig. 7.1, E) from 120 PPS to 60 PPS. The amperage should drop by half.

CAUTION: Never switch the Voltage Range while the output is ON.

- Retest settings in the high range.

NOTE: If output current is absent, return the control box to Smith-Root, Inc.

* The “N” cell batteries should be replaced EVERY five years (See Fig. 7.2).

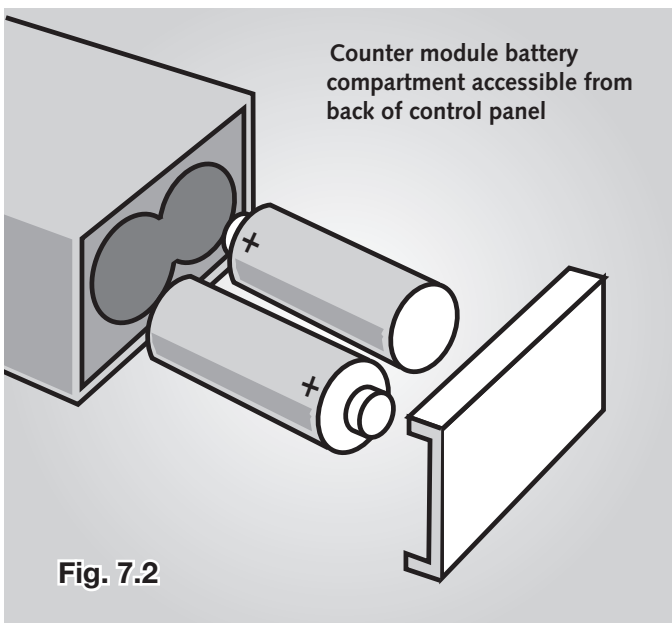

Fig. 7.2

PROCEDURE 8: FLASHING THE ROTOR

Rotor Flashing is a process of magnetizing the Rotor. This is necessary for the Generator to produce an output. This is normally done at the factory and should not be required unless the Generator has been disassembled.

Should FLASHING become necessary, stop the engine and identify the two inner and two outer brush holders. The right hand brush has a wire that connects to the three terminal rectifier assembly. The left brush is connected to the inner windings. (See Fig.8.1).

Connect the 12 Volt Battery's positive lead to the left brush terminal. Next, hold the negative lead to the right brush terminal for a minimum of ten seconds. This will re-magnetize the Rotor.

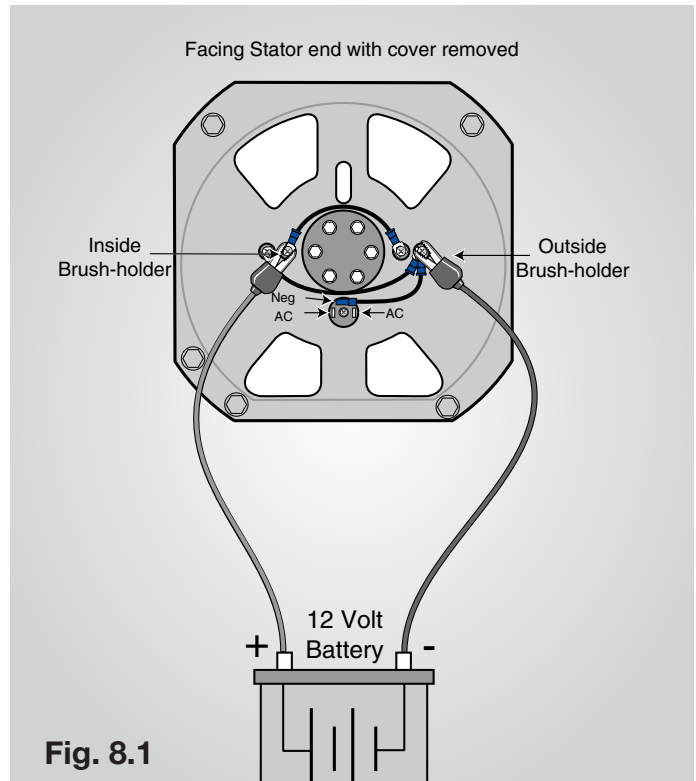

Fig. 8.1

GPP ELECTROFISHER USER'S MANUAL



IMPORTANT! Danger! High Voltage is present during test load procedure. Every effort should be made to keep all personnel away from test load bucket. It may be necessary to form a barricade around testing area and post appropriate signs warning of High Voltage.

PROCEDURE 9: BUILD A TEST LOAD

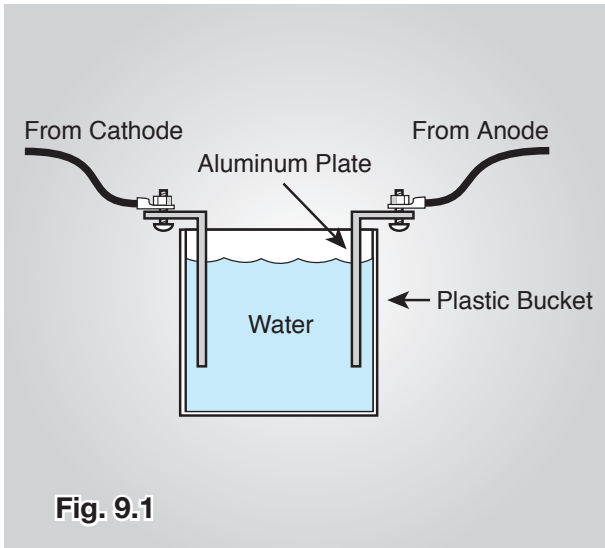

Fig. 9.1

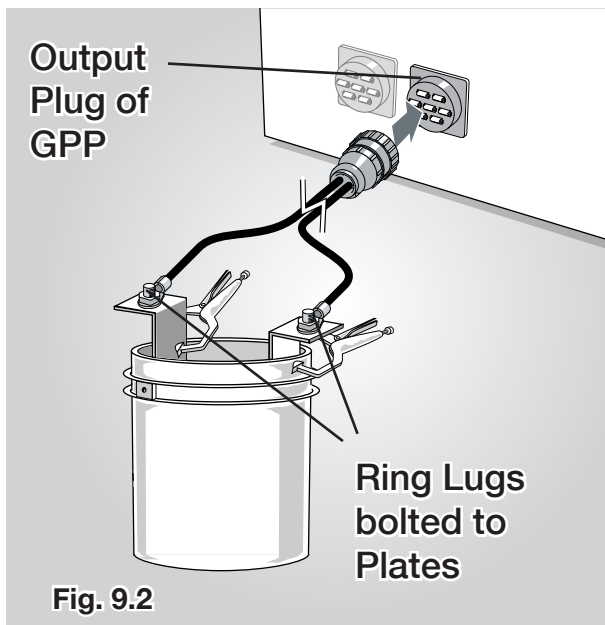

Fig. 9.2



WARNING: keep all personnel clear of test load while generator running.

- Construct a test load using a plastic bucket with the metal handle removed (Fig. 9.1).
- Connect the test load to the GPP Electrofisher as shown (Fig. 9.2).
- Add tap water to the bucket.
- Set the “Mode Switches” on the GPP Control Box to AC & 120 PPS/ 60 AC.
- Start the generator.
- Control the GPP output with the “Emergency Shut Down” switch or Foot switch.
- By turning the “Percent of Range” control up to 100% and checking the amp meter on the GPP Control Box, the correct load can be determined. See below:

Maximum GPP Amperage (2.5 - 5.0)

Model	High	Low
2.5	4 Amps	8 Amps
5.0	8 Amps	16 Amps

Maximum GPP Amperage (7.5 - 9.0)

Model	AC	DC	Amperage
7.5	120 V	170 V	62.5 A
	240 V	340 V	31.3 A
	360 V	500 V	20.8 A
9.0	720 V	1000 V	10.4 A
	60 V	85 V	150 A
	120 V	170 V	75 A
	240 V	340 V	37.5 A
	480 V	680 V	18.8 A

- The amp meter will increase to the maximum as you turn up the “Percent of Range”.
- The load may be increased by slowly adding table salt to the water in the bucket.
- If the load is too great for the range selected, the GPP will operate erratically.
- If the amp meter starts to show a decrease in amps or is erratic as the “Percent of Range” nears 100% the generator is over-loading. The water may need to be changed, or decrease the portions of electrodes immersed in the water.

2.5 & 5.0 GPP GENERATOR STATOR WIRING

All Wires to GPP Connector 14 Ga.

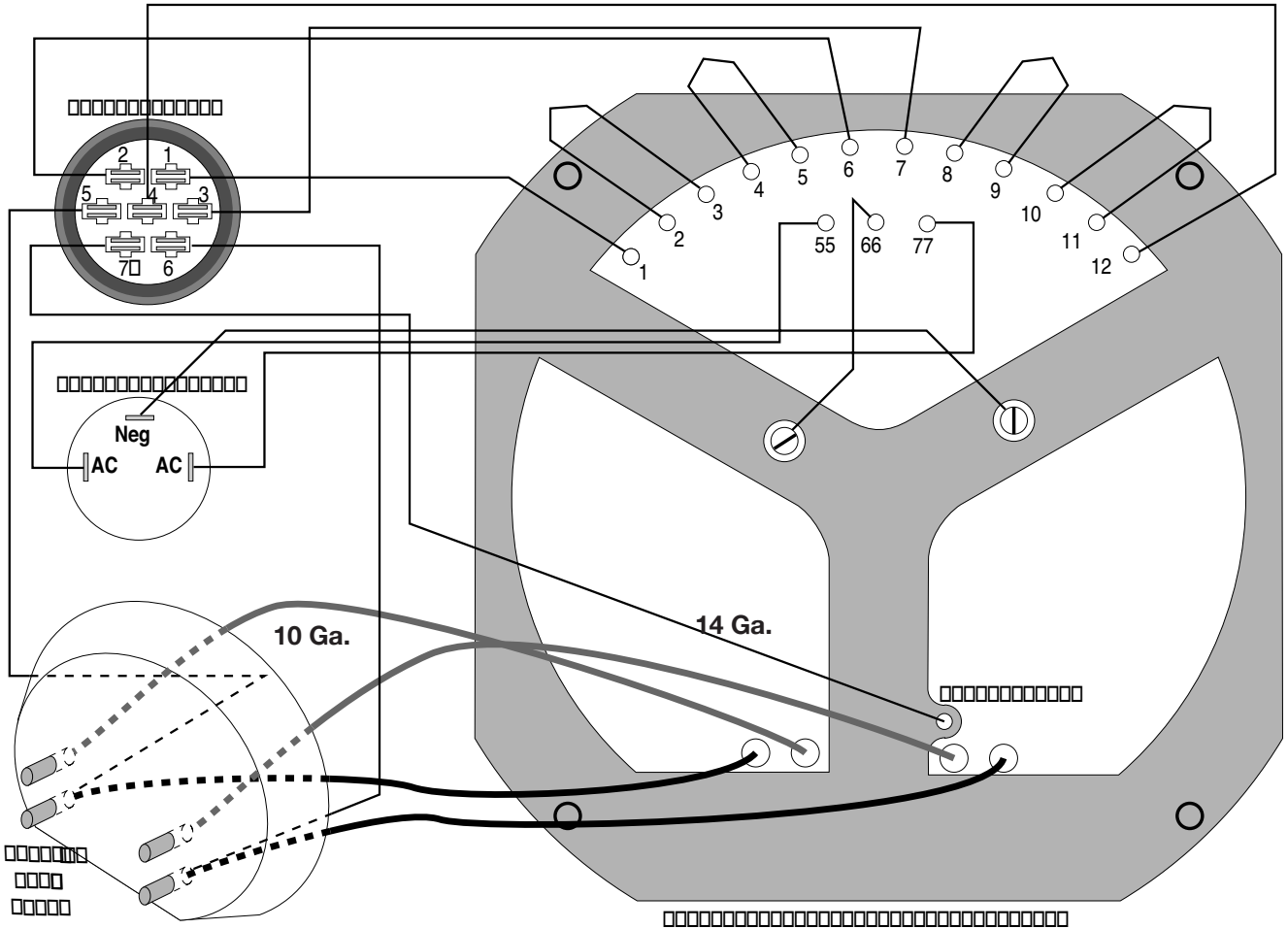

2.5 GPP

Generator Terminals
 1 - 2 = 115 Volts @ 441.5 VA
 Respectively through
 11 - 12 = 115 Volts @ 441.5 VA

(Pairings of Odd # on Left & Even # on Right.)

Output @ Binding Posts
 Black wires 12 Volts @ 500 VA
 White wires 12 Volts @ 500 VA

5.0 GPP

Generator Terminals
 1 - 2 = 115 Volts @ 883 VA
 Respectively through
 11 - 12 = 115 Volts @ 883 VA

(Pairings of Odd # on Left & Even # on Right.)

Output @ Binding Posts
 Black wires 12 Volts @ 500 VA
 White wires 12 Volts @ 500 VA

GPP ELECTROFISHER USER'S MANUAL

7.5 GPP GENERATOR STATOR WIRING

*All Wires to GPP Connectors 14 Ga.

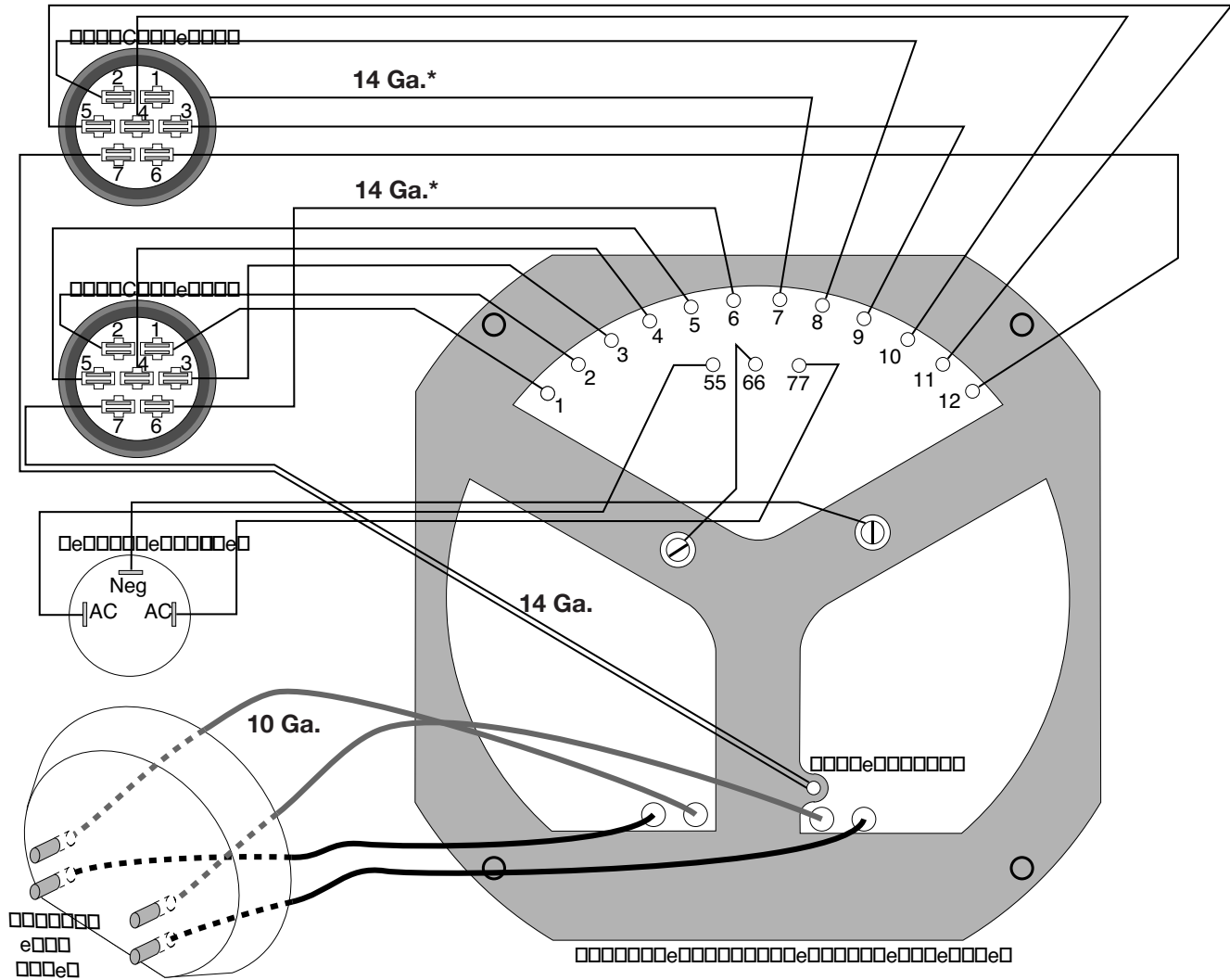

7.5 GPP

Generator Terminals

1 - 2 = 115 Volts @ 1250 VA

Respectively through

11 - 12 = 115 Volts @ 1250 VA

(Pairings of Odd # on Left & Even # on Right.)

Output @ Binding Posts

Black wires 12 Volts @ 500 VA

White wires 12 Volts @ 500 VA

9.0 GPP GENERATOR STATOR WIRING

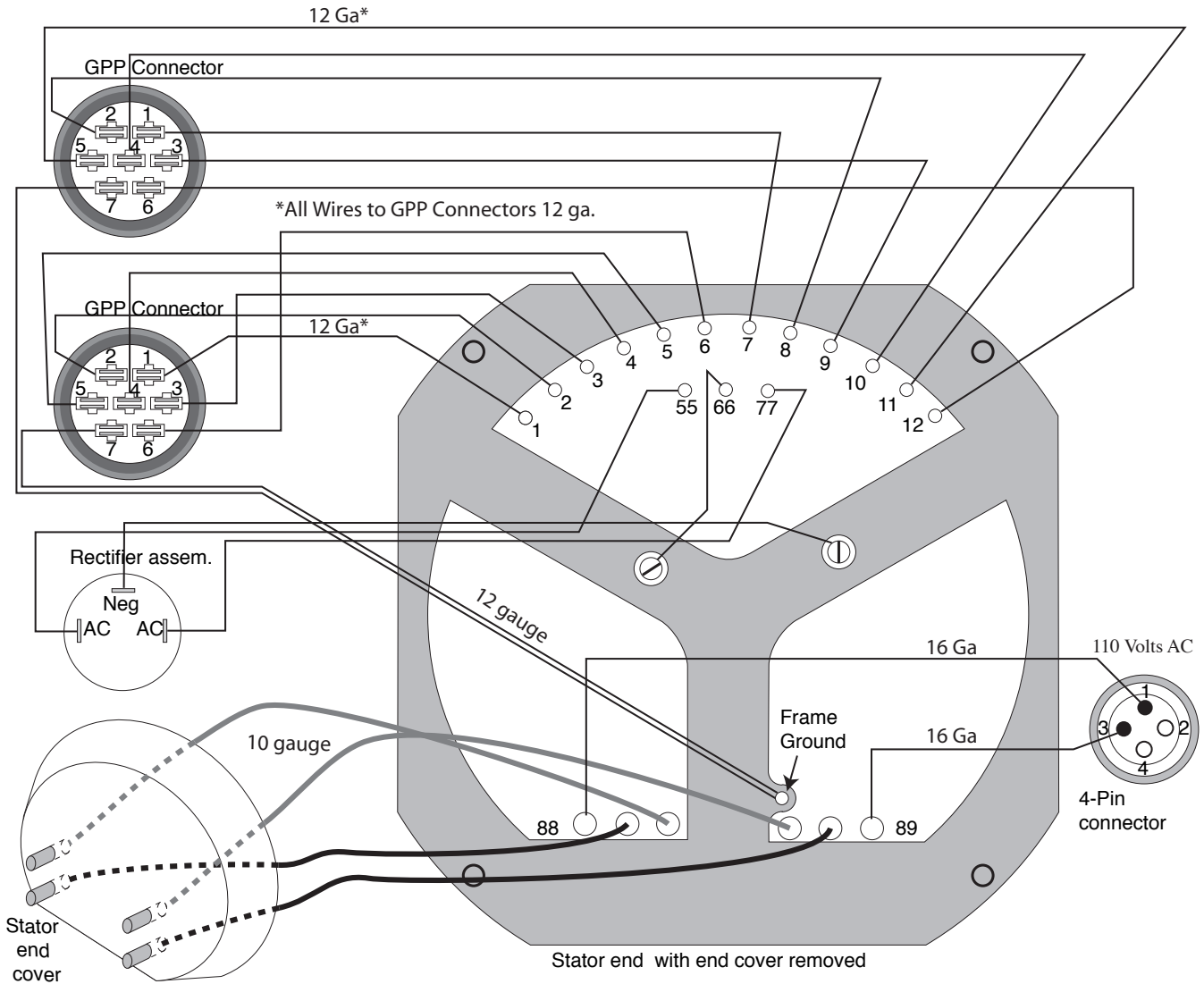

9.0 GPP

Generator Terminals

1 - 2 = 67 Volts @ 1500 VA

Respectively through

11 - 12 = 67 Volts @ 1500 VA

(Pairings of Odd # on Left & Even # on Right.)

Output @ Binding Posts

Black wires 12 Volts @ 500 VA

White wires 12 Volts @ 500 VA

4-Pin Connector

110 Volts AC



SMITH-ROOT, INC.

14014 NE Salmon Creek Ave.

Vancouver, WA 98686 USA

360.573.0202 Voice

360.573.2064 FAX

info@smith-root.com

www.smith-root.com

