

LIFEBOOK T900



Congratulations! You have decided to buy an innovative Fujitsu product.

The latest information about our products, useful tips, updates etc. is available from our website: ["http://ts.fujitsu.com"](http://ts.fujitsu.com)

For automatic driver updates, please go to: ["http://support.de.ts.fujitsu.com/de/support/index.html"](http://support.de.ts.fujitsu.com/de/support/index.html)

Should you have any technical questions, please contact:

- our Hotline/Service Desk (see Service Desk list or visit: ["http://ts.fujitsu.com/support/servicedesk.html"](http://ts.fujitsu.com/support/servicedesk.html))
- Your sales partner
- Your sales office

We hope you really enjoy using your new Fujitsu system.



Copyright

Fujitsu Technology Solutions 2009 12/09

Published by

Fujitsu Technology Solutions
Mies-van-der-Rohe-Straße 8
80807 Munich, Germany

Contact

<http://ts.fujitsu.com/support>

All rights reserved, including the rights to intellectual property. We reserve the right to amend technical data; ability to deliver depends on availability. We do not guarantee that the data and the illustrations are complete, up-to-date or accurate and any liability therefor is excluded. Brand names can be protected trademarks of the respective manufacturer and/or are protected by copyright. Use of these brand names by third parties for their own purposes can constitute an infringement of the rights of the owner. You will find further information at "http://ts.fujitsu.com/terms_of_use.html"

Order No. Fujitsu Technology Solutions GmbH: A26391-K313-Z200-1-7619, edition 1

LIFEBOOK T900

Operating manual

Innovative technology	7
Ports and controls	9
Important notes	13
First-time setup of your device	17
Working with the notebook	20
Security functions	75
Connecting external devices	98
Removing and installing components during servicing	104
Settings in BIOS Setup Utility	109
Troubleshooting and tips	111
Technical data	120
Manufacturer's notes	123
Index	130

Microsoft, MS, Windows XP, Windows Vista and Windows 7 are registered trademarks of the Microsoft Corporation.

Adobe Reader is a trademark of Adobe Systems Incorporated.

MultiMediaCard is a registered trademark of Infineon Technologies AG

Sony and Memory Stick are registered trademarks of Sony Electronics, Inc.

All other trademarks referenced are trademarks or registered trademarks of their respective owners, whose protected rights are acknowledged.

Copyright © Fujitsu Technology Solutions GmbH 2009

All rights reserved, including rights of translation, reproduction by printing, copying or similar methods, in part or in whole.

In the event of violations, perpetrators will be liable to prosecution for damages.

All rights reserved, including rights created by patent grant or registration of a utility model or design.

Subject to availability and technical modifications.

Contents

Innovative technology	7
Further information	7
Notational conventions	8
Ports and controls	9
Important notes	13
Safety notes	13
Additional safety notes for devices with radio components	14
Energy saving	14
Energy saving under Windows	14
Travelling with your notebook	15
Before you travel	15
Notebook: transporting	15
Cleaning the notebook	16
First-time setup of your device	17
Unpacking and checking the device	17
Selecting a location	18
Mains adapter connecting	18
Switching on the device for the first time	19
Working with the notebook	20
Status indicators	20
Opening the notebook	22
Switching on the notebook	22
Programming the ON/OFF switch	23
Different ways to use your notebook	24
From notebook to Tablet PC	24
Select display orientation (portrait or landscape orientation)	27
From Tablet PC to notebook	28
Switching off the notebook	30
Closing the notebook	31
Language selection (Windows XP only)	31
Selecting the language for menu texts	31
Selecting the language for handwriting recognition and keyboard	32
Handwriting recognition under Windows Vista	32
Handwriting recognition under Windows 7	32
LCD screen	33
Ambient light sensor	33
Using a device as a tablet PC	34
Using fingers	34
Using the stylus pen	36
Using the device as a notebook	40
Touchpad and touchpad buttons	40
Keyboard	42
Virtual numeric keypad	44
Country and keyboard settings	44
Key combinations	45
Tablet buttons	47
Key combinations	51
Programming the tablet buttons	52

Webcam	52
Rechargeable battery	53
Charging, caring for and maintaining the battery	53
Removing and installing the battery	54
Batteries with a capacity of 5800 mAh	56
Module	57
Removing a module	57
Installing a module	58
Optical drive	58
Handling data carriers	58
CD/DVD indicator	59
Inserting or removing a data carrier	59
Manual removal (emergency removal)	60
Removing and replacing the casing cover (ventilation slot cover) to get rid of dust	61
Using the power-management features	62
Memory cards	63
Supported formats	63
Inserting the memory card	63
Removing the memory card	64
ExpressCards	65
Inserting the card	65
Removing the card	66
Loudspeakers and microphones	66
SIM card	67
Inserting the SIM card	67
Removing a SIM card	68
Optional wireless components Wireless LAN / BlueTooth / UMTS	69
Switching the wireless components on and off	69
Setting up WLAN access	70
Access via UMTS	70
Ethernet and LAN	70
Port replicator	71
Setting up the port replicator	71
Connect the notebook to the port replicator	72
Switching on the notebook via the port replicator	73
Switching off notebook via Port Replicator	73
Disconnecting the notebook from the port replicator	74
Security functions	75
Brief overview of security functions	76
Configuring the fingerprint sensor	77
Use Kensington Lock	77
Configuring password protection in BIOS Setup Utility	78
Protecting BIOS Setup Utility (supervisor and user password)	78
Password protection for booting of the operating system	79
Password protection for the hard disk	80
SmartCard reader	81
Inserting the SmartCard	81
SmartCard as software protection (SmartCase™ Logon+)	82
SmartCard SystemLock (optional)	83
Access rights of SmartCards	84
SmartCard user groups	85
Installing SystemLock	86

Setting up the first system in a user group or a stand-alone system for use with SystemLock	86
Adding a system to a user group	89
Carrying out administrator functions	91
Remote Access Enabling – F4	93
Switch on the device using SystemLock	94
Start BIOS Setup F2	94
Changing PIN	94
Uninstall SystemLock	94
Error messages	95
Using the security function of the tablet keys	95
Setting the Supervisor password	95
Setting the User password	95
Entering passwords using the tablet buttons	96
Trusted Platform Module (TPM) (device-dependent)	96
Enabling TPM	97
Disabling TPM	97
Connecting external devices	98
Connecting an external monitor	99
HDMI port	100
Connecting USB devices	101
How to remove USB devices correctly	101
Connecting FireWire devices	102
Connecting external audio devices	102
Microphone port / Line In	102
Headphone port	103
Removing and installing components during servicing	104
Notes on installing and removing boards and components	104
Preparing to remove components	105
Installing and removing memory expansion	106
Removing a cover	106
Removing memory modules	107
Installing a memory module	107
Attaching the cover	108
Finishing component removal	108
Settings in BIOS Setup Utility	109
Starting the BIOS Setup Utility	109
Operating BIOS Setup Utility	109
Exiting BIOS Setup Utility	110
Exit Saving Changes - save changes and exit BIOS Setup Utility	110
Exit Discarding Changes – Discard changes and exit BIOS Setup Utility	110
Load Setup Defaults – Copy Standard Entries	110
Discard Changes – Discard changes without exiting the BIOS Setup Utility	110
Save Changes - save changes without exiting the BIOS Setup Utility	110
Save Changes and Power Off	110
Troubleshooting and tips	111
Help if problems occur	112
The notebook's date or time is incorrect	112
Battery indicator does not illuminate	112
When certain characters are entered on the keyboard, only numerals are written	113

The notebook's LCD screen remains blank	113
The LCD screen is difficult to read	113
The external monitor remains blank	113
The external monitor is blank or the image is unstable	114
The cursor does not correctly follow the pen movements	114
Pen input not working	115
The notebook cannot be started	115
The notebook stops working	115
The printer does not print	116
The radio connection to a network does not work	116
The battery discharges too quickly	116
SmartCard reader is not recognised	117
SmartCard PIN forgotten	117
SmartCard lost	117
User and/or supervisor SmartCard lost	117
Acoustic warnings	118
Error messages on the screen	118
Technical data	120
Notebook	120
Port Replicator (optional)	121
Rechargeable battery	122
Mains adapter	122
Manufacturer's notes	123
Energy Star	123
Disposal and recycling	123
Declarations of Conformity	123
Tested safety (TS, depending on the device)	123
CE marking	124
Regulatory notices	124
Regulatory information for notebooks without radio device	124
DOC (Industry CANADA) notices	126
FCC Regulatory information for notebooks with radio device	128
Index	130

Innovative technology

... and ergonomic design make your device a reliable and convenient companion.

The device boots very quickly, is ready for immediate use and offers a particularly long operating time because of its high capacity battery.

With the user-friendly "BIOS Setup Utility" you can control your notebook's hardware and better protect your system against unauthorised access by using the powerful password properties.



Information on the connections and user components of your notebook can be found in ["Ports and controls", Page 9.](#)

Further information







The Windows drivers for your device can be found on our Internet site. The factory installation of your device does not support any other operating system. Fujitsu Technology Solutions accepts no liability whatsoever if any other operating system is used.

Software oriented components of these instructions refer to Microsoft products, if they come within the scope of the delivery.

If you install other software products, pay attention to the operating instructions of the manufacturer.

Notational conventions

	<p>Pay particular attention to text marked with this symbol. Failure to observe these warnings could pose a risk to health, damage the device or lead to loss of data. The warranty will be invalidated if the device becomes defective through failure to observe these warnings.</p>
	<p>Indicates important information for the proper use of the device.</p>
	<p>Indicates an activity that must be performed</p>
	<p>Indicates a result</p>
<p>This font</p>	<p>indicates data entered using the keyboard in a program dialogue or at the command line, e.g. your password (Name123) or a command used to start a program (start.exe)</p>
<p>This font</p>	<p>indicates information that is displayed on the screen by a program, e.g.: Installation is complete.</p>
<p><i>This font</i></p>	<p>indicates</p> <ul style="list-style-type: none"> • terms and texts used in a software interface, e.g.: Click on <i>Save</i> • names of programs or files, e.g. <i>Windows</i> or <i>setup.exe</i>.
<p>"This font"</p>	<p>indicates</p> <ul style="list-style-type: none"> • cross-references to another section, e.g. "Safety information" • cross-references to an external source, e.g. a web address: For more information, go to "http://ts.fujitsu.com" • Names of CDs, DVDs and titles or designations of other materials, e.g.: "CD/DVD Drivers & Utilities" or "Safety" Manual
<p>Key</p>	<p>indicates a key on the keyboard, e.g: F10</p>
<p>This font</p>	<p>indicates terms and texts that are emphasised or highlighted, e.g.: Do not switch off the device</p>

Ports and controls

This chapter presents the individual hardware components of your device. It gives you an overview of the device's indicators and connections. Please familiarise yourself with these components before you start to work with the device.

Notebook open

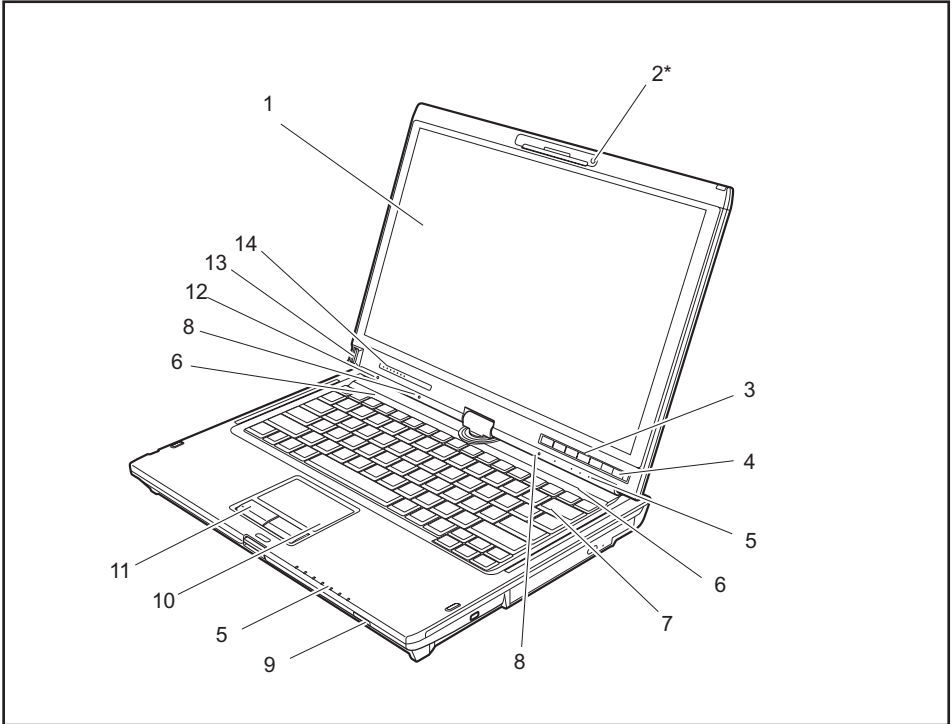

- | | |
|--------------------------------------|---|
| 1 = LCD screen | 8 = Microphone |
| 2 = WebCam 2 mega pixel (* optional) | 9 = ON/OFF switch for wireless components |
| 3 = Tablet buttons | 10 = Touchpad |
| 4 = ON/OFF switch | 11 = Touchpad buttons |
| 5 = Status indicators | 12 = Ambient light sensor |
| 6 = Loudspeakers | 13 = Fingerprint sensor |
| 7 = Keyboard | 14 = Scroll sensor |

Left panel

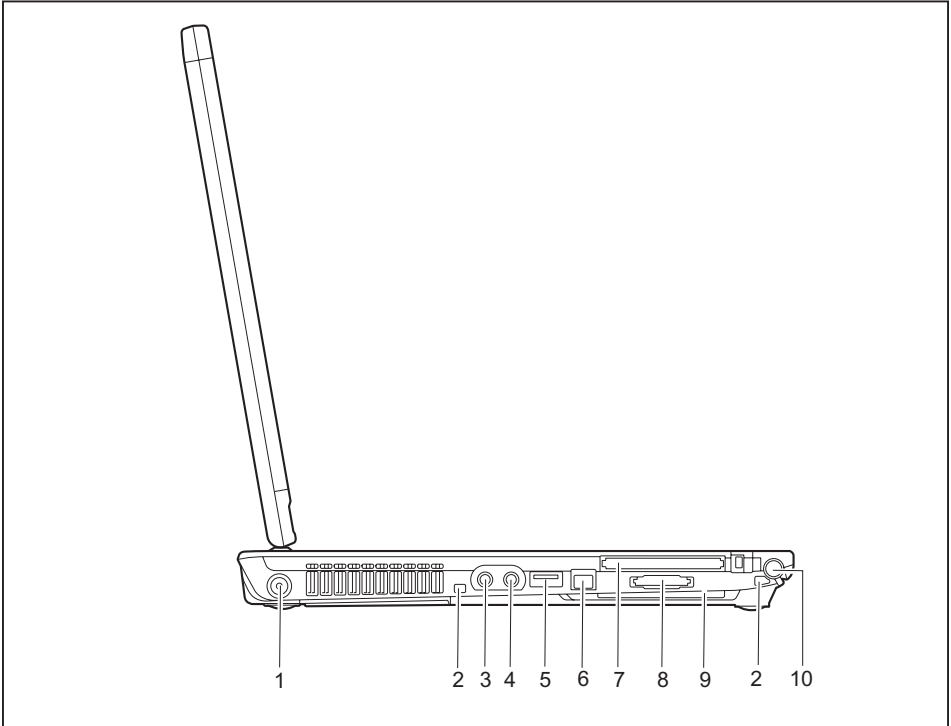

- 1 = DC input connector (DC IN)
- 2 = Attachment eye for the pen cord
- 3 = Microphone jack
- 4 = Headphone port
- 5 = USB port

- 6 = FireWire port
- 7 = ExpressCard slot
- 8 = Memory card slot
- 9 = SmartCard reader
- 10 = Pen slot

Rear

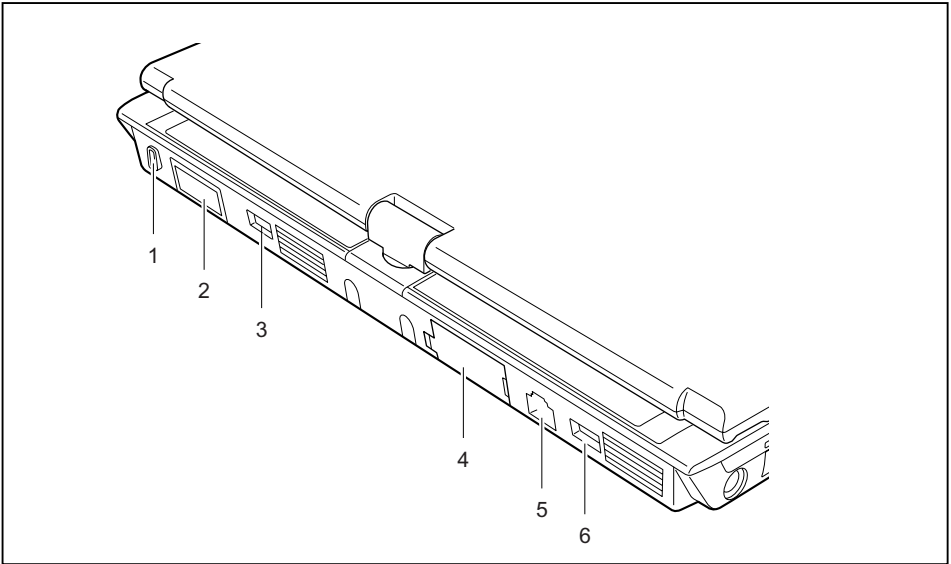

1 = Kensington Lock device

2 = SIM card slot or modem connection
(depending on the device)

3 = USB port

4 = VGA monitor port

5 = LAN port

6 = USB port



The SIM card slot, LAN port and VGA monitor port are protected with covers.

Right-hand side

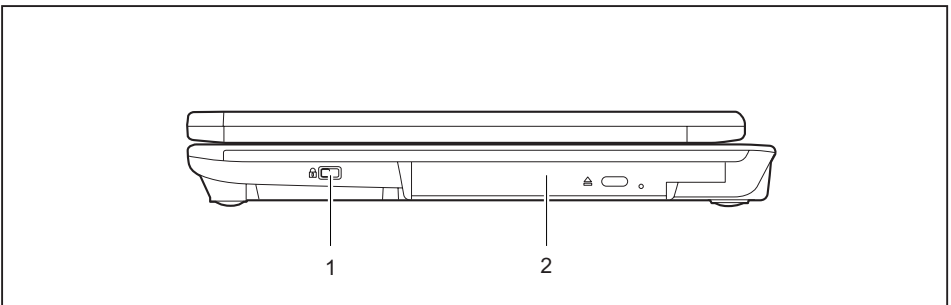

1 = Kensington Lock device

2 = Module bay with optical drive

Underside

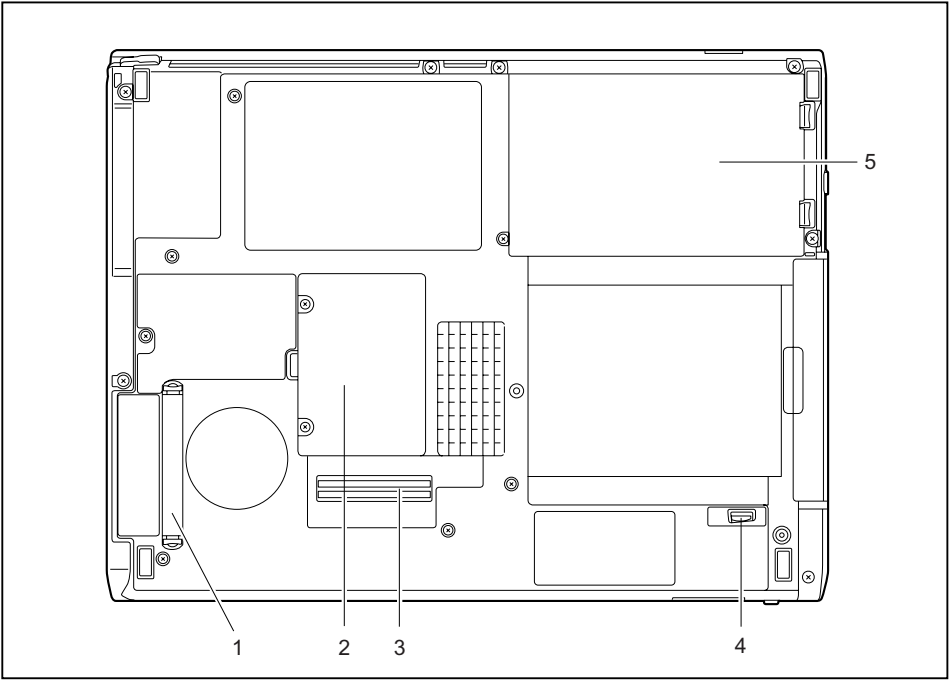

- 1 = Ventilation slot cover
- 2 = Memory service compartment
- 3 = Port for port replicator

- 4 = Eject lever for module in module bay
- 5 = Rechargeable battery

Important notes



This chapter contains essential safety information which must be followed when working with your notebook. Other notes also provide useful information which will help you with your notebook.

Safety notes



Please note the information provided in the "Safety" manual and in the following safety notes.

Please pay special attention to the sections in the manual marked with the symbol on the left.

When connecting and disconnecting cables, observe the relevant notes in this operating manual.

Read the information on the ambient conditions in the ["Technical data", Page 120](#) and ["First-time setup of your device", Page 17](#) before preparing your notebook for use and switching it on for the first time.

When cleaning the device, please observe the relevant notes in the section ["Cleaning the notebook", Page 16](#).

Pay attention to the additional safety notes for devices with wireless components provided in the "Safety" manual.

Please refer to the notes in the chapter ["Removing and installing components during servicing", Page 104](#).

This notebook complies with the relevant safety regulations for data processing equipment. If you have questions about using your notebook in a particular area, please contact your sales outlet or our Hotline/Service Desk.

Additional safety notes for devices with radio components

If a radio component (Wireless LAN, Bluetooth, UMTS) is integrated in your notebook, you must be sure to observe the following safety notes when using your notebook:

- Switch off the radio components when you are in an aircraft or driving in a car.
- Switch off the radio components when you are in a hospital, an operating room or near a medical electronics system. The transmitted radio waves can impair the operation of medical devices.
- Switch off the radio components when you let the device get near flammable gases or into hazardous environments (e.g. petrol station, paintshops), as the transmitted radio waves can cause an explosion or a fire.



For information on how to switch radio components on and off, see chapter ["Switching the wireless components on and off", Page 69](#).

Energy saving

Switch the notebook off when it is not in use. Switch off external, connected devices if you are not using them. If you use the energy saving functions, the notebook uses less energy. You will then be able to work for longer before having to recharge the battery.



Energy efficiency is increased and the environmental impact is reduced. You save money while protecting the environment.

Energy saving under Windows

- ▶ Make use of the power management features (see ["Using the power-management features", Page 62](#)).

Travelling with your notebook

Please observe the points listed below when travelling with your notebook.

Before you travel

- ▶ Back up important data stored on your hard disk.
- ▶ Switch off the radio component for data security reasons. With data traffic via a wireless connection, it is also possible for unauthorised third parties to receive data.



Information on activating data encryption is provided in the documentation for your radio component.

- ▶ If you wish to use your notebook during a flight, first check with the flight attendants if it is OK to do so.

When travelling in other countries

- ▶ If you are travelling abroad, check that the mains adapter can be operated with the local mains voltage. If this is not the case, obtain the appropriate mains adapter for your notebook. Do not use any other voltage converter!
- ▶ Check whether the local mains voltage and the power cable are compatible. If this is not the case, buy a power cable that matches the local conditions.
- ▶ Enquire with the corresponding government office of the country you will be travelling in as to whether you may operate the radio component integrated in your notebook there (see also "[CE marking](#)", [Page 124](#)).

Notebook: transporting



Protect the notebook from severe shocks and extreme temperatures (e.g. direct sunlight in a car).

- ▶ If your device has an optical drive, remove all data media (e.g. CD, DVD) from the drives.
- ▶ Switch the notebook off.
- ▶ Unplug the mains adapter and all external devices from the power socket.
- ▶ Disconnect the mains adapter cable and the data cables for all external devices.
- ▶ Close the LCD screen.
- ▶ To protect against damaging jolts and bumps, use a notebook carrying case to transport your notebook.

Cleaning the notebook



Do not clean any interior parts yourself; leave this job to a service technician.

Only use cleaning products designed for computers. Normal household cleaners and polishes can damage the markings on the keyboard and the device, the paintwork or the notebook itself.

Ensure that no liquid enters the notebook.

The LCD screen very sensitive to scratches. Only clean the display surface with a very soft, slightly damp cloth.

- ▶ Switch the notebook off.
- ▶ In order to prevent accidentally switching the device on, remove the power cable from the mains adaptor and remove the battery (see "[Removing and installing the battery](#)", Page 54).

↳ The surface can be cleaned with a dry cloth. If particularly dirty, use a cloth which has been moistened in mild domestic detergent and then carefully wrung out.

To clean the keyboard and the touchpad, if available, you can use disinfectant wipes.

Ensure that no liquid enters the device.

First-time setup of your device



Please read the chapter "[Important notes](#)", [Page 13](#).

If your device is equipped with a Windows operating system, the necessary hardware drivers and supplied software are already pre-installed.

Before you switch on the device for the first time, connect it to the mains voltage using the mains adapter, see "[Mains adapter connecting](#)", [Page 18](#). The mains adapter must be connected during the entire installation process.

A system test is performed when your device is first switched on. Various messages can appear. The display may remain dark for a short time or may flicker.

Please follow the instructions on the screen.

NEVER switch off your device during the first-time setup process.

On delivery, the battery can be found in the battery compartment or in the accessories kit. The battery must be charged if you want to operate your device using the battery.

When used on the move, the built-in battery provides the device with the necessary power. You can increase the operating time by using the available energy-saving functions.

For instructions on how to connect external devices (e.g. mouse, printer) to your device, please refer to the operating manual for your device.

Unpacking and checking the device



Should you discover any damage that occurred during transportation, notify your local sales outlet immediately!

- ▶ Unpack all the individual parts.
- ▶ Check your device for any visible damage which may have occurred during transportation.



You may need the packaging in the future, if you need to transport your device.

Selecting a location



Select a suitable location for the device before setting it up. Follow the instructions below when doing so:

- Never place the device or the mains adapter on a heat-sensitive surface. The surface could be damaged as a result.
- Never place the device on a soft surface (e.g. carpeting, upholstered furniture, bed). This can block the air vents and cause overheating and damage.
- The underside of the device heats up during normal operation. Prolonged contact with the skin may become unpleasant or even result in burns.
- Place the device on a stable, flat, non-slippery surface. Please note that the rubber feet of the device may mark certain types of delicate surfaces.
- Keep other objects at least 100 mm away from the device and its mains adapter to ensure adequate ventilation.
- Never cover the ventilation slots of the device.
- Do not expose the device to extreme environmental conditions. Protect the device from dust, humidity, and heat.

Mains adapter connecting



Observe the safety precautions in the enclosed "Safety" manual.

The supplied power cable conforms to the requirements of the country in which you purchased your device. Make sure that the power cable is approved for use in the country in which you intend to use it.

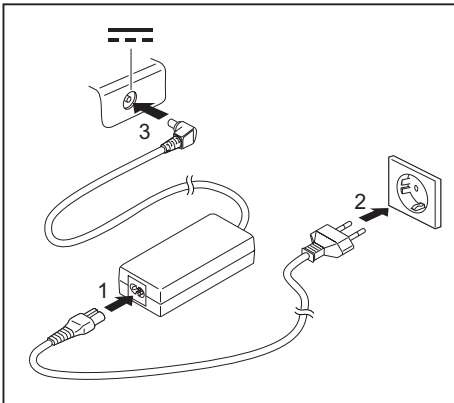

- ▶ Connect the power cable (1) to the mains adapter.
- ▶ Plug the mains cable (2) into a mains outlet.
- ▶ Connect the mains adapter cable (3) to the DC jack (DC IN) of the device.

Switching on the device for the first time



On devices with ON/OFF switch for wireless components: Slide the ON/OFF switch for wireless components to the ON position before switching on the device.

When you switch on the device for the first time, the supplied software is installed and configured. Because this procedure must not be interrupted, you should set aside enough time for it to be fully completed and connect the device to the mains using the mains adapter.

During the installation process, **DO NOT** restart the device unless you are requested to do so!

To make it easier to use your device for the first time, the operating system is pre-installed on the hard disk.

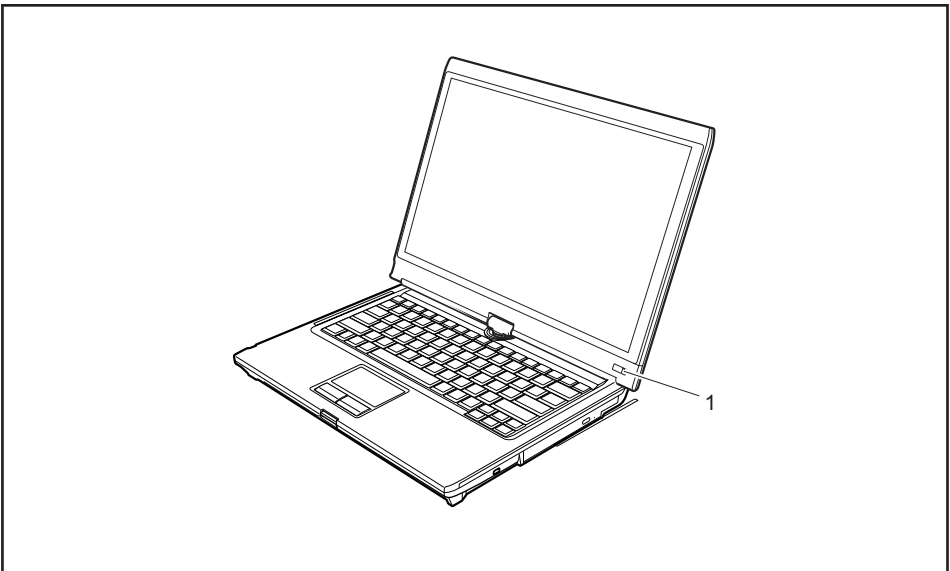

- ▶ Slide the ON/OFF switch (1) to the right to switch on the notebook.
- ↳ The ON/OFF switch returns automatically to its original position.
- ▶ During installation, follow the instructions on screen.



If a Windows operating system is installed on your device, you will find more information on the system and drivers, help programmes, updates, manuals etc. on the device or on the Internet at ["http://ts.fujitsu.com/support"](http://ts.fujitsu.com/support).

Working with the notebook

This chapter describes the basics for operating your notebook. Please read the chapter entitled "[Connecting external devices](#)", [Page 98](#) for instructions on how to connect devices such as a mouse and a printer to the notebook.









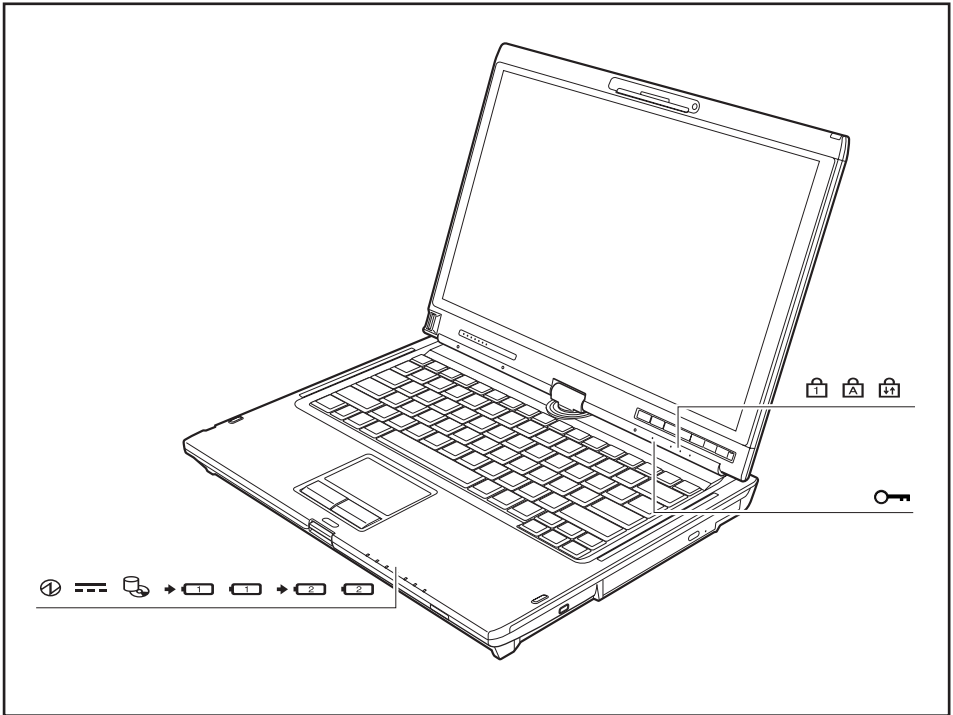

Please refer to the notes in "[Important notes](#)", [Page 13](#).

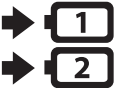
Status indicators

The status indicators provide information about the status of the power supply, the drives and the keyboard functions etc.



Status displays	Description
	<p>Power-on indicator</p> <ul style="list-style-type: none"> Indicator is illuminated: The notebook is switched on. Indicator flashes: The notebook is in sleep mode (Save-to-RAM). The indicator is not illuminated: The notebook is switched off or in Save-to-Disk mode.
	<p>Power supply indicator</p> <p>Indicator is illuminated: The mains adapter is supplying power to the notebook.</p>
	<p>Drive indicator</p> <p>Indicator is illuminated: The hard disk drive or the CD/DVD in the optical drive of the notebook is being accessed.</p>
	<p>Battery charging indicator</p> <p>This description applies to both batteries.</p> <p>The battery charging indicator shows whether a battery is installed and being charged.</p>
	<p>Battery indicator</p> <p>This description applies to both batteries.</p> <p>The battery indicator shows the state of charge of the installed battery.</p> <ul style="list-style-type: none"> Indicator is lit blue: The battery is between 50 % and 100 % charged. The indicator is lit orange: The battery is between 13 % and 49 % charged. The indicator is lit red: The battery is between 0 % and 12 % charged. The indicator flashes orange: The battery state of charge is being checked (for four seconds after battery installation). The indicator flashes red: The battery is faulty. The indicator is not lit: There is no battery installed. <p>Note: If you use batteries with a capacity of 5800 mAh, you can also check the charge condition on the battery itself.</p>
	<p>Num Lock indicator</p> <p>Indicator is lit: The [Num] key has been pressed. The virtual numerical keypad is activated. You can output the characters indicated on the upper right of the keys.</p>
	<p>Caps Lock indicator</p> <p>Indicator is lit: The Caps Lock key has been pressed. All letters will be output as uppercase letters. In the case of keys labelled several times, the character printed on the upper left of the key will appear when that key is pressed.</p>
	<p>Scroll Lock indicator</p> <p>Indicator is lit: The key combination [Fn] + [Scr] has been pressed. The effect that this key has varies between applications.</p>
	<p>Lock Workstation indicator</p> <p>The indicator is illuminated: The security functions of the Notebook have locked your workstation.</p>

Opening the notebook

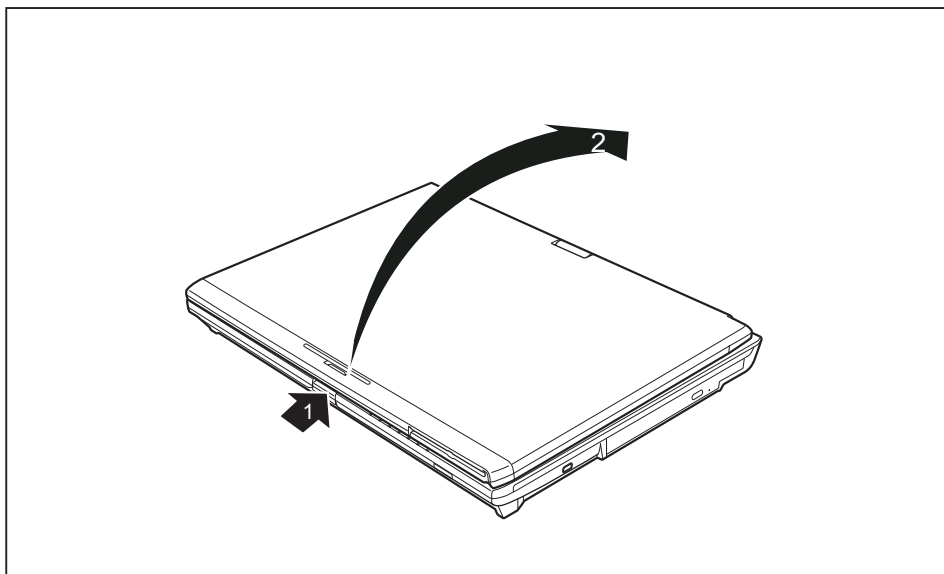

- ▶ Press the release button (1), and unfold the LCD screen upwards (2).

Switching on the notebook

- ▶ Slide the ON/OFF switch (1) to the right to switch on the notebook.
 - ↳ The ON/OFF switch returns automatically to its original position.
The power-on indicator (2) lights.

Programming the ON/OFF switch

You can program the ON/OFF switch:

Operating system	Menu
Windows XP	<i>Start - (Settings) - Control panel - Performance and Maintenance - Power options - Advanced</i>
Windows Vista	<i>Start - (Settings) - Control panel - Mobile PC - Power options</i>
Windows 7	<i>Start - (Settings) - Control panel - System and Security - Power options</i>



If you have assigned a password, you must enter this when requested to do so, in order to start the operating system. Detailed information can be found in the chapter ["Security functions", Page 75](#).

Different ways to use your notebook

During your daily work, you can use your notebook as a tablet PC or as a notebook, just as you wish. The "conversion" is lightning fast and effortless.



Note the direction of rotation in the following description! No guarantee claims can be met for damage caused by turning in the wrong direction.

You must note that the display cannot be turned completely on its own axis!

From notebook to Tablet PC

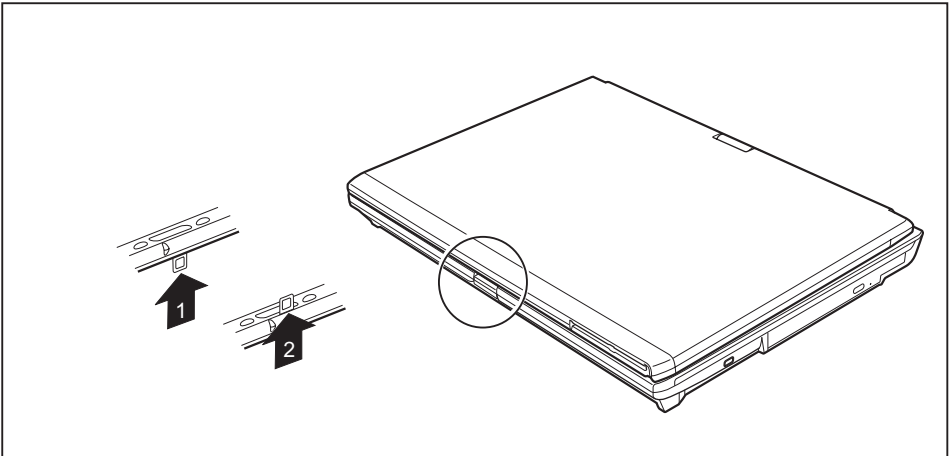

- ▶ Press the release button, and unfold the LCD screen upwards slightly.
- ▶ Rotate the hook from position 1 to position 2.

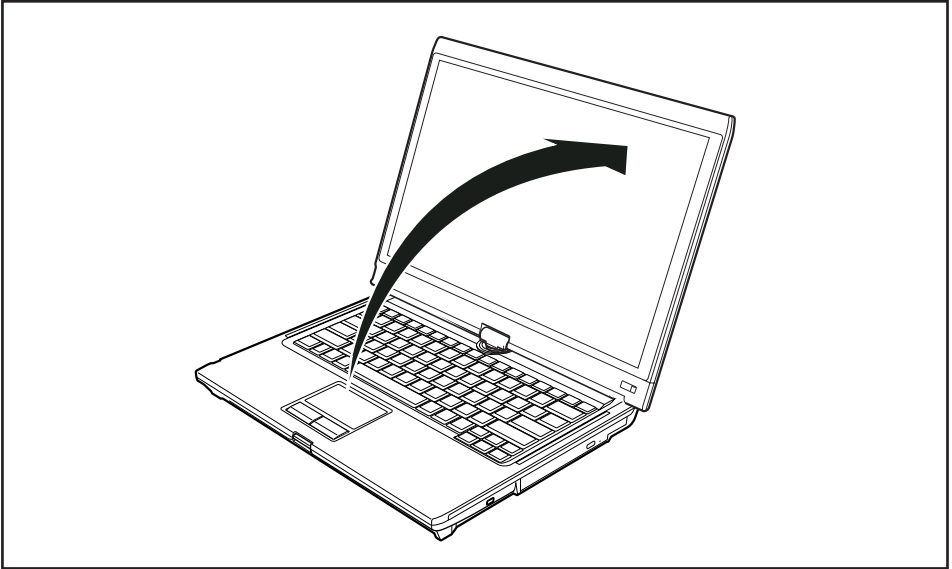

- ▶ Raise the screen into a vertical position.

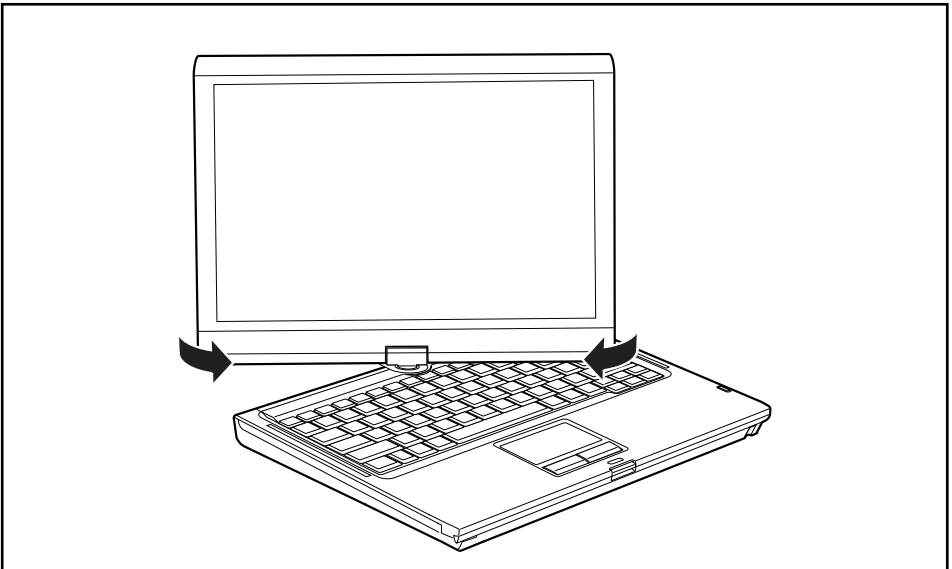

- ▶ Hold the screen as low as possible on both sides. Turn the screen to the left or right in the direction of the arrow. At first you will feel some slight resistance, then it will turn easily and without friction.

- ▶ Rotate the display further until it has turned 180° and the hinge latches in.

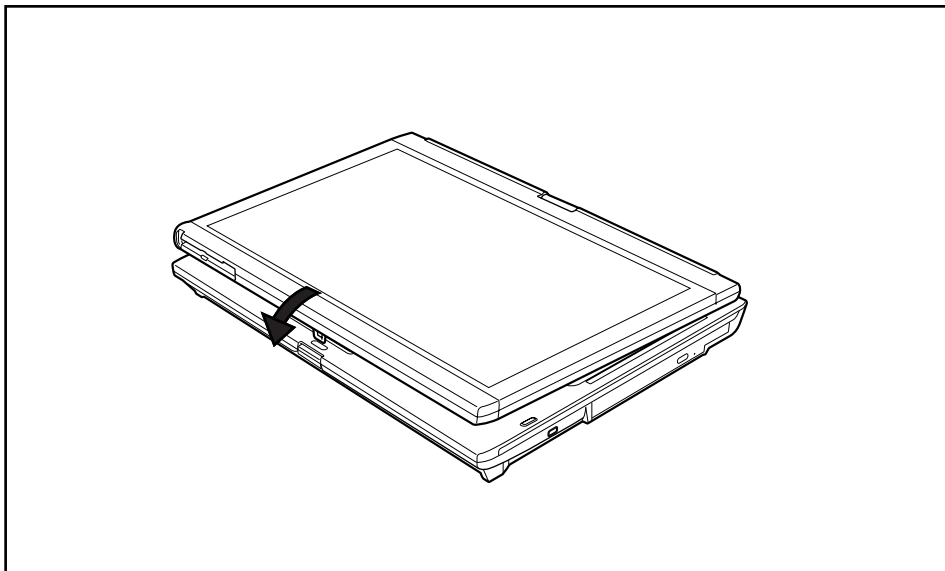

- ▶ Now fold the screen down until the back of the screen is flat on top of the keyboard and the hook latches in.
- ↳ The screen is now secured in the tablet position.

Select display orientation (portrait or landscape orientation)

Sie haben die Wahl, ob Sie den Bildschirm im Hochformat oder Querformat verwenden möchten. Zum Umschalten von der einen zur anderen Bildschirmausrichtung drücken Sie die Tablet-Taste **Fn**.

The display switches automatically to portrait layout when the device is used as a Tablet PC and to landscape layout when it is used as a notebook.



Windows XP

You can change these settings in the Fujitsu menu or under *Start - (Settings -) Control Panel - Tablet and Pen Settings*.

Windows Vista

You can change these settings in the Fujitsu menu or under *Start - (Settings -) Control Panel - Mobile PC - Tablet PC - Settings*.

Windows 7

You can change these settings in the Fujitsu menu or under *Start - (Settings -) Control Panel - Hardware and Sound - Display - Settings*.



Profiles for operating in different screen orientations are found under *Fujitsu Tablet Control* in the Fujitsu menu. These profiles have preset standard configurations that can be modified as desired.

These settings not only affect the monitor settings on the Tablet PC, but also any external monitors that may be connected.

From Tablet PC to notebook

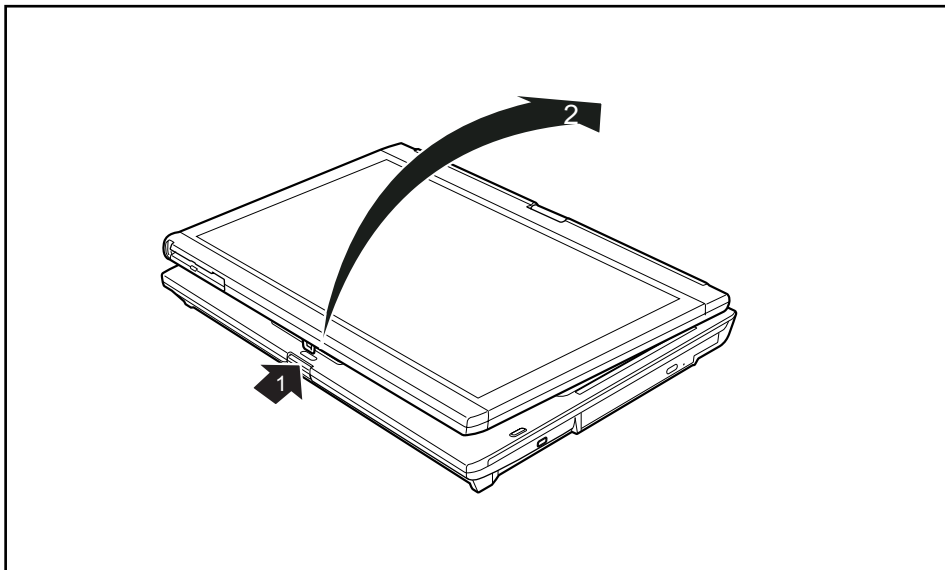

- ▶ Press the release button (1), and unfold the LCD screen upwards (2).
- ▶ Open the display until it is in the vertical position.



Note the direction of rotation in the following description! No guarantee claims can be met for damage caused by turning in the wrong direction.

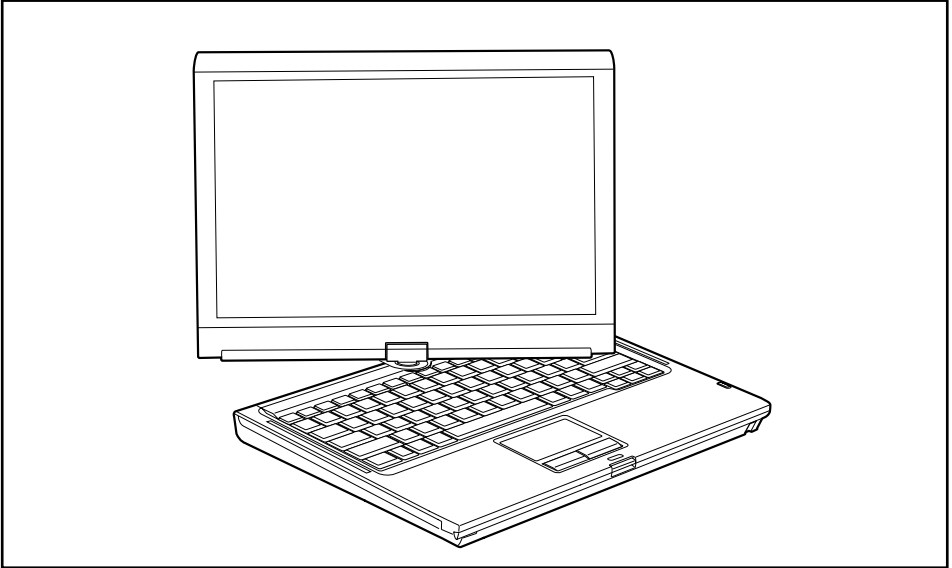

- ▶ Hold the display on both sides as far down as possible and then turn the display. It turns easily and without resistance.
- ▶ Turn or move the display further until it has turned 180° and the hinge latches in.

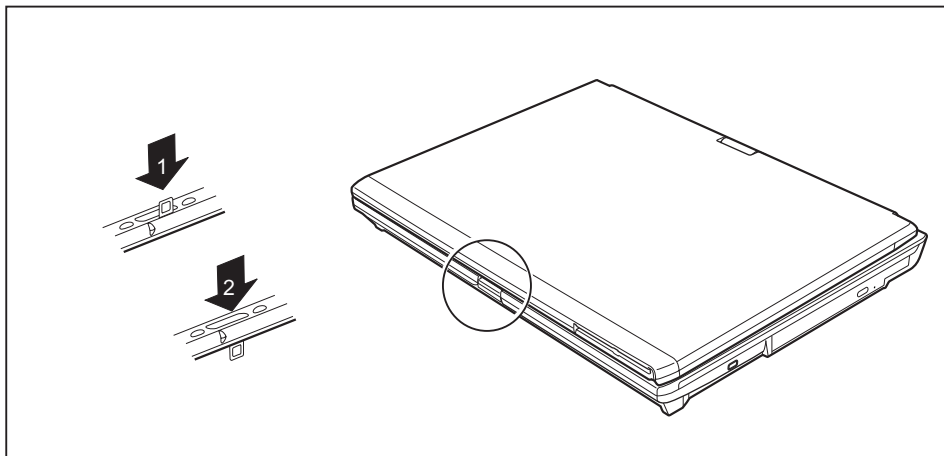

- ▶ To be able to shut the notebook again, rotate the hook from position (1) to position (2).

Switching off the notebook

- ▶ Close all applications and then shut down the operating system (please see the "Operating System Manual").
- ▶ Slide the ON/OFF switch towards the right.
- ↳ The ON/OFF switch returns automatically to its original position.

Closing the notebook

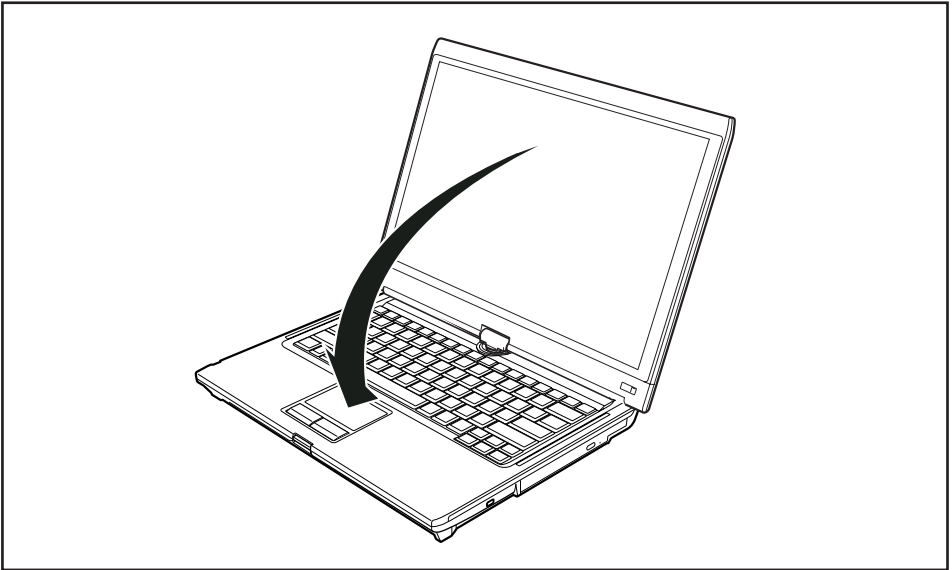

- ▶ Fold the LCD screen down onto the lower part of the notebook until you feel it lock into place.

Language selection (Windows XP only)

Your notebook is supplied with the Windows XP Tablet PC 2005 Edition operating system as a single or multi-language version (according to your preference).

In the single language version, you are presented with two handwriting recognition input areas, one for the operating system language and one for English.

In the multi-language version, you have the option of setting the language of the menu texts and the keyboard as well as that of the handwriting recognition.



With the multi-language models, the default language set for the menu texts, keyboard and handwriting recognition is English.

Selecting the language for menu texts

- ▶ Click on *Control Panel – Date, Time, Language and Regional Options – Language and Regional options*.
- ▶ Select the desired language on the *Regional Options* tab.

Selecting the language for handwriting recognition and keyboard

- ▶ Click on *Control Panel – Date, Time, Language and Regional Options – Language and Regional options*.
- ▶ Select the *Languages* tab.
- ▶ In the *Text services and input languages* field, click on the *Details* button.
- ▶ In the next dialog window, select the *Settings* register card and click the *Add* button in the *Installed Services* field.
- ▶ In the next dialog window, select the desired *Input area schema*.
- ↳ You can now decide which functions (keyboard layout, handwriting recognition, etc.) the selected input area schema is to be activated for.
- ▶ Mark the desired functions and then confirm your entries by clicking the *OK* button.
- ↳ You will find further information in the Windows XP Tablet PC 2005 Edition operating system help.

Handwriting recognition under Windows Vista

Handwriting recognition under Windows Vista currently supports the following languages:

English, German, French, Italian, Japanese, Korean, Chinese (traditional and simplified), Dutch, Portuguese and Brazilian.

Handwriting recognition under Windows 7

Handwriting recognition under Windows 7 currently supports the following languages:

English, German, French, Italian, Japanese, Korean, Chinese (traditional and simplified), Dutch, Portuguese, Spanish, Brazilian, Norwegian (Bokmål and Nynorsk), Swedish, Finnish, Danish, Polish, Rumanian, Serbian (Cyrillic and Latin script), Catalan, Russian, Czech and Croatian.

LCD screen

High-quality TFT displays are installed in notebooks from Fujitsu Technology Solutions GmbH. For technical reasons, TFT monitors are manufactured for a specific resolution. An optimal, clear picture can only be ensured with the correct resolution intended for the relevant TFT monitor. A monitor resolution which differs from the specification can result in an unclear picture.

The screen resolution of the LCD monitor of your notebook is optimally set at the factory.

The standard of production techniques today cannot guarantee an absolutely fault-free screen display. A few isolated constant lit or unlit pixels (picture elements) may be present. The maximum permitted number of pixels faults is stipulated in the international standard ISO 9241-3 (Class II).

Example:

A monitor with a resolution of 1280 x 800 has $1280 \times 800 = 1024000$ pixels. Each pixel consists of three subpixels (red, green and blue), so there are almost 3 million subpixels in total. According to ISO 9241-3 (class II), a maximum of 2 light and 2 dark pixels and an additional 5 light or 10 dark subpixels or a corresponding mix may be defective (1 light subpixel counts as 2 dark subpixels).

Pixel	A pixel consists of 3 subpixels, normally red, green and blue. A pixel is the smallest element that can be generated by complete functionality of the display.
Subpixel	A subpixel is a separately addressable internal structure within a pixel that enhances the pixel function.
Cluster	A cluster contains two or more defective pixels or subpixels in a 5 x 5 pixel block.

Background lighting

TFT monitors are operated with background lighting. The luminosity of the background lighting can decrease during the period of use of the notebook. However, you can set the brightness of your monitor individually.

Synchronising the display on the LCD screen and an external monitor

For more information, please refer to the chapter ["Key combinations", Page 45](#) under "Display output, switch between".

Ambient light sensor

If your notebook was shipped with the *Windows 7* operating system, the screen brightness is regulated by means of the ambient light sensor and depending on the respective light conditions. This results in optimum readability and longer battery life at the same time.

Using a device as a tablet PC

You can execute commands as follows:

- using the stylus pen (supplied with your device).
- using your finger (only with Dual Digitizer technology).

Using fingers

You can execute certain commands by using your finger tip on the touchscreen of your device.



Everything which you can select or activate using your finger tip can also be selected or activated using the stylus pen.

Calibrate the Dual Digitizer for finger-based operation of the device.



Please see the appropriate supplementary sheet for instructions on how to calibrate your device to use Dual Digitizer Technology.

Please note: There are separate calibration programs available for calibrating the stylus pen and for calibrating finger-based operation. In each case, use the calibration tool described in the supplementary sheet. Do not use the calibration tool for the stylus pen to calibrate finger-based operation.

Selecting menu options (click with the left mouse button)

- ▶ Touch the menu option with your finger tip.

Starting programs (double-click with the left mouse button)

- ▶ Briefly touch the program icon twice with your finger tip.

Moving objects/windows (drag while holding the left mouse button pressed)

- ▶ Place your finger tip directly on the object/window, hold it pressed against the screen and move the desired object/window.

Opening a context menu (click with the right mouse button)

- ▶ Touch the desired item once with your finger tip.
- ↳ The context menu appears.

Moving the cursor

- ▶ Place your finger tip on the screen and move your finger in the direction required.

Scrolling

- ▶ Use one finger to quickly stroke across the screen upwards, downwards, left or right to navigate through the document or to quickly page through the document.

Dragging

- ▶ Place your finger on an item on the screen and then move your finger without removing it from the display; this will drag the item to another position. You can also use this movement to page slowly through documents.

Contracting and extending

- ▶ Touch the screen at two edges of an area with two fingers spread apart, then slide the fingers together to make the area smaller. Spread the fingers to make the area larger.

Rotating

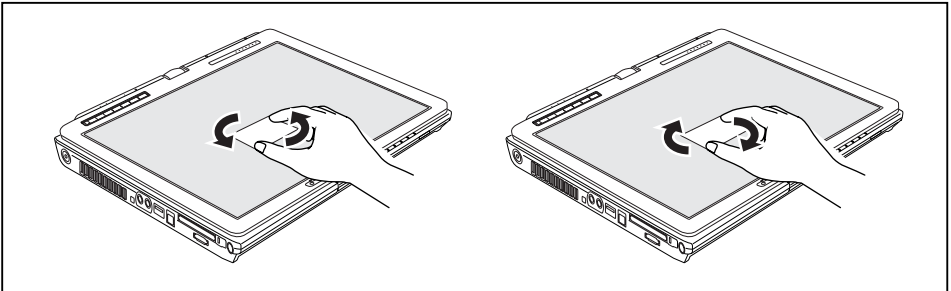

- ▶ Touch two corners of a picture on the screen, then turn the picture clockwise or counter-clockwise at the corners by using your fingers.

Enlarging a view

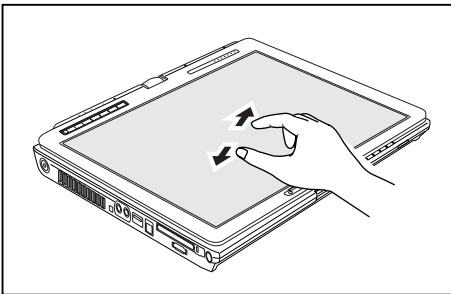

- ▶ Put two fingers on the touch screen and move them apart.

Reducing a view

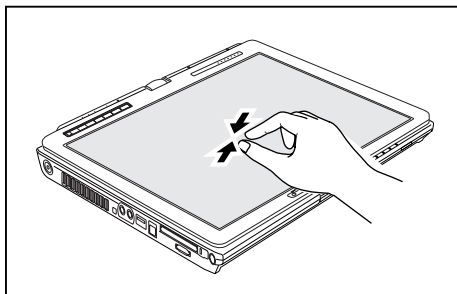

- ▶ Put two fingers on the touch screen and move them towards each other.

Using the stylus pen

You can use the pen on your notebook as an electronic writing implement to select items and to navigate through menu options and programs. Programs that support handwriting recognition also allow you to write characters directly on the screen with the pen. You can also use the pen as a drawing tool.

The notebook pen is retained securely in the pen slot. This ensures that the pen cannot be lost, regardless of whether you use the notebook as a Tablet PC or as a notebook, or transport it while travelling. Always replace the pen in its slot when you are not using it.

The notebook is supplied with a pen cord which you can attach to the eyelets on the pen and on the notebook.



Only use the pen provided with your notebook. Do not use substitute pen tips that were not specially designed for your notebook. Replace the stylus tip if it is worn. The warranty does not cover a scratched screen.

While writing, you should take care not to scratch the surface of the display (e.g. with a wristwatch or bracelet).

i

The pen of your notebook is an electronic instrument which can be damaged if used incorrectly. Handle the pen with care.

The following list contains guidelines for proper pen handling:

- Do not gesture with the pen.
- Do not use the pen as a pointer.
- Never use the pen on any other surface than the screen of your notebook.
- Do not try to turn the thumb grip on the pen. The thumb grip is used to place the pen in its slot and to take it out of the slot.
- Never store the pen with the tip bearing the weight of the pen (e.g. with the tip down in a pen holder). If the pen is stored with the tip pointing down, this may have an adverse effect on the pen mechanism (particularly under high temperatures). In this case the pen tip may react as though it is constantly being pressed down. To avoid damage, the pen should be stored in the pen slot when not in use.

The pen can be influenced by electromagnetic fields (cursor quivers or jumps). There may be a few areas on the screen where the cursor quivers slightly in spite of pressing the pen down firmly.

The screen responds to entries made with the tip of the finger or the pen when the tip of the finger or the pen is in direct contact with the screen.

You can use the pen to perform all the functions for which you would otherwise use a mouse. In addition, you can conveniently delete hand-written pen entries using the pen.

Handling	Mouse	Pen
Selecting menu entries	Click with the left-hand mouse button.	Touch the menu entry with the pen tip.
Starting programs	Double click with the left-hand mouse button.	Briefly touch the program icon twice with the pen tip.
Moving objects/windows	Drag with the left-hand mouse button held pressed.	Place the pen tip directly on the object/window. Hold the pen tip pressed against the screen. Move the desired object/window.
Opening a context menu	Click with the right-hand mouse button.	Touch the desired element with the pen and leave the pen on the element for a moment.
Moving the cursor	-	Place the pen tip directly on the screen.

Setting the pen

Operating system	Menu
Windows XP	You can access the various pen settings (for instance the pressure sensitivity) under <i>Fujitsu Pen Settings</i> or <i>Tablet and Pen Settings</i> in the Control Panel.
Windows Vista	<i>You can access the various pen settings under Start - (Settings) Control Panel – Mobile PC – Pen and Input Device or Tablet PC Settings</i> in the Control Panel.
Windows 7	Under <i>Hardware and Sound – Pen and Input Devices</i> in the Control Panel you can change various settings for the pen (assignment and function of the rocker button).

Calibrating the pen

Before using the pen for the first time, you should calibrate it so that the cursor follows the movements of the pen as accurately as possible. You should also always repeat the calibration if the co-ordination between the pen and cursor movement deteriorates.



Please note: There are separate calibration programs available for calibrating the stylus pen and for calibrating finger-based operation. In each case, use the calibration tool described in the supplementary sheet. Do not use the calibration tool for the stylus pen to calibrate finger-based operation.

Operating system	Menu
Windows XP	To calibrate, run the <i>Tablet and Pen Settings</i> function in the Control Panel. You need to calibrate both portrait and landscape formats.
Windows Vista	To calibrate, run the <i>Tablet PC Settings</i> function in the Control Panel. You need to calibrate both portrait and landscape formats.
Windows 7	To calibrate, run the <i>Hardware and Sound / Tablet PC Settings</i> function in the Control Panel. You need to calibrate both portrait and landscape formats.

Replacing the pen tip

With use, the pen tip may become worn or may pick up foreign particles that can scratch the screen. A damaged or worn tip may not move freely over the screen, causing unpredictable results when using the pen.

If your pen exhibits these problems, you should replace the pen tip. To do this, use the supplied tool (1).

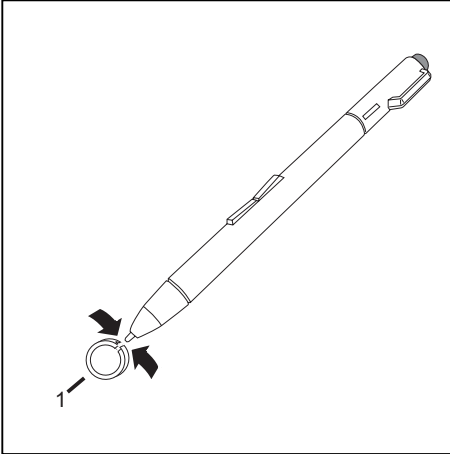

- ▶ To remove the tip, position the tip in the gap between the two ends of the tool supplied.
- ▶ Pinch the two ends of the supplied tool together so that the tip is firmly clasped, then pull it from the barrel.
- ▶ Replace the tip of the pen with one of the spare tips supplied with your pen. Insert the flat end of the tip into the barrel and exerting gentle pressure, push it in until it is firmly in place.

i

If the tip is worn or damaged, discard it.

Installing a pen cord

You should attach the pen with a pen cord to prevent accidentally dropping or losing it.

- ▶ Attach the end of the pen cord with the smaller loop to your pen.
- ▶ Attach the end of the pen cord with the larger loop to your notebook.

Using the device as a notebook

Touchpad and touchpad buttons



Keep the touchpad clean. Protect it from dirt, liquids and grease.

Do not use the touchpad if your fingers are dirty.

Do not rest heavy objects (e.g. books) on the touchpad or the touchpad buttons.

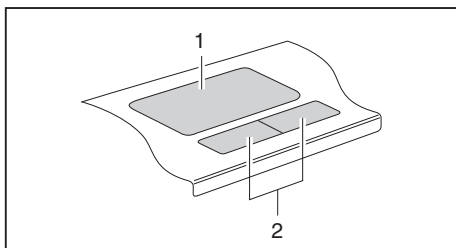

1 = Touchpad

2 = Touchpad buttons

The touchpad enables you to move the mouse pointer on the screen.

The touchpad buttons allow you to select and execute commands. They correspond to the buttons on a conventional mouse.



You can use a key combination to disable the touchpad, to avoid accidentally moving the pointer on the screen (see also ["Key combinations", Page 45](#)).

Moving the pointer

- ▶ Move your finger on the touchpad.
- ↳ The pointer will move.

Selecting an item

- ▶ Move the pointer to the item you wish to select.
- ▶ Tap the touchpad once or press the left button once.
- ↳ The item is selected.

Executing commands

- ▶ Move the pointer to the field you wish to select.
- ▶ Tap the touchpad twice or press the left button twice.
- ↳ The command is executed.

Dragging items

- ▶ Select the desired item.
- ▶ Press and hold the left button and drag the item to the desired position with the finger on the touchpad.
- ↳ The item will be moved.

Switching the Touchpad on and off



You can switch the Touchpad on and off using a key combination, see ["Key combinations", Page 45](#).

Keyboard



The keyboard of your notebook is subject to continuous wear through normal use. The key markings are especially prone to wear. The key markings are liable to wear away over the life of the notebook.

The keyboard has been designed to provide all the functions of an enhanced keyboard. Some enhanced keyboard functions are mapped with key combinations.

The following description of keys refers to Windows. Additional functions supported by the keys are described in the relevant manuals supplied with your application programs.





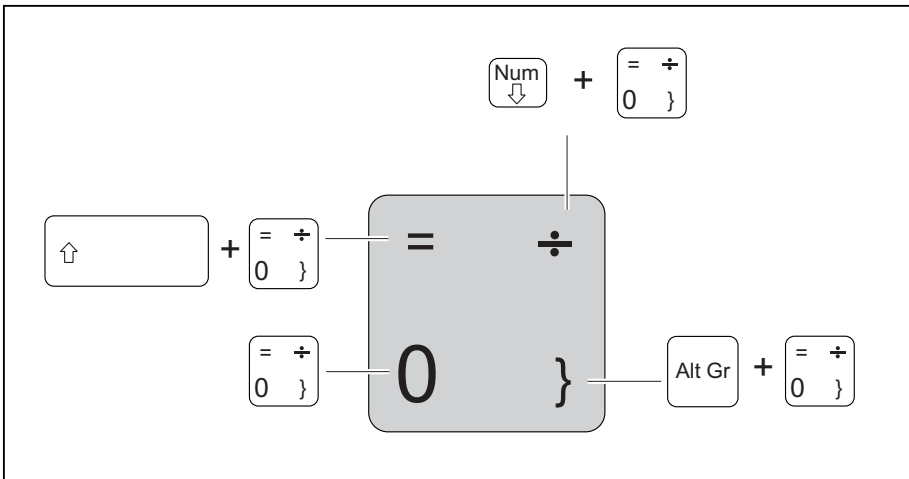

The figure below shows how to access the different characters on keys with overlaid functions. The example applies when the Caps Lock key has not been activated.

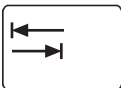

The illustrations shown below may differ from your actual device.

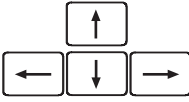

Key	Description
	Backspace key The Backspace key deletes the character to the left of the cursor.
	Tab key The Tab key moves the cursor to the next tab stop.

Key	Description
	<p>Enter key (return) The Enter key terminates a command line. The command you have entered is executed when you press this key.</p>
	<p>Caps Lock key The Caps Lock key activates the Caps Lock mode, and the corresponding icon is displayed in the Windows information area. In Caps Lock mode, all of the characters you type appear in upper case. In the case of overlay keys, the character printed on the upper left of the key will appear when that key is pressed. To cancel the Caps Lock function, simply press the Caps Lock key again.</p>
	<p>Shift key The Shift key causes uppercase characters to appear. In the case of overlay keys, the character printed on the upper left of the key appears when that key is pressed.</p>
	<p>Fn button The [Fn] key enables the special functions indicated on overlay keys (see "Key combinations", Page 45).</p>
	<p>Cursor keys The cursor keys move the cursor in the direction of the arrow, i.e. up, down, left, or right.</p>
	<p>Start key The Start key opens the Windows Start menu.</p>
	<p>Menu key The Menu key invokes the menu for the marked item.</p>

Virtual numeric keypad

To provide the convenience of a numeric keypad, your keyboard is equipped with a virtual numeric keypad. The special keys of the virtual numeric keypad are recognisable by the numbers and symbols printed in the upper right corner of each key. If you have switched on the virtual numeric keypad, you can output the characters shown on the upper right of the keys.



The keyboard layout shown below may differ from your actual device.

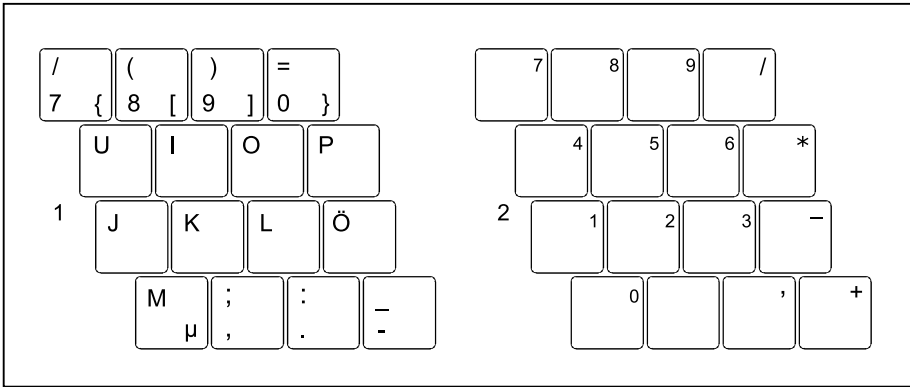

1 = Valid characters when the Num key is not activated

2 = Valid characters when the Num is activated

Further information about the status indicators can be found in chapter ["Status indicators", Page 20](#).

Country and keyboard settings

If you want to change the country and keyboard settings, proceed as follows:













- ▶ Enter the settings by clicking *Start – (Settings) – Control Panel – Time, Regional and Language Options*.

Key combinations

The key combinations described below apply when using Microsoft Windows operating systems. Some of the following key combinations may not function in other operating systems or with certain device drivers.

Key combinations are entered as follows:

- ▶ Press the first key in the combination and keep it pressed.
- ▶ While holding the first key down, press the other key or keys in the combination.

Combination	Description
 + 	<p>Switching the loudspeakers on/off This key combination switches the integrated loudspeakers on and off.</p>
 + 	<p>Enable/disable touchpad This key combination enables and disables the touchpad.</p>
 + 	<p>Decrease screen brightness This key combination decreases the brightness of the screen.</p>
 + 	<p>Increase screen brightness This key combination increases the brightness of the screen.</p>
 + 	<p>Decrease volume This key combination reduces the volume of the internal loudspeakers.</p>
 + 	<p>Increase volume This key combination increases the volume of the internal loudspeakers.</p>

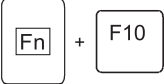
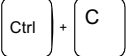
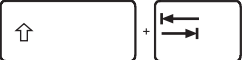
Combination	Description
	<p>Toggle output screen Use this key combination to select which screen(s) is/are used for display if an external monitor is connected.</p> <p>Screen output is possible:</p> <ul style="list-style-type: none"> • only on the notebook's LCD screen • only on the external monitor • on the notebook's LCD screen and the external monitor at the same time. <p>Press the key combination several times to switch through all possible settings.</p> <p>If you have connected two external monitors to the port replicator, the following display outputs are possible:</p> <ul style="list-style-type: none"> • only on the notebook's LCD screen • only on the external monitor (analogue) • at the same time on the LCD screen (digital) • at the same time on the notebook's LCD screen and on the external monitor (analogue) <p>You cannot use the key combination to switch output at the same time to both external monitors on the Port Replicator.</p>
	<p>Halt current operation This key combination can be used to halt an operation instantly without clearing the keyboard buffer.</p>
	<p>Back tab This key combination moves the cursor back to the previous tab stop.</p>

Tablet buttons

Your notebook has five multifunction tablet buttons. You can navigate on the screen with a simple press of a button, call preset applications or ones that you have set yourself.

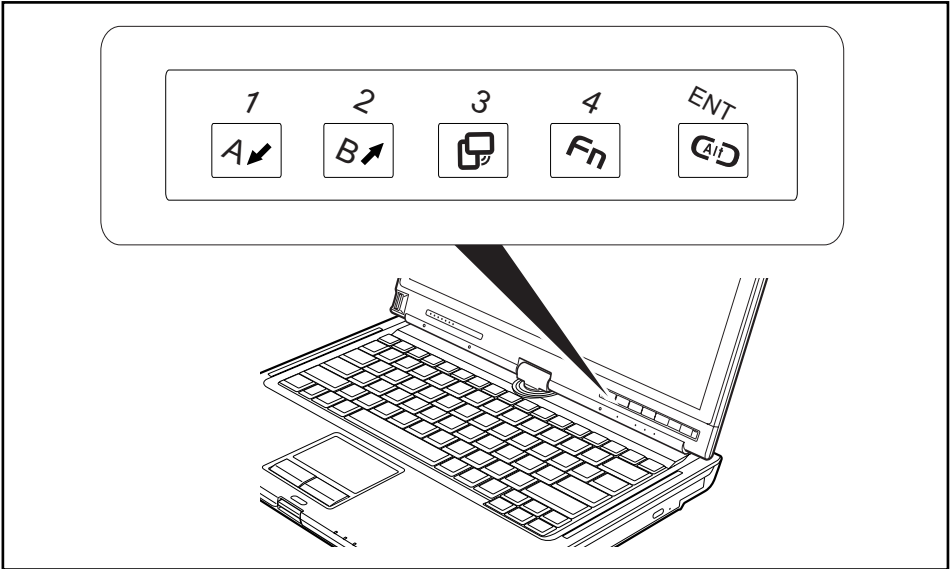





i

The tablet buttons have different uses in different modes.

You can also program each of them individually, see ["Programming the tablet buttons", Page 52.](#)



Basic functions when the device has booted



Button	Basic function
<p>1</p> 	<p>Scroll down</p> <p>You scroll down in your document with this key.</p>
<p>2</p> 	<p>Scroll up</p> <p>You scroll up in your document with this key.</p>

Button	Basic function
<p>3</p> 	<p>Change screen orientation</p> <p>When you press the Orientation button, the orientation of the screen display changes from portrait (vertical) to landscape (horizontal) or vice versa.</p> <p>When you would like to use the Tablet PC as an eBook, for example, you would use the portrait orientation.</p> <p>When accessing spreadsheets, you would more typically use a landscape orientation.</p>
<p>4</p> 	<p>Open Fujitsu menu</p> <p>Pressing this tablet button twice in quick succession will bring up the Fujitsu menu on your screen. The Fujitsu menu is used to change certain system settings.</p>
<p>ENT</p> 	<p>Log on to the system or open the Windows Task Manager</p> <p>If you hold this tablet button down for two seconds, you can log back on to the system again:</p> <ul style="list-style-type: none"> • after system startup • after a system lock • when returning from power management <p>After log-on, pressing the tablet button for two seconds launches the Windows Task Manager or – in the network – opens the security window.</p>

Functions when the security system is active

If you have assigned a supervisor password and/or user password, you can enter this via the tablet buttons when starting your device.

Button	Security functions
<p>1</p> 	<p>Security button 1 to enter the password.</p>
<p>2</p> 	<p>Security button 2 to enter the password.</p>
<p>3</p> 	<p>Security button 3 to enter the password.</p>



Button	Security functions
	Security button 4 to enter the password.
	Security button 1 to confirm the entered password.



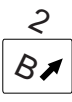

Detailed information on how to use the security functions is contained in Section ["Using the security function of the tablet keys", Page 95.](#)

Functions during Windows log-on

When the Windows log-on dialog is displayed, the tablet buttons provide special functions:

Button	Function
	Tab key.
	Enter key.
	<p>Change screen orientation</p> <p>When you press the Orientation button, the orientation of the screen display changes from portrait (vertical) to landscape (horizontal) or vice versa.</p> <p>When you would like to use the Tablet PC as an eBook, for example, you would use the portrait orientation.</p> <p>When accessing spreadsheets, you would more typically use a landscape orientation.</p>







Button	Function
 A square button with the number '4' above the 'Fn' logo.	<p> key, see "Key combinations", Page 51.</p>
 A square button with 'ENV' above a circle containing 'AiD'.	<p>Log on to the system or open the Windows Task Manager</p> <p>If you hold this tablet button down for two seconds, you can log back on to the system again:</p> <ul style="list-style-type: none">• after system startup• after a system lock• when returning from power management <p>After log-on, pressing the tablet button for two seconds launches the Windows Task Manager or – in the network – opens the security window.</p>

Key combinations

i

Key combinations cannot be changed.

You can find information on programming the tablet buttons in "[Programming the tablet buttons](#)", [Page 52](#).

Shortcut	Meaning
<p>4 7</p>  + 	<p>Starting predefined application A</p> <p>This button allows you to start a previously defined application.</p> <p>By default, the button is preconfigured to start the Launch Center application.</p>
<p>4 2</p>  + 	<p>Starting predefined application B</p> <p>This button allows you to start a previously defined application.</p> <p>By default, the button is preconfigured to start the Windows Journal application.</p>
<p>4 3</p>  + 	<p>Toggle output screen</p> <p>Use this key combination to select which screen(s) is/are used for display if an external monitor is connected.</p> <p>Screen output is possible:</p> <ul style="list-style-type: none"> • only on the notebook's LCD screen • only on the external monitor • both the LCD screen and the external monitor. <p>Press the key combination several times to switch through all possible settings.</p> <p>If you have connected two external monitors to the port replicator, the following display outputs are possible:</p> <ul style="list-style-type: none"> • only on the notebook's LCD screen • just the external monitor (analogue) • simultaneously on the LCD screen (digital) • both the LCD screen of the notebook and the external monitor (analogue) <p>You cannot switch output to both external monitors on the Port Replicator via the key combination.</p>

i

The tablet button **Fn** has a practical delay function: This allows you to press the two buttons for a shortcut one after the other instead of needing to press them both at the same time. After pressing the **Fn** tablet button, you have a short time (2 to 3 seconds) to press the second button.

Programming the tablet buttons

You can program the tablet buttons to open a specific application or execute a specific function when pressed.

Proceed as follows:

- ▶ In Control Panel, select the option to manage the settings for the tablet buttons and pen.
- ▶ Follow the instructions on the screen and program the tablet buttons as you require.

Webcam



Depending on the device variant, a WebCam may be integrated in your notebook.

Depending on the software used, you can use your Webcam to take pictures, record video clips or take part in web chats.

- The picture quality depends on the lighting conditions and the software being used.
- You can only operate the webcam with a particular application (e.g. an Internet telephony program or a video conferencing program which supports a webcam).
- When using the webcam the notebook support must not wobble.
- The webcam automatically adjusts itself to the current light level. For this reason the LCD screen may flicker while the light level is adjusted.



Further information on use of the webcam and additional settings can be found in the help function of the program which uses the webcam.

If you wish to carry out a function test with your webcam, you can use the corresponding test software available at "<http://ts.fujitsu.com/support/>".

Rechargeable battery

When not plugged into a mains socket, the notebook runs on its built-in battery. You can increase the life of the battery by caring for the battery properly. The average battery life is around 500 charge/discharge cycles.

You can extend the battery life by taking advantage of the available energy saving functions.

Charging, caring for and maintaining the battery

The notebook battery can only be charged, when the ambient temperature is between 5°C and max. 35°C.

You can charge the battery by connecting the notebook to the mains adapter (see "[Mains adapter connecting](#)", [Page 18](#)).

You can increase the life of your battery by allowing it to fully discharge before recharging it again. To do this, leave your notebook turned on while operated by the battery. Once the battery is running low, you will hear a warning alarm. If you do not connect the mains adapter within five minutes of the warning alarm described above sounding, your notebook will automatically switch off.

monitoring the battery charging level

Windows also has a "Battery status meter" in the taskbar for monitoring the battery capacity. When you place the mouse pointer on the battery symbol, the system displays the battery status.

The battery capacity can be monitored using an indicator which shows the current state of charge. Use the following menu to enable this feature:

Operating system	Menu
Windows XP	<i>Start – (Settings) – Control panel–Power options</i>
Windows Vista	<i>Start - (Settings) - Control panel - Hardware and Sound - Power options</i>
Windows 7	<i>Start – (Settings) – Control panel – Mobile PC – Power options</i>

The indicator is then displayed in the task bar as a battery symbol. When you place the mouse pointer on the battery symbol, the system displays the battery state of charge. Please refer to the Help facility of the operating system for more information.

Battery storage

Keep the battery pack between 0°C and +30°C. The lower the temperature at which the batteries are stored, the lower the rate of self-discharge.



If you will be storing batteries for a longer period (longer than two months), the battery charge level should be approx. 30 %. To prevent exhaustive discharge which would permanently damage the battery, check the level of charge of the battery at regular intervals.

To be able to make use of the optimal charging capacity of the batteries, the battery should be completely discharged and then fully recharged.



If you do not use the batteries for long periods, remove them from the notebook. Never store the batteries in the device.

Removing and installing the battery



Only use rechargeable batteries approved by Fujitsu Technology Solutions for your notebook.

Never use force when fitting or removing a battery.

Make sure that no foreign bodies get into the battery connections.

Never store a battery for longer periods in the discharged state. This can make it impossible to recharge.

Removing a battery

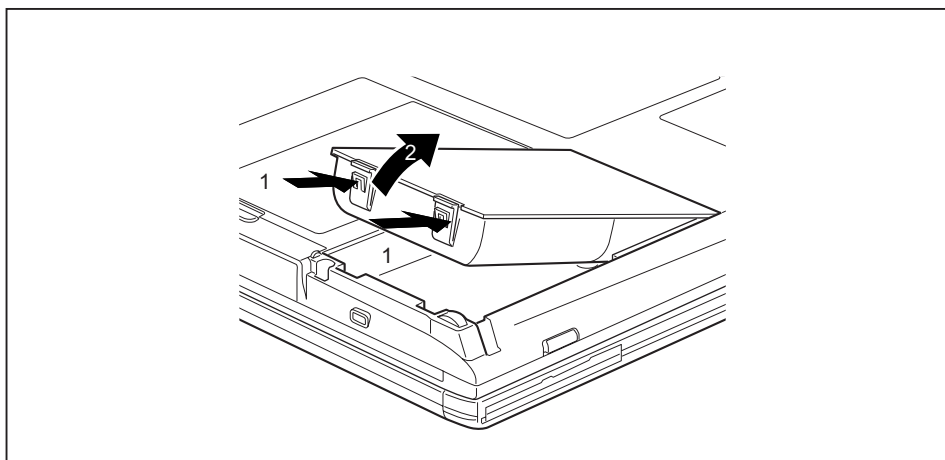

- ▶ Press in the two catches (1), keep them pressed and lift the battery out of the battery compartment (2).

Installing a battery

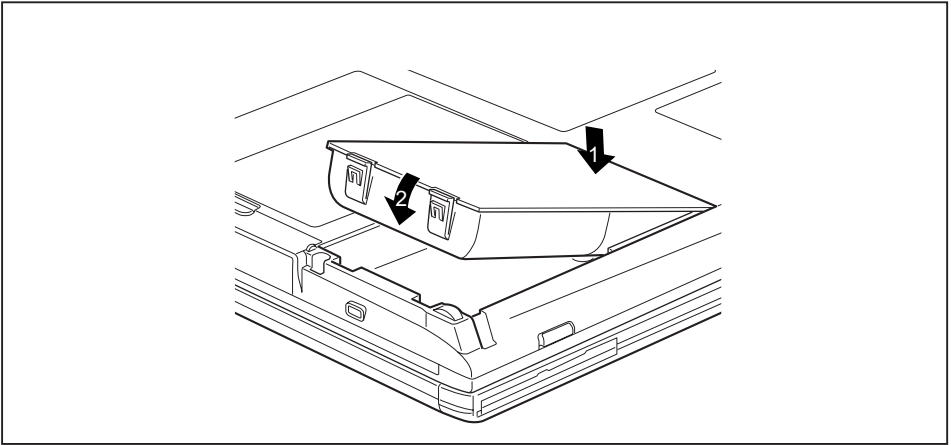

- ▶ Position the battery at the edge of the casing (1).
- ▶ Push the battery into the battery compartment until it locks into position (2).

Batteries with a capacity of 5800 mAh



With these batteries you can check the state of charge directly on the battery itself.

- ▶ Remove the battery (see ["Removing and installing the battery", Page 54](#)).

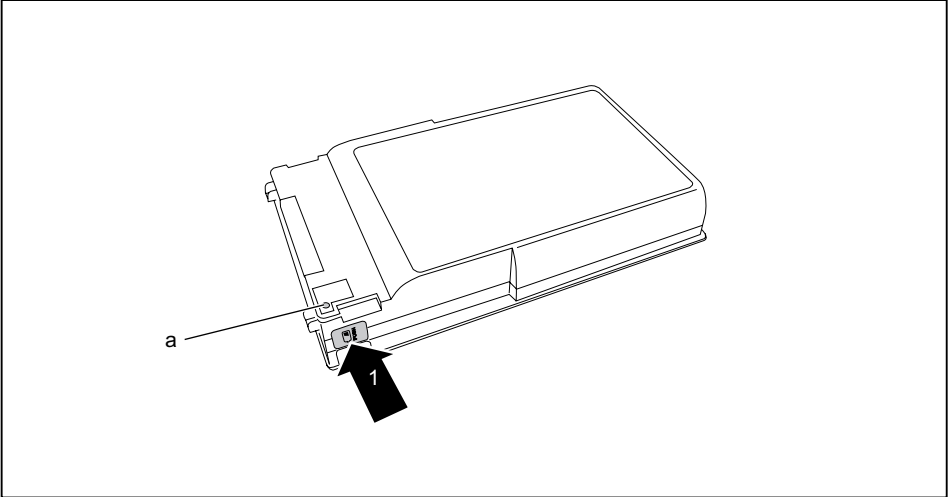

- ▶ Press the test key (1).
- ↳ The LED (a) lights up in one of the following colours:

LED indicator	State of charge
Green	The battery is between 50 % and 100 % charged.
Orange	The battery is between 13 % and 49 % charged.
Red	The battery is charged somewhere between 1 % and 12 %.
LED not lit	The battery is fully discharged.

Module

The design of your notebook enables the flexible use of notebook batteries and drives. The following modules can be operated in the module bay of your notebook:

- Second battery
- Second hard disk drive
- Optical drive
- Empty plug-in unit (save weight)



Only use modules designed for your notebook.

Do not use force when installing or removing the module.

Make sure that no foreign objects enter the module bay.



You can swap modules during operation. This means you do not need to switch off the notebook.

To replace a module, simply click on the corresponding icon in the task bar and then on *Exit* or *Select - Exit*.

The module can now be removed without any further actions being necessary.

Removing a module

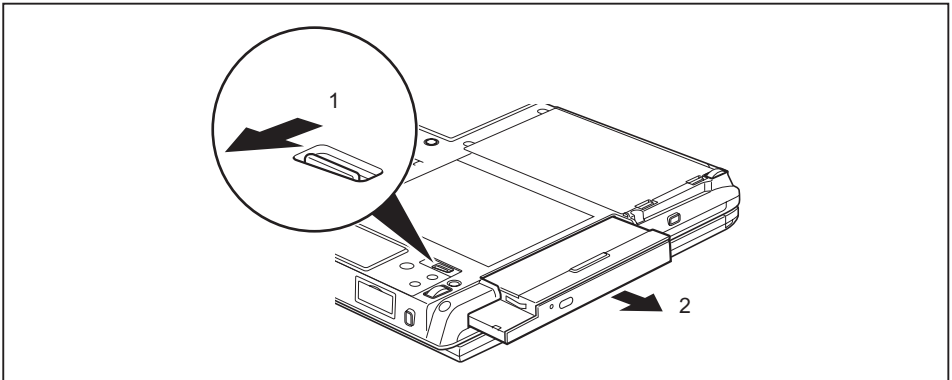

- ▶ Slide the release mechanism (1) in the direction of the arrow and hold.
- ▶ Now pull the module (2) out of the module bay.

Installing a module

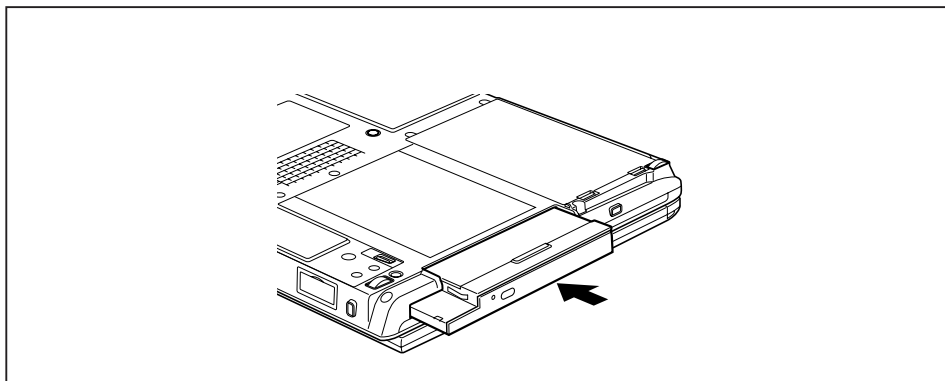

- ▶ Place the module into the module bay so that the contacts enter first.
- ▶ Push the module into the module bay until you feel it locking into place.

Optical drive



This product contains a light emitting diode, classified in accordance with IEC 8251:1993: LASER CLASS 1, and must therefore not be opened.

Handling data carriers

Observe the following guidelines when handling data carriers:

- Avoid touching the surface of a data carrier. Only handle data carriers by their edges.
- Always store data carriers in their cases. This will protect the data carrier against being covered in dust, scratched or damaged in any other way.
- Protect your data carriers against dust, mechanical vibrations and direct sunlight.
- Avoid storing a data carrier in areas subject to high temperatures or humidity.

You may use both 8-cm and 12-cm data carriers in the optical drive.

When using a data carrier of lesser quality, vibrations and reading errors may occur.

CD/DVD indicator

The CD/DVD indicator flashes when a data carrier is inserted. The indicator goes out when the drive is ready for reading. The indicator lights up when the drive is being accessed. You may only remove the data carrier when the indicator is unlit.



If the CD/DVD indicator does not go out after a data carrier has been inserted, but instead continues to flash, this means that the drive cannot access the data carrier.

Either the data carrier is damaged or dirty or you are using a data carrier that the drive cannot read.

Inserting or removing a data carrier

The notebook must be switched on.

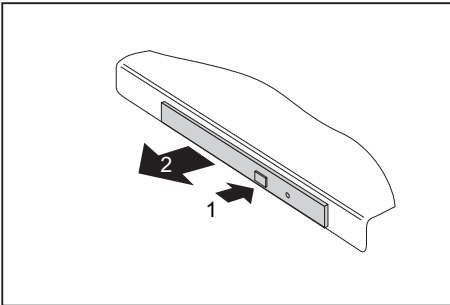

- ▶ Push the insert/eject button (1).
- ↳ The drive tray will open.
- ▶ Gently pull the drive tray (2) completely out.

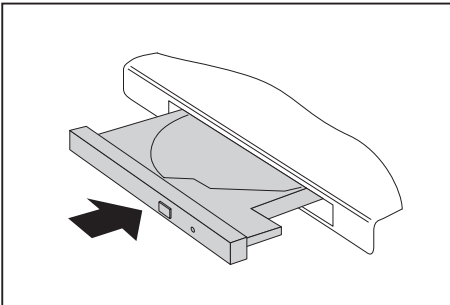

- ▶ Place the data carrier in the drive tray with the printed side facing upwards.

or

- ▶ Remove a data carrier that has been inserted.
- ▶ Push in the drive tray until you feel it lock into place.

Manual removal (emergency removal)

In the event of a power failure or damage to the drive, you can remove the data carrier manually.

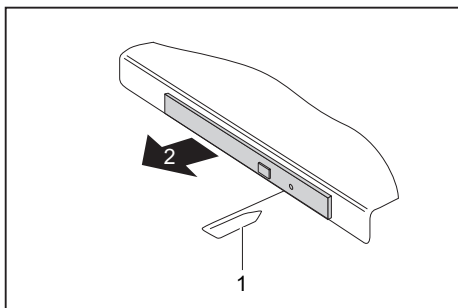

- ▶ Switch your notebook off.
- ▶ Push a pen or a piece of wire (such as a paperclip) firmly into the opening (1).
- ↳ The drive tray is ejected. You can now pull the drive tray (2) out of the drive.

Removing and replacing the casing cover (ventilation slot cover) to get rid of dust



To ensure optimum cooling of your notebook's components, you should clean the ventilation slots of the cooling fan after prolonged use.

This ensures optimum fan performance. Best cleaning results are achieved using a small hand-held vacuum cleaner.

If necessary, use a dry brush to remove dust from the ventilation slots.

Do not use any cleaning liquids! Ensure that liquid does not enter the device.

Be careful not to damage the ventilation fins. Do not use hard objects for cleaning.

To avoid the device overheating, do not remove the ventilation slot cover when the device is switched on.

- ▶ Prepare for removal, see chapter ["Preparing to remove components", Page 105](#).

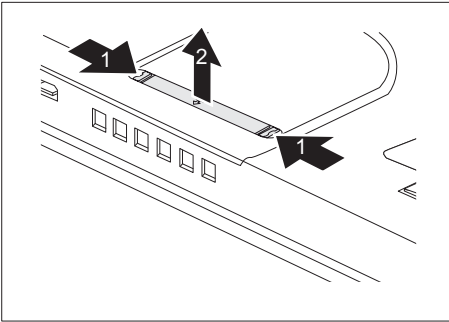

- ▶ Keep the locking tabs of the ventilation slot cover pressed down (1).
- ▶ Lift the ventilation slot cover out of the bay (2).
- ▶ Clean the dust chamber with a dry brush.

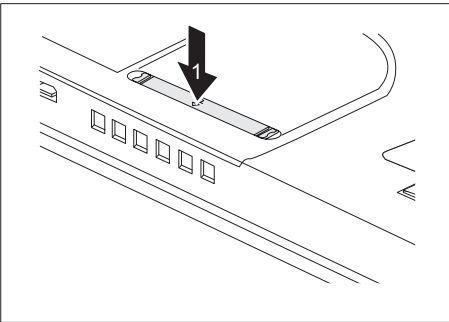

- ▶ Insert the ventilation slot cover into slot (1) and ensure that you feel it click into place.
- ▶ Complete the removal, see chapter ["Finishing component removal", Page 108](#).

Using the power-management features

The notebook uses less power when the available power-management features are used. You will then be able to work longer when using the battery before having to recharge it.



Power efficiency is increased and environmental pollution reduced. By choosing the best power options, you can make significant savings and at the same time help protect the environment.

When you fold down and close the LCD screen, depending on the setting in Windows, the notebook automatically enters a power saving mode.

We recommend the following settings:

Function	On external power	On battery power
Turn off monitor	After 10 minutes	After 5 minutes
Turn off hard disk(s)	After 15 minutes	After 10 minutes
Energy saving (S3)	After 20 minutes	After 15 minutes
Hibernate mode (S4)	After 1 hour	After 30 minutes

- ▶ Select the power management functions in your Control Panel.
- ▶ Select the Screen Saver in your Control Panel.

or

- ▶ Right-click on the desktop. Switch on the screen saver by clicking *Personalization – Change screen saver*.



If you need further information about an option, you can get help with most settings by pressing **F1** to open the Microsoft Help.

When the notebook is in power-saving mode, the following must be remembered:



During power saving mode, open files are held in the main memory or in a swap file on the hard disk.

Never turn off your notebook while it is in a power saving mode. If the built-in battery is nearly flat, close the open files and do not go into power saving mode.

If you do not intend to use your notebook for a long period of time:

- ▶ Exit power saving mode if necessary via the mouse or keyboard or by switching on the notebook.
- ▶ Close all opened programs and completely shut down the notebook.

Memory cards

Your notebook is equipped with an integrated memory card reader.



Observe the manufacturer's instructions when handling the memory cards.

Supported formats

It supports the following formats:

- Secure Digital (SD™ card)
- Memory Stick
- Memory Stick Pro

Inserting the memory card

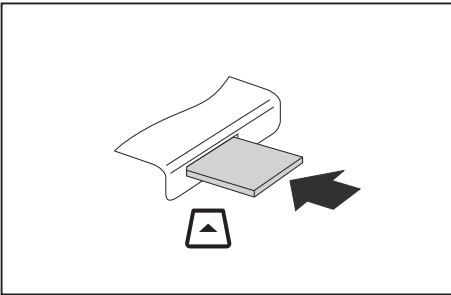

- ▶ Carefully slide the memory card into the slot. The label should be facing upward. Do not apply excessive force, as otherwise the delicate contact surfaces could be damaged.
- ↳ Depending on the particular type used, the memory card may protrude slightly from the slot.

Removing the memory card



In order to protect your data, always follow the correct procedure for removing the card outlined below.

You can stop the memory card via the corresponding icon in the task bar:

- ▶ Left-click on the icon.
- ▶ Select the card you want to stop and remove.
- ▶ Press the Enter key.
- ↳ Wait for the dialogue box which tells you that it is now safe to remove the memory card.

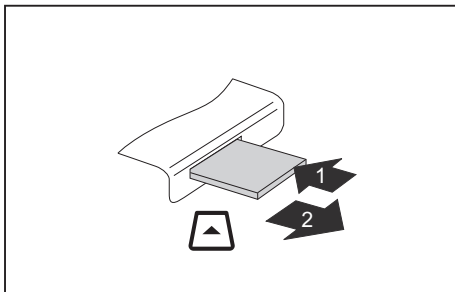

- ▶ On devices with card locking: Press on the storage card (1).
- ↳ The storage card is released and can now be removed.
- ▶ Pull the storage card out of the slot (2).

ExpressCards

An ExpressCard slot enables operation of an ExpressCard/34 or ExpressCard/54.



Consult the documentation supplied by the ExpressCard's manufacturer and follow the instructions provided.

Never use force when installing or removing an ExpressCard.

Make sure that no foreign objects enter the ExpressCard slot.

Inserting the card



Keep the placeholder for the slot in a safe place. When you remove the card again you must reinstall the placeholder. This prevents foreign bodies from getting into the slot.

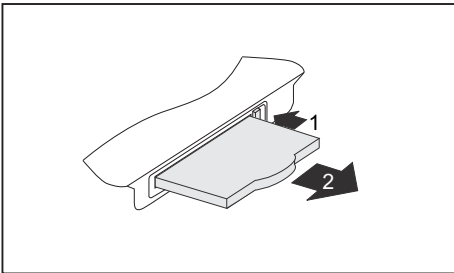

- ▶ If the eject button (1) is recessed, press it once so that it disengages. Now press the eject button again so that the placeholder protrudes slightly from the notebook.
- ▶ Pull the card placeholder out of the slot (2).

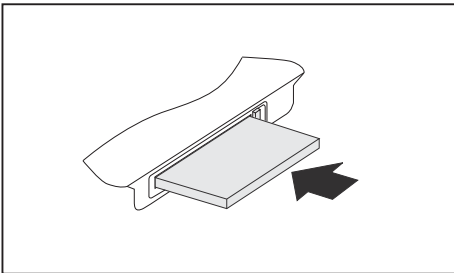

- ▶ Insert the card into the slot guide with the connection contacts first.
- ▶ Gently push the card into the slot either until it will go no further or you feel it engage. Do not use excessive force. Depending on the type, the card may protrude slightly from the slot.



Please see the documentation relating to the card for driver installation instructions.

Removing the card



Always remove the card according to the rules described below, to ensure that none of your data is lost.

You can stop the card using the corresponding icon in the task bar:

- ▶ Left click on the icon to safely remove hardware, located in the taskbar.
- ▶ Select the card you want to stop and remove.
- ▶ Press the "Enter" key.
- ↳ Wait for the dialog box which tells you that it is now safe to remove the card.

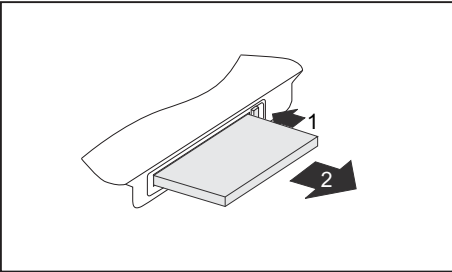

- ▶ If the eject button is lowered, you must first cause the eject button to release from the notebook casing. To do this, press the eject button until it pops out. Press the eject button (1) so that the card protrudes a little from the notebook.
- ▶ Pull the card out of the slot (2).

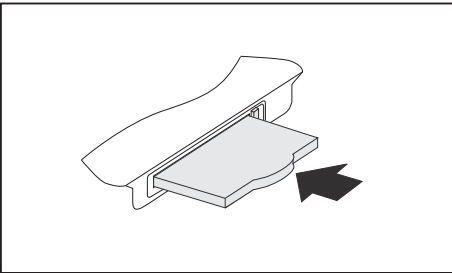

- ▶ Insert the card placeholder into the slot guide.
- ▶ Carefully slide the placeholder for the card as far as it will go into the slot. Do not use excessive force.

Loudspeakers and microphones

Information on the exact position of the speakers and microphone can be found in ["Ports and controls", Page 9](#).

Please refer to chapter ["Key combinations", Page 45](#) for information on setting the volume and also enabling/disabling the loudspeakers using key combinations.



If you attach an external microphone, the built-in microphone is disabled.

When you connect headphones or external speakers, the built-in speakers are disabled.

Information on connecting headphones and a microphone can be found in ["Connecting external devices", Page 98](#).

SIM card

A SIM Card (Subscriber Identity Module) is a chip card which is inserted in a mobile telephone or notebook and, together with an integrated UMTS module, enables access to a mobile radio network.



When handling SIM cards, follow the instructions supplied by the provider.

Inserting the SIM card

- ▶ Prepare for insertion of the SIM card, see chapter ["Preparing to remove components", Page 105](#).
- ▶ Open the protective rubber cover of the SIM card slot.



Do not pull on the SIM card lock! The lock could break off otherwise. Always slide the lock in the direction of the arrow as shown.

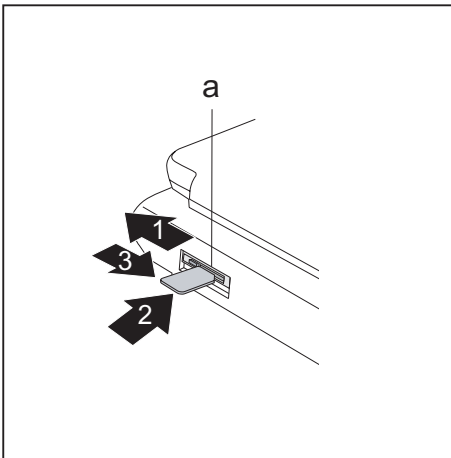

- ▶ Slide the SIM card lock (a) in the direction of the arrow (1).
The clip (a) controls the power supply for the UMTS module. The UMTS module is switched off while the clip is open.
- ▶ Slide the SIM card as shown into slot (2) until it engages.
- ▶ Slide the SIM card lock (a) in the direction of the arrow (3).

- ▶ Close the protective rubber cover of the SIM card slot.
- ▶ Complete the insertion process, see chapter ["Finishing component removal", Page 108](#).

Removing a SIM card

- ▶ Prepare for removal of the SIM card, see chapter ["Preparing to remove components", Page 105](#).
- ▶ Open the protective rubber cover of the SIM card slot.



Do not pull on the SIM card lock! The lock could break off otherwise. Always slide the lock in the direction of the arrow as shown.

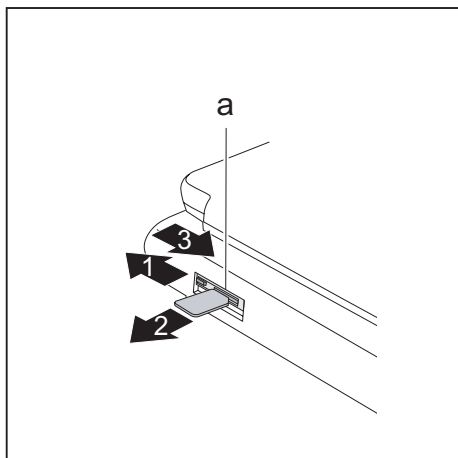

- ▶ Slide the SIM card lock (a) in the direction of the arrow (1).
- ▶ Press on the edge of the SIM card so that it pops out of the slot slightly.
- ▶ Pull the SIM card out of the slot in the direction of the arrow (2).
- ▶ Slide the SIM card lock (a) in the direction of the arrow (3).
- ▶ Close the protective rubber cover of the SIM card slot.

- ▶ Complete the removal, see chapter ["Finishing component removal", Page 108](#).

Optional wireless components Wireless LAN / BlueTooth / UMTS



The installation of radio components not approved by Fujitsu Technology Solutions will invalidate the certifications issued for this device.



Depending on the device configuration you ordered, your device will be equipped with Wireless LAN, Bluetooth and / or UMTS.

Switching the wireless components on and off



Before switching on your device for the first time, the on/off switch for radio components must be in the "ON" position.

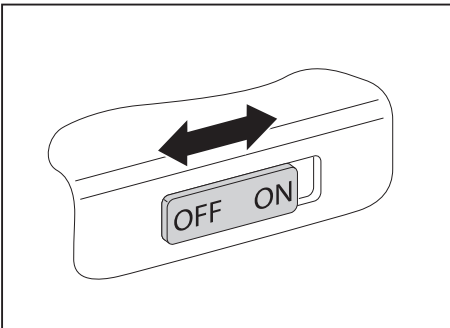

► Slide the ON/OFF switch into the "ON" position to activate the radio components.

or

► Slide the ON/OFF switch to the "OFF" position to deactivate the radio components.



If you switch off the radio components, the wireless LAN transmission unit (antenna) and, if present, the Bluetooth and UMTS module will also be switched off.

You can enable and disable the installed radio components individually using the *WirelessSelector* programme

You can also deactivate the wireless components individually in the *BIOS Setup*. For this to occur, you must either not have assigned a supervisor password or if a supervisor password has been assigned, you must know this password.

Pay attention to the additional safety notes for devices with wireless components provided in the "Safety" manual.

Details on using Wireless LAN can be found in the online help system included in the Wireless LAN software.

You can find more information on how to use Bluetooth on the CD you received with your Bluetooth software.

You can obtain more information on UMTS from your service provider.

Setting up WLAN access

- Requirement: A WLAN must be available and you must have the corresponding access information.



Information on configuring the WLAN access can be found in the documentation for your operating system.

Access via UMTS

If you ordered an integrated UMTS module with your system, you can enjoy optimum reception and maximum energy efficiency without awkward cables or antennas. The optional UMTS module is ready for use straight away.

If you did not order a UMTS module, you can purchase the accessories for UMTS reception from your retailer or your Fujitsu Technology Solutions dealer.

You will find information on establishing the connection with the UMTS network in the documentation for the hardware used.

You can connect your device with the Internet via UMTS. To do this, use one of the following types of connection:

- a USB dongle (a USB stick with your mobile phone provider's SIM card)
- UMTS ExpressCard (for inserting in the ExpressCard slot of your device)
- mobile end-device (e.g. mobile phone with Bluetooth or cable connection)

Ethernet and LAN

The internal network module of your notebook supports Ethernet LAN. You can use it to establish a connection to a local network (LAN = Local Area Network).

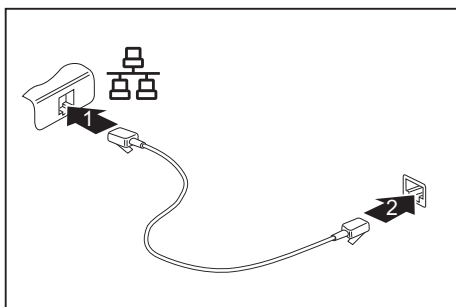

- ▶ Connect the network cable to the LAN port of the notebook (1).
- ▶ Connect the network cable to your network connection (2).



Your network administrator can help you to configure and use the LAN connections.

The network cable is not included in the delivery scope. This type of cable can be obtained from a specialist dealer.

Port replicator

The port replicator (available as an accessory) is a docking device using which you can quickly connect your notebook to your peripheral devices. For this purpose, the port replicator features standard ports for monitor, HDMI, LAN and USB devices.



Only use the supplied 100 W mains adapter from Fujitsu Technology Solutions to run the port replicator.

Additional information on the port replicator and on the various external devices that can be connected to it is contained in the chapter entitled "[Connecting external devices](#)", [Page 98](#).

Setting up the port replicator



Select a suitable location for the port replicator before setting it up. Follow the instructions below when doing so:

- Never place the port replicator on a soft surface (e.g. carpeting, upholstered furniture, bed). This can block the air vents of the notebook and cause overheating and damage.
- Place the port replicator on a stable, flat and non-slip surface. Please note that the port replicator's rubber feet may mark certain types of surface.
- Never place the port replicator and the mains adapter on a heat-sensitive surface.
- Do not expose the port replicator to extreme environmental conditions. Protect the port replicator from dust, humidity and heat.

Connect the notebook to the port replicator

- ▶ Disconnect the mains adapter cable from the DC socket (DC IN) of the notebook.

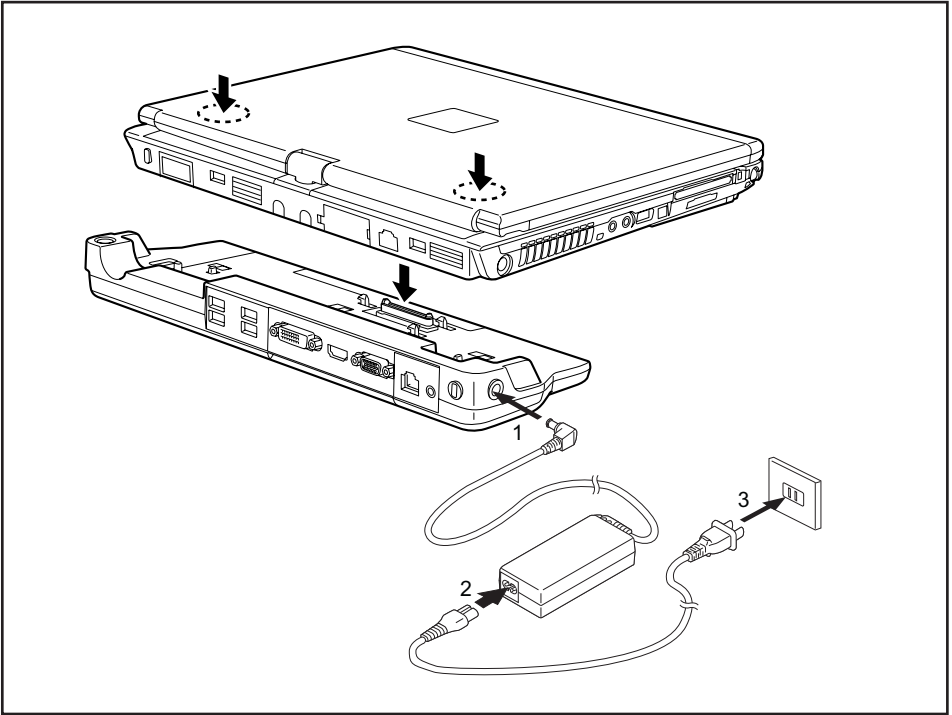

- ▶ Position the notebook on the port replicator in such a way that the docking connector on the underside of the notebook is aligned with the docking connector of the port replicator as shown.
- ▶ Press down on the notebook's rear corners so that it locks into position.
- ▶ Connect the mains adapter cable to the DC jack (DC IN) of the port replicator (1).
- ▶ Connect the power cable to the mains adapter (2).
- ▶ Plug the power cable into the mains socket (3).

Switching on the notebook via the port replicator

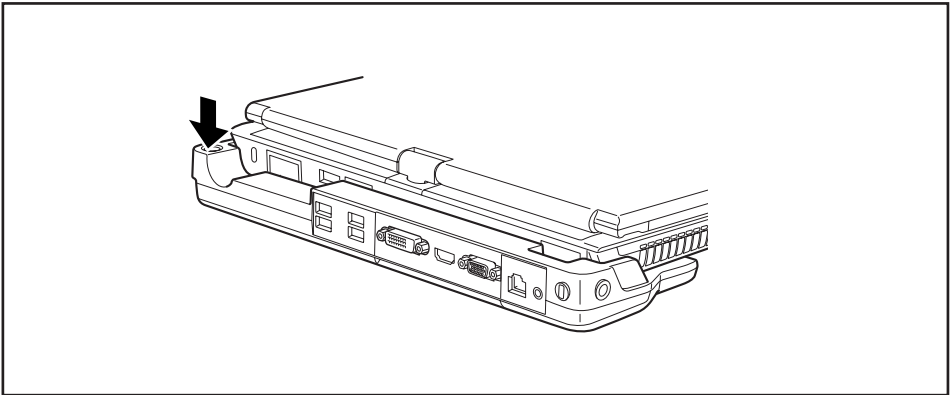

- ▶ Press the ON/OFF switch on the port replicator to switch the notebook on.

Switching off notebook via Port Replicator

- ▶ Close all applications and shut down your operating system (please refer to the manual for the operating system).



If the notebook cannot be shut down properly, press the ON/OFF button on the Port Replicator for approx. four seconds. The notebook will switch off. Any unsaved data may however be lost.

Disconnecting the notebook from the port replicator



Windows XP

Problems may occur if the notebook is removed from the port replicator during operation. We recommend that you switch off the notebook beforehand or use the Windows function Start – Undock.

Windows Vista / Windows 7

Problems may occur if the notebook is removed from the port replicator during operation. We recommend that you switch off the notebook beforehand or use the Windows function Start (arrow icon)



– Undock.

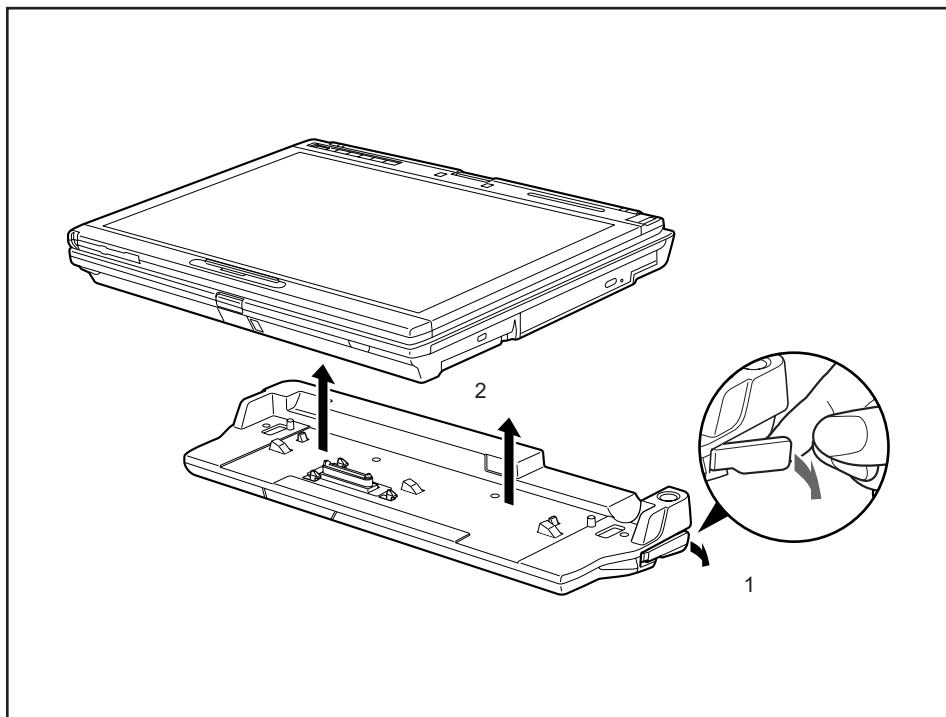

- ▶ Pull the release button in the direction of the arrow (1).
- ▶ Pick up the notebook (2).

Security functions

Your notebook has several security features that you can use to secure your system from unauthorised access.

This chapter explains how to use each function, and what the benefits are.



Please remember that in some cases, for example, forgetting your password, you may be locked out and unable to access your data. Therefore, please note the following information:

- Make regular backups to external storage devices such as external hard drives, CD or DVD disks.
- Some security functions need you to choose passwords. Make a note of the passwords and keep them in a safe place.

If you forget your passwords you will need to contact the our Service Desk. Deletion or resetting of passwords is not covered by your warranty and a charge will be made for assistance.

Brief overview of security functions



Detailed information about the security equipment of your device can be found in the "Professional Notebook" manual, on the "Drivers & Utilities" CD/DVD or on our website at ["http://ts.fujitsu.com/support/"](http://ts.fujitsu.com/support/).

Security functions	Type of protection	Preparation
Kensington Lock	Mechanical	Fit and lock Kensington MicroSaver (accessory).
Fingerprint sensor (depending on the device)	Biometric	Install the supplied fingerprint software.
BIOS password protection	Password protection for <i>BIOS Setup</i> , operating system and hard disk with supervisor and user password. The passwords consist of a maximum of eight alphanumeric characters.	Specify at least one supervisor password in the <i>BIOS Setup</i> and activate the password protection for the operating system and hard disk as desired.
Boot from removable media	Prevents unauthorised booting of an operating system from external media (e.g. USB stick, USB CD-ROM drive etc.).	In the BIOS Setup, go to the <i>Security</i> menu and edit the option <i>Boot from Removable Media</i> .
Owner Information	Overlay service desk or owner information during the boot process.	In the BIOS Setup, go to the <i>Security</i> menu and edit the option <i>Owner Information</i> .
System Lock	The BIOS and the system can only be started with SmartCard and PIN.	Initialise the SmartCard in the BIOS.
SmartCard reader (device dependent)	PIN and SmartCard protection for operating system	Install software e.g. <i>SmartCase Logon+</i> (accessories). Specify a password when using the <i>SmartCase Logon+</i> software.
Trusted Platform Module (device dependent)	Identification and authentication of the notebook	Define a supervisor password in the <i>BIOS Setup</i> and enable the TPM (<i>Security Chip</i>).

Configuring the fingerprint sensor

The fingerprint sensor can record an image of a fingerprint. With additional fingerprint software, this image can be processed and used instead of a password.

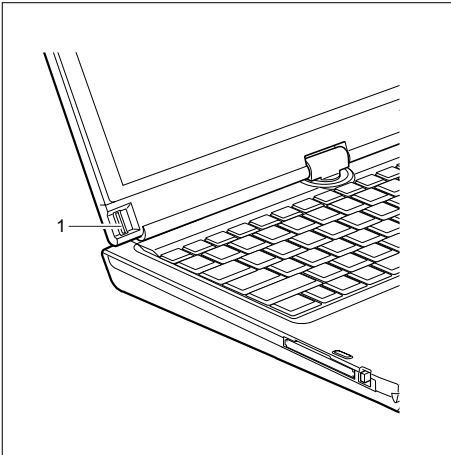

- ▶ You must install the fingerprint software in order to be able to use the fingerprint sensor (1).

Use Kensington Lock

Your device comes with a Kensington Lock device for the Kensington MicroSaver. With the Kensington MicroSaver, a sturdy steel cable, you can help protect your notebook from theft. The Kensington MicroSaver is available as an accessory.

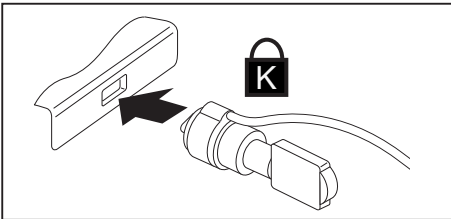

- ▶ Fit the Kensington MicroSaver on the device on your notebook.

Configuring password protection in BIOS Setup Utility



Before using the various options for password protection in the *BIOS Setup utility* to increase data security, please observe the following:

Make a note of the passwords and keep them in a safe place. If you forget your supervisor password you will not be able to access your notebook. Passwords are not covered by your warranty and a charge will be made for assistance.



Your password can be up to eight characters long and contain letters and numbers. No distinction is made between uppercase and lowercase.

Protecting BIOS Setup Utility (supervisor and user password)



If you have opened these operating instructions on the screen, we recommend that you print out the following instructions. Because you cannot call the instructions onto the screen while you are setting up the password.

You prevent unauthorised use of the *BIOS Setup Utility* with both the supervisor and the user password. The supervisor password gives you access to all functions of the *BIOS Setup Utility*, while the user password only provides some of the functions. You can only set a user password if a supervisor password has already been assigned.



Please refer to the "[Settings in BIOS Setup Utility](#)", [Page 109](#) section for a description of how to call up and operate the *BIOS Setup Utility*.

Setting supervisor and user password

- ▶ Start the *BIOS Setup Utility* and go to the *Security* menu.
- ▶ Select the *Set Supervisor Password* field and press the Enter key.
 - ↳ With *Enter new Password*: you are asked to enter a password.
- ▶ Enter the password and press the Enter key.
 - ↳ *Confirm new Password* requires you to confirm the password.
- ▶ Enter the password again and press the Enter key.
 - ↳ *Changes have been saved* is a confirmation that the new password has been saved.
- ▶ To set the user password, select *Set User Password* and proceed exactly as when configuring the supervisor password.
- ↳ If you do not want to change any other settings, you can exit *BIOS Setup Utility*.
- ▶ In the *Exit* menu, select the option *Save Changes & Exit*.
- ▶ Select *Yes* and press the Enter key.
- ↳ The notebook will be rebooted and the new password will come into effect. It will now be necessary to first enter your supervisor or user password in order to open the *BIOS Setup Utility*. Please note that the user password only provides access to a few of the BIOS settings.

Changing the supervisor or user password

You can only change the supervisor password when you have logged into the *BIOS Setup Utility* with the supervisor password.

- ▶ Call the *BIOS Setup Utility* and go to the *Security* menu.
- ▶ When changing the password, proceed exactly as for password assignment.

Removing passwords

To remove a password (without setting a new password) perform the following steps:

- ▶ Start the *BIOS Setup Utility* and go to the *Security* menu.
- ▶ Highlight the *Set Supervisor Password* or *Set User Password* field and press the Enter key.
 - ↳ You will be requested to enter the current password by the *Enter Current Password* prompt. You will be requested to enter a new password by the *Enter New Password* prompt.
- ▶ Press the Enter key twice.
- ▶ In the *Exit* menu, select the option *Save Changes & Exit*.
- ▶ Select *Yes* and press the Enter key.
- ↳ The notebook will now reboot with the password removed.
Removing the supervisor password simultaneously deactivates the user password.

Password protection for booting of the operating system



With the supervisor password you have set in the *BIOS Setup Utility* (see section ["Setting supervisor and user password", Page 78](#)), you can also prevent booting of the operating system.

Activating system protection

- ▶ Start the *BIOS Setup Utility* and go to the *Security* menu.
- ▶ Select the *Password on Boot* option and press the Enter key.
- ▶ Select the desired option (*Disabled*, *First Boot* or *Every Boot*) and press the Enter key
- ▶ Select the *Save Changes & Exit* option under *Exit*.
- ↳ The notebook will reboot. You will be prompted to enter your password (the supervisor password).

Deactivating system protection

- ▶ Start the *BIOS Setup Utility* and go to the *Security* menu.
- ▶ Select the *Password on Boot* option and press the Enter key.
- ▶ Select the *Disabled* option and press the Enter key.
- ↳ If you do not want to change any other settings, you can exit *BIOS Setup Utility*.
- ▶ Select the *Save Changes & Exit* option under *Exit*.
- ↳ The notebook will reboot. The system is no longer password-protected.

Password protection for the hard disk



The hard disk password prevents unauthorised access to the hard disk drives and is checked internally each time the system is booted. The condition for this is that you have assigned at least the supervisor password.

Activating hard disk protection

- ▶ Call up the *BIOS Setup* and select the *Security* menu.
- ↳ If you have not assigned BIOS passwords yet, define the supervisor and the user password now, if desired (see ["Security functions", Page 75](#)).
- ▶ Mark the *Hard Disk Security* field and press the Enter key.
- ▶ In the *Drive0* area mark the *Set Master Password* field and press the Enter key.
- ↳ *Enter new Password* then appears and you are asked to enter a password.
- ▶ Enter the password and press the Enter key.
- ↳ *Confirm new Password* requires you to confirm the password.
- ▶ Enter the password again and press the Enter key.
- ↳ *Setup Notice: Changes have been saved* is displayed to confirm that the new password has been saved.
- ▶ To assign the password for the second hard disk (*Drive1*), go to the *Drive1* area and select the field *Set Master Password*, then proceed in exactly the same way as for setting up the password for the first hard disk (*Drive0*).
- ↳ The field *Password Entry on Boot* is set to *Enabled* by default. You can exit the *BIOS Setup* once you have finished changing the settings.
- ▶ From the *Exit* menu, choose the option *Exit Saving Changes*.
- ▶ Press the Enter key and select *Yes*.
- ↳ The notebook reboots and your hard disk is now protected with a password. The system will ask you to enter the password when the notebook is restarted again.

Deactivating hard disk protection

To cancel a password without setting a new one, proceed as follows:

- ▶ Call up the *BIOS Setup* and select the *Security* menu.
- ▶ Mark the *Hard Disk Security* field and press the Enter key.
- ▶ In the *Drive0* area mark the *Set Master Password* field and press the Enter key.
- ↳ You will be initially requested to enter the old password by the *Enter current Password* prompt. You will then be requested to enter a new password by the *Enter new Password* prompt.
- ▶ After entering the password, press the Enter key three times.
- ▶ From the *Exit* menu, choose the option *Exit Saving Changes*.
- ▶ Press the Enter key and select *Yes*.
- ↳ The notebook reboots, and password protection for the hard disk is cancelled.
- ▶ To cancel the password for the second hard disk (*Drive1*), go to the *Drive1* area and select the field *Set Master Password*, then proceed in exactly the same way as for cancelling the password for the first hard disk (*Drive0*).

SmartCard reader

SmartCards are not supplied as standard equipment. You can use all SmartCards that comply with the ISO standard 7816-1, -2 or -3. These SmartCards are available from various manufacturers.

With the appropriate software you can use your SmartCard as an alternative to password protection, but also as a digital signature, for encrypting your e-mails or for home banking.

We recommend that you always use two SmartCards. Always keep one of the SmartCards in a safe place if you are carrying the other SmartCard with you.

In order to be able to take advantage of all the security features of your notebook, you will need a CardOS SmartCard from Fujitsu Technology Solutions.



The SmartCard can only be used with a PIN, offering maximum protection even if you lose the SmartCard. In order to maximise your security, the CardOS SmartCard is disabled if three incorrect attempts are made to enter the PIN.

When you use the CardOS SmartCard for the first time, you will either need to enter the preset PIN "12345678" or the PIN given to you by your systems administrator.

Inserting the SmartCard



Do not use force when inserting and removing the SmartCard.

Make sure that foreign objects do not fall into the SmartCard reader.

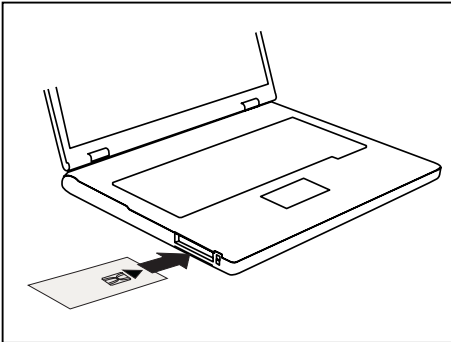

- ▶ Slide the SmartCard into the SmartCard reader with the chip facing upwards (on some variants it faces down) and to the front.

SmartCard as software protection (SmartCase™ Logon+)

Together with a CardOS SmartCard, software like SmartCase™ Logon+ gives you the option of logging on with the SmartCard and entering your PIN. If the PIN is entered correctly, SmartCard is checked and the operating system is booted. The SmartCard must remain in the SmartCard reader during the entire work session.

In addition, the software allows you to block your computer during breaks. This allows you to leave your notebook unattended, without the risk of unauthorised persons being able to access your opened documents and data.



The settings for blocking access to the computer during a session are set up in SmartCase™ Logon+ under *OS Logon (Smarty)*. Among other things, Smarty allows you to specify how users should log on to the operating system, e.g.:

- Fingerprint (without a SmartCard)
- TPM with PIN (without a SmartCard)
- Windows password
- SmartCard with PIN, with fingerprint or with PIN and fingerprint

To install, configure and use SmartCase™ Logon+, please refer to the documentation and online help on the CD with the SmartCase™ Logon+ software.

Proceed as follows to block your computer when you want to take a break:

- ▶ Pull the SmartCard out of the notebook during your work session.
- ↳ A window appears stating that the system is locked.
- ▶ When you want to continue with your work, insert the SmartCard and enter your PIN.
- ↳ You will automatically return to your opened documents.

SmartCard SystemLock (optional)

With *SystemLock* enabled, the device can only be started using an initialised SmartCard (SICRYPT, CardOS or Fujitsu) and a personal identification number (PIN). The SmartCard and PIN are checked during system booting in the BIOS, i.e. before the operating system is started.

SmartCard SystemLock		
SmartCard SystemLock	Not Installed	Item Specific Help
Install Single PC:	[Enter]	Installs the security for this PC, and creates a new SystemLock Admin SmartCard dedicated to this PC.
Install Group PC:	[Enter]	
		SmartCard data will be overwritten.
		A correct SmartCard is required for a permanent installation



All new SmartCards have a preset PIN (Personal Identification Number) and PUK (Personal Unblocking Key).

On SICRYPT and CardOS SmartCards, the value *12345678* is preset for the PIN and the PUK.

On Fujitsu cards, the value *0000* is preset for the PIN and the value *administrator* is preset for the PUK. For security reasons, we recommend that you change both PIN and PUK without fail.

Additional software (e.g. Smarty) is required so that the system can also check that the correct SmartCard is inserted while the system is running.



You will find information on how to uninstall *SystemLock* under "Uninstalling SystemLock". A system which was protected using *SystemLock* can no longer be released.

Always create a backup copy of the SmartCard which was used.

Access rights of SmartCards

A new SmartCard initially only has a preset PIN and PUK. Access rights and the customised PIN and PUK are not assigned until the SmartCard is initialised. The SmartCard type depends on the access rights assigned to the card, as described below:

- User SmartCard: starting the system, changing the PIN
- SuperUser SmartCard: starting the system, changes in *BIOS Setup*, changing the PIN
- Service SmartCard: changes in *BIOS-Setup*, cannot start the operating system
- Admin SmartCard: starting the system, changes in *BIOS Setup*, changing the PIN, uninstalling *SystemLock*, initialising SmartCards, blocking SmartCards

The following table shows an overview of the rights granted with each type of SmartCard when a PIN or PUK is entered:

	User SmartCard		SuperUser SmartCard		Service SmartCard		Admin SmartCard	
	PIN	PUK	PIN	PUK	PIN	PUK	PIN	PUK
Start-up system	x		x				x	
Run BIOS Setup			x		x		x	
Change own PIN	x		x		x		x	x
Unblocking own blocked SmartCard		x*		x*		x*		x
Unblock all blocked SmartCards								x
Generating user cards								x
Uninstall SystemLock								x

* *BIOS Setup* setting (*Unblock own SmartCard*)

Usually there is always one Admin SmartCard and at least one User or SuperUser SmartCard that will allow a system to be operated.

SmartCard user groups

User groups can be set up using *SystemLock*. This enables several systems to be started with one SmartCard. A user group consists of at least two systems. Each user that is allowed to start the systems is provided with one SmartCard. The user can start any of the systems using this SmartCard.

Basic information on setting up user groups

When installing *SystemLock*, the first PC in the user group is set up as a "Single PC". The Admin SmartCard generated during this process is used to set up the user group. *SystemLock* sets up each additional device as a "Group PC" during installation. The existing Admin SmartCard is inserted, information is read in and the device is added to the user group. The Admin SmartCard determines which user group the device belongs to.

If you use FSC-CardOS SmartCards, *SystemLock* can be administered via the Windows program "SystemLock Admin". "SystemLock Admin" allows you to conveniently manage *SystemLock* at the operating system level, create SystemLock Organisation Units and Groups, generate SmartCards for these Organisation Units or Groups, assign access rights for user cards at various levels and restore access rights using remote access. You can also change the SmartCard's PIN or PUK for yourself and other users and reactivate blocked cards. For a detailed description, see the "SystemLock Admin" Help manual.

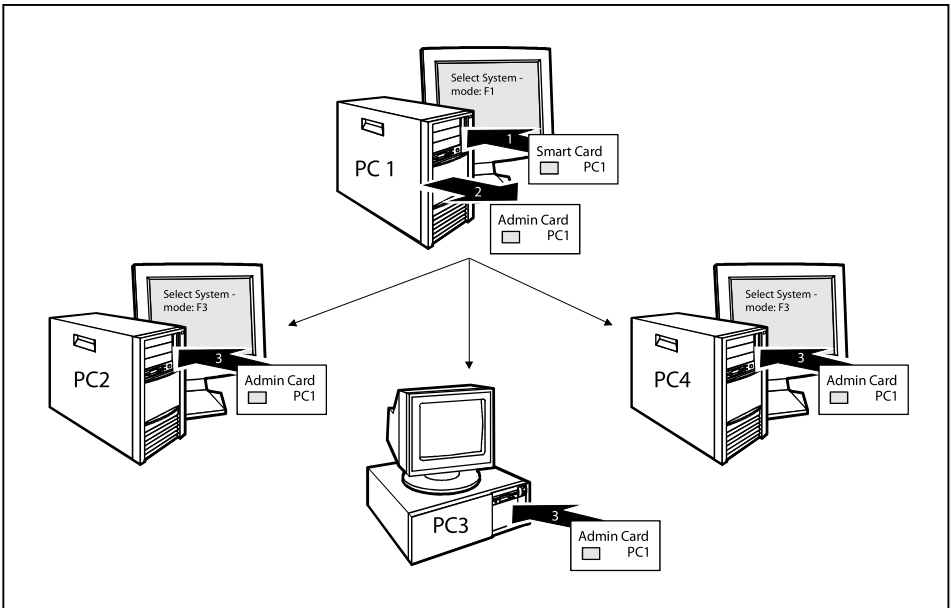

User SmartCards or SuperUser SmartCards must still be generated using *SystemLock* so that users can access the systems within the user group. Using a User SmartCard or SuperUser SmartCard a user can log on to each system within the user group.

Installing SystemLock

During initial installation, the first SmartCard becomes the Admin SmartCard. Together with the PUK, it has all access rights, and should therefore be kept in a safe place. It must only be used by an authorised user (Administrator), for instance to initialise user cards.

You need an Admin SmartCard if you want to set up a user group. You use this Admin SmartCard to add further systems to the user group.

Setting up the first system in a user group or a stand-alone system for use with SystemLock

- ▶ Start the device and call up BIOS Setup.
- ▶ From the *Security* menu, choose the option *SmartCard SystemLock*.
- ↳ The following SmartCard SystemLock menu will be displayed:

Security		
SmartCard SystemLock		Item Specific Help
SmartCard SystemLock	Not Installed	Installs the security from a SystemLock Admin SmartCard into this PC without modifying any data on the SmartCard.
Install Single PC	[Enter]	
Install Group PC	[Enter]	
<div style="border: 1px solid black; padding: 5px; display: inline-block;"> Enter PIN: [] </div>		rect SmartCard is red for a permanent installation.

- ▶ Insert a new SmartCard in the reader and press Enter.

 i

New SmartCards have a preset PUK (see above).

if you want to re-initialise a previously initialised SmartCard, you will need to know the PUK which was assigned to it.

▶ Enter the PUK.

↳ When the following appears:

- *ACCESS DENIED* = You have entered an invalid PUK. After six failed attempts, the SmartCard will be blocked and can no longer be used.

▶ Enter a new PIN at the following prompt:

↳ *Enter new PIN:*

Confirm new PIN:

 i

A number with 4 to 8 digits is acceptable for the new PUK. For security reasons, we recommend that you change the PUK for every SmartCard, and use an 8-digit number each time.

▶ Re-enter the new PIN to confirm.

↳ When the following appears:

- *PIN/PUK do not match* = You have confirmed the PIN incorrectly. You will be requested to re-enter the new PIN and reconfirm.

Please wait a few seconds after confirming the new PIN: *SystemLock* is being installed.

The following message will be displayed if installation is successful:

Setup Notice
Changes have been saved
[Continue]

▶ Now press the Enter key. The SystemLock administration menu will be displayed:

Security		Item Specific Help
SmartCard SystemLock		
SmartCard SystemLock	Installed	<p>Allows to deactivate The smartcard security.</p> <p>ATTENTION: Always check the BIOS password settings after uninstalling SystemLock.</p> <p>NOTICE: Reinstalling a SinglePC implies re-initializing all of your smartcards</p>
Uninstall:	[Enter]	
BIOS Recovery:	[Allowed]	
SmartCard and Pin	[Always required]	
SmartCard Initialization		
Admin SmartCard	[Enter]	
SuperUser SmartCard:	[Enter]	
User SmartCard:	[Enter]	
Service SmartCard:	[Enter]	
SmartCard Configuration		
Change PIN:	[Enter]	
Change PUK:	[Enter]	
Unblock SmartCard:	[Enter]	

► For security reasons, the preset PUK should always be changed before removing the new SmartCard. To do this, under *SmartCard Configuration*, select the option *Change PUK*, press the Enter key and input the new PUK.

► First enter the preset PUK.

↳ *Enter the PUK:*

New SmartCards have a preset PUK (see above).

You will need to know the PUK assigned to the SmartCard if you want to re-initialise a previously initialised SmartCard.

► Enter the PUK.

↳ When the following appears:

- *ACCESS DENIED* = You have entered an invalid PUK. After six failed attempts, the SmartCard will be blocked and can no longer be used.

► Enter the new PUK as follows.

↳ *Enter new PUK:*

Confirm new PUK:



A number with 4 to 8 digits is acceptable for the new PUK. For security reasons, we recommend that you change the PUK for every SmartCard, and use an 8-digit number each time.

► Re-enter the new PUK to confirm.

↳ When the following appears:

- *PIN/PUK do not match* = You have confirmed the PUK incorrectly. You will then be requested to re-enter and reconfirm the new PUK.

Instructions on how to initialise an additional SmartCard can be found in Section "[Carrying out administrator functions](#)", Page 91.

► If you do not want to initialise any further SmartCards, press **[Esc]** and remove the Admin SmartCard. NEVER write the PIN or PUK on the SmartCard under any circumstances!



Keep the SmartCard and PIN/PUK in a safe place and protect them from unauthorised access.

Adding a system to a user group

- ▶ Start the device.
- ▶ Call up *BIOS Setup* and select the *SmartCard SystemLock* page from the *Security* menu.
- ↳ The following SmartCard SystemLock menu will be displayed:

Security		
SmartCard SystemLock		Item Specific Help
SmartCard SystemLock	Not Installed	Installs the security from a SystemLock Admin SmartCard into this PC without modifying any data on the SmartCard.
Install Single PC	[Enter]	
Install Group PC	[Enter]	
Enter PIN: []		rect SmartCard is red for a permanent installation.

- ▶ Insert the Admin SmartCard for the user group.
 - ↳ *Enter PIN:*
 - ▶ Enter the PIN.
 - ↳ When the following appears:
 - *ACCESS DENIED* = You have confirmed the PIN incorrectly. You are then requested to enter and confirm the new PIN again. After three failed attempts, the SmartCard will be blocked and can then only be activated again by entering the PUK.
- Enter the PUK:*

► Enter the PUK.

↳ When the following appears:

- *ACCESS DENIED* = You have entered an invalid PUK. After six failed attempts, the SmartCard will be blocked and can no longer be used.

Please wait a few seconds after entering the PIN and PUK: *SystemLock* is being installed.

The following message will be displayed if installation is successful:

Setup Notice
Changes have been saved
[Continue]

Now press the Enter key. The SystemLock administration menu will be displayed:

Security		
SmartCard SystemLock		Item Specific Help
SmartCard SystemLock	Installed	Allows to deactivate The smartcard security.
Uninstall:	[Enter]	
BIOS Recovery:	[Allowed]	
SmartCard and Pin	[Always required]	ATTENTION: Always check the BIOS password settings after uninstalling SystemLock.
SmartCard Initialization		
Admin SmartCard	[Enter]	
SuperUser SmartCard:	[Enter]	
User SmartCard:	[Enter]	
Service SmartCard:	[Enter]	NOTICE: Reinstalling a SinglePC implies re-initializing all of your smartcards
SmartCard Configuration		
Change PIN:	[Enter]	
Change PUK:	[Enter]	
Unblock SmartCard:	[Enter]	

Generate a user card for the device as described in Section ["Carrying out administrator functions", Page 91](#).

► If you do not want to initialise any further SmartCards, press Esc and remove the Admin SmartCard.

Carrying out administrator functions

If you have an internal SmartCard reader, you can switch on the device by inserting the SmartCard. If you switch on the device with the On/Off switch then the following message appears:

SystemLock

Insert a SmartCard.

▶ Insert the Admin SmartCard. The following message will be displayed:

↳ *Enter your PIN:*

You can now select:

F2=Setup, F3=Change PIN, F4=Administration

▶ Press the **F4** function key. The following message will be displayed:

↳ *Enter the PUK:*

▶ If you have entered the PUK correctly, you receive the following message:

↳ *PUK OK.*

Initialize another SmartCard or press ESC to abort?

F5=User, F6=SuperUser, F7=Admin, F8=Service, F9=Unblock SmartCard, F10=Uninstall

F5: Normal User SmartCard ("System" access rights):

Only allows system start-up, does not allow changes in BIOS Setup.

F6: Extended User SmartCard ("System and Setup" access rights):

Allows system start-up and changes in BIOS Setup.

F7: Admin SmartCard ("Admin" access rights):

Allows generation of further Admin SmartCards.

F8: Service SmartCard ("Service" access rights):

Only allows changes in BIOS Setup.

F9: Re-activate a blocked User SmartCard.

Enables a new user PIN entry.

F10: Uninstalls SystemLock.

Additional SmartCards should be produced either as Normal User SmartCards ("System") or as Extended User SmartCards ("System and Setup"). These then have restricted access to the device.

▶ Press the desired function key. The following message will be displayed:

↳ *Remove the SmartCard.*

▶ Remove the Admin SmartCard.

↳ *Insert a SmartCard.*



Keep the Admin SmartCard in a safe place and protect it from unauthorised access.

▶ Insert the next SmartCard. It will be initialised as required.

↳ The following message will be displayed:

Remove the SmartCard.



Always change the PIN and PUK for all further SmartCards. The PUK is used to re-activate a blocked SmartCard.

▶ Remove the User SmartCard and label it, e.g. with the name of the user. But NEVER write the PIN on the SmartCard under any circumstances!

Remote Access Enabling – F4

Requirement:

The device is centrally administered as part of an Organisation Unit and is registered in a SystemLock Admin database. The SmartCard used for the group installation must have been initialised beforehand using the *SystemLock Admin.EXE* Windows program (see "[SmartCard user groups](#)", Page 85).

In order to enable remote access to a device for a user, or to grant one-time remote access to the device for a guest or service technician, proceed as follows:

- ▶ Start the device.
- ↳ The prompt to insert a SmartCard will appear.
- ▶ Press the F4 key.

SmartCard SystemLock	
Org Unit:	Company Department 1
PC Group:	Group 1
I-CODE 1:	0123456789ABCDEF
I-CODE 2:	0123456789ABCDEF

The following dialogue box will appear:

- ↳ The user must then contact the administrator or the administration hotline and inform them of the data and codes displayed .

The administrator then specifies the type of the once-only access rights:

<i>User access</i>	The user can boot the system once.
<i>Service access</i>	The user has one-time access to the BIOS for service purposes, without access to the SystemLock functions.
<i>Admin access</i>	The user has access to the BIOS and the SystemLock functions, e.g. for activating the device when the associated SmartCard has been lost.

An activation code will be generated that depends on the access rights granted; this will be given to the user by the Hotline.

The user must now press the Enter key on the PC to be activated, enter the first half (code 1) of the activation code and confirm the entry by pressing Enter. The dialogue box for entering the second half (code 2) of the activation code will appear. There is no limit to the number of incorrect entries that can be made.

When all 32 characters of the activation code have been correctly entered, the device will boot with the rights assigned by the administrator, in the same way as if a corresponding SmartCard were inserted.



The activation code can only be used once to start the device; it immediately becomes invalid when the device boots. If you wish to switch off the device and start it again without your SmartCard, the procedure described above must be repeated each time.

Switch on the device using SystemLock

If you have an internal SmartCard reader, you can switch on the device by inserting the SmartCard. If you switch on the device with the On/Off switch then the following message appears:

Insert a SmartCard.

- ▶ Insert your SmartCard.
- ↳ *Enter PIN:*
- ▶ Enter your PIN.
- ↳ When the following appears:
 - *ACCESS DENIED* = You have entered an incorrect PIN. After three failed attempts, the SmartCard will be blocked and can only be enabled again by entering the PUK.
- ↳ Depending on the rights assigned to your SmartCard, you can select the following functions when this message is displayed on the screen:

F2=Setup, F3=Change PIN

If your SmartCard has the appropriate rights, you can:

F2: start BIOS Setup.

F3: change PIN.

If you do not select a function, the system will boot up.

Start BIOS Setup F2

A SmartCard with the appropriate rights must be inserted (SuperUser, Service or Admin).

Changing PIN

It is possible to change the PIN for any initialised SmartCard.

- ▶ Press the function key F3.
- ▶ Enter the old PIN.
- ▶ Enter the new PIN.



A number with 4 to 8-digits is acceptable for the new PIN. For security reasons, we recommend that you change the PIN for every SmartCard, and use an 8-digit number each time.

- ▶ Confirm the new PIN.

Uninstall SystemLock

- ▶ Start the device.
- ▶ Follow the instructions given in section "[Carrying out administrator functions](#)", [Page 91](#). Select "Uninstall" to uninstall *SystemLock*. You can now use the device again without the need for a SmartCard.

Error messages

In this chapter you will find the error messages which are generated by the mainboard and the SmartCard reader.

Error	Cause
<i>Boot access denied</i>	The SmartCard has no access rights to the system.
<i>Check your SmartCard</i>	The SmartCard is either inserted incorrectly or it is not a suitable SystemLock SmartCard.
<i>SmartCard reader FAILURE</i>	An error has occurred on the serial port to the SmartCard reader. If this error occurs frequently, the connection between the SmartCard reader and the mainboard must be checked, or the SmartCard reader must be replaced. While the error is present, access to the system is blocked.
<i>Non-authorized SmartCard</i>	The SmartCard cannot be used on this device. The SmartCard has been configured for a different device.
<i>SystemLock installation FAILED:</i>	An error occurred while installing <i>SystemLock</i> . Do not switch off the device, insert the "BIOS Flash diskette" instead. Perform a BIOS update and try the installation process again.
<i>The SmartCard is blocked. Enter the PUK:</i>	You have exceeded the maximum allowed number of incorrect PIN entries. The SmartCard is blocked. Enter the administrator PUK to re-activate the SmartCard. You must then enter a new User PIN to restart the system.

Using the security function of the tablet keys

If you have assigned a supervisor password and/or user password in the form of a combination of tablet button presses, as described below, you can enter this via the tablet buttons when starting your device.

Setting the Supervisor password

- ▶ Select Start - Run.
- ▶ Enter the following at the command line: C:\Program Files\Fujitsu\Security Panel Application\Supervisor\FJSECS.EXE.
- ▶ Confirm with .
- ▶ Follow the instructions on the screen.

Setting the User password

- ▶ Select Start - All Programs.
- ▶ Select Security Panel Application – Security Panel Application.
- ▶ Follow the instructions on the screen.

Entering passwords using the tablet buttons

The passwords to be entered via the tablet buttons are usually composed of a combination of button presses, e.g. button **2** + button **3** followed by button **1** and the **ENT** button.

- ▶ Enter your password using the buttons **1** to **4**.
- ▶ Confirm by pressing **ENT**.
- ↳ The device will be unlocked.

Trusted Platform Module (TPM) (device-dependent)

To use the TPM, you **must** activate the TPM in the *BIOS Setup* before the software is installed. The condition for this is that you have assigned at least the supervisor password (see ["Security functions", Page 75](#)).

Options for using the TPM

You can use the TPM in different ways:

SmartCase™ Logon+	SmartCase™ Logon+ offers additional help with managing and using the numerous passwords required to work with the computer. To install, configure and use SmartCase™ Logon+, please refer to the documentation and online help on the CD with the SmartCase™ Logon+ software.
Security API	Smart Security API 4.1 is middleware which supports the entire range of mobile and stationary clients from Fujitsu Technology Solutions. Independent of the TPM hardware, it is needed by everyone who uses a PKI Smart Security environment for identification purposes.
Microsoft® BitLocker	BitLocker Drive Encryption (BDE) is a feature of Microsoft® Vista Enterprise and Ultimate Editions for encryption of the hard disk drive. Here, BitLocker uses the TPM for the storage of the recovery data which are used for decryption of the partition. It is also possible to use BitLocker without TPM and only to use the USB dongle for storing the crypto key. This option is mainly of interest if Vista is installed on a computer on which TPM is not installed or an older version (before Version 1.2) is installed. For BitLocker to work, you must have set up at least two partitions on your hard drive. The first partition contains the boot information. The second, larger partition is encrypted and contains the operating system as well as the user data. Important: The partitions must be set up before Windows Vista is installed.

Enabling TPM

- Requirement: You have assigned a supervisor password, see ["Security functions", Page 75](#).
- ▶ Call up the BIOS Setup and select the *Security* menu.
- ▶ Mark the *TPM Security Chip Setting* field and press the Enter key.
- ▶ Select *Enabled* to activate the TPM.
- ↳ Once you have activated the TPM the *Clear Security Chip* option appears.
Select *Clear Security Chip* to delete the holder in the TPM. By clicking on *Enabled*, all secret keys (e.g. SRK - Storage Root Keys, AIK - Attestation Identity Keys etc.) generated by applications are deleted.
Please note that you will then no longer be able to access the data you have encrypted with the keys based on that holder.
- ▶ Select the *Exit Saving Changes* option in the Exit menu.
- ▶ Press the Enter key and select *Yes*.
- ↳ The notebook will restart, and TPM will be enabled after the reboot.

Disabling TPM

- Requirement: You have assigned a supervisor password, see ["Security functions", Page 75](#).
- ▶ Call up the BIOS Setup and select the *Security* menu.
- ▶ Mark the *TPM Security Chip Setting* field and press the Enter key.
- ▶ Select *Disabled* to deactivate the TPM.
- ▶ From the *Exit* menu, choose the option *Exit Saving Changes*.
- ▶ Press the Enter key and select *Yes*.
- ↳ Your notebook will now restart and TPM will be disabled.

Connecting external devices



Always refer to the safety information provided in ["Important notes", Page 13](#) before connecting or disconnecting any devices to or from your notebook.

Always read the documentation supplied with the device you wish to connect.

Never connect or disconnect cables during a thunderstorm.

Never pull at a cable when disconnecting it. Always grasp the plug.

Follow the steps below in order, when connecting or disconnecting devices to your notebook:



With some devices such as USB devices, it is not necessary to switch off the notebook and the device before connecting/disconnecting. For more information about whether or not devices need to be switched off, please refer to the documentation supplied with the external device.

Some of the external devices require special drivers (see the operating system and external device documentation).

Connecting devices to the notebook

1. Turn off your notebook and all external devices.
2. Unplug your notebook and all devices from the mains sockets.
3. Connect the cables for your external devices following the instructions.
4. Plug all power cables into the mains sockets.

Disconnecting devices from the notebook

1. Turn off your notebook and all external devices.
2. Unplug your notebook and all devices from the mains sockets.
3. Disconnect the cables for your external devices following the instructions.

Connecting an external monitor

i

The notebook itself does not have a DVI port. The optional Port Replicator available for your notebook provides this port.

An analogue monitor is connected to the analogue VGA monitor port, a digital monitor to the DVI monitor port. Screen output is limited to a maximum of two screens at any one time (see ["Key combinations", Page 45](#), section "Toggle output screen").

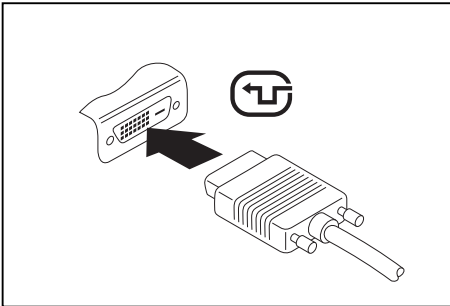

Digital DVI monitor port

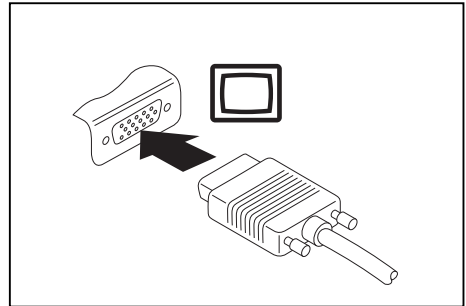

Analogue VGA monitor port

- ▶ Switch off the notebook and the external monitor.
- ▶ Plug the data cable of the external monitor into the monitor port.
- ▶ First switch on the external monitor and then the notebook.

i

You can also switch back and forth between the external monitor and the notebook's LCD monitor, see chapter ["Key combinations", Page 45](#).

You can display the same picture on the external monitor and the notebook LCD screen simultaneously.

HDMI port



The notebook itself does not have an HDMI port. The Port Replicator which is available as an option for your notebook offers you this type of port.

The HDMI port of your notebook can be used to connect an external amplifier, LCD TV or a plasma TV with an HDMI connection.

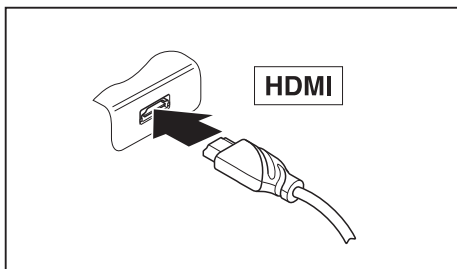

- ▶ Connect the data cable to the external device.
- ▶ Connect the data cable to the HDMI port of the notebook.



Some LCD televisions have only two loudspeaker connections and therefore cannot reproduce Dolby digital or DTS. In order to reproduce the sound, you must go into *Windows* and adjust the sound settings.

Proceed as follows:

- ▶ Select *Startsymbol – (Settings) – Control Panel – Hardware and Sound – Sound*.
- ▶ Mark *Realtek HDMI Output*.
- ▶ Select *Properties – Supported formats*.
- ▶ Deactivate the settings *DTS audio* and *Dolby digital*.
- ▶ Confirm the settings with *OK*.

Connecting USB devices

On the USB ports, you can connect external devices that also have a USB port (e.g. a DVD drive, a printer, a scanner or a modem).



USB devices are hot-pluggable. This means you can connect and disconnect devices while your operating system is running.

USB 1.x has a maximum data transfer rate of 12 Mbit/s.

USB 2.x has a data transfer rate of up to 480 Mbit/s.

Additional information can be found in the documentation for the USB devices.

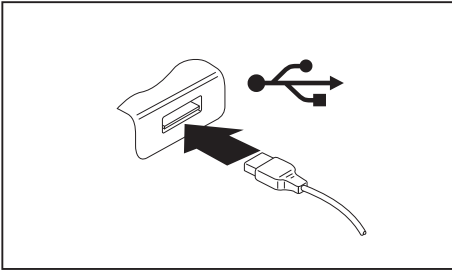

- ▶ Connect the data cable to the external device.
- ▶ Connect the data cable to a USB port of the notebook.



Device drivers

USB devices will be automatically recognised and installed by your operating system.

How to remove USB devices correctly



Always correctly remove the device according to the rules described below, to ensure that none of your data is lost.

- ▶ Left click on the icon to safely remove hardware, located in the taskbar.
- ▶ Select the device which you want to shut down and remove.
- ▶ Press the Enter key.
- ↳ Wait for the dialogue box which tells you that it is now safe to remove the device.

Connecting FireWire devices

External devices such as digital audio/video devices or other high-speed devices can be connected to the FireWire port. The FireWire port operates at a speed of up to 400 Mbit per second.



FireWire devices are hot-pluggable. Therefore, the cables of FireWire devices can be connected and disconnected with the system switched on. Additional information is provided in the documentation for the FireWire devices.

- ▶ Connect the data cable of the external devices to the FireWire port of the notebook.
- ▶ Plug the power cable of the external device into the mains socket.

Connecting external audio devices

Microphone port / Line In

The microphone port/Line In allows you to connect an external microphone, a MiniDisc player, MP3 player, CD player or a tape deck to your notebook.

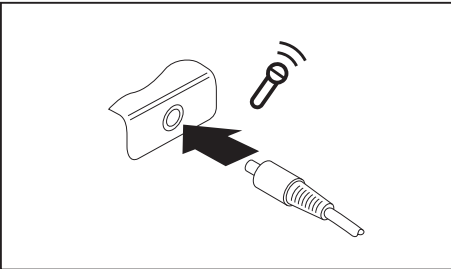

- ▶ Connect the audio cable to the external device.
- ▶ Connect the audio cable to the microphone port/Line In of the notebook.

Headphone port

You can connect headphones or external loudspeakers to your notebook via the headphone port.

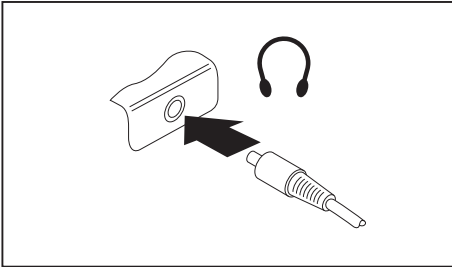

- ▶ Connect the audio cable to the external device.
- ▶ Connect the audio cable to the headphone port of the notebook.
- ↳ The internal loudspeakers are disabled.



If you purchase a cable from a retailer, please note the following information:

The headphone port on your notebook is a "3.5 mm jack socket".

If you want to connect headphones or a speaker you will need a "3.5 mm jack plug".

Removing and installing components during servicing



Only qualified technicians should repair your notebook. Unauthorised opening or incorrect repair may greatly endanger the user (electric shock, fire risk) and will invalidate your warranty.

After consulting the Hotline/Service Desk, you may remove and install the components described in this chapter yourself.



If you remove and install components without consulting the Hotline/Service Desk, then the warranty of your notebook will be voided.

Notes on installing and removing boards and components

- Switch the notebook off and pull the power plug out of the mains socket.
- Always remove the battery.
- Take care when you use the locking mechanisms on the battery and any other component.
- Never use sharp objects such as screwdrivers, scissors or knives as leverage to remove covers.



Boards with electrostatic sensitive devices (ESD) are marked with the label shown.

When handling boards fitted with ESDs, you must always observe the following points:

- You must always discharge static build up (e.g. by touching a grounded object) before working.
- The equipment and tools you use must be free of static charges.
- Remove the power plug from the mains supply before inserting or removing boards containing ESDs.
- Always hold boards with ESDs by their edges.
- Never touch pins or conductors on boards fitted with ESDs.

Preparing to remove components

If you are going to remove or change system components, prepare for the removal as follows:



Please observe the safety information in chapter ["Important notes", Page 13](#).
Remove the power plug from the mains outlet !

- ▶ Switch the device off.



The device must not be in energy-saving mode !

- ▶ Close the LCD screen.
- ▶ Remove all the cables from the device.
- ▶ Turn the device over and place it on a stable, flat and clean surface. If necessary, lay an anti-slip cloth on this surface to prevent the device from being scratched.
- ▶ Remove the battery (see ["Removing a battery", Page 54](#)).

Installing and removing memory expansion

If you are asked by the Hotline/Service Desk to remove and install the memory expansion yourself, proceed as follows:



Please observe the safety information in chapter ["Important notes", Page 13](#).

When installing/removing memory modules, the battery must be removed from the notebook and the notebook must not be connected to the power supply, see ["Preparing to remove components", Page 105](#).

Only use memory expansion modules that have been approved for your notebook (see ["Technical data", Page 120](#)).

Never use force when installing or removing a memory extension.

Make sure that foreign objects do not fall into the memory extension compartment.

You must open the service compartment to remove or install a memory module. On some devices, opening the compartment may expose other components. These components should be removed and replaced only by authorised specialists. Therefore, be sure to observe the following:



Individual components can become very hot during operation. Therefore, we recommend that you wait one hour after switching off the notebook before removing or installing memory modules. Otherwise, there is a risk of suffering burns!

As some components are exposed that are sensitive to static electricity, please take note of chapter ["Notes on installing and removing boards and components", Page 104](#).

Removing a cover

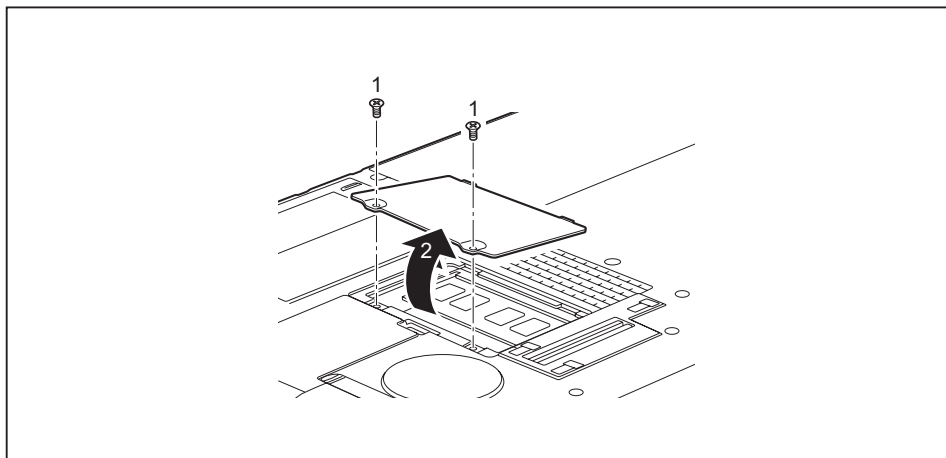

- ▶ Remove the screws (1).
- ▶ Pull off the cover from the notebook in the direction of the arrow (2).

Removing memory modules

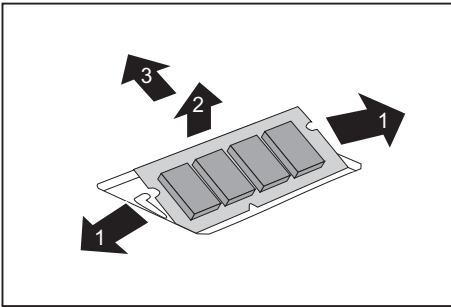

- ▶ Carefully push the two mounting clips outwards (1).
- ↳ The memory module snaps upwards (2).
- ▶ Pull the memory module out of its slot in the direction of the arrow (3).

Installing a memory module

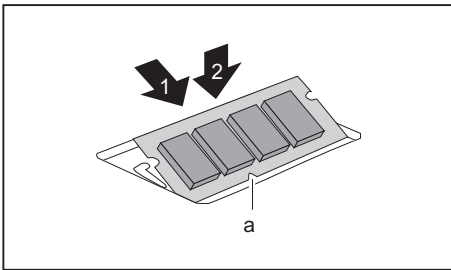

- ▶ Insert the memory module with the contacts and the recess (a) facing the slot (1).
- ▶ Carefully push the memory module downwards until you feel it click into place (2).

Attaching the cover

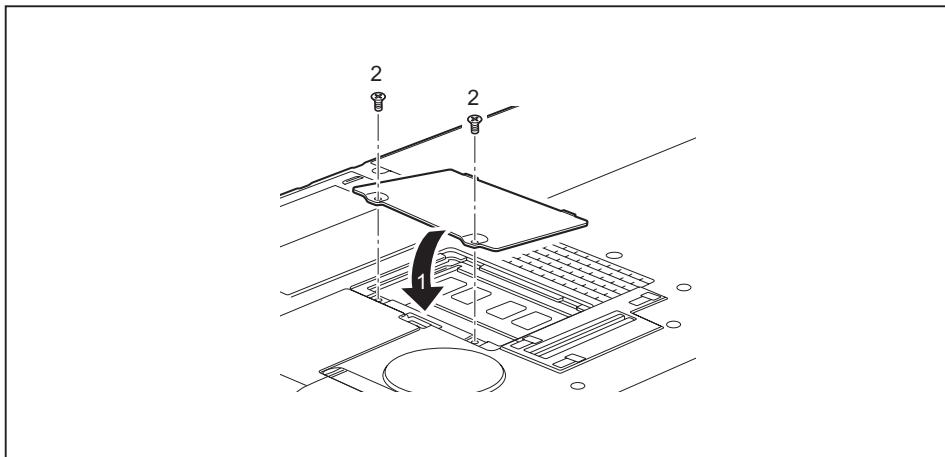

- ▶ Place the cover into position, following the direction of the arrow (1).
- ▶ Secure the cover with the screws (2).
- ▶ Install the battery again (see ["Removing and installing the battery", Page 54](#)).
- ▶ Turn the notebook the right way up again and place it on a flat surface.
- ▶ Reconnect the cables that were previously disconnected.

Finishing component removal

After you have removed or changed the system components as you required, please prepare your device for operation again as follows:

- ▶ Install the battery again (see ["Installing a battery", Page 55](#)).
- ▶ Turn the notebook the right way up again and place it on a flat surface.
- ▶ Reconnect the cables that you disconnected before.

Settings in BIOS Setup Utility

The *BIOS Setup Utility* allows you to set the system functions and the hardware configuration for the notebook.

When it is delivered, the notebook is set to factory default settings. You can change these settings in *BIOS Setup Utility*. Any changes you make take effect as soon as you save and exit the *BIOS Setup Utility*.

The *BIOS Setup Utility* program contains the following menus:

<i>About</i>	Displays information relating to the BIOS, processor and notebook
<i>System</i>	Advanced system settings
<i>Advanced</i>	Configuration of various hardware components, such as mouse, keyboard, processor
<i>Security</i>	Password settings and security functions
<i>Boot</i>	Configuration of the start-up sequence
<i>Exit</i>	Exits the <i>BIOS Setup Utility</i>

Starting the BIOS Setup Utility

- ▶ Reboot the notebook (switch off/on or reboot the operating system).
- ↳ The following or a similar display appears on the screen at start-up:

<F2> BIOS Setup <F12> Boot Menu

- ▶ Press the function key **[F2]**.
- ▶ If a password has been assigned, enter the password and press the Enter key.



If you have forgotten the password, contact your system administrator or contact our customer service centre.

The *BIOS Setup Utility* starts.

Operating BIOS Setup Utility



Press the **[F1]** key to display help on the operation of *BIOS Setup Utility*. The description of the individual settings is shown in the right-hand window of the *BIOS Setup Utility*.

With the **[F9]** key you can load the default settings of the *BIOS Setup Utility*.

- ▶ Use the cursor keys **[←]** or **[→]** to select the menu you wish to access to make changes.
- ↳ The menu is displayed on the screen.
- ▶ Select the option you want to change with the cursor keys **[↑]** or **[↓]**.
- ▶ Press the Enter key.
- ▶ Press the **[ESC]** key to exit the selected menu.
- ▶ For future reference, make a note of the changes you have made (for example, in this manual).

Exiting BIOS Setup Utility

You need to select the desired option in the *Exit* menu and activate it by pressing the Enter key:

Exit Saving Changes - save changes and exit BIOS Setup Utility

- ▶ To save the current menu settings and exit the *BIOS Setup Utility*, select *Exit Saving Changes* and *Yes*.
- ↳ The notebook is rebooted and the new settings come into effect.

Exit Discarding Changes – Discard changes and exit BIOS Setup Utility

- ▶ To discard the changes, select *Exit Discarding Changes* and *Yes*.
- ↳ The settings in place when *BIOS Setup Utility* was called remain effective. *BIOS Setup Utility* is terminated and the notebook is rebooted.

Load Setup Defaults – Copy Standard Entries

- ▶ To copy the standard entries for all menus of the *BIOS Setup Utility*, choose *Load Setup Defaults* and *Yes*.

Discard Changes – Discard changes without exiting the BIOS Setup Utility

- ▶ To discard the changes you have made, select *Discard Changes* and *Yes*.
- ↳ The settings in place when *BIOS Setup Utility* was called remain effective. You can now make additional settings in the *BIOS Setup Utility*.
- ▶ If you want to exit *BIOS Setup Utility* with these settings, select *Exit Saving Changes* and *Yes*.

Save Changes - save changes without exiting the BIOS Setup Utility

- ▶ To save the changes, select *Save Changes* and *Yes*.
- ↳ The changes are saved. You can now make additional settings in the BIOS Setup Utility.
- ▶ If you want to exit BIOS Setup Utility with these settings, choose *Exit Saving Changes* and *Yes*.

Save Changes and Power Off

- ▶ To save the changes and switch off your device, select *Save Changes and Power Off* and *Yes*.
- ↳ The changes are saved. Your device is shut down.

Troubleshooting and tips



Refer to the safety information in the "Safety" manual when connecting or disconnecting cables.

If a fault occurs, try to correct it as described. If you fail to correct the problem, proceed as follows:

- ▶ Make a note of the steps and the circumstances that led to the fault. Also make a note of any error messages displayed.
- ▶ Switch the notebook off.
- ▶ Please contact the Hotline/Service Desk.



You can find the telephone numbers in the service desk list. Please have the following information ready when you call:

- The model name and serial number of the notebook. The serial number is located on a sticker on the underside of the notebook.
- Notes of any messages that appear on the screen and information on acoustic signals.
- Any changes you have made to the hardware or software since receiving the notebook.
- Any changes you have made to the *BIOS Setup* settings since receiving the notebook.
- Your system configuration and all peripheral devices connected to your system.
- Your sales contract.



Our notebooks have been designed primarily with mobile applications in mind. This means that considerable effort has been made to optimise components and equipment in terms of weight, space and energy requirements. Depending on the particular configuration you have purchased, it is possible that functionality may be slightly reduced compared to a desktop PC if you are running processor-intensive gaming software, e.g. games with intensive 3D graphics. Updating your hardware with drivers which have not been approved by Fujitsu Technology Solutions may result in performance losses, data losses or malfunction of the equipment. A list of approved drivers and current BIOS versions can be downloaded from: ["http://ts.fujitsu.com/support/downloads.html"](http://ts.fujitsu.com/support/downloads.html)

Help if problems occur

Should you at any time have a problem with your computer that you can't solve yourself, in many cases you can quickly solve it by using the *SystemDiagnostics* program which is pre-installed on your computer.



The *SystemDiagnostics* program is already installed on devices which were delivered with a Windows operating system.

- ▶ To start the *SystemDiagnostics* program, click on *Startsymbol - Program - Fujitsu - SystemDiagnostics*.
- ▶ If a problem is found during a test run, the *SystemDiagnostics* program outputs a code (e.g. DIFS-Code YXXX123456789123).
- ▶ Make a note of the output DIFS code and the identity number of your device. The identity number can be found on the type rating plate on the back of the casing.
- ▶ For further clarification of the problem, contact the Service Desk for your country (see the Service Desk list or visit the Internet at "<http://ts.fujitsu.com/support/serviceesk.html>"). When you do this, please have ready the identity number and serial number of your system and the DIFS code.

The notebook's date or time is incorrect

Cause	Troubleshooting
Time and date are incorrect.	▶ With the <i>BIOS-Setup-Utility</i> , you can set the date and time in the <i>main</i> menu.



If the date and time are repeatedly incorrect when you switch on the notebook, the built-in battery that supplies the internal clock has failed.

- ▶ Please contact your sales outlet or our Hotline/Service Desk.

Battery indicator does not illuminate

Cause	Fault elimination
The battery is not installed correctly.	<ul style="list-style-type: none"> ▶ Switch the notebook off. ▶ Check whether the battery is installed correctly in its compartment. ▶ Switch the notebook on.
The battery is fully discharged.	<ul style="list-style-type: none"> ▶ Charge the battery. <p>or</p> <ul style="list-style-type: none"> ▶ Install a charged battery. <p>or</p> <ul style="list-style-type: none"> ▶ Connect the notebook to a mains outlet using the mains adapter.

When certain characters are entered on the keyboard, only numerals are written

Cause	Troubleshooting
The virtual numeric keypad of your device is activated, see " Virtual numeric keypad ", Page 44	▶ Press the [Num] key.

The notebook's LCD screen remains blank

Cause	Troubleshooting
Monitor is switched off.	▶ Press a key or touch the touchpad.
External monitor or television set connected.	▶ Press the key combination to switch the screen output, see " Key combinations ", Page 45 .

The LCD screen is difficult to read

Cause	Troubleshooting
Reflected glare	▶ Turn the notebook or alter the tilt of the LCD screen. ▶ Increase the brightness of the screen.

The external monitor remains blank

Cause	Troubleshooting
Monitor is switched off.	▶ Switch the external monitor on.
Power saving has been activated (monitor is blank).	▶ Press any key to continue.
Brightness is set to dark.	▶ Adjust the brightness of the monitor.
Screen output is set to the notebook's LCD screen	▶ Press the key combination to switch the screen output, see " Key combinations ", Page 45 .
The external monitor's power cable or data cable is not connected properly.	▶ Switch off the external monitor and the notebook. ▶ Check whether the power cable is plugged properly into the external monitor and into the power socket. ▶ Check whether the data cable is properly connected to the notebook and the external monitor (if it is plugged in with a connector). ▶ Switch on the external monitor and the notebook.

The external monitor is blank or the image is unstable

Cause	Troubleshooting
<p>The wrong external monitor has been selected or the wrong screen resolution has been set for the application program.</p>	<ul style="list-style-type: none"> ▶ Terminate the application program in Windows by pressing [Alt] + [F4]. If the fault persists after closing the program, use the key combination for switching the screen output (see "Key combinations", Page 45) to switch over to the notebook's LCD screen. Change the following setting: ▶ Set the screen resolution: Set the screen resolution as described in the documentation for your operating system. ▶ Select monitor: Select monitor 1 or 2 as described in the documentation for your operating system.

The cursor does not correctly follow the pen movements

Cause	Fault elimination
<p>Pen incorrectly calibrated</p>	<p>Windows XP</p> <ul style="list-style-type: none"> ▶ Calibrate the pen as shown under <i>Tablet and Pen Settings</i> in the Control Panel, see "Setting the pen", Page 38 and "Calibrating the pen", Page 38. <p>Windows Vista</p> <ul style="list-style-type: none"> ▶ Calibrate the pen as shown under <i>Tablet PC Settings</i> in the Control Panel, see "Setting the pen", Page 38 and "Calibrating the pen", Page 38. <p>Windows 7</p> <ul style="list-style-type: none"> ▶ Calibrate the pen as shown under <i>Hardware and Sound / Tablet PC Settings</i> in the Control Panel, see "Setting the pen", Page 38 and "Calibrating the pen", Page 38.

Pen input not working

Cause	Troubleshooting
Incorrect driver installed.	<ul style="list-style-type: none"> ▶ If your device is one which can only be operated using the pen, install the driver for the standard model. <p>or</p> <ul style="list-style-type: none"> ▶ If your device is one which can be operated using the pen and by finger, install the driver for the "Dual Digitizer" model.

The notebook cannot be started

Cause	Troubleshooting
The battery is not installed correctly.	<ul style="list-style-type: none"> ▶ Check whether the battery is installed correctly in its compartment. ▶ Switch the notebook on.
The battery is dead.	<ul style="list-style-type: none"> ▶ Charge the battery. <p>or</p> <ul style="list-style-type: none"> ▶ Insert a charged battery. <p>or</p> <ul style="list-style-type: none"> ▶ Connect the mains adapter to the notebook.
The power adapter is not connected correctly.	<ul style="list-style-type: none"> ▶ Check whether the mains adapter is connected correctly to the notebook. ▶ Switch the notebook on.

The notebook stops working

Cause	Troubleshooting
Notebook is in energy saving mode.	<ul style="list-style-type: none"> ▶ Leave energy saving mode.
An application programme has caused the malfunction.	<ul style="list-style-type: none"> ▶ Close the application program or restart the notebook (by restarting the operating system or switching the device off and back on again).
The battery is dead.	<ul style="list-style-type: none"> ▶ Charge the battery. <p>or</p> <ul style="list-style-type: none"> ▶ Insert a charged battery. <p>or</p> <ul style="list-style-type: none"> ▶ Connect the mains adapter to the notebook.

The printer does not print

Cause	Troubleshooting
The printer is not switched on.	<ul style="list-style-type: none"> ▶ Make sure that the printer is switched on and ready for operation (refer to the documentation supplied with the printer).
The printer is not connected correctly.	<ul style="list-style-type: none"> ▶ Check that the data cable connecting the notebook to the printer is properly connected.
The printer driver is faulty or not correctly installed, or it is the wrong printer driver.	<ul style="list-style-type: none"> ▶ Check that the data cable connecting the notebook to the printer is properly connected. ▶ Check whether the correct printer driver is loaded (refer to the printer documentation).

The radio connection to a network does not work

Cause	Troubleshooting
The wireless component is disabled.	<ul style="list-style-type: none"> ▶ Switch the radio component on (see "Switching the wireless components on and off", Page 69).
The wireless component is enabled. Despite this, the wireless connection to a network does not work.	<ul style="list-style-type: none"> ▶ Check whether the radio connection is switched on via the software. ▶ Further information on using the radio component can be found in the help files.

The battery discharges too quickly

Cause	Troubleshooting
The battery is either too hot or too cold. In this case the battery indicator flashes.	<ul style="list-style-type: none"> ▶ Bring the notebook up/down to a normal temperature again. ▶ If the operating time of the battery life is extremely short, the battery is probably too old. Replace battery if necessary.
You may have an application running that consumes a great deal of power due to frequent accessing of the hard disk or optical drive.	<ul style="list-style-type: none"> ▶ Use the mains adapter as frequently as possible.
The maximum brightness may have been set for the screen.	<ul style="list-style-type: none"> ▶ Set the screen slightly darker with the key combination for <i>Decreasing the screen brightness</i> in order to reduce the amount of power being drawn.

SmartCard reader is not recognised.

Cause	Troubleshooting
Chip card inserted incorrectly.	<ul style="list-style-type: none"> ▶ Make sure you have inserted your SmartCard into the SmartCard reader with the chip facing upwards. ▶ Check whether the SmartCard you are using is supported. Your SmartCard must comply with the ISO standard 7816-1, -2, -3 and -4.

SmartCard PIN forgotten

Cause	Troubleshooting
PIN forgotten	<ul style="list-style-type: none"> ▶ If you are working in a network, contact your system administrator, who can unlock your notebook with a Supervisor PIN.

SmartCard lost

Cause	Troubleshooting
SmartCard lost	<ul style="list-style-type: none"> ▶ If you are working in a network, contact your system administrator, who can boot up your notebook with a Supervisor SmartCard.

User and/or supervisor SmartCard lost

Cause	Troubleshooting
User and/or supervisor SmartCard lost	<ul style="list-style-type: none"> ▶ If you have lost your User SmartCard, you can continue working with the Supervisor SmartCard and initialise a new User SmartCard or deactivate the SystemLock function. ▶ If you have lost the Supervisor SmartCard, you can continue working, but you no longer have all your rights and can no longer initialise a Supervisor SmartCard. ▶ If you have lost both SmartCards, you can no longer boot your system. Please contact our Service Desk. You must provide proof of ownership for the device. Then the Service Desk will refer you to our service partner, who will unlock your device (for a charge).

Acoustic warnings

Cause	Troubleshooting
A beep sounds every few seconds The battery is almost flat.	▶ Charge the battery.

Error messages on the screen

This section describes the error messages generated by the BIOS Setup. Error messages displayed by the operating system or programmes are described in the relevant documentation.



If the error message appears repeatedly, despite troubleshooting measures, please contact the place of purchase or our customer service centre.

Error message/cause	Resolution
<i>CMOS battery bad</i> If the error message occurs repeatedly, the buffer battery in the notebook is flat.	▶ Contact your sales outlet or our customer service centre.
<i>System CMOS checksum bad - default configuration used</i> The system configuration information is incorrect.	<ul style="list-style-type: none"> ▶ Switch the notebook off. ▶ Switch the notebook on. ▶ Press the function key F2 to access the <i>BIOS Setup</i>. ▶ In the <i>BIO Setup</i>, select the <i>Exit</i> menu. ▶ Select the entry <i>Load Setup Defaults</i>. ▶ Select <i>OK</i> and press the Enter key.
<i>Extended memory failed at offset: xxxx Failing Bits: zzzz zzzz</i> When testing the extended memory an error has resulted at the address xxxx.	▶ Check whether the additional memory module has been inserted correctly.
<i>Failure Fixed Disk n</i> The settings of the hard disk drive are incorrect.	▶ Start the <i>BIOS Setup (Primary Master submenu)</i> and select the correct settings.
<i>Keyboard controller error</i>	<ul style="list-style-type: none"> ▶ Switch the notebook off with the ON/OFF switch. ▶ Wait 3 - 5 seconds and switch on the notebook again.
<i>Keyboard error</i>	<p>If you are using an external keyboard:</p> <ul style="list-style-type: none"> ▶ Check the connection and reboot the notebook.
<i>nn Stuck key</i>	▶ Make sure that no key is pressed.

Error message/cause	Resolution
<i>Operating system not found</i>	<ul style="list-style-type: none"> ▶ Check in the <i>BIOS Setup</i> whether your hard disk has been set correctly. ▶ Make sure that the operating system is installed on the corresponding drive.
<p><i>Press <F1> to resume, <F2> to SETUP</i></p> <p>This error message appears if an error occurs during the self-test before starting the operating system.</p>	<ul style="list-style-type: none"> ▶ Press the [F1] function key to start the operating system. ▶ Press the function key [F2] to access the <i>BIOS Setup</i>.
<p><i>Previous boot incomplete - Default configuration used</i> Due to an error during the previous system boot, default values were used for certain settings. Check the settings in the BIOS Setup.</p>	<ul style="list-style-type: none"> ▶ Press the [F1] function key when prompted to do so.
<i>Real time clock error</i>	<ul style="list-style-type: none"> ▶ Contact your sales outlet or our customer service centre.
<i>mmnK Shadow RAM failed at offset: xxxx Failing Bits: zzzz</i>	<ul style="list-style-type: none"> ▶ Contact your sales outlet or our customer service centre.
<i>System battery is dead - Replace and run SETUP</i>	<ul style="list-style-type: none"> ▶ Contact your sales outlet or our customer service centre.
<i>System cache error - Cache disabled</i>	<ul style="list-style-type: none"> ▶ Contact your sales outlet or our customer service centre.
<i>System timer error</i>	<ul style="list-style-type: none"> ▶ Contact your sales outlet or our customer service centre.

Technical data

Notebook

General	
Processor	Intel® Core™ with vPro™ technology
Main memory (SO DIMM)	Maximum 8 GByte DDR3 2 slots for 2 GByte or 4 GByte modules
Electrical data	
Safety regulations complied with	CE, TS (optional)
Protection class	II
Maximum power draw (when the notebook is switched on and the battery is charged):	80 W
LCD screen	
Size	33.8 cm TFT WXGA
Resolution	1280 x 800 pixels / 32-bit
Pixel class	II
Brightness control	8 levels
Technology	Wide-View High-Bright WXGA Display with LED Background Lighting
Digitizer and glass panel	<ul style="list-style-type: none"> • Active Digitizer with frosted Berlin glass or • Active Digitizer with shining glass or • Dual digitizer with matt touch screen
WebCam	2 mega pixel (optional)
Graphics card	
Chip	Intel® HD Graphics
Maximum resolution on external display:	1920 x 1200 pixels
Dimensions	
Width x depth x height	319 mm x 244 mm x 39 mm
Weight depending on configuration	from 2.1 kg
Input devices	
Keyboard	85 keys
Touchpad	2 keys
Tablet buttons	5 keys
Pen	1 freely programmable rocker button / eraser
Slots	
ExpressCard slot	1 x ExpressCard/34 or ExpressCard/54
Memory card slot	1 x SD or MS card

SmartCard slot	1 x
SIM card slot or modem connection	1 x
Ports	
Monitor port (analogue)	15-pin socket
LAN port	Socket, RJ45
Microphone port/Line In	3.5 mm stereo mini jack
Headphones port/Line Out	3.5 mm stereo mini jack
Docking port	80-pin socket
USB (Universal Serial Bus)	3 x USB 2.0
Kensington Lock	1 x
Ambient conditions	
Environment class DIN IEC 721	7K1
Mechanism class DIN IEC 721	7M2
Operating temperature	5 °C 35 °C
Transport temperature (2K2)	-15 °C 60 °C

Port Replicator (optional)

Electrical data	
Safety regulations complied with	CE
Protection class	II
Ports	
Monitor port (analogue)	15-pin
Monitor port (digital)	25-pin, DVI-D
HDMI port	1 x
LAN port	RJ45
USB (Universal Serial Bus)	4x USB 2.0
Audio	Line out
Docking port	80-pin
Ambient conditions	
Environment class DIN IEC 721	7K1
Mechanism class DIN IEC 721	7M2
Operating temperature	5 °C 35 °C
Transport temperature	-15 °C 60 °C

Rechargeable battery



You can find information on the batteries used in your device on the Internet at ["http://ts.fujitsu.com/support"](http://ts.fujitsu.com/support).

In addition to the main battery, you can order an optional battery which is inserted in the module slot. All rechargeable batteries are 6-cell batteries.

	Main battery	Optional battery (to be inserted in the module bay)
Rated voltage	10.8 V	10.8 V
Rated capacity	62.6 Wh	41 Wh
Nominal power	5.800 mAh	3.800 mAh



The operating time depends on the device configuration, the active applications and the energy-saving settings.

Mains adapter



The following technical data applies to the mains adapter supplied with the notebook and to the mains adapter supplied with the port replicator which you can order optionally.

Primary	
Rated voltage	100 V to 240 V (automatic)
Rated frequency	50 Hz to 60 Hz (automatic)
Max. rated current	0.7 A to 1.2 A
Secondary	
Nominal power	80 W
Rated voltage	19 V
Max. rated current	4.22 A



An additional mains adapter or power cable can be ordered at any time.

Manufacturer's notes

Energy Star



Devices which are certified according to the Energy Star environmental mark help to save money and reduce the emission of greenhouse gases.

Power Management settings on delivery:

- Monitor switched off after < 15 minutes of inactivity
- Automatic activation of energy saving mode (ACPI S3): < 30 minutes of inactivity

Detailed information about the requirements of the "Energy Star" environmental mark and the products which satisfy these requirements can be found on the Internet at "<https://www.energystar.gov/>".

Disposal and recycling

Information about this subject can be found on your notebook or on our Internet pages.

Declarations of Conformity

The "Declarations of Conformity" concerning the device can be found at our Internet address: "<http://ts.fujitsu.com/>".

Fujitsu Technology Solutions hereby declares that your device is in compliance with the essential requirements and other relevant provisions of Directive 1999/5/EC.

Tested safety (TS, depending on the device)



With the AntiGlare display, the device meets the requirements of the following directives:

- EN60950-1:2001
- DIN EN ISO 13406-2:2003
- EK1-ITB 2000:2008
- DIN EN ISO 9241-4:1999

CE marking



CE marking for devices with radio component

This equipment complies with the requirements of Directive 1999/5/EC of the European Parliament and Commission from 9 March, 1999 governing Radio and Telecommunications Equipment and mutual recognition of conformity.

This equipment can be used in the following countries:

Belgium	Bulgaria	Denmark	Germany
Estonia	Finland	France	Greece
UK	Ireland	Iceland	Italy
Latvia	Liechtenstein	Lithuania	Luxembourg
Malta	The Netherlands	Norway	Austria
Poland	Portugal	Rumania	Sweden
Switzerland	Slovakia	Slovenia	Spain
Czech Republic	Hungary	Cyprus	

Contact the corresponding government office in the respective country for current information on possible operating restrictions. If your country is not included in the list, then please contact the corresponding supervisory authority as to whether the use of this product is permitted in your country.

Regulatory notices



If there is no FCC logo and also no FCC ID on the device then this device is not approved by the Federal Communications Commission (FCC) of the USA. Although it is not explicitly forbidden to travel in the US trading area carrying this device, to avoid trouble at customs clearance, Fujitsu Technology Solutions GmbH recommends not to bring this device into the US trading area.

Regulatory information for notebooks without radio device

NOTICE:

Changes or modifications not expressly approved by Fujitsu Technology Solutions could void this user's authority to operate the equipment.

Notice to Users of Radios and Television

These limits are designed to provide reasonable protection against harmful interference in a residential installation. This equipment generates, uses, and can radiate radio frequency energy and, if not installed and used in accordance with the instructions, may cause harmful interference to radio communications. However, there is no guarantee that interference will not occur in a particular installation. If this equipment does cause harmful interference to radio or television reception, which can be determined by turning the equipment off and on, the user is encouraged to try to correct the interference by one or more of the following measures:

- Reorient or relocate the receiving antenna.
- Increase the separation between the equipment and receiver.

- Connect the equipment into an outlet that is on a different circuit than the receiver.
- Consult the dealer or an experienced radio/TV technician for help.

Notice to Users of the US Telephone Network

Your notebook may be supplied with an internal modem which complies with Part 68 of the FCC rules. On this notebook is a label that contains the FCC Registration Number and the Ringer Equivalence Number (REN) for this equipment among other information. If requested, the user must provide their telephone company with the following information:

1. The telephone number to which the notebook is connected.
2. The Ringer Equivalence Number (REN) for this equipment.
3. The equipment requires a standard modular jack type USOC RJ-11C which is FCC Part 68 compliant.
4. The FCC Registration Number.

This equipment is designed to be connected to the telephone network or premises wiring using a standard modular jack type USOC RJ-11C which is FCC Part 68 compliant and a line cord between the modem and the telephone network with a minimum of 26AWG.

The REN is used to determine the number of devices that you may connect to your telephone line and still have all of those devices ring when your number is called. Too many devices on one line may result in failure to ring in response to an incoming call. In most, but not all, areas the sum of the RENs of all of the devices should not exceed five (5). To be certain of the number of devices you may connect to your line, as determined by the RENs, contact your local telephone company. If this equipment causes harm to the telephone network, your telephone company may discontinue your service temporarily. If possible, they will notify you in advance. If advance notice is not practical they will notify you as soon as possible. You will also be advised of your right to file a complaint with the FCC.

This fax modem also complies with fax branding requirements per FCC Part 68.

Your telephone company will probably ask you to disconnect this equipment from the telephone network until the problem is corrected and you are sure that the equipment is not malfunctioning. This equipment may not be used on coin-operated telephones provided by your telephone company. Connection to party lines is subject to state tariffs. Contact your state's public utility commission, public service commission or corporation commission for more information.

This equipment includes automatic dialing capability. When programming and/or making test calls to emergency numbers:

- Remain on the line and briefly explain to the dispatcher the reason for the call.
- Perform such activities in off-peak hours, such as early morning or late evening.

FCC rules prohibit the use of non-hearing aid compatible telephones in the following locations or applications:

- All public or semi-public coin-operated or credit card telephones.
- Elevators, highways, tunnels (automobile, subway, railroad or pedestrian) where a person with impaired hearing might be isolated in an emergency.
- Places where telephones are specifically installed to alert emergency authorities such as fire, police or medical assistance personnel.
- Hospital rooms, residential health care facilities, convalescent homes and prisons.
- Hotel, motel or apartment lobbies.
- Stores where telephones are used by patrons to order merchandise.

- Public transportation terminals where telephones are used to call taxis or to reserve lodging or rental cars.
- In hotel and motel rooms as at least ten percent of the rooms must contain hearing aid-compatible telephones or jacks for plug-in hearing aid compatible telephones which will be provided to hearing impaired customers on request.

DOC (Industry CANADA) notices

Notice to Users of Radios and Television

This Class B digital apparatus meets all requirements of Canadian Interference-Causing Equipment Regulations.

CET appareil numérique de la class B respecte toutes les exigence du Règlement sur le matériel brouilleur du Canada.

Notice to Users of the Canadian Telephone Network

NOTICE:

This equipment meets the applicable Industry Canada Terminal Equipment Technical Specifications. This is confirmed by the registration number. The abbreviation, IC, before the registration number signifies that registration was performed based on a Declaration of Conformity indicating that Industry Canada technical specifications were met. It does not imply that Industry Canada approved the equipment. Before connecting this equipment to a telephone line the user should ensure that it is permissible to connect this equipment to the local telecommunication facilities. The user should be aware that compliance with the certification standards does not prevent service degradation in some situations.

Repairs to telecommunication equipment should be made by a Canadian authorised maintenance facility. Any repairs or alterations not expressly approved by Fujitsu or any equipment failures may give the telecommunication company cause to request the user to disconnect the equipment from the telephone line.

NOTICE:

The Ringer Equivalence Number (REN) for this terminal equipment is 0.0. The REN assigned to each terminal equipment provides an indication of the maximum number of terminals allowed to be connected to a telephone interface. The termination on an interface may consist of any combination of devices subject only to the requirement that the sum of the Ringer Equivalence Numbers of all the devices does not exceed five.



CAUTION:

For safety, users should ensure that the electrical ground of the power utility, the telephone lines and the metallic water pipes are connected together. Users should NOT attempt to make such connections themselves but should contact the appropriate electric inspection authority or electrician. This may be particularly important in rural areas.

Avis Aux Utilisateurs Du Réseau Téléphonique Canadien

AVIS : Le présent matériel est conforme aux spécifications techniques d'Industrie Canada applicables au matériel terminal. Cette conformité est confirmée par le numéro d'enregistrement. Le sigle IC, placé devant le numéro d'enregistrement, signifie que l'enregistrement s'est effectué conformément à une déclaration de conformité et indique que les spécifications techniques d'Industrie Canada ont été respectées. Il n'implique pas qu'Industrie Canada a approuvé le matériel.

Avant de connecter cet équipement à une ligne téléphonique, l'utilisateur doit vérifier s'il est permis de connecter cet équipement aux installations de télécommunications locales. L'utilisateur est averti que même la conformité aux normes de certification ne peut dans certains cas empêcher la dégradation du service.

Les réparations de l'équipement de télécommunications doivent être effectuées par un service de maintenance agréé au Canada. Toute réparation ou modification, qui n'est pas expressément approuvée par Fujitsu, ou toute défaillance de l'équipement peut entraîner la compagnie de télécommunications à exiger que l'utilisateur déconnecte l'équipement de la ligne téléphonique.

AVIS : L'indice d'équivalence de la sonnerie (IES) du présent matériel est de 0.0. L'IES assigné à chaque dispositif terminal indique le nombre maximal de terminaux qui peuvent être raccordés à une interface téléphonique. La terminaison d'une interface peut consister en une combinaison quelconque de dispositifs, à la seule condition que la somme d'indices d'équivalence de la sonnerie de tous les dispositifs n'excède pas 5.



AVERTISSEMENT:

Pour assurer la sécurité, les utilisateurs doivent vérifier que la prise de terre du service d'électricité, les lignes téléphoniques et les conduites d'eau métalliques sont connectées ensemble. Les utilisateurs NE doivent PAS tenter d'établir ces connexions eux-mêmes, mais doivent contacter les services d'inspection d'installations électriques appropriés ou un électricien. Ceci peut être particulièrement important en régions rurales.

UL Notice

This unit requires an AC adapter to operate. Only use a UL Listed Class 2 adapter. The correct output rating is indicated on the AC adapter label. Refer to the illustration below for the correct AC Adapter output polarity:



CAUTION:

To reduce the risk of fire, use only 26AWG or larger telecommunications line cord.

For Authorized Repair Technicians Only



CAUTION:

For continued protection against risk of fire, replace only with the same type and rating fuse.



WARNING:

Danger of explosion if Lithium (CMOS) battery is incorrectly replaced. Replace only with the same or equivalent type recommended by the manufacturer.

Dispose of used batteries according to the manufacturer's instructions.

FCC Regulatory information for notebooks with radio device

Federal Communications Commission statement

This device complies with Part 15 of FCC Rules. Operation is subject to the following two conditions: (1) this device may not cause interference, and

(2) this device must accept any interference, including interference that may cause undesired operation of this device.

FCC Interference Statement

This equipment has been tested and found to comply with the limits for a Class B digital device, pursuant to Part 15 of the FCC Rules. These limits are designed to provide reasonable protection against harmful interference in a residential installation. This equipment generates, uses, and can radiate radio frequency energy. If not installed and used in accordance with the instructions, it may cause harmful interference to radio communications.

However, there is no guarantee that interference will not occur in a particular installation.

If this equipment does cause harmful interference to radio or television reception, which can be determined by turning the equipment off and on, the user is encouraged to try to correct the interference by one or more of the following measures:

1. Reorient or relocate the receiving antenna.
2. Increase the distance between the equipment and the receiver.
3. Connect the equipment to an outlet on a circuit different from the one the receiver is connected to.
4. Consult the dealer or an experienced radio/TV technician for help.

Please note the following regulatory information related to the optional radio device.

FCC Radio Frequency Exposure statement

This radio device has been evaluated under FCC Bulletin OET 65C and found compliant with the requirements as set forth in CFR 47 Sections 2.1091, 2.1093, and 15.247 (b) (4) addressing RF Exposure from radio frequency devices. The radiated output power of this radio device is far below the FCC radio frequency exposure limits. Nevertheless, this device shall be used in such a manner that the potential for human contact during normal operation is minimized. When using this device, a certain separation distance between antenna and nearby persons must be maintained to ensure RF exposure compliance. In order to comply with RF exposure limits established in the ANSI C95.1 standards, the distance between the antennas and the user should not be less than 20 cm (8 inches).

Regulatory Notes and Statements

Radio device, health and authorisation for use

Radio-frequency electromagnetic energy is emitted from the wireless devices. The energy levels of these emissions, however, are far much less than the electromagnetic energy emissions from wireless devices such as mobile phones. Radio devices are safe for use by consumers because they operate within the guidelines found in radio frequency safety standards and recommendations.

The use of the radio devices may be restricted in some situations or environments, such as:

- on board an airplane, or
- in an explosive environment, or
- in situations where the interference risk to other devices or services is perceived or identified as harmful.

In cases in which the policy regarding use of radio devices in specific environments is not clear (e.g., airports, hospitals, chemical/oil/gas industrial plants, private buildings), obtain authorization to use these devices prior to operating the equipment.

Regulatory Information/Disclaimers

Installation and use of this radio device must be in strict accordance with the instructions included in the user documentation provided with the product. Any changes or modifications made to this device that are not expressly approved by the manufacturer may void the user's authority to operate the equipment. The manufacturer is not responsible for any radio or television interference caused by unauthorized modification of this device, or the substitution or attachment of connecting cables and equipment other than those specified by the manufacturer. It is the responsibility of the user to correct any interference caused by such unauthorized modification, substitution or attachment. The manufacturer and its authorized resellers or distributors will assume no liability for any damage or violation of government regulations arising from failure to comply with these guidelines.

Export restrictions

This product or software contains encryption code which may not be exported or transferred from the US or Canada without an approved US Department of Commerce export license. This device complies with Part 15 of FCC Rules, as well as ICES 003 B / NMB 003 B. Operation is subject to the following two conditions:

- (1) this device may not cause harmful interference, and
- (2) this device must accept any interference received, including interference that may cause undesirable operation.

Modifications not expressly authorised by Fujitsu Technology Solutions may invalidate the user's right to operate this equipment.

Index

- A**
 - A beep sounds every second 107
 - Acoustic error messages 112
 - Administrator functions 85
 - Anti-theft protection 71
 - Audio devices, connecting 96
 - Audio ports 96–97
- B**
 - Backspace 36
 - Bass loudspeaker (subwoofer) 60
 - Battery
 - battery life 47
 - caring for and maintaining 47
 - charge level 47, 56
 - charging 47
 - self-discharge 48
 - storage 48
 - Battery status meter 47
 - Battery:
 - discharges too quickly 110
 - BIOS Setup Utility
 - calling 103
 - exiting 104
 - operating 103
 - protecting with password 72
 - settings 103
 - Bluetooth
 - Switching off module 63
 - Switching on module 63
 - Bluetooth, safety notes 8
 - Board 98
 - Buffer battery, load 106
 - Buttons 36
- C**
 - Caps Lock 37
 - CD/DVD indicator 53
 - CD/DVD:
 - manual emergency removal 54
 - CE marking 118
 - Charging capacity, battery 48
 - Cleaning 10
 - Components
 - installing / removing 98
 - Configuration, BIOS Setup Utility 103
 - Connecting audio devices 96–97
 - Connecting headphones 97
 - Crystal View display
 - cleaning 10
 - Cursor control keys 37
 - Cursor keys 37
- D**
 - Date is incorrect 106
 - Declaration of conformity 117
 - Device
 - setting up 12
 - Devices
 - connecting 92
 - disconnecting 92
 - Display orientation
 - selecting 21
 - DOC (INDUSTRY CANADA) NOTICES 120
 - Drive
 - Removing 51
- E**
 - Emergency removal of data carrier 54
 - Energy
 - energy saving 8
 - Energy saving 8
 - Energy saving mode
 - leaving 109
 - Enter 37
 - Enter key 37
 - Error message:
 - on the screen 112
 - Error messages
 - Mainboard 89
 - Error messages on the screen 112
 - Errors
 - Acoustic warnings 112
 - ESD 98
 - Ethernet LAN 64
 - ExpressCard 59
- F**
 - F10, function key 82
 - F2, function key 88
 - F3, function key 88
 - F5, function key 82, 84
 - F6, function key 82, 84
 - F7, function key 82
 - F8, function key 82, 84
 - F9, function key 82, 84
 - Fault
 - correction 105

- Fingerprint sensor 71
 - configure 71
- FireWire
 - connecting devices 96
- FireWire:
 - port 96
- First-time setup 11
- Fn + F10 40
- Fn key 37

- G**
- Getting started 11

- H**
- Handling
 - data carriers 52
- Hardware configuration 103
- HDMI port 94

- I**
- Important notes 7
- Incorrect date/time 106
- Inserting
 - a data carrier 53
- Installing SystemLock 80

- K**
- Kensington MicroSaver 71
- Keyboard 36
 - cleaning 10

- L**
- Landscape orientation
 - screen 21
- Language
 - operating system 25
- Language selection 25
- LCD screen
 - cleaning 10
 - difficult to read 107
 - notes 27
 - reflected glare 107
 - remains blank 107
- LCD screen is too dark 107
- Life, battery 47
- Line feed 37
- Loudspeakers 60

- M**
- Main memory
 - see Adding memory 100
- Mains adapter
 - connecting 12
 - setting up 12
- Manual removal of data carrier 54
- Mechanical backup 71
- Memory card
 - handling 57
 - inserting 57
 - removing 58
- Memory expansion
 - installing 101
 - removing 101
- Memory module
 - important notes 100
 - installing 101
 - removing 101
- Microphone 60
- Microphone, connecting 96
- Mobile operation 9
- Module
 - Removing 51
- Module bay 51
- Modules 51
- Monitor
 - connecting 93
 - drifting display 108
 - remains blank 107
- Monitor port
 - see VGA connection socket 93

- N**
- Notebook
 - before you travel 9
 - cannot be started 109
 - cleaning 10
 - stops working 109
 - switching off 24
 - transporting 9
 - using 14
- Notebook, operation 14
- Notebook: switching on 16
- Notes 7
 - boards 98
 - cleaning 10
 - disposal / recycling 117
 - energy saving 8
 - LCD screen 27
 - Safety 7
 - transport 9
- Num Lock
 - indicator 38

Numeric keypad 36
 see Virtual numeric keypad 38

O
Operating system
 activating system protection 73
 cancel system protection 73
 protecting with password 73
Operating system language 25
Optical drive 52

P
Packaging 11
Password
 changing 73
 entering 72
 removing 73
Password protection 72
Password protection:
 hard disk 74
Peripheral devices
 connecting 92
 disconnecting 92
Portrait orientation
 screen 21
Power
 power consumption 56
 power-management features 56
Power-on indicator 16
Preparing for operation 12
Printer does not print 110

R
Radio component:
 safety notes 8
Rechargeable battery 47
 see Battery 47
Regulatory information
 notebooks with radio device 122
 Notebooks without radio device 118
Removing
 a data carrier 53
Removing memory
 see Adding memory 100
Return 37

S
Safety notes 7
Screen
 no screen display 108
Screen port

 see VGA connection socket 93
Security functions 69
 SystemLock 75
Security functions,
 SmartCard 75
Select the language: for handwriting recognition
 and keyboard 26
Select the language: for menu texts 25
Selecting a location 12
Self-discharge, battery 48
Servicing 98
Setup
 see BIOS Setup Utility 103
Shift 37
Shift key 37
Slot
 ExpressCard 59
 Memory cards 57
 SmartCard 77
 access rights 78
 PIN 78
 PUK 78
 user groups 79
Start key 37
Status indicators 14
Summer time 106
Supervisor password
 changing 73
 entering 72
 removing 73
Suspend/Resume button 16
Switching on for the first time 13
Switching on the system 77
Symbols
 indicators 14
System configuration 103
System expansion 100
 see Adding memory 100
System settings, BIOS Setup Utility 103
SystemLock
 switching on 88
SystemLock 2
 installing 83

T
Tab key 36
The radio connection to a network does
 not work 110
Time not correct 106
Time, daylight savings 106
Tips 105
Toggle output screen 40

- Touchpad 34
 - buttons 34
 - cleaning 10
 - dragging items 35
 - executing commands 34
 - moving the pointer 34
 - selecting an item 34
- TPM 90
- Transport
 - Transport damage 11
- Transportation 9
- Travel, notebook 9
- Troubleshooting 105
- Trusted Platform Module 90

U

- Uninstalling
 - SystemLock 88
- USB ports 95
- User groups
 - installing 80
- User password

- changing 73
- entering 72
- removing 73

- Using a Kensington Lock 71

V

- VGA connection socket 93
- Video devices, connecting 96
- Virtual numeric keypad 38
- Volume control 60

W

- Webcam 46
- Weight Saver
 - Removing 51
- Wireless LAN
 - Switching off module 63
 - Switching on module 63
- Wireless LAN:
 - safety notes 8