

Basler scout

AREA SCAN CAMERAS



- VGA to 2 megapixels and up to 120 fps
- Selected high quality CCD and CMOS sensors
- Gigabit Ethernet and FireWire-b interfaces
- Perfect fit for a variety of applications - extremely versatile thanks to different mounts, I/O's, and housing types

OVERVIEW

Sophisticated in Detail, Versatile and Proven Worldwide

The Basler scout family is based on a selection of the best Sony CCD sensors and offers a wide variety of resolutions and speeds. The family also includes a high-performance CMOS sensor from Aptina. With their Gigabit Ethernet (GigE) and FireWire-b™ (IEEE 1394b) interface technologies, the cameras are defined by state of the art technology that lets you get the maximum performance from each sensor.

Basler scout cameras are a perfect fit for a variety of vision applications including semiconductor and component inspection, manufacturing quality control, food and beverage inspection, intelligent traffic systems, microscopy and medical imaging, biometrics, and many others.

Outstanding Image Quality

The scout family is equipped with assorted Sony CCD sensors in mono and color. These sensors were selected to provide outstanding image quality in combination with the scout's read-out and processing electronics. For precise imaging results, all scout cameras run in progressive scan mode.

Precise Sensor Alignment

In addition to Basler's standard CTT+ automated quality assurance and calibration system, the scout camera family is tested and measured with another production tool. This unique tool is an ultrahigh precision sensor alignment device. The device automatically mounts the sensor board on the camera's front module in six degrees of freedom with reference to the optical axis.



Your benefits include:

- Resolutions from VGA to 2 megapixels with either a FireWire-b or a Gigabit Ethernet interface
- 100 meter cable length provided by Gigabit Ethernet to give you the highest flexibility
- Up to 12 bit depths and no bandwidth limitation on 8 bit data flow inside the camera
- Small, rugged housing for easy integration
- 100% quality checked and calibrated to give you consistent performance and reliability
- Field-proven Basler pylon driver package with both filter and performance drivers

TECHNICAL DETAILS

Specifications



Basler scout	Resolution (H x V pixels)	Sensor	Sensor Technology	Sensor Size (optical)	Pixel Size (µm)	Frame Rate	Power Consumption (typical)	Weight (typical)
scA640-70gm/gc	659 x 494	Sony ICX424	Progressive Scan CCD	1/3"	7.4 x 7.4	70	3 W	160 g
scA640-74gm/gc	659 x 494	Sony ICX414	Progressive Scan CCD	1/2"	9.9 x 9.9	79	3 W	160 g
scA640-120gm/gc	659 x 494	Sony ICX618	Progressive Scan CCD	1/4"	5.6 x 5.6	122	3.5 W	160 g
scA750-60gm/gc	752 x 480	Aptina MT9V022	Progressive Scan CMOS	1/3"	6.0 x 6.0	64	2.5 W	160 g
scA780-54gm/gc	782 x 582	Sony ICX415	Progressive Scan CCD	1/2"	8.3 x 8.3	55	3 W	160 g
scA1000-30gm/gc	1034 x 779	Sony ICX204	Progressive Scan CCD	1/3"	4.65 x 4.65	31	3 W	160 g
scA1300-32gm/gc	1296 x 966	Sony ICX445	Progressive Scan CCD	1/3"	3.75 x 3.75	32	3.5 W	160 g
scA1390-17gm/gc	1392 x 1040	Sony ICX267	Progressive Scan CCD	1/2"	4.65 x 4.65	17	3.5 W	160 g
scA1400-17gm/gc	1392 x 1040	Sony ICX285	Progressive Scan CCD	2/3"	6.45 x 6.45	17	3.5 W	170 g
scA1400-30gm/gc	1392 x 1040	Sony ICX285	Progressive Scan CCD	2/3"	6.45 x 6.45	30	4.2 W	170 g
scA1600-14gm/gc	1628 x 1236	Sony ICX274	Progressive Scan CCD	1/1.8"	4.4 x 4.4	14	3.5 W	160 g
scA1600-28gm/gc	1628 x 1236	Sony ICX274	Progressive Scan CCD	1/1.8"	4.4 x 4.4	28	4.3 W	160 g

Specifications Applicable For All scout GigE Models:

Mono / Color	Mono / Color
Interface	Gigabit Ethernet (screw lock possible)
Video Output Format	Mono 8: 8 bits/pixel Mono 16: 16 bits/pixel YUV 4:2:2: 16 bits/pixel average YUV 4:2:2: (YUYV):16 bits/pixel average Raw 8: 8 bits/pixel (R,G, or B) Raw 16: 16 bits/pixel (R,G, or B) scA750-60gm/gc (8 bits/pixel only)
Synchronization	Via external trigger or free run
Exposure Control	Programmable via GigE Vision (camera API)
Housing Size (L x W x H)	73.7 mm x 44 mm x 29 mm (without lens adapter)
Housing Size 90° (L x W x H)	97 mm x 44 mm x 41.8 mm (incl. lens adapter)
Housing Temperature	Up to 50 °C
Lens Mount	C-mount; CS-mount (optional)
Digital I/O	2 opto-isolated input ports, 4 opto-isolated output ports
Power Requirements	12-24 V; via Hirose 12-pin connector (max. 10 meter cable length)
Conformity	CE, FCC, RoHS, IP 30, GigE Vision, GenICam
Driver	Basler pylon driver package

Specifications are subject to change without prior notice.

For detailed technical information, see the camera User's Manual that can be found at www.baslerweb.com/manuals

TECHNICAL DETAILS



Specifications

Basler scout	Resolution (H x V pixels)	Sensor	Sensor Technology	Sensor Size (optical)	Pixel Size (µm)	Frame Rate	Power Consumption (typical)	Weight (typical)
scA640-70fm/fc	659 x 494	Sony ICX424	Progressive Scan CCD	1/3"	7.4 x 7.4	71	2.5 W	160 g
scA640-74fm/fc	659 x 494	Sony ICX414	Progressive Scan CCD	1/2"	9.9 x 9.9	74	2.5 W	160 g
scA640-120fm/fc	659 x 494	Sony ICX618	Progressive Scan CCD	1/4"	5.6 x 5.6	120	3 W	160 g
scA750-60fm/fc	752 x 480	Aptina MT9V022	Progressive Scan CMOS	1/3"	6.0 x 6.0	64	1.7 W	160 g
scA780-54fm/fc	782 x 582	Sony ICX415	Progressive Scan CCD	1/2"	8.3 x 8.3	58	2.5 W	160 g
scA1000-30fm/fc	1034 x 779	Sony ICX204	Progressive Scan CCD	1/3"	4.65 x 4.65	30	2.5 W	160 g
scA1300-32fm/fc	1296 x 966	Sony ICX445	Progressive Scan CCD	1/3"	3.75 x 3.75	33	3 W	160 g
scA1390-17fm/fc	1392 x 1040	Sony ICX267	Progressive Scan CCD	1/2"	4.65 x 4.65	17	2.75 W	160 g
scA1400-17fm/fc	1392 x 1040	Sony ICX285	Progressive Scan CCD	2/3"	6.45 x 6.45	17	3 W	170 g
scA1400-30fm/fc	1392 x 1040	Sony ICX285	Progressive Scan CCD	2/3"	6.45 x 6.45	30	3.7 W	170 g
scA1600-14fm/fc	1628 x 1236	Sony ICX274	Progressive Scan CCD	1/1.8"	4.4 x 4.4	14	2.75 W	160 g
scA1600-28fm/fc	1628 x 1236	Sony ICX274	Progressive Scan CCD	1/1.8"	4.4 x 4.4	28	4.2 W	160 g

Specifications Applicable For All scout FireWire Models:

Mono / Color	Mono / Color
Interface	IEEE 1394b (screw lock possible)
Video Output Format	Mono 8: 8 bits/pixel Mono 16: 16 bits/pixel YUV 4:2:2: 16 bits/pixel average YUV 4:2:2: (YUYV):16 bits/pixel average Raw 8: 8 bits/pixel (R,G, or B) Raw 16: 16 bits/pixel (R,G, or B) and packed formats scA750-60fm/fc (8 bits/pixel only)
Synchronization	Via external trigger, via the IEEE 1394 bus, or free run
Exposure Control	Programmable via the 1394 bus
Housing Size (L x W x H)	73.7 mm x 44 mm x 29 mm (without lens adapter)
Housing Size 90° (L x W x H)	97 mm x 44 mm x 41.8 mm (incl. lens adapter)
Housing Temperature	Up to 50 °C
Lens Mount	C-mount; CS-mount (optional)
I/O Ports	2 opto-isolated input ports, 4 opto-isolated output ports
Power Requirements	8-36 VDC; provided via the IEEE 1394 cable; < 1% ripple
Conformity	CE, FCC, DCAM, RoHS, IP 30
Driver	Basler pylon driver package

Specifications are subject to change without prior notice.

For detailed technical information, see the camera User's Manual that can be found at www.baslerweb.com/manuals

TECHNICAL DETAILS

Dimensions (in mm)

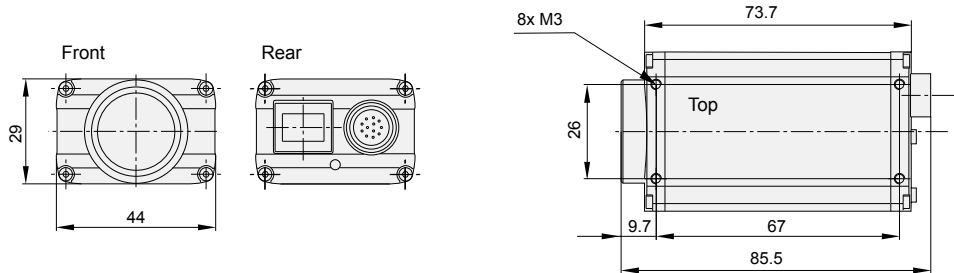

Dimensions (in mm)

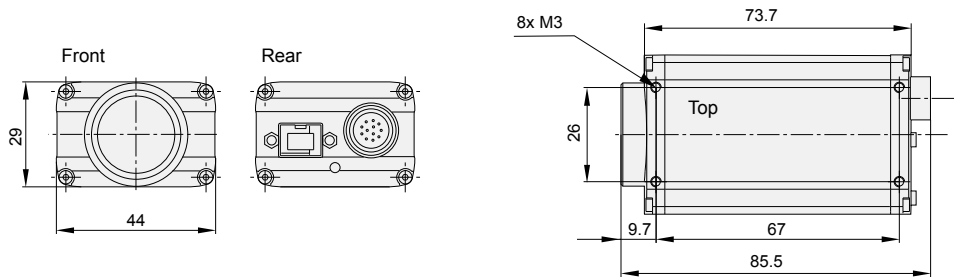

Dimensions (in mm)

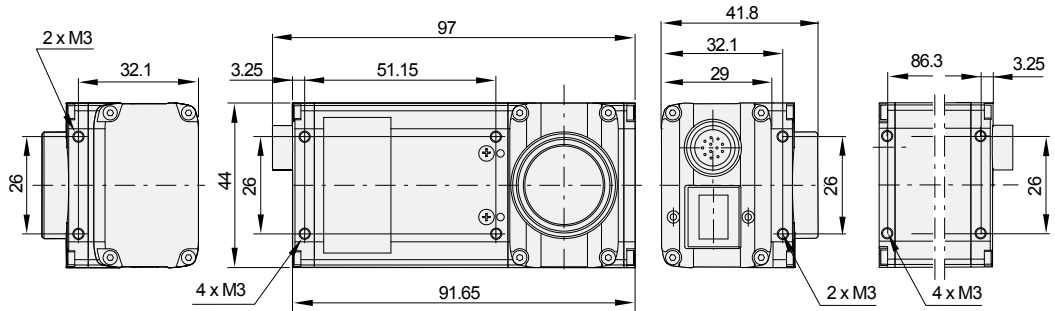

Dimensions (in mm)

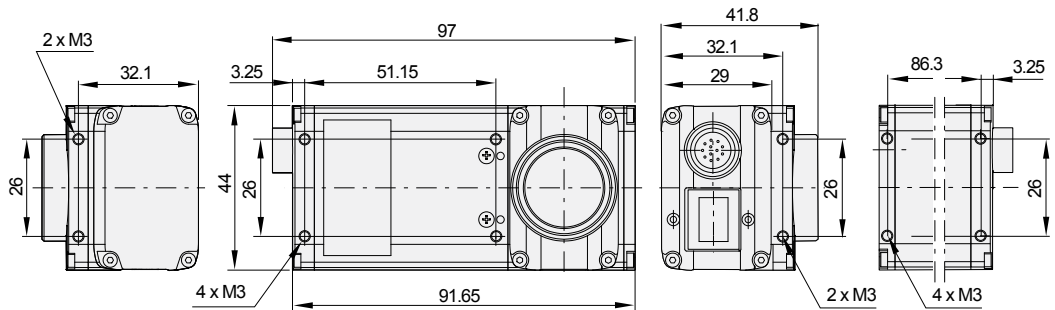

OTHER INFORMATION

Gigabit Ethernet



Gigabit Ethernet (GigE) cameras are the right choice for data rates of up to 100 MB/s and a maximum cable length of 100 meters. They make complex setups with several cameras very simple. In addition to the physical interface defined by the Gigabit Ethernet standard (among others), the especially clear and logical implementation of the GigE Vision Standard supports easy integration in all image processing programs via the use of software libraries. Also, because the exchange of GigE Vision compatible cameras can be performed without changing the application software, new investments and follow-up costs can be estimated and well-planned with cameras based on the GigE Vision Standard.

FireWire



FireWire cameras (also known as IEEE 1394 cameras) have been on the market for many years. FireWire has become a standard image data and camera command transmission mechanism. Its key benefit is real-time communication between cameras and remote computers. It supports plug-and-play and there is no need for a frame grabber. Cabling and hardware are standardized and widely used, making FireWire a cost effective solution in many cases. For FireWire cameras compliant with the DCAM/IIDC standard, a logical interface for industrial cameras is well defined. This facilitates easy integration into image processing software as well as simultaneous operation of cameras from different manufacturers.

How Does Basler Measure and Define Image Quality?



Basler is leading the effort to standardize image quality and sensitivity measurement for cameras and sensors. We are giving the EMVA 1288 standard our strongest support because it describes a unified method to measure, compute, and present the specification parameters for cameras and image sensors. Our cameras are characterized and measured in 100% compliance with the EMVA 1288 standard. Measurement reports can be downloaded from our website.

How Does Basler Ensure Superior Quality and Reliable High Performance?

Our approach to quality assurance is rigorous: we continually audit all facets of our business to guarantee performance, increase efficiency and reduce costs for our customers. We are compliant with all major quality standards including ISO9001, CE, RoHS, and more. To ensure consistently high product quality, we employ several quality inspection procedures during manufacturing.

Every Basler camera is subjected to exhaustive optical and mechanical tests before leaving the factory. We have developed a unique combination of optics, hardware, and software tools that can quickly and efficiently calibrate a camera and measure its performance against a set of standard performance criteria. Regardless of what technology or camera model you choose you can be assured of consistent performance.

3-Year Warranty

Basler offers a 3-year warranty for our cameras. We make this unprecedented promise because we have unparalleled confidence in our products. We continually reinvest in research, development and superior manufacturing capabilities so that our customers can fully rely on the products we manufacture.

Basler pylon Driver Package

The pylon driver package operates with all Basler line scan and area scan cameras. It offers stable, reliable and flexible data exchange between Basler cameras and PCs, at a very low CPU load.

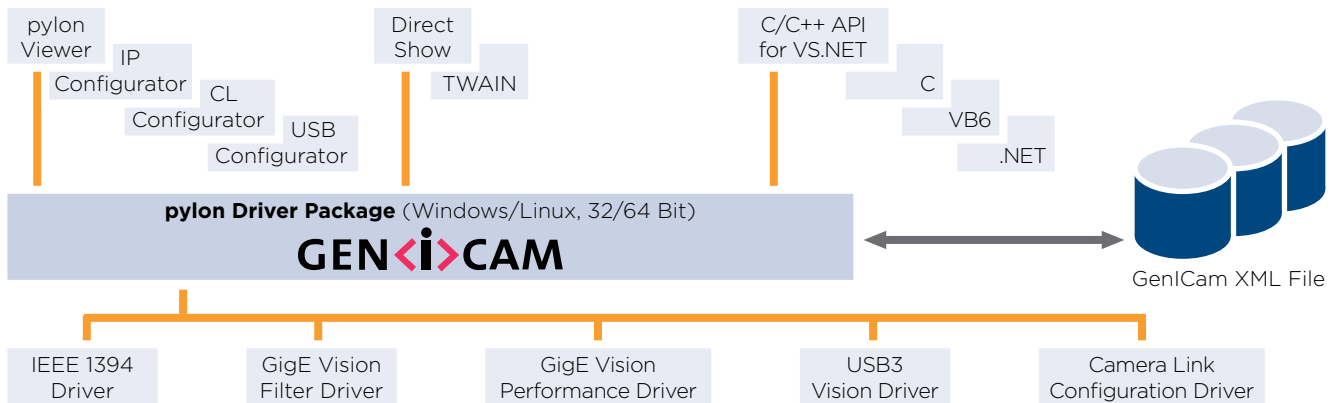

The internal architecture of the pylon driver package is based on GenICam Technology, which offers you easy access to the newest camera models and the latest features. Changes to an existing camera device in your application essentially become a plug-and-play process.

The pylon **USB3 Vision Driver** fully supports the USB3 Vision standard. It allows Basler USB 3.0 cameras to use the full speed and bandwidth of USB 3.0 for image transmission while reducing resource load and using off-the-shelf hardware components.

The pylon **GigE Vision Performance Driver** quickly separates incoming packets carrying image data from other traffic on the network and makes the data available for use by your vision application while requiring the lowest CPU resources. This driver can only be used with network cards that include specific Intel chipsets. The pylon **GigE Vision Filter Driver** supports all kinds of hardware, common GigE network cards, and GigE ports on your motherboard as well.

The pylon **IEEE 1394b Driver** gives you access to a well-established interface technology, and the pylon **Camera Link Configuration Driver** offers comfortable access to all camera parameters of Basler's latest Camera Link families ace, aviator, and racer.

The pylon Viewer offers you a convenient application for testing and evaluating Basler cameras. The pylon SDK supports any type of application development. The pylon package contains the following main modules. Each one can be individually selected/unselected during the installation process, preventing the installation of unneeded modules on your system.

- USB3 Vision Driver
- GigE Vision Filter Driver
- GigE Vision Performance Driver
- IEEE 1394 Driver
- Camera Link Serial Communication Driver
- pylon Viewer
- pylon SDK for all cameras; C, C++, .NET (C#, VB.NET, ...), and VB6 (the 'pylon for Linux' version only supports the GigE interface via a C++ API)

The pylon driver package can be downloaded for free at www.baslerweb.com/pylon. For more information on the installation process, refer to the pylon Installation Guide. The helpful pylon Release Notes contain all improvements and bug fixes since the first pylon version.

OTHER INFORMATION

About Basler

Founded in 1988, Basler is a leading global manufacturer of high quality digital cameras for industrial, medical, traffic and video surveillance applications. The company employs some 300 people at its headquarters in Ahrensburg, Germany and subsidiaries in the United States and Asia.

Basler's portfolio of products offers customers the vision industry's widest selection of industrial and network cameras. Today it includes some 300 models - and it's still growing. We're committed to developing technology that drives business results for our customers: cameras that are easy to use, easy to integrate, and deliver an exceptional price/performance ratio.



Basler AG

Germany, Headquarters

Tel. +49 4102 463 500

Fax +49 4102 463 599

sales.europe@baslerweb.com

www.baslerweb.com

USA

Tel. +1 610 280 0171

Fax +1 610 280 7608

sales.usa@baslerweb.com

Singapore

Tel. +65 6425 0472

Fax +65 6425 0473

sales.asia@baslerweb.com

Korea

Tel. +82 707 1363 114

Fax +82 707 0162 705

sales.korea@baslerweb.com