



EurotestLITE/EASI/XE
MI 3002/MI 3100/MI 3102
Instruction manual

Version 2.9, HW 3; Code No. 20 750 131

Distributor:

Manufacturer:

METREL d.d.
Ljubljanska cesta 77
1354 Horjul
Slovenia

web site: <http://www.metrel.si>
e-mail: metrel@metrel.si

© 2004 -2008 METREL



Mark on your equipment certifies that this equipment meets the requirements of the EU (European Union) concerning safety and interference causing equipment regulations.

No part of this publication may be reproduced or utilized in any form or by any means without permission in writing from METREL.

1	Preface	6
2	Safety and operational considerations	7
2.1	Warnings and notes	7
2.2	Batteries	10
2.3	Charging	10
2.4	Precautions on charging of new battery cells or cells unused for a longer period	11
2.5	Standards applied	12
3	Instrument description	13
3.1	Front panel	13
3.2	Connector panel	14
3.3	Back panel	15
3.4	Bottom view	16
3.5	Carrying the instrument	17
3.6	Instrument set and accessories	18
4	Instrument operation	19
4.1	Meaning of symbols and messages on the instrument display	19
4.1.1	The online voltage and output terminal monitor	19
4.1.2	Message field – battery status	20
4.1.3	Message field – measurement warnings/messages	20
4.1.4	Result field	21
4.1.5	Other messages	21
4.1.6	Sound warnings	22
4.1.7	Function and parameter line	22
4.2	Selecting measurement function/subfunction	22
4.3	Setting measurement parameters and limits	23
4.4	Help menu	23
4.5	Setup menu	23
4.5.1	Supply system setup	24
4.5.2	Prospective short/fault current scaling factor adjustment	24
4.5.3	Language selection	24
4.5.4	Communication port selection (MI 3102 only)	25
4.5.5	Recalling original settings	25
4.6	Display contrast adjustment	27
5	Measurements	28
5.1	Insulation resistance	28
5.2	Continuity	30
5.2.1	Low Ω resistance	30
5.2.2	Continuity	33
5.3	Testing RCDs	35
5.3.1	Limit contact voltage	35
5.3.2	Nominal differential trip-out current	35
5.3.3	Multiplier of nominal residual current	35
5.3.4	RCD type and test current starting polarity	35
5.3.5	Testing selective (time-delayed) RCDs	36
5.3.6	Contact voltage	36
5.3.7	Trip-out time	38
5.3.8	Trip-out current	40

5.3.9	Autotest	41
5.4	Fault loop impedance and prospective fault current	47
5.4.1	Fault loop impedance	47
5.4.2	RCD trip-lock function	49
5.5	Line impedance and prospective short-circuit current	51
5.6	Phase sequence testing	53
5.7	Voltage and frequency	54
5.8	Resistance to earth (MI 3102 only)	56
5.9	TRMS current (MI 3102 only)	58
5.10	Illumination (MI 3102 only)	60
5.11	Testing PE terminal	62
6	Working with results (MI 3102 only)	64
6.1	Saving results	65
6.2	Recalling results	66
6.3	Deleting results	68
7	RS232 / USB communication (MI 3102 only)	71
7.1	EuroLinkXE PC software	71
8	Maintenance	73
8.1	Replacing fuses	73
8.2	Cleaning	73
8.3	Periodic calibration	73
8.4	Service	73
9	Technical specifications	74
9.1	Insulation resistance	74
9.2	Continuity resistance	74
9.2.1	Low Ω resistance	74
9.2.2	Continuity	75
9.3	RCD testing	75
9.3.1	General data	75
9.3.2	Contact voltage	76
9.3.3	Trip-out time	76
9.3.4	Trip-out current	76
9.4	Fault loop impedance and prospective fault current	77
9.5	Line impedance and prospective short-circuit current	78
9.6	Resistance to earth	78
9.7	TRMS current	79
9.8	Illumination	79
9.8.1	Illumination (LUXmeter type B)	79
9.8.2	Illumination (LUXmeter type C)	79
9.9	Phase rotation	80
9.10	Voltage and frequency	80
9.11	Online voltage monitor	80
9.12	General data	80
A	Fuse base tables	82
A.1	Fuse base table	82
A.2	Fuse base table (UK version only)	87

B	IT supply systems	89
B.1	Standard references	89
B.2	Fundamentals	89
B.3	Measurement guides	91
B.4	Technical specifications.....	96
C	Reduced low voltage supply systems	97
C.1	Standard reference	97
C.2	Fundamentals	97
C.3	Measurement guides	97
C.4	Technical specifications.....	100
D	Accessories required for specific measurement.....	104

1 Preface

Congratulations on your purchase of the Eurotest instrument and its accessories from METREL. The instrument was designed on basis of rich experience, acquired through many years of dealing with electric installation test equipment.

The Eurotest instrument is professional, multifunctional, hand-held test instrument intended for all measurements performed for total inspection of electrical installations in buildings. The following measurements and tests can be performed:

- Voltage and frequency,
- Continuity (Low Ω and continuity function),
- Insulation resistance,
- RCD testing,
- Fault loop / RCD trip-lock impedance,
- Line impedance,
- Phase sequence,
- IMD testing (MI 3102 only),
- Resistance to earth (MI 3102 only),
- TRMS current (MI 3102 only),
- Illumination (MI 3102 only).

Large graphic matrix display with backlight offers easy to read results, indications, measurement parameters and messages. Operation is simple and clear – operator does not need any special training (except reading this instruction manual) to operate the instrument.

In order for operator to be familiar enough with measurements in general and typical applications it is advisable to read Metrel handbook *Measurements on electric installations in theory and practice*.

The instrument is equipped with all accessories necessary for comfortable testing. It is kept in a soft carrying bag together with all accessories.

2 Safety and operational considerations

2.1 Warnings and notes

In order to reach high level of operator's safety while carrying out various tests and measurements using the Eurotest instrument, as well as to keep the test equipment undamaged, it is necessary to consider the following general warnings:

- ❑  symbol on the instrument means »Read the Instruction manual with special care to safety operation«. The symbol requires an action!
- ❑ If the test equipment is used in a manner not specified in this user manual the protection provided by the equipment may be impaired!
- ❑ Read this user manual carefully, otherwise use of the instrument may be dangerous for the operator, for the instrument or for the equipment under test!
- ❑ Do not use the instrument and accessories if any damage is noticed!
- ❑ In case a fuse has blown follow the instructions in this manual to replace it!
- ❑ Consider all generally known precautions in order to avoid risk of electric shock while dealing with hazardous voltages!
- ❑ Do not use the instrument in supply systems with voltages higher than 550 V!
- ❑ Service intervention or adjustment procedure is allowed to be carried out only by a competent authorized person!
- ❑ Use only standard or optional test accessories supplied by your distributor!
- ❑ Consider that older and some of new optional test accessories compatible with this instrument meet only overvoltage category CAT III / 300 V!
It means that maximal allowed voltage between test terminals and ground is 300 V!
- ❑ Instrument contains rechargeable Ni-Cd or Ni-MH battery cells. The cells should only be replaced with the same type as defined on the battery placement label or in this manual. Do not use standard alkaline battery cells while power supply adapter is connected, otherwise they may explode!
- ❑ Hazardous voltages exist inside the instrument. Disconnect all test leads, remove the power supply cable and switch off the instrument before removing battery compartment cover.
- ❑ Do not connect any voltage source on CLAMP CURRENT input. It is intended only for connection of current clamp with current output. Maximal continuous input current is 30 mA!
- ❑ All normal safety precautions have to be taken in order to avoid risk of electric shock when working on electrical installations!

Warnings related to measurement functions

Insulation resistance

- ❑ Insulation resistance measurement should only be performed on de-energized objects!
- ❑ When measuring insulation resistance between installation conductors all loads must be disconnected and all switches closed!
- ❑ Do not touch the test object during the measurement or before it is fully discharged! Risk of electric shock!
- ❑ When an insulation resistance measurement has been performed on a capacitive object automatic discharge may not be done immediately! Warning message  and actual voltage is displayed during discharge, until voltage drops below 10 V.
- ❑ Do not connect test terminals to external voltage higher than 600 V (AC or DC) in order not to damage the test instrument!

Continuity functions

- ❑ Continuity measurements should only be performed on de-energized objects!
- ❑ Parallel impedances or transient currents may influence test results.

Testing PE terminal

- ❑ If phase voltage is detected on the tested PE terminal, stop all measurements immediately and take care the fault is eliminated before proceeding with any activity!

Notes related to measurement functions

General

- ❑ Indicator  means that the selected measurement cannot be performed because of irregular conditions on input terminals.
- ❑ Insulation resistance, continuity functions and earth resistance measurements shall be performed on de-energized objects.
- ❑ PASS / FAIL indication is enabled when limit is set. Apply appropriate limit value for evaluation of measurement results.
- ❑ In case that only two of three wires are connected to tested electrical installation, only voltage indication between these two wires is valid.

Insulation resistance

- ❑ In case of voltage higher than 10 V (AC or DC) between test terminals, the insulation resistance measurement will not be performed.

Continuity functions

- ❑ If voltage between test terminals is higher than 10 V the continuity functions cannot be performed.
- ❑ Before performing continuity measurement compensate test lead resistance if necessary. The compensation is performed in **Low Ω** function.

RCD functions

- ❑ Parameters set in one function are also kept for other RCD functions!
- ❑ The measurement of contact voltage does not normally trip an RCD. However, the trip limit may be exceeded as a result of leakage current flowing to the PE protective conductor or a capacitive connection between L and PE conductors.
- ❑ RCD trip-lock sub-function (function selector switch in **LOOP** position) takes longer to complete but offers much better accuracy of fault loop resistance result (in comparison with the R_L sub-result in **Contact voltage** function).
- ❑ RCD trip-out time and RCD trip-out current measurements will be performed only if contact voltage in pre-test at nominal differential current is lower than the set limit contact voltage!
- ❑ The autotest sequence (RCD AUTO function) stops when trip-out time is out of allowed time period.

Fault loop / RCD trip-lock impedance

- ❑ L and N test terminals are reversed automatically if L/L1 and N/L2 test leads (universal test cable) are connected in reversed way, or terminals of the tested wall plug are reversed, or plug commander is turned around (except in UK version).
- ❑ Low limit prospective short-circuit current value depends on fuse type, fuse current rating, fuse trip-out time and I_{PSC} scaling factor.
- ❑ Specified accuracy of tested parameters is valid only if mains voltage is stable during the measurement.
- ❑ Fault loop impedance measurement trips an RCD.
- ❑ The measurement of fault loop impedance using trip-lock function does not normally trip an RCD. However, the trip limit may be exceeded as a result of leakage current flowing to the PE protective conductor or a capacitive connection between L and PE conductors.

Line impedance

- ❑ Low limit prospective short-circuit current value depends on fuse type, fuse current rating, fuse trip-out time and I_{PSC} scaling factor.
- ❑ Specified accuracy of tested parameters is valid only if mains voltage is stable during the measurement.

Resistance to earth (MI 3102 only)

- ❑ If voltage between test terminals is higher than 30 V the resistance to earth measurement will not be performed.
- ❑ If a noise voltage higher than approx. 5 V is present between the H and E or S test terminals, “” (noise) warning symbol will be displayed, indicating that the test result may not be correct!

TRMS current (MI 3102 only)

- ❑ Use test clamp supplied by Metrel or other with similar characteristics (current output, 1000:1, appropriate measurement range, consider error of test clamp when evaluating measured results)!
- ❑ Current clamps Metrel A 1074 and A 1019 are suitable for use with MI 3102 EurotestXE instrument in range 0.2 A ÷ 200 A. Below 0.2 A they can be used as indicator only. They are not suitable for leakage current measurements.
- ❑ The only Metrel current clamps, suitable for leakage current measurements, are A 1018 (1000 A/1 A).

Illumination (MI 3102 only)

- ❑ For accurate measurement make sure that the milk glass bulb is lit without any shadows cast by hand, body or other unwanted objects.
- ❑ It is very important to know that the artificial light sources reach full power of operation after a period of time (see technical data for light sources) and should be therefore switched on for this period of time before the measurements are taken.

Testing PE terminal

- ❑ PE terminal can be tested in RCD, LOOP and LINE function selector switch positions only!
- ❑ For correct testing of PE terminal, the TEST key has to be touched for a few seconds.
- ❑ Make sure to stand on non-isolated floor while carrying out the test, otherwise test result may be wrong!

2.2 Batteries

- ❑  When battery cells have to be replaced or before opening battery/fuse compartment cover, disconnect any measuring accessory connected to the instrument and power off the instrument, hazardous voltage inside!
- ❑ Insert cells correctly, otherwise the instrument will not operate and the batteries could be discharged.
- ❑ If the instrument is not used for a long period of time remove all batteries from the battery compartment.
- ❑ Alkaline or rechargeable Ni-Cd or Ni-MH batteries (size AA) can be used. The operating hours are given for cells with a nominal capacity of 2100 mAh.
- ❑ Do not recharge alkaline battery cells!

2.3 Charging

The battery is charged whenever the power supply adapter is connected to the instrument. In-built protection circuits control the charging procedure and assure maximal battery lifetime. Power supply socket polarity is shown in figure 2.1.



Figure 2.1: Power supply socket polarity

Note:

- ❑ Use only power supply adapter delivered from manufacturer or distributor of the test equipment to avoid possible fire or electric shock!

2.4 Precautions on charging of new battery cells or cells unused for a longer period

Unpredictable chemical processes can occur during charging of new battery cells or cells that were unused for a longer period of time (more than 3 months). Ni-MH and Ni-Cd cells are affected to a various degree (sometimes called as memory effect). As a result the instrument operation time can be significantly reduced at the initial charging/discharging cycles.

Therefore it is recommended:

- ❑ To completely charge the battery (at least 14h with in-built charger).
- ❑ To completely discharge the battery (can be performed with normal work with the instrument).
- ❑ Repeating the charge/discharge cycle for at least two times (four cycles are recommended).

When using external intelligent battery chargers one complete discharging/charging cycle is performed automatically.

After performing this procedure a normal battery capacity is restored. The operation time of the instrument now meets the data in the technical specification.

Notes:

- ❑ The charger in the instrument is a pack cell charger. This means that the cells are connected in series during the charging so all of them must be in similar state (similarly charged, same type and age).
- ❑ Even one deteriorated battery cell (or just of an another type) can cause an improper charging of the entire battery pack (heating of the battery pack, significantly decreased operation time).
- ❑ If no improvement is achieved after performing several charging/discharging cycles the state individual battery cells should be determined (by comparing battery voltages, checking them in a cell charger, etc). It is very likely that only some of the cells are deteriorated.
- ❑ The effects described above should not be mixed with normal battery capacity decrease over time. All charging batteries lose some of their capacity when repeatedly charged/discharged. The actual decrease of capacity versus number of charging cycles depends on battery type and is provided in the technical specification from battery manufacturer.

2.5 Standards applied

The EurotestLITE, EurotestEASI and EurotestXE instruments are manufactured and tested in accordance with the following regulations:

Electromagnetic compatibility (EMC)

EN 61326 Electrical equipment for measurement, control and laboratory use – EMC requirements
Class B (Hand-held equipment used in controlled EM environments)

Safety (LVD)

EN 61010-1 Safety requirements for electrical equipment for measurement, control and laboratory use – Part 1: General requirements
EN 61010-031 Safety requirements for hand-held probe assemblies for electrical measurement and test
EN 61010-2-032 Safety requirements for electrical equipment for measurement, control, and laboratory use - Part 2-032: Particular requirements for hand-held and hand-manipulated current sensors for electrical test and measurement

Functionality

EN 61557 Electrical safety in low voltage distribution systems up to 1000 V_{AC} and 1500 V_{AC} – Equipment for testing, measuring or monitoring of protective measures
Part 1 General requirements
Part 2 Insulation resistance
Part 3 Loop resistance
Part 4 Resistance of earth connection and equipotential bonding
Part 5 Resistance to earth (MI 3102 only)
Part 6 Residual current devices (RCDs) in TT and TN systems
Part 7 Phase sequence
Part 10..... Combined measuring equipment
DIN 5032 Photometry
Part 7 Classification of illuminance meters and luminance meters

Other reference standards for testing RCDs

EN 61008 Residual current operated circuit-breakers without integral overcurrent protection for household and similar uses
EN 61009 Residual current operated circuit-breakers with integral overcurrent protection for household and similar uses
EN 60364-4-41 Electrical installations of buildings
Part 4-41 Protection for safety – protection against electric shock
BS 7671 IEE Wiring Regulations

Note about EN and IEC standards:

- Text of this manual contains references to European standards. All standards of EN 6XXXX (e.g. EN 61010) series are equivalent to IEC standards with the same number (e.g. IEC 61010) and differ only in amended parts required by European harmonization procedure.

3 Instrument description

3.1 Front panel

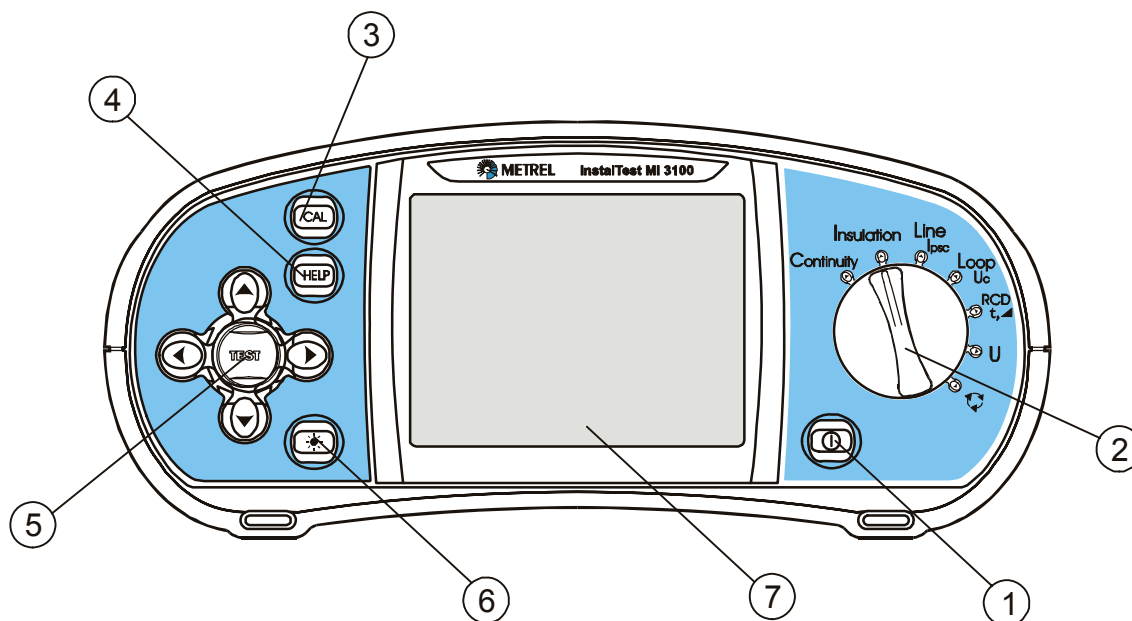

Figure 3.1: Front panel

Legend:

- 1 ON/OFF key, to switch on or off the instrument.
The instrument is automatically switched off 10 minutes after the last key was pressed or function switch rotated.
- 2 Function selector switch.
- 3 MI 3100: CAL key, to compensate test leads resistance in low-value resistance measurement.
MI 3002, MI 3102: MEM key, to access memory operations.
- 4 MI 3100: HELP key, to access help menus.
MI 3002, MI 3102: HELP/CAL key, to access help menus. CAL function is enabled in low-value resistance measurement to compensate test leads resistance.
- 5 Jogger keypad with cursors and TEST keys.
The TEST key also acts as the PE touching electrode.
- 6 BACKLIGHT and CONTRAST key, to change backlight level and contrast.
High level backlight is automatically shut off 20 seconds after the last strike of any key or function switch rotation in order to extend service life of the battery.
- 7 128 × 64 dots matrix display with backlight.

3.2 Connector panel

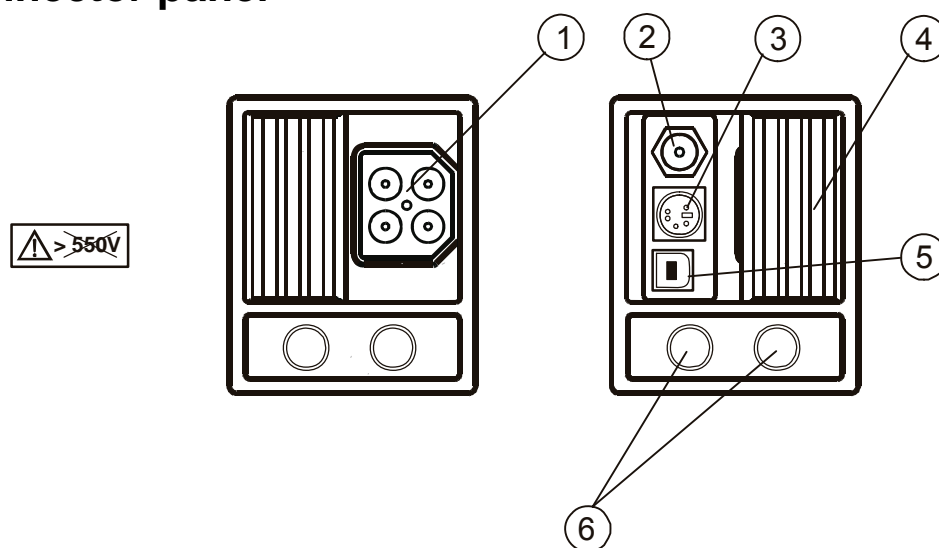

Figure 3.2: Connector panel

Legend:

1 Test connector.

Warning! Maximal allowed voltage between test terminals and ground is 600 V! Maximal allowed voltage between test terminals is 550 V!

MI 3102 only: In resistance to earth function test connector terminals are used as follows:

- L/L1 black test lead is used for the auxiliary earth electrode (H).
- N/L2 blue test lead is used for the earth electrode (E).
- PE/L3 green test lead is used for the probe (S).

2 Power supply socket.

3 RS 232 connector (MI 3002 and MI 3102).

4 Protection connector cover.

5 USB connector (MI 3002 and MI 3102).

6 CLAMP CURRENT input (MI 3102 only).

Warning! Do not connect any voltage source on this input. It is intended for connection of current clamp with current output only. Maximal continuous input current is 30 mA!

3.3 Back panel

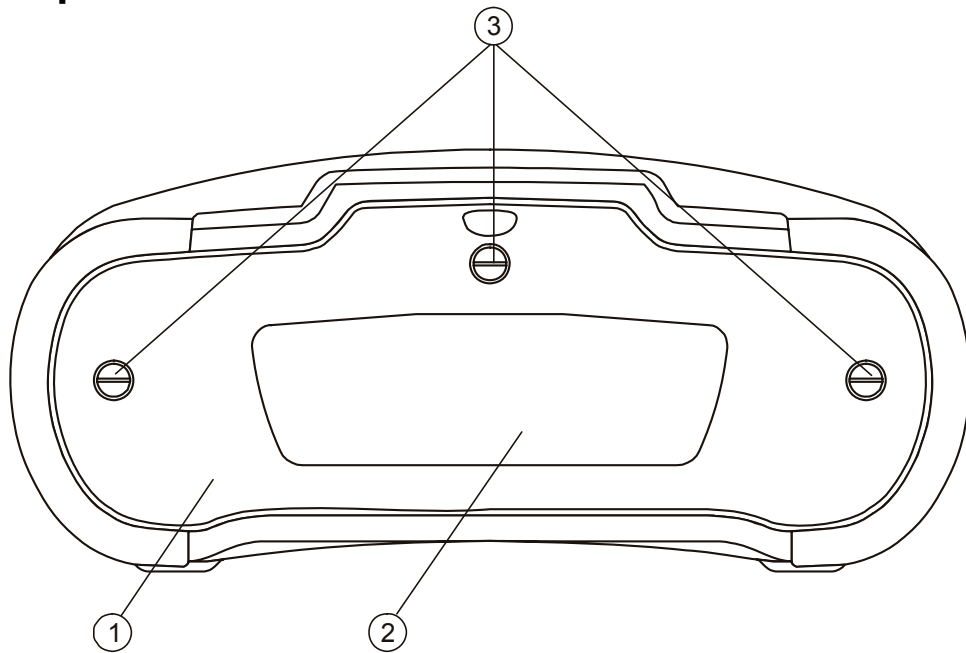

Figure 3.3: Back panel

Legend:

- 1 Battery/fuse compartment cover.
- 2 Information label.
- 3 Fixing screws for battery/fuse compartment cover.

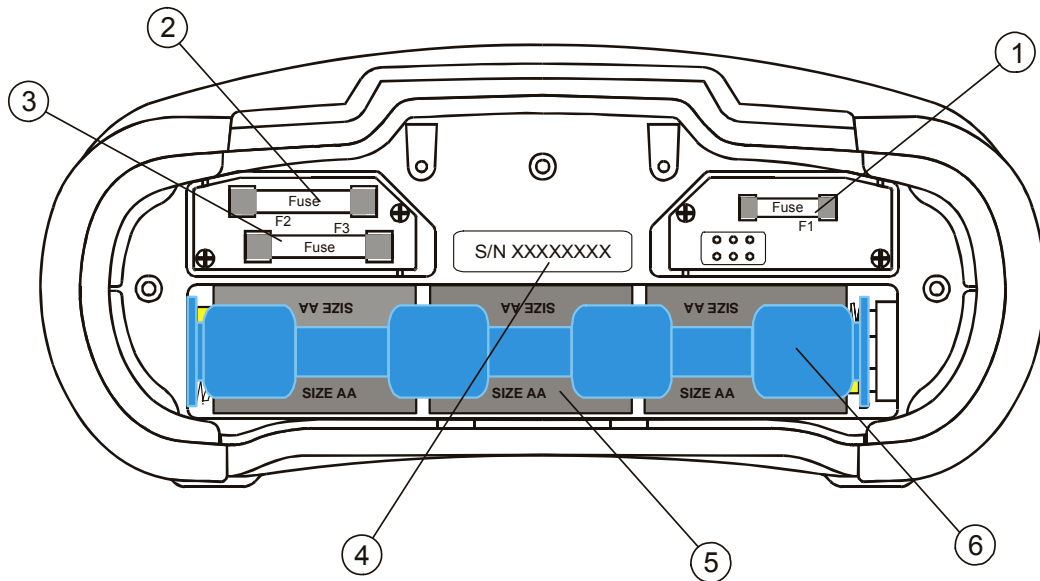

Figure 3.4.: Battery and fuse compartment

Legend:

- 1 Fuse F1.
- 2 Fuse F2.
- 3 Fuse F3.
- 4 Serial number label.
- 5 Battery cells (size AA).
- 6 Battery holder.

3.4 Bottom view

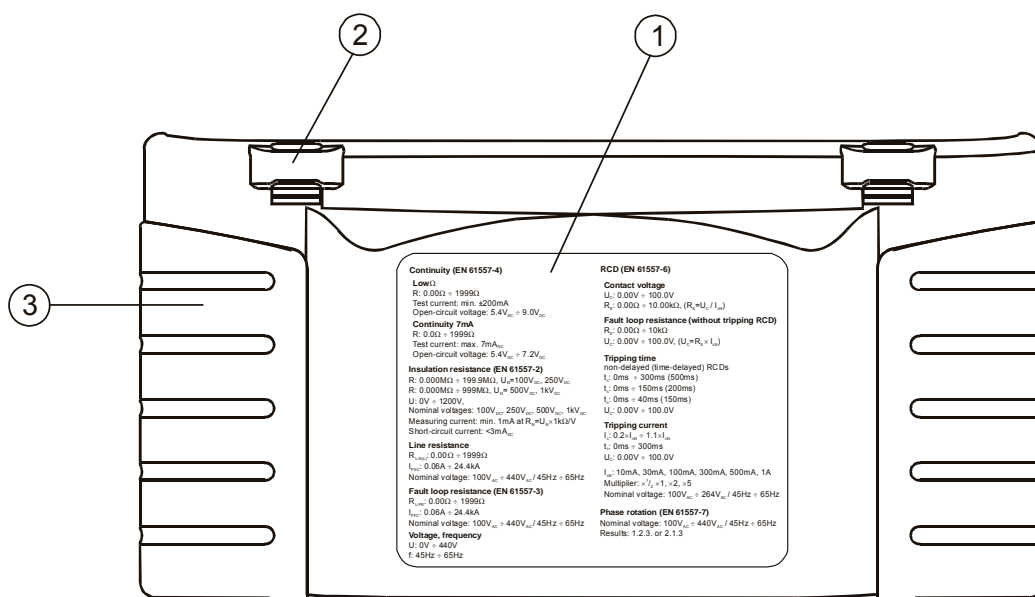

Figure 3.5: Bottom view

Legend:

- 1 Information label.
- 2 Neck belt openings.
- 3 Handling side covers.

3.5 Carrying the instrument

With the neck carrying belt supplied in standard set, various possibilities of carrying the instrument are available. Operator can choose appropriate one on basis of his / her operation, see the following examples:

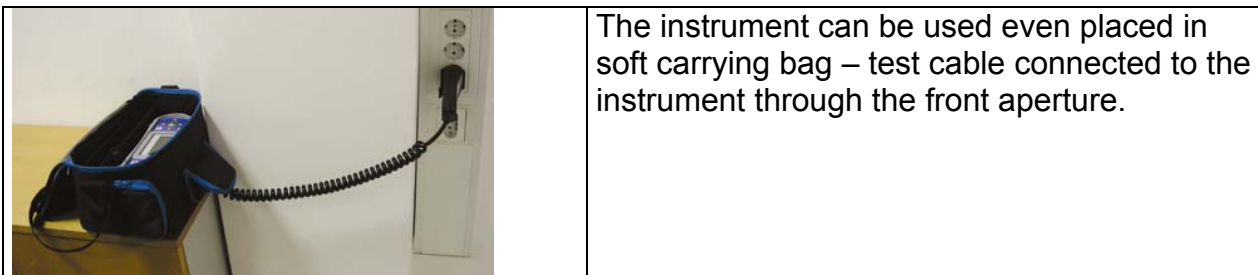

3.6 Instrument set and accessories

Instrument	EurotestEASI – MI 3100	Eurotest – MI 3002	EurotestXE – MI 3102
	Soft carrying bag Soft carrying neck belt Soft carrying back belt	Soft carrying bag Soft carrying neck belt Soft carrying back belt	Soft carrying bag Soft carrying neck belt Soft carrying back belt
<i>Measuring accessories</i> ^{*)}	Universal test cable (3 × 1.5 m) Tip commander with two function keys Schuko plug cable Test tip (blue) Test tip (black) Test tip (green) 3 alligator clips (black)	Universal test cable (3 × 1.5 m) Tip commander with two function keys Schuko plug cable Test tip (blue) Test tip (black) Test tip (green) 3 alligator clips (black)	Universal test cable (3 × 1.5 m) Tip commander with two function keys Schuko plug cable Test tip (blue) Test tip (black) Test tip (green) 3 alligator clips (black) Earth test set – 20 m: Test lead (black, 20 m) Test lead (blue, 4.5 m) Test lead (green, 20 m)
<i>Documentation</i>	Short instruction manual Product verification data Warranty declaration Declaration of conformity	Short instruction manual Product verification data Warranty declaration Declaration of conformity	Short instruction manual Product verification data Warranty declaration Declaration of conformity
<i>Battery</i>	6 Ni-MH rechargeable cells Power supply adapter	6 Ni-MH rechargeable cells Power supply adapter	6 Ni-MH rechargeable cells Power supply adapter
<i>Cables</i>		RS232 cable USB cable	RS232 cable USB cable
<i>CD-ROM</i>	Instruction manual Short instruction manual Measurement on electric installations in theory and practice	Instruction manual Short instruction manual Measurement on electric installations in theory and practice EuroLinkXE PC software	Instruction manual Short instruction manual Measurement on electric installations in theory and practice EuroLinkXE PC software
<i>Optional accessories</i> ^{*)}	Plug commander with two function keys Three-phase cable Three-phase adapter Test lead (black, 4 m) Test lead (black, 20 m) Test lead (black, 50 m) Fast 12 cells charger (C and AA sizes) Fast 6 cells charger (AA size)	Plug commander with two function keys Three-phase cable Three-phase adapter Test lead (black, 4 m) Test lead (black, 20 m) Test lead (black, 50 m) Fast 12 cells charger (C and AA sizes) Fast 6 cells charger (AA size)	Plug commander with two function keys Three-phase cable Three-phase adapter Test lead (black, 50 m) Low current range clamp Mini current clamp Connection cable for mini current LUXmeter probe, type B LUXmeter probe, type C Fast 12 cells charger (C and AA sizes) Fast 6 cells charger (AA size)

^{*)}Please, see the attached sheet to compare received set of accessories with listed one. See also the attached sheet for a list of optional accessories that are available on request from your distributor.

4 Instrument operation

4.1 Meaning of symbols and messages on the instrument display

The instrument display is divided into four sections:

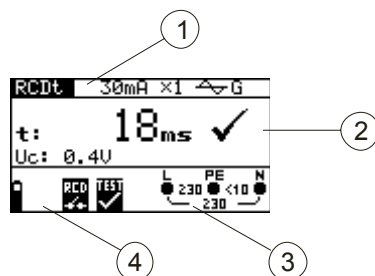
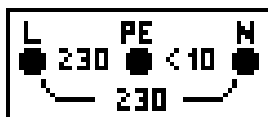

Figure 4.1: Display outlook

Legend:

- 1 Function and parameter line.
In the top display line the measuring function/sub-function and parameters are displayed.
- 2 Result field.
In this field the main result and sub-results together with the PASS/FAIL/ABORT status are displayed.
- 3 Online voltage and output monitor.
- 4 Message field.

4.1.1 The online voltage and output terminal monitor



Online voltage is displayed together with test terminal indication. All three test terminals are used for selected measurement.

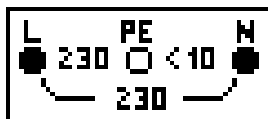

Online voltage is displayed together with test terminal indication. L and N test terminals are used for selected measurement.

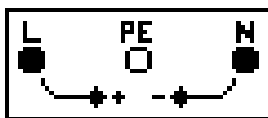

Polarity of test voltage applied to the output terminals, L and N.



Unknown supply system.



L – N polarity changed.



Frequency out of range.

4.1.2 Message field – battery status



Battery power indication.



Low battery indication. Battery pack is too weak to guarantee correct result. Replace the batteries.



Recharging is running (if power supply adapter is connected).

4.1.3 Message field – measurement warnings/messages

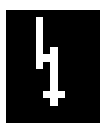

Warning! High voltage is applied to the test terminals.

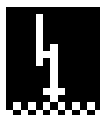

Warning! Phase voltage on the PE terminal! Stop all the measurements immediately and eliminate the fault before proceeding with any activity!



Measurement is running. Consider any displayed warnings!



Measurement can be performed after pressing the TEST key. Consider any displayed warning after starting the measurement!



Measurement prohibited. Consider any displayed warnings and check online voltage/terminal monitor!



Test leads resistance in low-value resistance measurement is compensated.



RCD tripped during the measurement. The trip limit may be exceeded as a result of leakage current flowing to the PE protective conductor or capacitive connection between L and PE conductors.



RCD not tripped during the measurement.

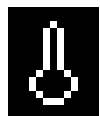

Instrument overheated. Temperature of internal components in the instrument reached top limit. Measurement is prohibited until the temperature is lower than that limit.



Battery capacity is too low to guarantee correct result. Replace the batteries.



Fuse F1 (continuity circuit) blown or not inserted.



Single fault condition in IT system.



Noise voltage is present between H and E or S test terminals.



Resistance of auxiliary earth electrode is higher than $100 \times R_E$. Check the auxiliary earth electrode.



Probe resistance is higher than $100 \times R_E$. Check the probe.



Resistances of auxiliary earth electrode and probe are higher than $100 \times R_E$. Check all probes.

4.1.4 Result field



Measurement passed.



Measurement failed.



Measurement is aborted. Check the conditions at the input terminal.

4.1.5 Other messages

Hard Reset

Instrument settings and measurement parameters/limits are set to initial (factory) values. For more information refer to chapter 4.5.5. *Recalling original settings.*

No probe

LUXmeter probe is turned off or disconnected from the EurotestXE instrument. Connect probe to the instrument using RS232 connector and turn it on.

First measurement

First stored measurement results are displayed.

Last measurement

Last stored measurement results are displayed.

Memory full

All memory locations are occupied.

Already saved

Measurement results already saved.

CHECK SUM ERROR

Memory contents damaged. Contact your distributor or manufacturer for further information.

4.1.6 Sound warnings

The shortest sound	Pressed key deactivated. Sub-function is not available.
Short sound	Pressed key activated. Measurement has been started after pressing the TEST key. Consider any displayed warnings during measurement.
Long sound	Measurement is prohibited. Consider any displayed warnings and check online voltage/terminal monitor!
Periodic sound	Warning! Phase voltage on the PE terminal! Stop all the measurements immediately and eliminate the fault before proceeding with any activity!

4.1.7 Function and parameter line



Figure 4.2: Function selector switch and belonging parameter line

Legend:

- 1.....Main function name.
- 2.....Function or sub-function name.
- 3.....Measuring parameters and limit values.

4.2 Selecting measurement function/subfunction

The following measurements can be selected with the function selector switch:

- Voltage and frequency,
- Insulation resistance,
- Low-value resistance,
- RCD testing,
- Fault loop impedance,
- Line impedance,
- Phase sequence,
- Resistance to earth (MI 3102 only),
- TRMS current (MI 3102 only),
- Illumination (MI 3102 only).

The function/sub-function name is highlighted on the display by default.
Sub-function can be selected by using ▲ and ▼ keys in function/parameter line.

4.3 Setting measurement parameters and limits

By using ◀ and ▶ keys select the parameter/limit value you want to edit. By using ▲ and ▼ keys the selected parameter can be set.

Once the measurement parameters are set the settings are kept until new changes are made or the original settings are recalled.

4.4 Help menu

Help menus are available in all functions. The **Help** menu contains schematic diagrams for illustration how to properly connect the instrument to electric installation. After selecting the measurement you want to perform, press the HELP key in order to view the belonging **Help** menu.

Press the HELP key again to see further **Help** screens if available or to return to the function menu.

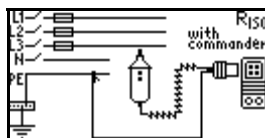

Figure 4.3: Example of help menu

4.5 Setup menu

In the **Setup** menu the following actions can be taken:

- ❑ Supply system selection,
- ❑ Prospective short/fault current scaling factor adjustment,
- ❑ Language selection,
- ❑ Communication port settings (MI 3002 and MI 3102)
- ❑ Support for remote comamnders.

To enter the **Setup** menu press the BACKLIGHT key and rotate function selector switch in any direction at the same time.

Rotate function selector switch again to leave **Setup** menu or setup sub-menus.

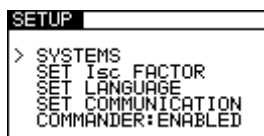

Figure 4.4: Setup menu

4.5.1 Supply system setup

The instrument enables tests and measurements in the following supply systems:

- TN (TT) system,
- IT system,
- Reduced low voltage system (2×55 V),
- Reduced low voltage system (3×63 V).

Select SYSTEMS in the **Setup** menu by using \blacktriangle and \blacktriangledown keys and press the TEST key to enter the **Supply system** setup menu.

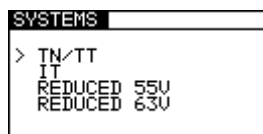

Figure 4.5: Supply systems selecting menu

By using \blacktriangle and \blacktriangledown keys select supply system and press the TEST key to accept the setting.

4.5.2 Prospective short/fault current scaling factor adjustment

Select SET I_{SC} FACTOR in **Setup** menu by using \blacktriangle and \blacktriangledown keys and press the TEST key to enter the **Prospective short/fault current scaling factor** adjustment menu.

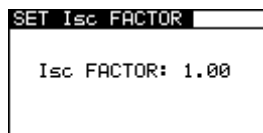

Figure 4.6: Scaling factor adjustment menu

Use \blacktriangle and \blacktriangledown keys to adjust the scaling factor. Press the TEST key to accept the new setting.

More information about the prospective short/fault current scaling factor can be found in chapters 5.4 and 5.5.

Note:

- In UK version, impedance scaling factor Z is used instead of prospective short/fault scaling factor I_{sc}.

4.5.3 Language selection

Select SET LANGUAGE in **Setup** menu by using the \blacktriangle and \blacktriangledown keys and press the TEST key to enter the **Language** selecting menu.

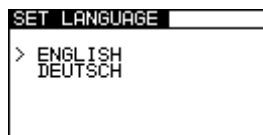

Figure 4.7: Language selecting menu

By using ▲ and ▼ keys select language you want to use. Press The TEST key to accept the new setting.

4.5.4 Communication port selection (MI 3002 and MI 3102)

Select SET COMMUNICATION PORT in **Setup** menu by using ▲ and ▼ keys and press the TEST key to enter the **Communication** menu.

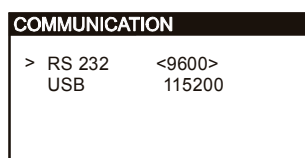

Figure 4.8: Communication menu

By using ▲ and ▼ keys select communication port you want to use. If RS232 communication port is selected, use ◀ and ▶ keys to select baud rate. USB port has a baud rate set to 115200 bps. Press the TEST key to accept the new setting.

Note:

- Only one port can be active at one time.

4.5.5 Plug / Tip commander support

Select COMMANDER in **Setup** menu by using ▲ and ▼ keys and press the TEST key to switch on / off the support for remote commanders.

If **disable** is selected then keys on Plug / Tip commander are disabled (except backlight key). The selected test can be started (or results can be saved) using instrument keys only,

If **enable** option is selected, then keys on Plug / Tip commander are activated.

Note:

- This option is intended to disable the commander's remote keys. In the case of high EM interfering noise the operation of the commander's key can be irregular.

4.5.6 Recalling original settings

The following parameters and settings can be set to initial (factory) values:

- Test parameters and limit values,
- Contrast,

- ❑ Prospective short/fault current scaling factor,
- ❑ Supply system,
- ❑ Communication port (MI 3002 and MI 3102)
- ❑ Support for remote commanders.

In order to recall original setting press and hold ➤ key and switch on the instrument.

»Hard reset« message will be displayed for a while.

Instrument settings, measurement parameters and limits are set to their initial values as follows:

Instrument settings	Default value
Contrast	50 %
Prospective short/fault current scaling factor (except in UK version)	1.00
Impedance scaling factor Z (UK version only)	0.8
Supply system	TN/TT
Communication	RS232, 9600 bps
Commander	Enabled

Function Sub-function	Parameter / limit value
CONTINUITY	Selected function: R LOW Ω
R LOW Ω	High limit resistance value: 2.0 Ω
Continuity	High limit resistance value: 20.0 Ω
INSULATION	Nominal test voltage: 500 V Low limit resistance value: 1 M Ω
LINE	Fuse type: none selected (*F) Fuse current rating: none selected (*A) Fuse tripping current: none selected (*ms)
LOOP Z LOOP Zs (rcd)	Fuse type: none selected (*F) Fuse current rating: none selected (*A) Fuse tripping current: none selected (*ms)
RCD	Selected function: RCD Uc
Contact voltage – RCD Uc Trip-out time – RCD t Trip-out current – RCD I _{th} Autotest – RCD AUTO	Nominal differential current: I _{ΔN} =30 mA RCD type and test current starting polarity: Δ ∇ G Limit contact voltage: 50 V Nominal differential current multiplier: $\times 1$
RESISTANCE TO EARTH (MI 3102 only)	High limit resistance value: 50 Ω
ILLUMINATION (MI 3102 only)	Low limit illumination value: 300 lux
TRMS CURRENT (MI 3102 only)	Current limit: 4.5 mA

4.6 Display contrast adjustment

When low-level backlight is activated press and hold BACKLIGHT key until the **Display contrast** adjustment menu is displayed.



Figure 4.9: Contrast adjustment menu

Use \blacktriangle and \blacktriangledown keys to adjust the contrast level. Press the TEST key to accept the new setting.

5 Measurements

5.1 Insulation resistance

Insulation resistance measurement is performed in order to assure safety against electric shock. Using this measurement the following items can be determined:

- Insulation resistance between installation conductors,
- Insulation resistance of non-conductive rooms (walls and floors),
- Insulation resistance of ground cables,
- Resistance of semi-conductive (antistatic) floors.

For additional general information concerning insulation resistance measurement refer to the Metrel handbook *Measurements on electric installations in theory and practice*.

How to perform insulation resistance measurement

Step 1 Select **Insulation** function with the function selector switch. The following menu is displayed:

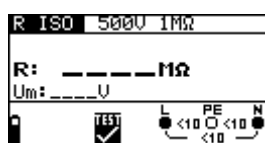

Figure 5.1: Insulation resistance measurement menu

Connect test cable to the Eurotest instrument.

Step 2 Set the following measuring parameter and limit values:

- Nominal test voltage,
- Low limit resistance value.

Step 3 Connect test cable to the item under test. Follow the connection diagram shown in figure 5.2 to perform insulation resistance measurement. Use the **Help** function if necessary.

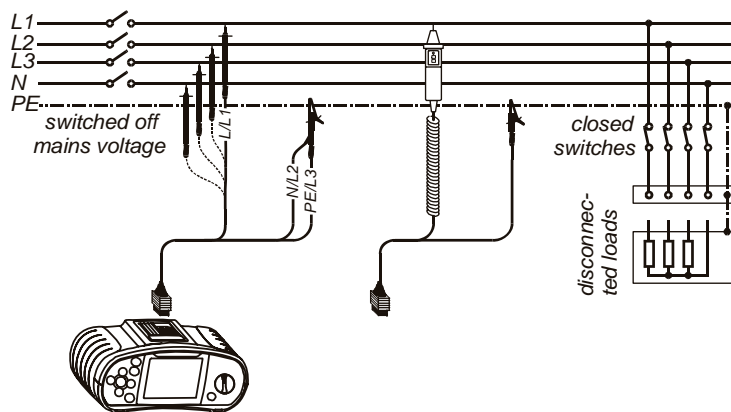

Figure 5.2: Connection of universal test cable and tip commander

Step 4 Check the displayed warnings and online voltage/terminal monitor before starting the measurement. If OK, press and hold the TEST key until result is stabilised. Actual measured results are shown on the display during measurement.

After the TEST key is released the last measured results are displayed, together with the PASS/FAIL indication (if applicable).

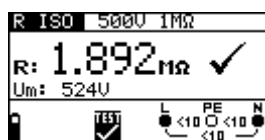



Figure 5.3: Example of insulation resistance measurement results

Displayed results:

RInsulation resistance,
UmInstrument test voltage.

Save displayed results for documentation purposes. Refer to chapter 6.1. *Saving results* (MI 3002 and MI 3102).

Warnings:

- ❑ Insulation resistance measurement should only be performed on de-energized objects!
- ❑ When measuring insulation resistance between installation conductors all loads must be disconnected and all switches closed!
- ❑ Do not touch the test object during the measurement or before it is fully discharged! Risk of electric shock!
- ❑ When an insulation resistance measurement has been performed on a capacitive object automatic discharge may not be done immediately! Warning message  and actual voltage is displayed during discharge, until voltage drops below 10 V.
- ❑ Do not connect test terminals to external voltage higher than 600 V (AC or DC) in order not to damage the test instrument!

Note:

- ❑ In case of voltage higher than 10 V (AC or DC) between test terminals, the insulation resistance measurement will not be performed.

5.2 Continuity

Two **Continuity** sub-functions are available:

- Low Ω resistance,
- Continuity.

5.2.1 Low Ω resistance

This test is used to ensure electric safety and correct connection of all protective conductors, earth conductors or bonding conductors. The measurement of Low Ω resistance is performed with automatic pole reversal of the test voltage and the test current of more than 200 mA. This measurement completely complies with EN61557-4 regulations.

How to perform Low Ω resistance measurement

Step 1 Select **Continuity** function with the function selector switch first. Use the $\blacktriangle/\blacktriangledown$ keys to select **R LOW Ω** function. The following menu is displayed:

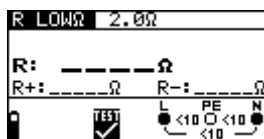

Figure 5.4: Low Ω resistance measurement menu

Connect test cable to the Eurotest instrument.

Step 2 Set the following limit value:

- High limit resistance value.

Step 3 Before performing Low Ω measurement compensate test leads resistance as follows:

1. Short test leads first as shown in figure 5.11.

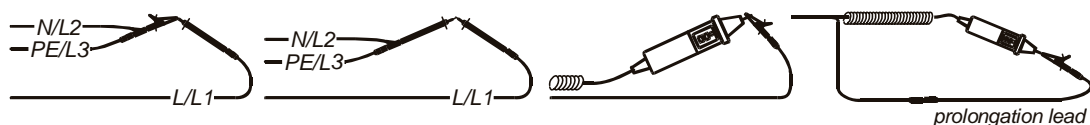

Figure 5.5: Shorted test leads

2. Press the TEST key in order to perform regular measurement. Result close to 0.00 Ω is displayed.

3. Press the CAL key. After performing test leads compensation compensated test leads indicator is displayed.
4. In order to annul potential compensation follow the procedure described in this step with open test leads. After annulling compensation, the compensation indicator disappears.

Compensation performed in this function is also considered in the **Continuity** measurement.

Step 4 Connect test cable to the item under test. Follow the connection diagram shown in figures 5.12 and 5.13 to perform **Low Ω resistance** measurement. Use the **Help** function if necessary.

MPEC....Main Potential Equilizing Collector
PCC....Protection Conductor Collector

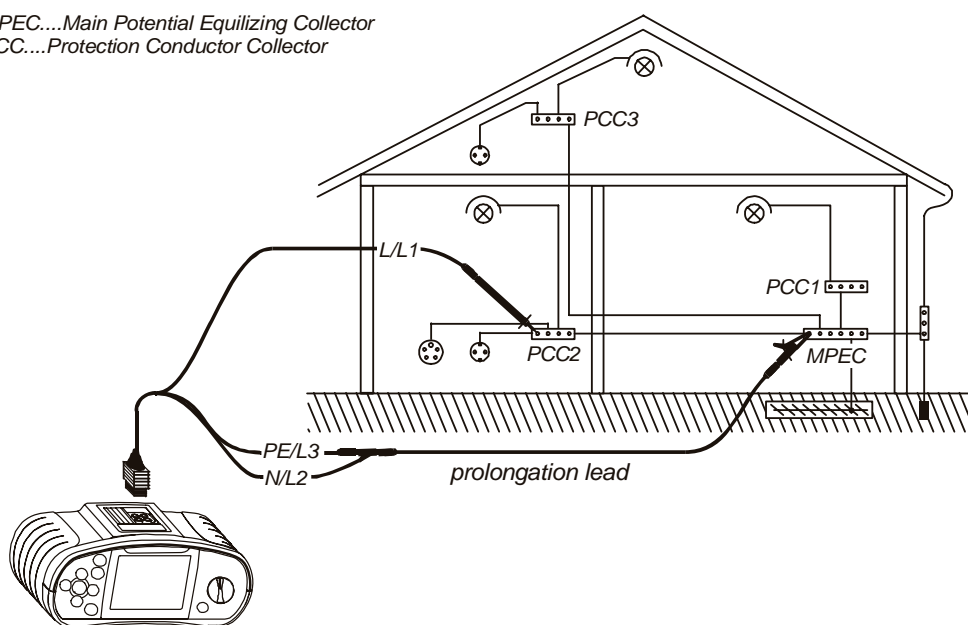

Figure 5.6: Connection of universal test cable and optional probe test lead

MPEC....Main Potential Equilizing Collector
PCC....Protection Conductor Collector

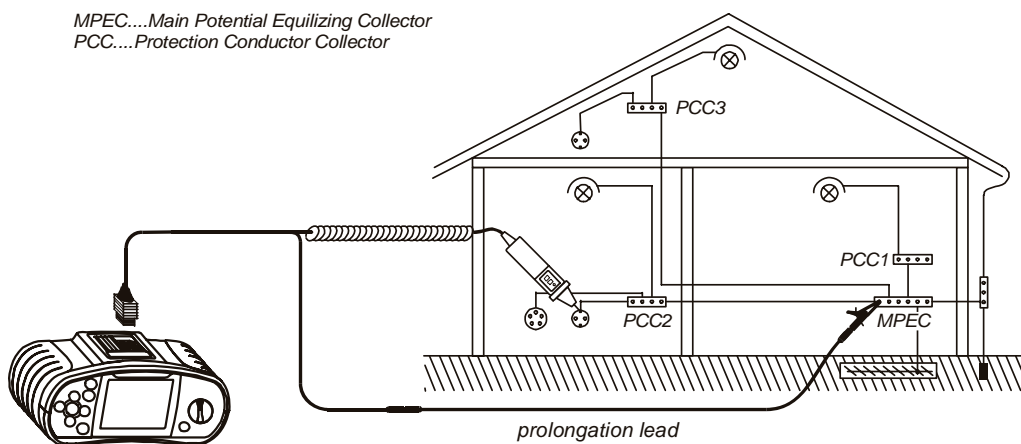

Figure 5.7: Connection of tip commander and optional probe test lead

- Step 5** Check the displayed warnings and online voltage/terminal monitor before starting measurement. If OK, press the TEST key. After performing the measurement results appear on the display together with the PASS/FAIL indication (if applicable).



Figure 5.8: Example of Low Ω resistance measurement results

Displayed results:

- R.....Main Low Ω resistance result (average of R+ and R- results),
- R+.....Low Ω resistance sub-result with positive voltage at L terminal,
- R-.....Low Ω resistance sub-result with positive voltage at N terminal.

Save displayed results for documentation purposes. Refer to chapter 6.1. *Saving results* (MI 3002 and MI 3102).

Warnings:

- Low-value resistance measurement should only be performed on de-energized objects!
- Parallel impedances or transient currents may influence test results.

Note:

- If voltage between test terminals is higher than 10 V the R LOW Ω measurement will not be performed.

5.2.2 Continuity

Continuous low-value resistance measurement can be performed without pole reversal of the test voltage and a lower test current (few mA). In general function serves as an ordinary Ω -meter with low-test current. Function can also be used to test inductive components.

For additional information concerning continuity measurement refer to the Metrel handbook *Measurements on electric installations in theory and practice*.

How to perform Continuity measurement

Step 1 Select **Continuity** function with the function selector switch first. Use the $\blacktriangle/\blacktriangledown$ keys to select **Continuity** function. The following menu is displayed:

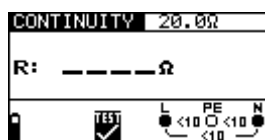

Figure 5.9: Continuity measurement menu

Connect test cable to the Eurotest instrument.

Step 2 Set the following limit value:

- High limit resistance value.

Step 3 Connect test cable to the item under test. Follow the connection diagram shown in figures 5.16 and 5.17 to perform **Continuity** measurement. Use the **Help** function if necessary.

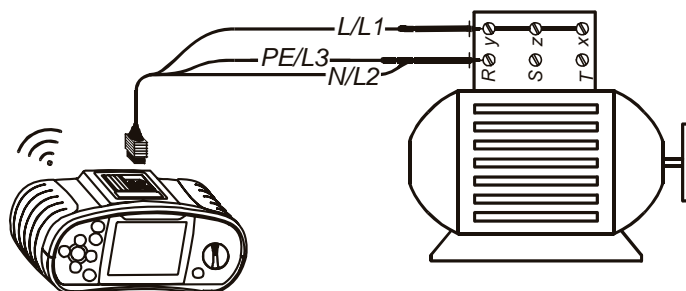

Figure 5.10: Connection of universal test cable

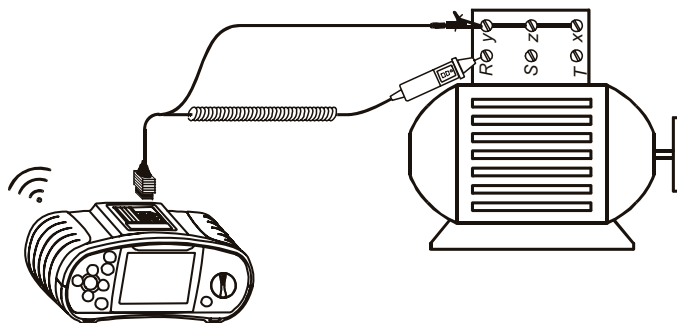

Figure 5.11: Connection of tip commander

- Step 4** Check the displayed warnings and online voltage/terminal monitor before starting measurement. If OK, press the TEST key to start the measurement. Actual measuring result with PASS/FAIL indication (if applicable) is shown on the display during measurement. To stop measurement at any time press the TEST key again. The last measured result is displayed, together with the PASS/FAIL indication (if applicable).

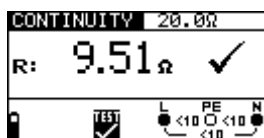

Figure 5.12: Example of Continuity measurement result

Displayed result:

R.....Continuity resistance result.

Save displayed results for documentation purposes. Refer to chapter 6.1. *Saving results* (MI 3002 and MI 3102).

Warning:

- ❑ Continuity measurement should only be performed on de-energized objects!

Notes:

- ❑ If voltage between test terminals is higher than 10 V the continuity measurement cannot be performed.
- ❑ Before performing continuity measurement compensate test lead resistance if necessary. The compensation is performed in **LowΩ** function.

5.3 Testing RCDs

When testing RCDs, the following sub-functions can be performed:

- ❑ Contact voltage measurement,
- ❑ Trip-out time measurement,
- ❑ Trip-out current measurement,
- ❑ RCD autotest.

In general the following parameters and limits can be set when testing RCDs:

- ❑ Limit contact voltage,
- ❑ Nominal differential RCD trip-out current,
- ❑ Multiplier of nominal differential RCD trip-out current,
- ❑ RCD type,
- ❑ Test current starting polarity.

5.3.1 Limit contact voltage

Safety contact voltage is limited to 50 V_{AC} for standard domestic area. In special environments (hospitals, wet places, etc.) contact voltages up to 25 V_{AC} are permitted. Limit contact voltage can be set in **Contact voltage** function only!

5.3.2 Nominal differential trip-out current



Nominal differential current is the rated trip-out current of an RCD. The following RCD current ratings can be set: 10 mA, 30 mA, 100 mA, 300 mA, 500 mA and 1000 mA.

5.3.3 Multiplier of nominal residual current

Selected nominal differential current can be multiplied by ½, 1, 2 or 5.

5.3.4 RCD type and test current starting polarity

Eurotest instrument enables testing of general (non-delayed) and selective (time-delayed, marked with ) RCDs, which are suited for:

- ❑ Alternating residual current (AC type, marked with ) symbol),
- ❑ Pulsating DC residual current (A type, marked with ) symbol).

Test current starting polarity can be started with the positive half-wave at 0° or with the negative half-wave at 180°.

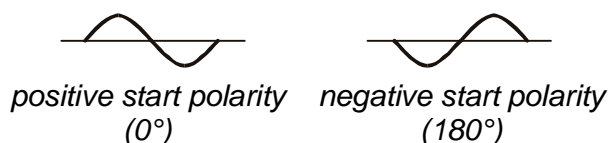

Figure 5.13: Test current started with the positive or negative half-wave

5.3.5 Testing selective (time-delayed) RCDs

Selective RCDs demonstrate delayed response characteristics. Trip-out performance is influenced due to the pre-loading during measurement of contact voltage. In order to eliminate pre-loading a time delay of 30 s is inserted before performing trip-out test.

5.3.6 Contact voltage

Leakage current flowing to the PE terminal causes a voltage drop across earth resistance, which is called contact voltage. This voltage is present on all accessible parts connected to the PE terminal and should be lower than the safety limit voltage. The parameter contact voltage is measured without tripping-out the RCD. R_L is a fault loop resistance and is calculated as follows:

$$R_L = \frac{U_C}{I_{\Delta N}}$$

Displayed contact voltage relates to the rated nominal differential current of the RCD and is multiplied by a safety factor. See the table 5.1 for detailed contact voltage calculation.





RCD type	Contact voltage U_C
	$U_C \propto 1.05 \times I_{\Delta N}$
	$U_C \propto 1.05 \times 2 \times I_{\Delta N}$
	$U_C \propto 1.05 \times \sqrt{2} \times I_{\Delta N}$
	$U_C \propto 1.05 \times 2 \times \sqrt{2} \times I_{\Delta N}$

Table 5.1: Relationship between U_C and $I_{\Delta N}$

For additional general information concerning contact voltage measurement refer to the Metrel handbook *Measurements on electric installations in theory and practice*.

How to perform contact voltage measurement

Step 1 Select **RCD** function with the function selector switch first. Use the $\blacktriangle/\blacktriangledown$ keys to select **Contact voltage** function. The following menu is displayed:

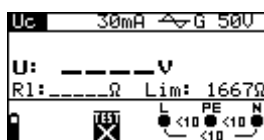

Figure 5.14: Contact voltage measurement menu

Connect test cable to the Eurotest instrument.

Step 2 Set the following measuring parameters and limit values:

- Nominal residual current,
- RCD type,
- Limit contact voltage.

Step 3 Follow the connection diagram shown in figure 5.21 to perform contact voltage measurement. Use the **Help** function if necessary.

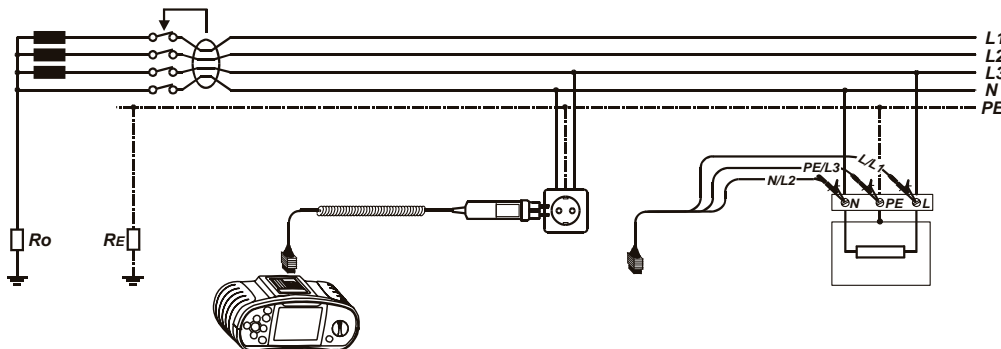

Figure 5.15: Connection of plug test cable or universal test cable

Step 4 Check the displayed warnings and online voltage/terminal monitor before starting the measurement. If OK, press the TEST key. After performing the measurement results with PASS/FAIL indication appear on the display.



Figure 5.16: Example of contact voltage measurement results

Displayed results:

UContact voltage.

RIFault loop resistance.

LimLimit earth fault loop resistance value according to BS 7671.

Save displayed results for documentation purposes. Refer to chapter 6.1. *Saving results* (MI 3002 and MI 3102).

Notes:

- Parameters set in this function are also kept for other RCD functions!
- The measurement of contact voltage does not normally trip an RCD. However, the trip limit may be exceeded as a result of leakage current flowing to the PE protective conductor or a capacitive connection between L and PE conductors.
- RCD trip-lock sub-function (function selector switch in **LOOP** position) takes longer to complete but offers much better accuracy of fault loop resistance result (in comparison with the R_L sub-result in **Contact voltage** function).

5.3.7 Trip-out time

Trip-out time measurement is used to verify the effectiveness of the RCD. This is achieved by a test simulating an appropriate fault condition. Trip-out times vary between standards and are listed below.

Trip-out times according to EN 61008 / EN 61009:

	$\frac{1}{2} \times I_{\Delta N}^{*)}$	$I_{\Delta N}$	$2 \times I_{\Delta N}$	$5 \times I_{\Delta N}$
General (non-delayed) RCDs	$t_{\Delta} > 300 \text{ ms}$	$t_{\Delta} < 300 \text{ ms}$	$t_{\Delta} < 150 \text{ ms}$	$t_{\Delta} < 40 \text{ ms}$
Selective (time-delayed) RCDs	$t_{\Delta} > 500 \text{ ms}$	$130 \text{ ms} < t_{\Delta} < 500 \text{ ms}$	$60 \text{ ms} < t_{\Delta} < 200 \text{ ms}$	$50 \text{ ms} < t_{\Delta} < 150 \text{ ms}$

Trip-out times according to IEC 60364-4-41:

	$\frac{1}{2} \times I_{\Delta N}^{*)}$	$I_{\Delta N}$	$2 \times I_{\Delta N}$	$5 \times I_{\Delta N}$
General (non-delayed) RCDs	$t_{\Delta} > 999 \text{ ms}$	$t_{\Delta} < 999 \text{ ms}$	$t_{\Delta} < 150 \text{ ms}$	$t_{\Delta} < 40 \text{ ms}$
Selective (time-delayed) RCDs	$t_{\Delta} > 999 \text{ ms}$	$130 \text{ ms} < t_{\Delta} < 999 \text{ ms}$	$60 \text{ ms} < t_{\Delta} < 200 \text{ ms}$	$50 \text{ ms} < t_{\Delta} < 150 \text{ ms}$

Trip-out times according to BS 7671:

	$\frac{1}{2} \times I_{\Delta N}^{*)}$	$I_{\Delta N}$	$2 \times I_{\Delta N}$	$5 \times I_{\Delta N}$
General (non-delayed) RCDs	$t_{\Delta} > 1999 \text{ ms}$	$t_{\Delta} < 300 \text{ ms}$	$t_{\Delta} < 150 \text{ ms}$	$t_{\Delta} < 40 \text{ ms}$
Selective (time-delayed) RCDs	$t_{\Delta} > 1999 \text{ ms}$	$130 \text{ ms} < t_{\Delta} < 500 \text{ ms}$	$60 \text{ ms} < t_{\Delta} < 200 \text{ ms}$	$50 \text{ ms} < t_{\Delta} < 150 \text{ ms}$

^{*)} Test current of $\frac{1}{2} \times I_{\Delta N}$ cannot cause trip-out of the RCDs.

For additional general information concerning trip-out time measurement refer to the Metrel handbook *Measurements on electric installations in theory and practice*.

How to perform trip-out time measurement

Step 1 Select **RCD** function with the function selector switch first. Use the \wedge/\vee keys to select **Trip-out time** function. The following menu is displayed:



Figure 5.17: Trip-out time measurement menu

Connect test cable to the Eurotest instrument.

Step 2 Set the following measuring parameters:

- Nominal differential trip-out current,
- Nominal differential trip-out current multiplier,
- RCD type, and
- Test current starting polarity.

Step 3 Follow the connection diagram shown in figure 5.21 (see the chapter 5.4.6 *Contact voltage*) to perform trip-out time measurement.

Step 4 Check the displayed warnings and online voltage/terminal monitor before starting measurement. If OK, press the TEST key. After performing the measurement results with PASS/FAIL indication appear on the display.

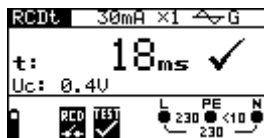

Figure 5.18: Example of trip-out time measurement results

Displayed results:

t Trip-out time,
U_c Contact voltage.

Save displayed results for documentation purposes. Refer to chapter 6.1. *Saving results* (MI 3002 and MI 3102).

Notes:

- Parameters set in this function are also kept for other RCD functions!
- RCD trip-out time measurement will be performed only if contact voltage at nominal differential current is lower than the set limit contact voltage!
- The measurement of contact voltage in pre-test does not normally trip an RCD. However, the trip limit may be exceeded as a result of leakage current flowing to the PE protective conductor or a capacitive connection between L and PE conductors.

5.3.8 Trip-out current

A continuously rising residual current is used for the evaluation of an RCD. After the measurement has been started, the test current generated by the instrument is continuously increased, starting at $0.2 \times I_{\Delta N}$ to $1.1 \times I_{\Delta N}$ (to $1.5 \times I_{\Delta N}$ / $2.2 \times I_{\Delta N}$ ($I_{\Delta N} = 10$ mA) for pulsating DC residual currents), until the RCD is tripped.

For additional general information concerning trip-out current measurement refer to the Metrel handbook *Measurements on electric installations in theory and practice*.

How to perform trip-out current measurement

Step 1 Select **RCD** function with the function selector switch first. Use the $\blacktriangle/\blacktriangledown$ keys to select **Trip-out current** function. The following menu is displayed:

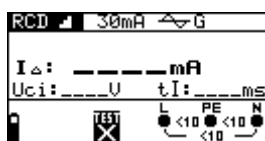

Figure 5.19: Trip-out current measurement menu

Connect test cable to the Eurotest instrument.

Step 2 By using cursor keys the following parameters can be set in this measurement:

- Nominal residual current,
- RCD type,
- Test current starting polarity.

Step 3 Follow the connection diagram shown in figure 5.21 (see the chapter 5.4.6 *Contact voltage*) to perform trip-out current measurement. Use the **Help** function if necessary.

Step 4 Check the displayed warnings and online voltage/terminal monitor before starting the measurement. If OK, press the TEST key. After performing the measurement results with PASS/FAIL indication appear on the display.



Figure 5.20: Example of trip-out current measurement result

Displayed results:

I_{Δ} Trip-out current,
 U_{ci} Contact voltage,
 tI Trip-out time.

Save displayed results for documentation purposes. Refer to chapter 6.1. *Saving results* (MI 3002 and MI 3102).

Notes:

- ❑ Parameters set in this function are also kept for other RCD functions!
- ❑ RCD trip-out current measurement will be performed only if contact voltage at nominal differential current is lower than set limit contact voltage!
- ❑ The measurement of contact voltage in pre-test does not normally trip an RCD. However, the trip limit may be exceeded as a result of leakage current flowing to the PE protective conductor or a capacitive connection between L and PE conductors.

5.3.9 Autotest

The purpose of autotest function is to perform complete RCD testing and measurement of belonging parameters (contact voltage, fault loop resistance and trip-out time at different fault currents) in one set of automatic tests, guided by the instrument. If any false parameter is noticed during autotest, individual parameter test has to be used for further investigation.

Notes:

- ❑ The measurement of contact voltage in pre-test does not normally trips an RCD. However, the trip limit may be exceeded as a result of leakage current flowing to the PE protective conductor or a capacitive connection between L and PE conductors.
- ❑ The autotest sequence stops when the trip-out time is out of allowed time period.

5.3.9.1 How to perform RCD autotest – standard version

Step 1 Select **RCD** function with the function selector switch first. Use the $\blacktriangle/\blacktriangledown$ keys to select **RCD autotest** function. The following menu is displayed:

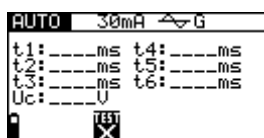

Figure 5.21: RCD autotest menu

Connect test cable to the Eurotest instrument.

Step 2 Set the following measuring parameters:

- ❑ Nominal differential trip-out current,
- ❑ RCD type.

Step 3 Follow the connection diagram shown in figure 5.21 (see the chapter 5.4.6 *Contact voltage*) to perform the RCD autotest. Use the **Help** function if necessary.

Step 4 Check the displayed warnings and online voltage/terminal monitor before starting the measurement. If OK, press the TEST key. The autotest sequence starts to run as follows:

1. Trip-out time measurement with the following measurement parameters:
 - Test current of $\frac{1}{2} \times I_{\Delta N}$,
 - Test current started with the positive half-wave at 0° .

Measurement does not normally trip an RCD. The following menu is displayed:

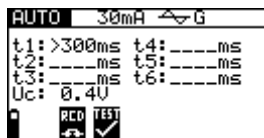

Figure 5.22: Step 1 RCD autotest results

After performing step 1 the RCD autotest sequence automatically proceeds with step 2.

2. Trip-out time measurement with the following measurement parameters:
 - Test current of $\frac{1}{2} \times I_{\Delta N}$,
 - Test current started with the negative half-wave at 180° .

Measurement does not normally trip an RCD. The following menu is displayed:

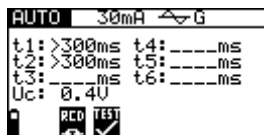

Figure 5.23: Step 2 RCD autotest results

After performing step 2 the RCD autotest sequence automatically proceeds with step 3.

3. Trip-out time measurement with the following measurement parameters:
 - Test current of $I_{\Delta N}$,
 - Test current started with the positive half-wave at 0° .

Measurement normally trips an RCD within allowed time period. The following menu is displayed:

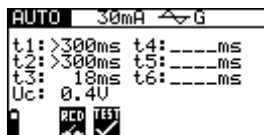

Figure 5.24: Step 3 RCD autotest results

After re-switching the RCD the autotest sequence automatically proceeds with step 4.

4. Trip-out time measurement with the following measurement parameters:
 - Test current of $I_{\Delta N}$,
 - Test current started with the negative half-wave at 180° .

Measurement normally trips an RCD within allowed time period. The following menu is displayed:

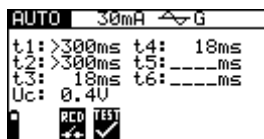

Figure 5.25: Step 4 RCD autotest results

After re-switching the RCD the autotest sequence automatically proceeds with step 5.

5. Trip-out time measurement with the following measurement parameters:

- Test current of $5 \times I_{\Delta N}$,
- Test current started with the positive half-wave at 0° .

Measurement normally trips an RCD within allowed time period. The following menu is displayed:

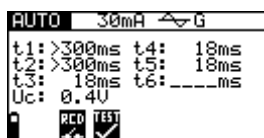

Figure 5.26: Step 5 RCD autotest results

After re-switching the RCD, the autotest sequence automatically proceeds with step 6.

6. Trip-out time measurement with the following measurement parameters:

- Test current of $5 \times I_{\Delta N}$,
- Test current started with the negative half-wave at 180° .

Measurement normally trips an RCD within allowed time period. The following menu is displayed:

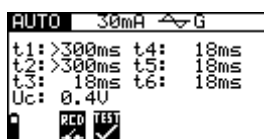

Figure 5.27: Step 6 RCD autotest results

Displayed results:

- t1** Step 1 trip-out time result ($\frac{1}{2} \times I_{\Delta N}$, 0°),
- t2** Step 2 trip-out time result ($\frac{1}{2} \times I_{\Delta N}$, 180°),
- t3** Step 3 trip-out time result ($I_{\Delta N}$, 0°),
- t4** Step 4 trip-out time result ($I_{\Delta N}$, 180°),
- t5** Step 5 trip-out time result ($5 \times I_{\Delta N}$, 0°),
- t6** Step 6 trip-out time result ($5 \times I_{\Delta N}$, 180°),
- Uc** Contact voltage.

Save displayed results for documentation purposes. Refer to chapter 6.1. *Saving results* (MI 3002 and MI 3102).

Note:

- Auto test is finished with t4 test in case of testing the RCD type A with rated residual currents of $I_{\Delta n} = 300 \text{ mA}$, 500 mA , and 1000 mA . In this case auto test result passes if t1 to t4 results pass, and on the display are omitted t5 and t6.

5.3.9.2 How to perform RCD autotest – UK version

Step 1 Select **RCD** function with the function selector switch first. Use the Δ/∇ keys to select **RCD autotest** function. The following menu is displayed:

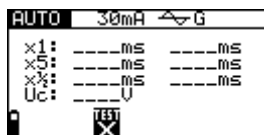

Figure 5.28: RCD autotest menu

Connect test cable to the Eurotest instrument.

Step 2 Set the following measuring parameters:

- Nominal differential trip-out current,
- RCD type.

Step 3 Follow the connection diagram shown in figure 5.21 (see the chapter 5.4.6 *Contact voltage*) to perform the RCD autotest. Use the **Help** function if necessary.

Step 4 Check the displayed warnings and online voltage/terminal monitor before starting the measurement. If OK, press the TEST key. The autotest sequence starts to run as follows:

1. Trip-out time measurement with the following measurement parameters:

- Test current of $I_{\Delta n}$,
- Test current started with the positive half-wave at 0° .

Measurement normally trips an RCD within allowed time period. The following menu is displayed:

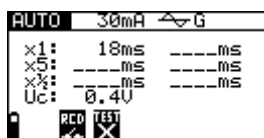

Figure 5.29: Step 1 RCD autotest results

After re-switching the RCD, the autotest sequence automatically proceeds with step 2.

2. Trip-out time measurement with the following measurement parameters:

- Test current of $I_{\Delta n}$,
- Test current started with the negative half-wave at 180° .

Measurement normally trips an RCD. The following menu is displayed:

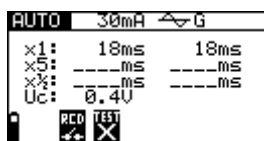

Figure 5.30: Step 2 RCD autotest results

After re-switching the RCD, the autotest sequence automatically proceeds with step 3.

3. Trip-out time measurement with the following measurement parameters:

- Test current of $5 \times I_{\Delta N}$,
- Test current started with the positive half-wave at 0° .

Measurement normally trips an RCD within allowed time period. The following menu is displayed:

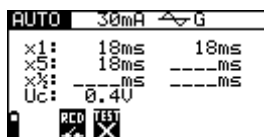

Figure 5.31: Step 3 RCD autotest results

After re-switching the RCD the autotest sequence automatically proceeds with step 4.

4. Trip-out time measurement with the following measurement parameters:

- Test current of $5 \times I_{\Delta N}$,
- Test current started with the negative half-wave at 180° .

Measurement normally trips an RCD within allowed time period. The following menu is displayed:

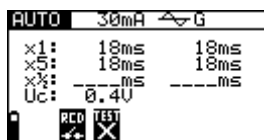

Figure 5.32: Step 4 RCD autotest results

After re-switching the RCD the autotest sequence automatically proceeds with step 5.

5. Trip-out time measurement with the following measurement parameters:

- Test current of $\frac{1}{2} \times I_{\Delta N}$,
- Test current started with the positive half-wave at 0° .

Measurement does not normally trip an RCD. The following menu is displayed:

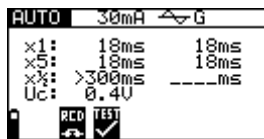

Figure 5.33: Step 5 RCD autotest results

After performing step 5 the RCD autotest sequence automatically proceeds with step 6.

6. Trip-out time measurement with the following measurement parameters:

- Test current of $\frac{1}{2} \times I_{\Delta N}$,
- Test current started with the negative half-wave at 180° .

Measurement does not normally trip an RCD. The following menu is displayed:

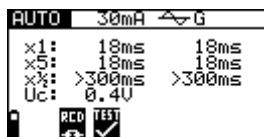

Figure 5.34: Step 6 RCD autotest results

Displayed results:

- x1** (left) Step 1 trip-out time result, $t_3 (I_{\Delta N}, 0^\circ)$,
- x1** (right) Step 2 trip-out time result, $t_4 (I_{\Delta N}, 180^\circ)$,
- x5** (left) Step 3 trip-out time result, $t_5 (5 \times I_{\Delta N}, 0^\circ)$,
- x5** (right) Step 4 trip-out time result, $t_6 (5 \times I_{\Delta N}, 180^\circ)$,
- x $\frac{1}{2}$** (left) Step 5 trip-out time result, $t_1 (\frac{1}{2} \times I_{\Delta N}, 0^\circ)$,
- x $\frac{1}{2}$** (right) ... Step 6 trip-out time result, $t_2 (\frac{1}{2} \times I_{\Delta N}, 180^\circ)$,
- Uc** Contact voltage.

Save displayed results for documentation purposes. Refer to chapter 6.1.
Saving results (MI 3002 and MI 3102).

Note:

- **x5** Auto tests are skipped in case of testing the RCD type A with rated residual currents of $I_{\Delta n} = 300 \text{ mA}$, 500 mA , and 1000 mA . In this case auto test result passes if t_1 to t_4 results pass, and on the display are omitted t_5 and t_6 .

5.4 Fault loop impedance and prospective fault current

Two loop impedance measuring sub-functions are available:

Z LOOP (in the UK version called **Zs**) sub-function performs fault loop impedance measurement in supply systems without RCDs.

Zs(rcd) trip-lock sub-function performs fault loop impedance measurement in supply systems equipped with an RCD.

5.4.1 Fault loop impedance

Fault loop impedance is the impedance within the fault loop when a short-circuit to an exposed conductive parts occurs (conductive connection between phase conductor and protective earth conductor). In order to measure loop impedance the instrument uses high test current.

Prospective fault current is calculated on basis of measured resistance as follows:

$$I_{PFC} = \frac{U_N \times \text{scaling factor}}{Z_{L-PE}}$$

where

Nominal input voltage U_N	Voltage range
115 V	$(100 \text{ V} \leq U_{L-PE} < 160 \text{ V})$
230 V	$(160 \text{ V} \leq U_{L-PE} \leq 264 \text{ V})$

Because of diverse definitions of the I_{PFC} in different countries the user can set the scaling factor in the **Setup** menu (see chapter 4.5.2 *Prospective short/fault current scaling factor adjustment*).

For additional general information concerning fault loop impedance measurement refer to the Metrel handbook *Measurements on electric installations in theory and practice*.

How to perform fault loop impedance measurement

Step 1 Select **LOOP** function with the function selector switch first. Use the $\blacktriangle/\blacktriangledown$ keys to select **Fault loop impedance** sub-function. The following menu is displayed:

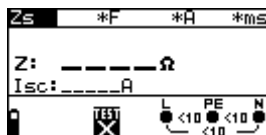

Figure 5.35: Loop impedance measurement menu

Connect test cable to the Eurotest instrument.

Step 2 Set the following measuring parameters:

- Fuse type,
- Fuse current rating,
- Fuse trip-out time,
- I_{PSC} scaling factor (see chapter 4.5.2 *Prospective short/fault current scaling factor adjustment*).

The complete list of available fuse types can be found in Appendix A.

Step 3 Follow the connection diagram shown in the figure 5.29 to perform fault loop impedance measurement. Use the **Help** function if necessary.

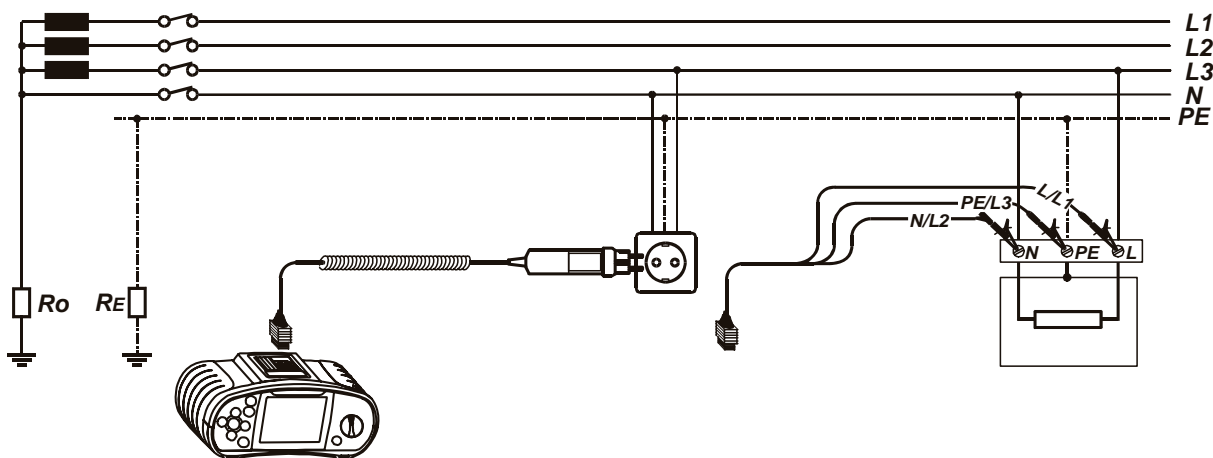

Figure 5.36: Connection of plug cable and universal test cable

Step 4 Check the displayed warnings and online voltage/terminal monitor before starting the measurement. If OK, press the TEST key. After performing the measurement results appear on the display together with the PASS/FAIL indication (if applicable).



Figure 5.37: Example of loop impedance measurement results

Displayed results:

- Z**Fault loop impedance,
- I_{sc}**Prospective fault current,
- Lim**Low limit prospective short-circuit current value or high limit fault loop impedance value in the UK version (if applicable).

Save displayed results for documentation purposes. Refer to chapter 6.1. *Saving results* (MI 3002 and MI 3102).

Notes:

- ❑ L and N test terminals are reversed automatically if L/L1 and N/L2 test leads (universal test cable) are connected in reversed way, or terminals of the tested wall plug are reversed, or plug commander is turned around (except in UK version).
- ❑ Low limit prospective short-circuit current value depends on fuse type, fuse current rating, fuse trip-out time and I_{PSC} scaling factor.
- ❑ Specified accuracy of tested parameters is valid only if mains voltage is stable during the measurement.
- ❑ Fault loop impedance measurement trips an RCD.

5.4.2 RCD trip-lock function

Fault loop impedance is measured with low-test current to avoid trip-out of the RCD. This function can also be used for fault loop impedance measurement in system equipped with RCDs with rated trip-out current of 10 mA.

Prospective fault current is calculated on basis of measured resistance as follows:

$$I_{PFC} = \frac{U_N \times \text{scaling factor}}{Z_{L-PE}}$$

where

Nominal input voltage U_N	Voltage range
115 V	(100 V \leq U_{L-PE} < 160 V),
230 V	(160 V \leq U_{L-PE} \leq 264 V),

Because of diverse definitions of the I_{PFC} in different countries the user can set the scaling factor in the **Setup** menu (see chapter 4.5.2 *Prospective short/fault current scaling factor adjustment*).

For additional general information concerning fault loop impedance measurement refer to the Metrel handbook *Measurements on electric installations in theory and practice*.

How to perform RCD trip-lock measurement

Step 1 Select **LOOP** function with the function selector switch first. Use the \uparrow/\downarrow keys to select **RCD trip-lock** sub-function. The following menu is displayed:

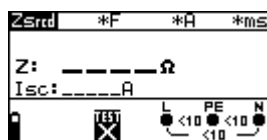

Figure 5.38: Trip-lock function menu

Connect test cable to the Eurotest instrument.

Step 2 Set the following measuring parameters:

- Fuse type,
- Fuse current rating,
- Fuse trip-out time,
- I_{PSC} scaling factor (see chapter 4.5.2 *Prospective short/fault current scaling factor adjustment*).

The complete list of available fuse types can be found in Appendix A.

Step 3 Follow the connection diagram shown in figure 5.21 to perform RCD trip-lock measurement (see chapter 5.4.6 *Contact voltage*). Use **Help** function if necessary.

Step 4 Check the displayed warnings and online voltage/terminal monitor before starting the measurement. If OK, press the TEST key. After performing the measurement the results appear on the display.



UK version

Figure 5.39: Example of fault loop impedance measurement results using trip-lock function

Displayed result:

Z Fault loop impedance,

I_{sc} Prospective fault current,

Lim Low limit prospective short-circuit current value or high limit fault loop impedance value in the UK version (if applicable).

Save displayed results for documentation purposes. Refer to chapter 6.1. *Saving results* (MI 3002 and MI 3102).

Notes:

- The measurement of fault loop impedance using trip-lock function does not normally trip an RCD. However, the trip limit may be exceeded as a result of leakage current flowing to the PE protective conductor or a capacitive connection between L and PE conductors.
- Specified accuracy of tested parameters is valid only if mains voltage is stable during the measurement.

5.5 Line impedance and prospective short-circuit current

Line impedance is the impedance within the current loop when a short-circuit to the neutral conductor occurs (conductive connection between phase conductor and neutral conductor in single-phase system or between two phase conductors in three-phase system). High test current is used to perform line resistance measurement.

Prospective short circuit current is calculated as follows:

$$I_{PSC} = \frac{U_N \times \text{scaling factor}}{Z_{L-N(L)}}$$

where

Nominal input voltage U_N	Voltage range
115 V	$(100 \text{ V} \leq U_{L-PE} < 160 \text{ V})$
230 V	$(160 \text{ V} \leq U_{L-PE} \leq 264 \text{ V})$
400 V	$(264 \text{ V} < U_{L-PE} \leq 440 \text{ V})$

Because of diverse definitions of the I_{PSC} in different countries the user can set the scaling factor in the **Setup** menu (See chapter 4.5.3).

For additional general information concerning line impedance refer to the Metrel handbook *Measurements on electric installations in theory and practice*.

How to perform line impedance measurement

Step 1 Select **LINE** function with function selector switch. The following menu is displayed:



Figure 5.40: Line impedance measurement menu

Connect test cable to the Eurotest instrument.

Step 2 Set the following measuring parameters:

- Fuse type,
- Fuse current rating,
- Fuse trip-out time,
- I_{PSC} scaling factor (see chapter 4.5.2 *Prospective short/fault current scaling factor adjustment*).

The complete list of available fuse types can be found in Appendix A.

Step 3 Follow the connection diagram shown in figure 5.40 to perform phase-neutral or phase-phase line impedance measurement. Use the **Help** function if necessary.

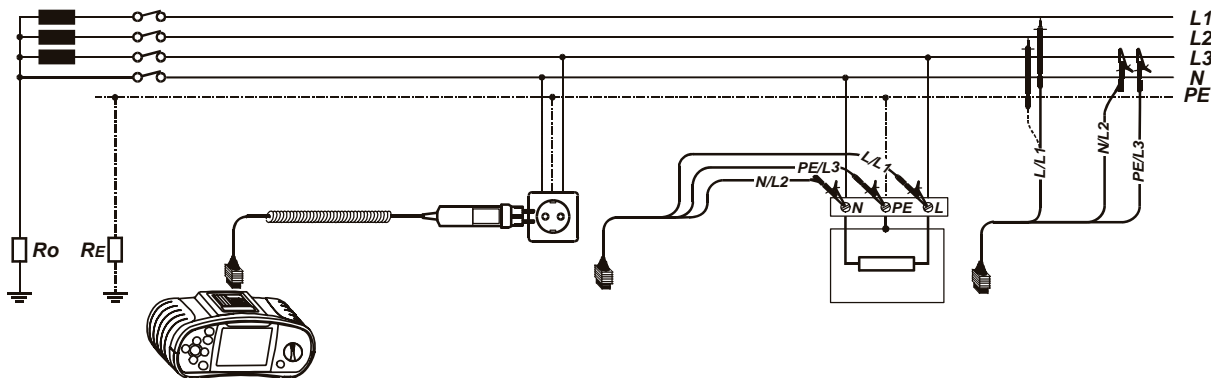

Figure 5.41: Phase-neutral or phase-phase line impedance measurement

Step 4 Check the displayed warnings and online voltage/terminal monitor before starting the measurement. If OK, press the TEST key. After performing the measurement results appear on the display together with the PASS/FAIL indication (if applicable).



Figure 5.42: Example of line impedance measurement results

Displayed results:

- Z**Line impedance,
- I_{sc}**Prospective short-circuit current,
- Lim**Low limit prospective short-circuit current value or high limit fault loop impedance value in the UK version (if applicable).

Save displayed results for documentation purposes. Refer to chapter 6.1. *Saving results* (MI 3002 and MI 3102).

Notes:

- ❑ Low limit prospective short-circuit current value depends on fuse type, fuse current rating, fuse trip-out time and I_{PSC} scaling factor.
- ❑ Specified accuracy of tested parameters is valid only if mains voltage is stable during the measurement.

5.6 Phase sequence testing

In practice we often deal with the connection of three-phase loads (motors and other electro-mechanical machines) to three-phase mains installation. Some loads (ventilators, conveyors, motors, electro-mechanical machines, etc.) require a specific phase rotation and some may even be damaged if the rotation is reversed. This is why it is advisable to test phase rotation before connection is made.

For general information concerning phase sequence testing refer to the Metrel handbook *Measurements on electric installations in theory and practice*.

How to test phase sequence

Step 1 Select **PHASE ROTATION** function with the function selector switch. The following menu is displayed.

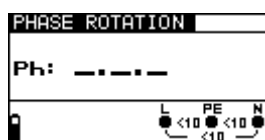

Figure 5.43: Phase rotation test menu

Connect test cable to the Eurotest instrument.

Step 2 Follow the connection diagram shown in figure 5.43 to test phase sequence.

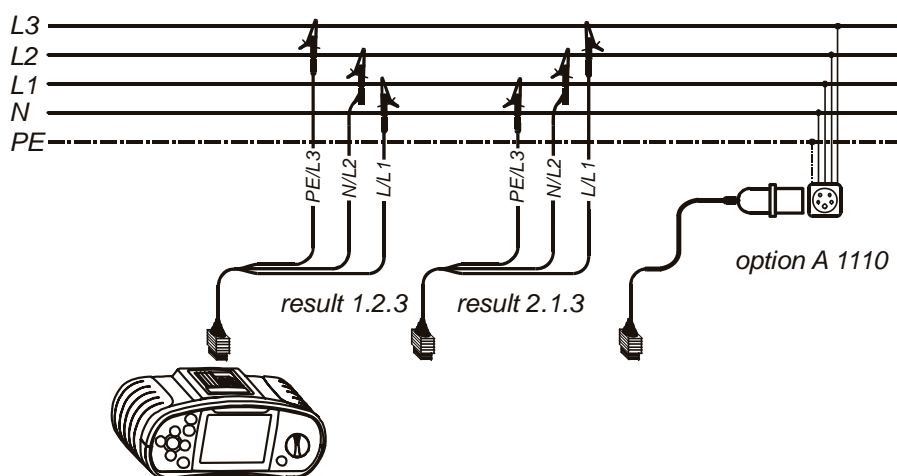

Figure 5.44: Connection of universal test cable and optional three phase cable

Step 3 Check the displayed warnings and online voltage/terminal monitor. Continuous test is running. Actual result is shown on the display during test. All three-phase voltages are displayed in order of their sequence represented by the numbers 1, 2 and 3.

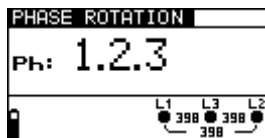

Figure 5.45: Example of phase sequence test result

Displayed results:

- Ph.....Phase sequence,
- 1.2.3.....Correct connection,
- 2.3.1.....Invalid connection,
- .-.....Irregular voltages.

Save displayed results for documentation purposes. Refer to chapter 6.1. *Saving results* (MI 3002 and MI 3102).

5.7 Voltage and frequency

Voltage measurement should be carried out often while dealing with electric installations (carrying out different measurements and tests, looking for fault locations, etc.). Frequency is measured for example when establishing the source of mains voltage (power transformer or individual generator).

How to perform voltage and frequency measurement

Step 1 Select **VOLTAGE** function with the function selector switch. The following menu is displayed:

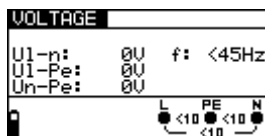

Figure 5.46: Voltage and frequency measurement menu

Connect test cable to the Eurotest instrument.

Step 2 Follow the connection diagram shown in figure 5.46 to perform voltage and frequency measurement.

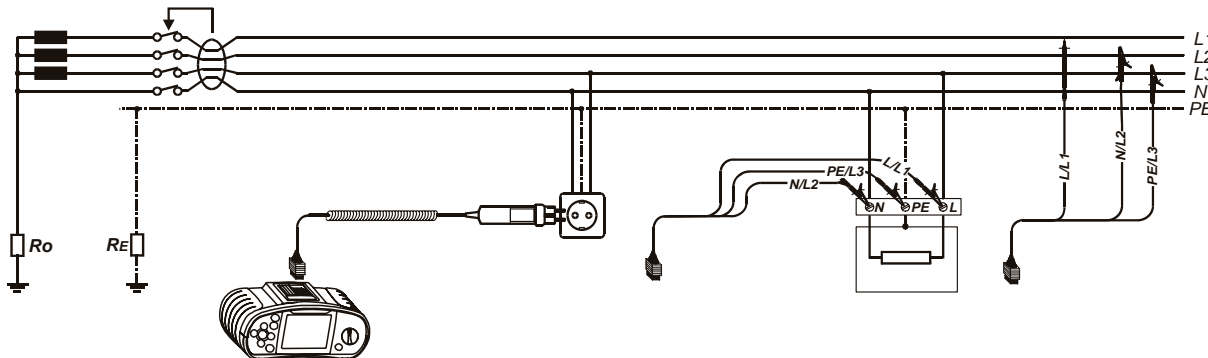

Figure 5.47: Connection diagram

Step 3 Check the displayed warnings. Continuous test is running. Actual results are shown on the display during measurement.

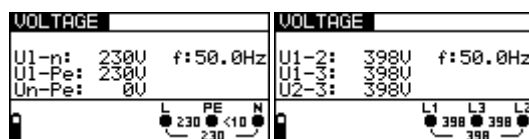

Figure 5.48: Examples of voltage and frequency measurements

Displayed results:

U1-n.....Voltage between phase and neutral conductors,

U1-pe.....Voltage between phase and protective conductors,

Un-peVoltage between neutral and protective conductors.

When testing three-phase system the following results are displayed:

U1-2.....Voltage between phases L1 and L2,

U1-3.....Voltage between phases L1 and L3,

U2-3.....Voltage between phases L2 and L3.

Save displayed results for documentation purposes. Refer to chapter 6.1.
Saving results (MI 3002 and MI 3102).

5.8 Resistance to earth (MI 3102 only)

EurotestXE allows resistance to earth measurement using 3-wire measuring method.

Consider the following instructions when performing resistance to earth measurement:

- The probe (S) is positioned between the earth electrode (E) and auxiliary earth electrode (H) in the ground reference plane (see figure 5.49).
- The distance from the earth electrode (E) to the auxiliary earth electrode (H) is at least 5 times the depth of earthing electrode rod or the length of the band electrode.
- If measuring the total earth resistance of a complex earthing system, the required distance depends on the longest diagonal distance between the individual earthing electrodes.

For additional general information concerning resistance to earth measurement refer to the METREL handbook *Measurements on electric installations in theory and practice*.

How to perform resistance to earth measurement

Step 1 Select the **EARTH** function with function selector switch. The following menu is displayed:

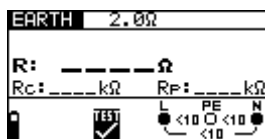

Figure 5.49: Earth resistance measurement menu

Connect test cable to the EurotestXE.

Step 2 Set the following measuring parameter:

- High limit resistance value.

Step 3 Follow the connection diagram shown in figure 5.49 to perform resistance to earth measurement. Use the **Help** function if necessary.

Test connector terminals are used as follows:

- L/L1 black test lead is used for the auxiliary earth electrode (H).
- N/L2 blue test lead is used for the earth electrode (E).
- PE/L3 green test lead is used for the probe (S).

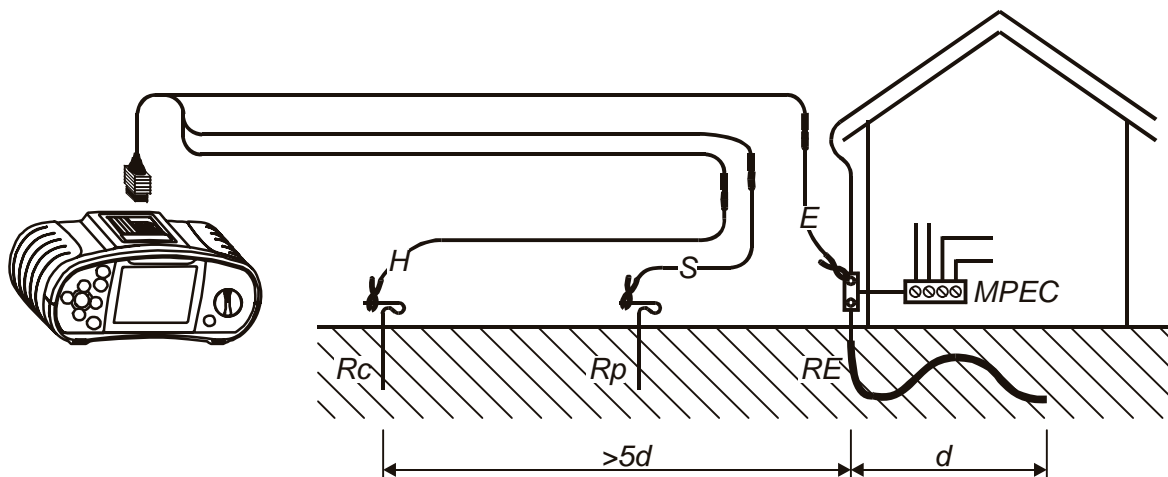

Figure 5.50: Connection of standard 20 m long test leads

Step 4 Check the displayed warnings and online voltage/terminal monitor before starting the measurement. If OK, press the TEST key. After performing the measurement results appear on the display together with the PASS/FAIL indication (if applicable).

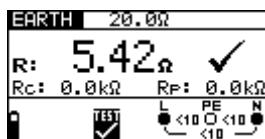

Figure 5.51: Example of resistance to earth measurement results

Displayed results:

- Rresistance to earth,
- R_Cauxiliary earth electrode resistance,
- R_Pprobe resistance.

Save displayed results for documentation purposes. Refer to chapter 6.1. *Saving results.*

Notes:

- If voltage between test terminals is higher than 30 V the resistance to earth measurement will not be performed.
- If a noise voltage higher than approx. 5 V is present between the H and E or S test terminals, “⚡” (noise) warning symbol will be displayed, indicating that the test result may not be correct!

5.9 TRMS current (MI 3102 only)

This function enables measuring of AC currents in a wide range from 0.5 mA to 20 A using sensitive current clamp (A 1018) supplied by METREL.

For additional general information concerning TRMS current measurement refer to the METREL handbook *Measurements on electric installations in theory and practice*.

How to perform TRMS current measurement

Step 1 Select **TRMS CURRENT** function with the function selector switch. The following menu is displayed:

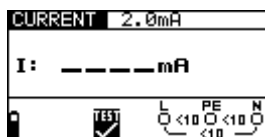

Figure 5.52: TRMS current measurement menu

Connect current clamp to the instrument clamp connector.

Step 2 Set the following limit value:

- High limit current value.

Step 3 Follow the connection diagram shown in Figure 5.53 to perform TRMS current measurement. Use the **Help** function if necessary.

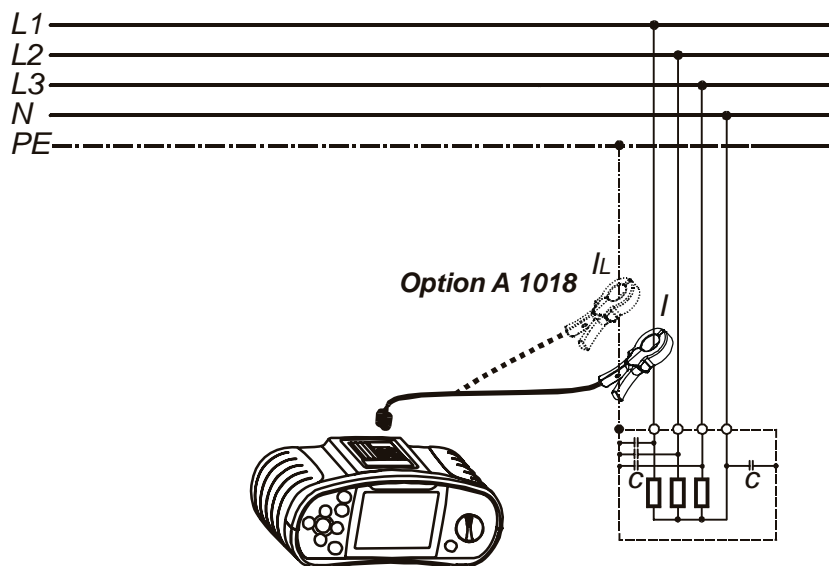

Figure 5.53: Connection diagram

Step 4 Check the displayed warnings before starting the measurement. If OK, press the TEST key.

To stop measurement at any time press the TEST key again. The last measured result is displayed, together with the PASS/FAIL indication (if applicable).

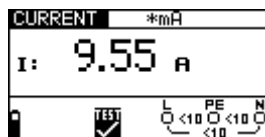

Figure 5.54: Example of TRMS current measurement result

Displayed results:

ITRMS current (or TRMS leakage current).

Save displayed results for documentation purposes. Refer to chapter 6.1. *Saving results.*

Notes:

- Use test clamp supplied by METREL or other with similar characteristics (current output 1000:1, appropriate measurement range, consider error of test clamp when evaluating measured results)!
- Current clamps Metrel A 1074 and A 1019 are suitable for use with MI 3102 EurotestXE instrument in range 0.2 A ÷ 200 A. Below 0.2 A they can be used as indicator only. They are not suitable for leakage current measurements.
- The only Metrel current clamps, suitable for leakage current measurements, are A 1018 (1000 A/1 A).

5.10 Illumination (MI 3102 only)

The illumination measurements should be performed whenever planning or installing indoor or outdoor lighting.

Illumination measurement can be performed using LUXmeter probe connected to the RS232 connector of the instrument. The EurotestXE instrument supports LUXmeter type B and LUXmeter type C probes.

How to perform illumination measurement

Step 1 Select **SENSOR** function with the function selector switch. The following menu is displayed:



Figure 5.55: Illumination measurement menu

Connect LUXmeter probe to the instrument RS232 connector.

Step 2 Set the following limit value:

- Low limit illumination value.

Step 3 Follow the positioning diagram shown in figure 5.55 to perform illumination measurement. Turn on the LUXmeter probe by pressing its ON/OFF key. Green LED should light. Use the **Help** function if necessary.

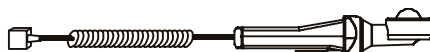
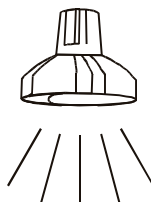

Figure 5.56: LUXmeter probe positioning

Step 4 Check the displayed warnings before starting measurement. If OK, press the TEST key to start the measurement. Actual measuring result with PASS/FAIL indication (if applicable) is shown on the display during measurement. To stop measurement at any time press the TEST key again. The last measured result is displayed, together with the PASS/FAIL indication (if applicable).



Figure 5.57: Example of illumination measurement result

Displayed result:

E Illumination

Save displayed results for documentation purposes. Refer to chapter 6.1. *Saving results.*

Notes:

- For accurate measurement make sure that the milk glass bulb is lit without any shadows cast by hand, body or other unwanted objects.
- It is very important to know that the artificial light sources reach full power of operation after a period of time (see technical data for light sources) and should be therefore switched on for this period of time before the measurements are taken.

5.11 Testing PE terminal

In new or adapted installations it may occur that the PE conductor is reversed with the phase conductor – this is a very dangerous situation! This is why it is important to test for the presence of phase voltage at the PE protection terminal.

The test is performed before tests where mains supply voltage is applied to the instrument circuitry or before installation is used.

For additional general information concerning PE terminal test, refer to the Metrel handbook *Measurements on electric installations in theory and practice*.

How to test PE terminal

Step 1 Connect test cable to the instrument.

Step 2 Follow the connection diagrams shown in figures 5.57 and 5.58 to test PE terminal.

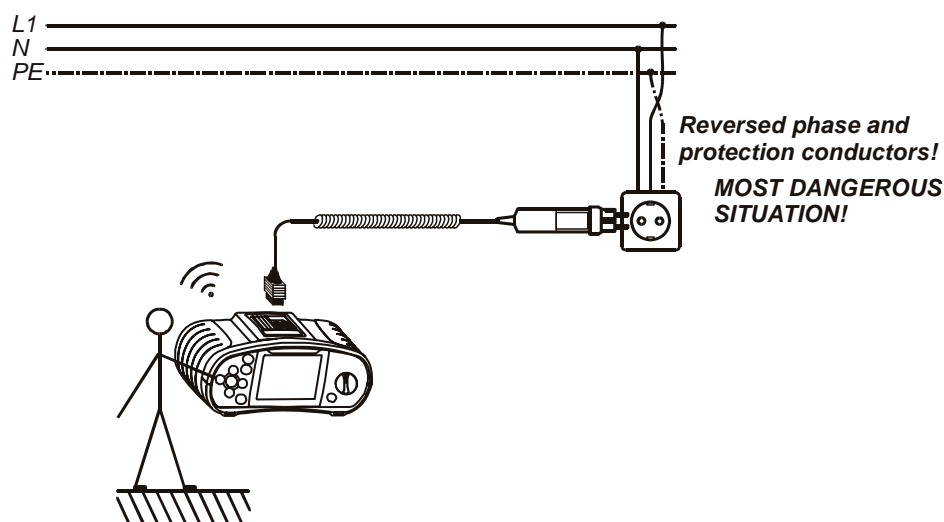

Figure 5.58: Connection of plug cable to mains outlet with reversed L and PE conductors

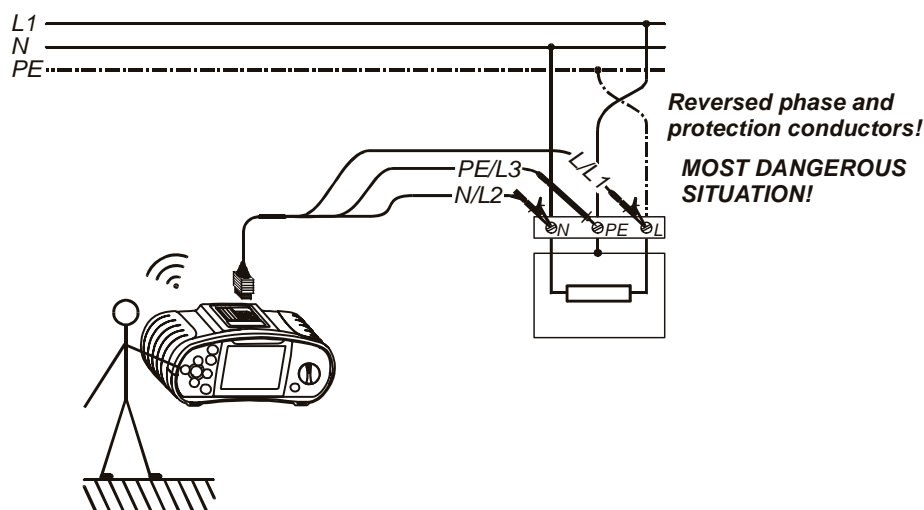

Figure 5.59: Connection of universal test cable to load connection terminals with reversed L and PE conductors

Step 3 Touch the PE test probe (TEST key) for a few seconds. If PE terminal is connected to phase voltage, warning message is displayed and instrument buzzer is activated.

Warning:

- If phase voltage is detected on tested PE terminal, stop all measurements immediately and take care the fault is eliminated before proceeding with any activity!

Notes:

- PE terminal can be tested in RCD, LOOP and LINE function selector switch positions only!
- For correct testing of PE terminal, the TEST key has to be touched for a few seconds.
- Make sure to stand on non-isolated floor while carrying out the test, otherwise test result may be wrong!

6 Working with results (MI 3002 and MI 3102)

After the measurement is completed, results can be stored to the flash memory of the instrument, together with the sub-results and function parameters.

Electrical installations can be represented as a multi-level structure. Memory locations of EurotestXE instrument are organized in three-level structure as follows:

- Object (1st structure level, the highest level),
- Block (2nd structure level),
- Fuse (3th structure level, the lowest level).

Three-digit codes (000 ÷ 999) are used instead of object, block and fuse names.

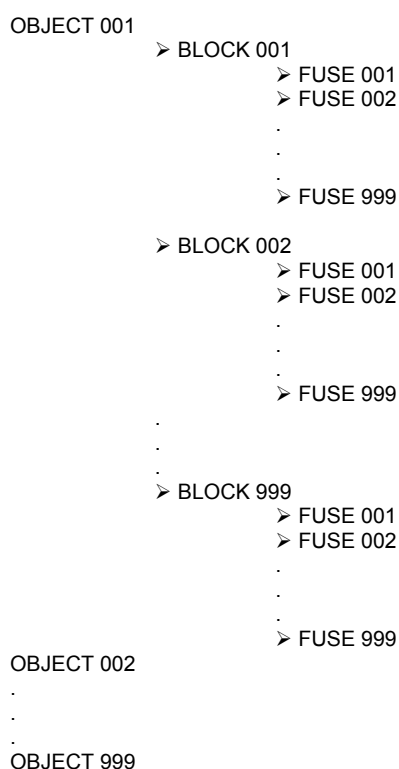
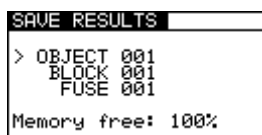

Figure 6.1: Instrument memory organization

6.1 Saving results

How to save measurement results

Step 1 When the measurement is finished, press the MEM key. The following menu is displayed:



```
SAVE RESULTS
> OBJECT 001
  BLOCK 001
  FUSE 001
Memory free: 100%
```

Figure 6.2: Save results menu

Step 2 The results can be saved into selected memory location as follows:

By using the \uparrow/\downarrow keys set cursor to **Object** line. Use the \leftarrow/\rightarrow keys to select appropriate object three-digit code.

By using the \uparrow/\downarrow keys set cursor to **Block** line. Use the \leftarrow/\rightarrow keys to select appropriate block three-digit code.

By using the \uparrow/\downarrow keys set cursor to **Fuse** line. Use the \leftarrow/\rightarrow keys to select appropriate fuse three-digit code.

Step 3 Press the MEM key to save the results. »Saved to memory« message is displayed for a while. After saving the results the instrument returns to measurement menu.

Note:

- Each measurement result can be saved only once.

6.2 Recalling results

In **Memory** menu the results can be:

- ❑ Recalled from the memory,
- ❑ Deleted from the memory.

To enter **Memory** menu press the MEM key.

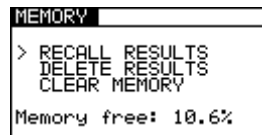

Figure 6.3: Memory menu

How to search for and recall saved results

Step 1 Select **Recall results** from **Memory** menu by using the ▲ and ▼ keys and press the TEST key to confirm. The following menu is displayed.

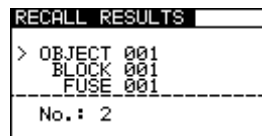

Figure 6.4: Recall results menu

Step 2 When searching for saved results all three-digit codes can be used to narrow the hits as follows:

By using the ▲/▼ keys set cursor to **Object** line. Use the </> keys to select appropriate object three-digit code.

By using the ▲/▼ keys set cursor to **Block** line. Use the </> keys to select appropriate block three-digit code.

By using the ▲/▼ keys set cursor to **Fuse** line. Use the </> keys to select appropriate fuse three-digit code.

In **No.** line the number of stored results is displayed.

Step 3 Set cursor to the **No.** line by using the ▲/▼ keys.

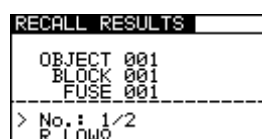

Figure 6.5: Recall results menu

Use the \leftarrow/\rightarrow keys to select function for which you want to view results. Press the TEST key to confirm.

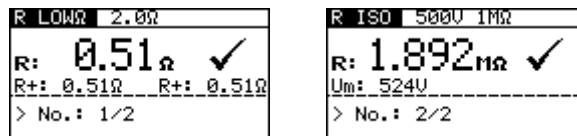

Figure 6.6: Examples of recall results menu

By using the \leftarrow/\rightarrow keys other saved results can be viewed under the same object, block and fuse items. Press the \blacktriangle or \blacktriangledown key to return to **Recall results** menu.

6.3 Deleting results

When deleting results the following actions can be taken:

- ❑ Individual results can be deleted,
- ❑ Results under the same structure item can be deleted,
- ❑ All saved results can be deleted.

To enter **Memory** menu press the MEM key.

How to delete individual saved results

Step 1 Select **Delete results** from **Memory** menu by using the ▲ and ▼ keys and press the TEST key to confirm. The following menu is displayed.

```

DELETED RESULTS
> OBJECT 001
  BLOCK 001
  FUSE 001
-----
No. : 2
  
```

Figure 6.7: Delete results menu 1

Step 2 Select results you want to delete from the memory as follows:

By using the ▲/▼ keys set cursor to **Object** line. Use the </> keys to select appropriate object three-digit code.

By using the ▲/▼ keys set cursor to **Block** line. Use the </> keys to select appropriate block three-digit code.

By using the ▲/▼ keys set cursor to **Fuse** line. Use the </> keys to select appropriate fuse three-digit code.

In **No.** line the number of stored results is displayed.

Step 3 Set cursor to the **No.** line using ▲/▼ keys.

```

DELETED RESULTS
OBJECT 001
BLOCK 001
FUSE 001
-----
> No. : 1/2
  R LOWR
  
```

Figure 6.8: Delete results menu 2

Use the </> keys to select function for which you want to delete results. Press the TEST key. Press the TEST key again for confirmation or press any cursor key (or MEM key) to return to **Delete results** menu without deleting selected saved results.

How to delete saved results under the same structure item

Step 1 Select **Delete results** from **Memory** menu by using the \blacktriangle and \blacktriangledown keys and press the TEST key to confirm. The following menu is displayed.

```

DELETED RESULTS
-----
> OBJECT 001
  BLOCK 001
  FUSE 001
-----
No.: 2
  
```

Figure 6.9: Delete results menu 1

Step 2 Follow the instructions below to delete selected results.

Deleting results from the 3th structure level

By using the \blacktriangle / \blacktriangledown keys set cursor to **Fuse** line. Use the \blacktriangleleft / \blacktriangleright keys to select appropriate fuse three-digit code. In **No.** line the number of saved results is displayed.

```

DELETED RESULTS
-----
OBJECT 001
BLOCK 001
> FUSE 002
-----
No.: 5
  
```

Figure 6.10: Deleting results from the 3th level

Continue with instructions under **Step 3**.

Deleting results from the 2nd structure level

By using the \blacktriangle / \blacktriangledown keys set cursor to **Block** line. Use the \blacktriangleleft / \blacktriangleright keys to select appropriate block three-digit code. In **No.** line the number of stored results is displayed.

```

DELETED RESULTS
-----
OBJECT 001
> BLOCK 003
  FUSE 002
-----
No.: 2
  
```

Figure 6.11: Deleting results from the 2nd level

Note:

- Selected fuse item has no influence on deleted results.

Continue with instructions under **Step 3**.

Deleting results from the 1st structure level

By using the \blacktriangle / \blacktriangledown keys set cursor to **Object** line. Use the \blacktriangleleft / \blacktriangleright keys to select appropriate object three-digit code. In **No.** line the number of stored results is displayed.

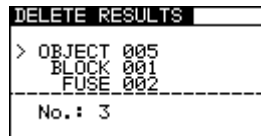

Figure 6.12: Deleting results from the 1st level

Note:

- Selected block and fuse items have no influence on deleting results.

Continue with instructions under **Step 3**.

Step 3 Press the TEST key. Press the TEST key again for confirmation or press any cursor key (or MEM key) to return to **Delete results** menu without deleting selected results.

How to delete all saved results

Step 1 Select **Clear memory** from **Memory** menu by using the ▲ and ▼ keys and press the TEST key to confirm. The following menu is displayed:



Figure 6.13: Clear memory menu

Step 2 Press the TEST key again for confirmation or press any cursor key (or MEM key) to return to **Memory** menu without deleting all saved results.

7 RS232 / USB communication (MI 3002 and MI 3102 only)

EurotestXE includes both RS232 and USB communication ports. Stored results can be sent to PC for additional activities.

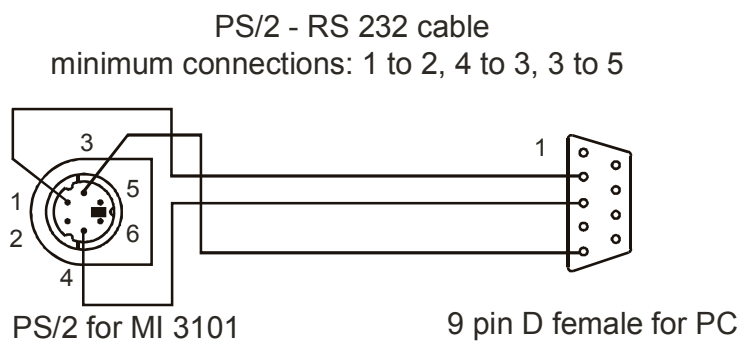

Figure 7.1: Interface connection for data transfer over PC COM port

7.1 EuroLinkXE PC software

EuroLinkXE allows the following activities:

- ❑ Data downloading,
- ❑ Simple report creation,
- ❑ Export of measured data to a spreadsheet.

The EuroLinkXE is a PC software running on Windows 95/98, Windows NT, Windows 2000 and Windows XP.

How to download saved results to PC

Step 1 Connect the EurotestXE instrument to PC using RS232 or USB cable. Make sure that correct communication port is selected. Refer to chapter 4.5.4 *Communication port selection*.

Step 2 Run EuroLinkXE PC software.

Step 3 Select **Receive results** icon or **Instrument / Receive results** option from menu. EuroLinkXE starts to download results saved in the instrument. After results are downloaded the following memory structure is displayed.

n	Location	Function	Results	Parameters	Limits	Date Time
16	001 001 002	RCD I	Id = 21.0 mA Uci = 27.6 V t = 18 ms	SYS TN/TT Idn = 30 mA phase: 0° type: General_AC	Uc < 50 V	
17	001 001 002	RCD I	Id = 21.0 mA Uci = 27.6 V t = 18 ms	SYS TN/TT Idn = 30 mA phase: 0° type: General_AC	Uc < 50 V	
18	001 001 002	RCD I	Id = 21.0 mA Uci = 27.6 V t = 18 ms	SYS TN/TT Idn = 30 mA phase: 0° type: General_AC	Uc < 50 V	
19	001 001 002	RCD I	Id = 21.0 mA Uci = 27.6 V t = 18 ms	SYS TN/TT Idn = 30 mA phase: 0° type: General_AC	Uc < 50 V	
20	001 001 002	RCD I	Id = 21.0 mA Uci = 27.6 V t = 18 ms	SYS TN/TT Idn = 30 mA phase: 0° type: General_AC	Uc < 50 V	
21	001 001 002	RCD I	Id = 21.0 mA Uci = 27.6 V t = 18 ms	SYS TN/TT Idn = 30 mA phase: 0° type: General_AC	Uc < 50 V	
22	001 001 002	RCD I	Id = 21.0 mA Uci = 27.6 V t = 18 ms	SYS TN/TT Idn = 30 mA phase: 0° type: General_AC	Uc < 50 V	
23	001 001 002	RCD I	Id = 21.0 mA Uci = 27.6 V t = 18 ms	SYS TN/TT Idn = 30 mA phase: 0° type: General_AC	Uc < 50 V	
24	001 001 002	RCD I	Id = 21.0 mA Uci = 27.6 V t = 18 ms	SYS TN/TT Idn = 30 mA phase: 0° type: General_AC	Uc < 50 V	
25	001 001 002	RCD I	Id = 21.0 mA Uci = 27.6 V t = 18 ms	SYS TN/TT Idn = 30 mA phase: 0° type: General_AC	Uc < 50 V	
26	001 001 002	RCD I	Id = 21.0 mA Uci = 27.6 V t = 18 ms	SYS TN/TT Idn = 30 mA phase: 0° type: General_AC	Uc < 50 V	
27	001 001 002	RCD I	Id = 21.0 mA Uci = 27.6 V t = 18 ms	SYS TN/TT Idn = 30 mA phase: 0° type: General_AC	Uc < 50 V	
28	001 001 002	RCD I	Id = 21.0 mA Uci = 27.6 V t = 18 ms	SYS TN/TT Idn = 30 mA phase: 0° type: General_AC	Uc < 50 V	
29	001 001 002	RCD I	Id = 21.0 mA Uci = 27.6 V t = 18 ms	SYS TN/TT Idn = 30 mA phase: 0° type: General_AC	Uc < 50 V	
30	001 001 002	RCD I	Id = 21.0 mA Uci = 27.6 V t = 18 ms	SYS TN/TT Idn = 30 mA phase: 0° type: General_AC	Uc < 50 V	
31	001 001 002	RCD I	Id = 21.0 mA Uci = 27.6 V t = 18 ms	SYS TN/TT Idn = 30 mA phase: 0° type: General_AC	Uc < 50 V	

Figure 7.2: Example of downloaded results

Step 4 Edit downloaded structure for SYS documentation purposes.

Note:

- USB drivers should be installed on PC before using the USB interface. See accompanying CD for further instructions about USB installation.

8 Maintenance

8.1 Replacing fuses

There are three fuses under back cover of the Eurotest instrument.

- F1
M 0.315 A / 250 V, 20×5 mm
This fuse protects internal circuitry of low-value resistance function if test probes are connected to the mains supply voltage by mistake.
- F2, F3
F 4 A / 500 V, 32×6.3 mm
General input protection fuses of test terminals L/L1 and N/L2.

Warnings:

-  Disconnect any measuring accessory and power off the instrument before opening battery/fuse compartment cover, hazardous voltage inside!
- Replace blown fuse with original type only, otherwise the instrument may be damaged and/or operator's safety impaired!

Position of fuses can be seen in figure 3.4 in chapter 3.3 Back panel.

8.2 Cleaning

No special maintenance is required for the housing. To clean the surface of the instrument use a soft cloth slightly moistened with soapy water or alcohol. Then leave the instrument to dry totally before use.

Warnings:

- Do not use liquids based on petrol or hydrocarbons!
- Do not spill cleaning liquid over the instrument!

8.3 Periodic calibration

It is essential that the test instrument is regularly calibrated in order technical specification listed in this manual can be guaranteed. We recommend an annual calibration. The calibration should be done by an authorised technical person only. Please contact your dealer for further information.

8.4 Service

For repairs under warranty, or at any other time, please contact your distributor. Unauthorised person is not allowed to open the Eurotest instrument. There are no user replaceable components inside the instrument, except three fuses, refer to chapter 8.1 *Replacing fuses*.

9 Technical specifications

9.1 Insulation resistance

Insulation resistance (nominal voltages 100 V_{DC} and 250 V_{DC})

Measuring range according to EN61557-2 is 0.017 MΩ ÷ 199.9 MΩ.

Measuring range (MΩ)	Resolution (MΩ)	Accuracy
0.000 ÷ 1.999	0.001	±(5 % of reading + 3 digits)
2.00 ÷ 99.99	0.01	
100.0 ÷ 199.9	0.1	

Insulation resistance (nominal voltages 500 V_{DC} and 1000 V_{DC})

Measuring range according to EN61557-2 is 0.015 MΩ ÷ 999 MΩ.

Measuring range (MΩ)	Resolution (MΩ)	Accuracy
0.000 ÷ 1.999	0.001	±(2 % of reading + 3 digits)
2.00 ÷ 99.99	0.01	
100.0 ÷ 199.9	0.1	
200 ÷ 999	1	±(10 % of reading)

Voltage

Measuring range (V)	Resolution (V)	Accuracy
0 ÷ 1200	1	±(3 % of reading + 3 digits)

Nominal voltages 100 V_{DC}, 250 V_{DC}, 500 V_{DC}, 1000 V_{DC}

Open circuit voltage -0 % / +20 % of nominal voltage

Measuring current..... min. 1 mA at R_N=U_N×1 kΩ/V

Short circuit current..... max. 3 mA

Specified accuracy is valid if universal test cable is used, while it is valid up to 200 MΩ if tip commander is used.

The number of possible tests

with a new set of batteries up to 1800

Auto discharge after test.

In case the instrument gets moistened the results could be impaired. In such case it is recommended to dry the instrument and accessories for at least 24 hours.

9.2 Continuity resistance

9.2.1 LowΩ resistance

Measuring range according to EN61557-4 is 0.16 Ω ÷ 1999 Ω.

Measuring range (Ω)	Resolution (Ω)	Accuracy
0.00 ÷ 19.99	0.01	±(3 % of reading + 3 digits)
20.0 ÷ 99.9	0.1	±(5 % of reading)
100 ÷ 1999	1	

Open-circuit voltage..... $6.5 V_{DC} \div 9 V_{DC}$
 Measuring current..... min. 200 mA into load resistance of 2 Ω
 Test lead compensation..... up to 5 Ω
 The number of possible tests
 with a new set of batteries up to 5500
 Automatic polarity reversal of the test voltage.

9.2.2 Continuity

Measuring range (Ω)	Resolution (Ω)	Accuracy
0.0 \div 99.9	0.1	$\pm(5\% \text{ of reading} + 3 \text{ digits})$
100 \div 1999	1	

Open-circuit voltage..... $6.5 V_{DC} \div 9 V_{DC}$
 Short-circuit current max. 8.5 mA
 Test lead compensation..... up to 5 Ω

9.3 RCD testing

9.3.1 General data

Nominal residual current..... 10 mA, 30 mA, 100 mA, 300 mA, 500 mA,
 1000 mA
 Nominal residual current accuracy.... $-0 / +0.1 \cdot I_{\Delta}$; $I_{\Delta} = I_{\Delta N}, 2 \times I_{\Delta N}, 5 \times I_{\Delta N}$
 $-0.1 \cdot I_{\Delta} / +0$; $I_{\Delta} = \frac{1}{2} \times I_{\Delta N}$
 Test current shape..... Sine-wave (AC), pulsed (A)
 RCD type general (G, non-delayed), selective (S, time-
 delayed)
 Test current starting polarity 0° or 180°
 Voltage range 100 V \div 264 V (45 Hz \div 65 Hz)

RCD test current selection (r.m.s. value calculated to 20 ms) according to IEC 61009:

$I_{\Delta N}$ (mA)	$\frac{1}{2} \times I_{\Delta N}$		$1 \times I_{\Delta N}$		$2 \times I_{\Delta N}$		$5 \times I_{\Delta N}$		RCD I_{Δ}	
	AC	A	AC	A	AC	A	AC	A	AC	A
10	5	3,5	10	20	20	40	50	100	✓	✓
30	15	10,5	30	42	60	84	150	212	✓	✓
100	50	35	100	141	200	282	500	707	✓	✓
300	150	105	300	424	600	848	1500	*)	✓	✓
500	250	175	500	707	1000	1410	2500	*)	✓	✓
1000	500	350	1000	1410	2000	*)	*)	*)	✓	✓

*) not available

9.3.2 Contact voltage

Measuring range according to EN61557-6 is 3.0 V ÷ 49.0 V for limit contact voltage 25 V.

Measuring range according to EN61557-6 is 3.0 V ÷ 99.0 V for limit contact voltage 50 V.

Measuring range (V)	Resolution (V)	Accuracy
0.0 ÷ 9.9	0.1	(-0 % / +10 %) of reading + 2 digits
10.0 ÷ 99.9	0.1	(-0 % / +10 %) of reading

Accuracy applies for 1 year in reference conditions. Temperature coefficient outside these limits is +1 digit.

Test current max. $0.5 \times I_{\Delta N}$

Limit contact voltage 25 V, 50 V

Fault loop resistance at contact voltage is calculated as $R_L = \frac{U_C}{I_{\Delta N}}$.

9.3.3 Trip-out time

Complete measurement range corresponds to EN61557-6 requirements. Specified accuracies are valid for complete operating range.

General (non-delayed) RCDs

Measuring range (ms)	Resolution (ms)	Accuracy
0 ÷ 300 ($\frac{1}{2} \times I_{\Delta N}$, $I_{\Delta N}$)	1	±3 ms
0 ÷ 150 ($2 \times I_{\Delta N}$)	1	
0 ÷ 40 ($5 \times I_{\Delta N}$)	1	

Selective (time-delayed) RCDs

Measuring range (ms)	Resolution (ms)	Accuracy
0 ÷ 500 ($\frac{1}{2} \times I_{\Delta N}$, $I_{\Delta N}$)	1	±3 ms
0 ÷ 200 ($2 \times I_{\Delta N}$)	1	
0 ÷ 150 ($5 \times I_{\Delta N}$)	1	

Test current $\frac{1}{2} \times I_{\Delta N}$, $I_{\Delta N}$, $2 \times I_{\Delta N}$, $5 \times I_{\Delta N}$

Multiplier 5 is not available if $I_{\Delta N} = 1000$ mA (AC type RCDs) or $I_{\Delta N} \geq 300$ mA (A type RCDs).

Multiplier 2 is not available if $I_{\Delta N} = 1000$ mA (A type RCDs).

9.3.4 Trip-out current

Trip-out current ($I_{\Delta N} = 10$ mA)

Measurement range corresponds to EN61557-6 requirements. Specified accuracies are valid for complete operating range.

Measuring range I_{Δ}	Resolution I_{Δ}	Accuracy
$0.2 \times I_{\Delta N} \div 1.1 \times I_{\Delta N}$ (AC type)	$0.05 \times I_{\Delta N}$	$\pm 0.1 \times I_{\Delta N}$
$0.2 \times I_{\Delta N} \div 2.2 \times I_{\Delta N}$ (A type)	$0.05 \times I_{\Delta N}$	$\pm 0.1 \times I_{\Delta N}$

Trip-out current ($I_{\Delta N} \geq 30$ mA)

Measurement range corresponds to EN61557-6 requirements. Specified accuracies are valid for complete operating range.

Measuring range I_{Δ}	Resolution I_{Δ}	Accuracy
$0.2 \times I_{\Delta N} \div 1.1 \times I_{\Delta N}$ (AC type)	$0.05 \times I_{\Delta N}$	$\pm 0.1 \times I_{\Delta N}$
$0.2 \times I_{\Delta N} \div 1.5 \times I_{\Delta N}$ (A type)	$0.05 \times I_{\Delta N}$	$\pm 0.1 \times I_{\Delta N}$

Trip-out time

Measuring range (ms)	Resolution (ms)	Accuracy
0 ÷ 300	1	± 3 ms

Contact voltage

Measuring range (V)	Resolution (V)	Accuracy
0.0 ÷ 9.9	0.1	(-0 % / +10 %) of reading + 2 digits
10.0 ÷ 99.9	0.1	(-0 % / +10 %) of reading

9.4 Fault loop impedance and prospective fault current

Z LOOP (Zs in the UK version) sub-function

Measuring range according to EN61557-3 is $0.25 \Omega \div 1999 \Omega$.

Measuring range (Ω)	Resolution (Ω)	Accuracy
0.00 ÷ 19.99	0.01	$\pm(5\% \text{ of reading} + 5 \text{ digits})$
20.0 ÷ 99.9	0.1	
100 ÷ 1999	1	

Prospective fault current (calculated value)

Measuring range (A)	Resolution (A)	Accuracy
0.00 ÷ 19.99	0.01	Consider accuracy of fault loop resistance measurement
20.0 ÷ 99.9	0.1	
100 ÷ 999	1	
1.00k ÷ 9.99k	10	
10.0 ÷ 24.4k	100	

Test current (at 230 V)..... 7.5 A ($10 \text{ ms} \leq t_{\text{LOAD}} \leq 15 \text{ ms}$)

Nominal voltage range..... 100 V ÷ 264 V (45 Hz ÷ 65 Hz)

Zs(rcd) trip-lock sub-function

Measuring range according to EN61557 is $0.46 \Omega \div 1999 \Omega$.

Measuring range (Ω)	Resolution (Ω)	Accuracy ^{*)}
0.00 ÷ 19.99	0.01	$\pm(5\% \text{ of reading} + 10 \text{ digits})$
20.0 ÷ 99.9	0.1	$\pm 10\% \text{ of reading}$
100 ÷ 1999	1	$\pm 10\% \text{ of reading}$

^{*)} Accuracy may be impaired in case of heavy noise on mains voltage.

Prospective fault current (calculated value)

Measuring range (A)	Resolution (A)	Accuracy
0.00 ÷ 19.99	0.01	Consider accuracy of fault loop resistance measurement
20.0 ÷ 99.9	0.1	
100 ÷ 999	1	
1.00k ÷ 9.99k	10	
10.0 ÷ 24.4k	100	

No trip out of RCD.

9.5 Line impedance and prospective short-circuit current

Line impedance

Measuring range according to EN61557-3 is 0.25 Ω ÷ 1999 Ω.

Measuring range (Ω)	Resolution (Ω)	Accuracy
0.00 ÷ 19.99	0.01	±(5 % of reading + 5 digits)
20.0 ÷ 99.9	0.1	
100 ÷ 1999	1	

Prospective short-circuit current (calculated value)

Measuring range (A)	Resolution (A)	Accuracy
0.00 ÷ 19.99	0.01	Consider accuracy of line resistance measurement
20.0 ÷ 99.9	0.1	
100 ÷ 999	1	
1.00k ÷ 9.99k	10	
10.0 ÷ 24.4k	100	

Test current (at 230 V)..... 7.5 A ($10 \text{ ms} \leq t_{\text{LOAD}} \leq 15 \text{ ms}$)

Nominal voltage range 100 V ÷ 440 V (45 Hz ÷ 65 Hz)

9.6 Resistance to earth (MI 3102 only)

Measuring range according to EN61557-5 is 2.00 Ω ÷ 1999 Ω.

Measuring range (Ω)	Resolution (Ω)	Accuracy
0.00 ÷ 19.99	0.01	±(2 % of reading + 3 digits)
20.0 ÷ 99.9	0.1	
100 ÷ 1999	1	

Max. auxiliary earth electrode

resistance R_C $100 \times R_E$ or 50 kΩ (whichever is lower)

Max. probe resistance R_P $100 \times R_E$ or 50 kΩ (whichever is lower)

Additional probe resistance error

at $R_{C\text{max}}$ or $R_{P\text{max}}$ ±(10 % of reading + 10 digits)

Additional error

at 3 V voltage noise (50 Hz) ±(5 % of reading + 10 digits)

Open circuit voltage < 45 V_{AC}
 Short circuit voltage < 20 mA
 Test voltage frequency 125 Hz
 Test voltage shape rectangular
 Noise voltage indication threshold 1 V (< 50 Ω, worst case)

Automatic measurement of auxiliary electrode resistance and probe resistance.
 Automatic measurement of voltage noise.

9.7 TRMS current (MI 3102 only)

TRMS current or TRMS leakage current

Measuring range (A)	Resolution (A)	Accuracy
0.0 ÷ 99.9 mA	0.1 mA	±(5 % of reading + 3 digits)
100 ÷ 999 mA	1 mA	±(5 % of reading)
1.00 ÷ 19.99 A	0.01 A	

Input resistance 100 Ω
 Maximal continuous input current 30 mA (=30 A @ current clamp with ratio 1000:1)
 Measurement principle current clamp, ratio 1000:1
 Nominal frequency 45 Hz ÷ 65 Hz
 Additional clamp error has to be considered.

9.8 Illumination (MI 3102 only)

9.8.1 Illumination (LUXmeter type B)

Specified accuracy is valid for complete operating range.

Measuring range (lux)	Resolution (lux)	Accuracy
0.01 ÷ 19.99	0.01	±(5 % of reading + 2 digits)
0.1 ÷ 199.9	0.1	±(5 % of reading)
200 ÷ 1999	1	
2.00 ÷ 19.99 k	10	

Measurement principle silicon photodiode with V(λ) filter
 Spectral response error < 3.8 % according to CIE curve
 Cosine error < 2.5 % up to an incident angle of ± 85°
 Overall accuracy matched to DIN 5032 class B standard

9.8.2 Illumination (LUXmeter type C)

Specified accuracy is valid for complete operating range.

Measuring range (lux)	Resolution (lux)	Accuracy
0.01 ÷ 19.99	0.01	±(10 % of reading + 3 digits)
0.1 ÷ 199.9	0.1	±(10 % of reading)
200 ÷ 1999	1	
2.00 ÷ 19.99 k	10	

Measurement principle silicon photodiode
 Cosine error < 2.5 % up to an incident angle of $\pm 85^\circ$
 Overall accuracy matched to DIN 5032 class C standard

9.9 Phase rotation

Nominal mains voltage range 100 V_{AC} ÷ 440 V_{AC}
 Nominal frequency range 45 Hz ÷ 65 Hz
 Result displayed 1.2.3 or 2.1.3

9.10 Voltage and frequency

Measuring range (V)	Resolution (V)	Accuracy
0 ÷ 500	1	$\pm(2\% \text{ of reading} + 2 \text{ digits})$

Nominal frequency range 0 Hz, 45 Hz ÷ 65 Hz

Measuring range (Hz)	Resolution (Hz)	Accuracy
45.0 ÷ 65.0	0.1	$\pm 2 \text{ digits}$

Nominal voltage range 10 V ÷ 500 V

9.11 Online voltage monitor

Measuring range (V)	Resolution (V)	Accuracy
0 ÷ 500	1	$\pm(2\% \text{ of reading} + 2 \text{ digits})$

Nominal frequency range 0 Hz, 45 Hz ÷ 65 Hz

If voltage greater than 500 V is applied to the test terminals, online voltage monitor is used as voltage indicator only.

9.12 General data

Power supply voltage 9 V_{DC} (6×1.5 V battery cells, size AA)
 Power supply adapter 12 V ÷ 15 V / 400 mA
 Battery charging current < 250 mA (internally regulated)
 Operation typical 15 h

Overvoltage category CAT III / 600 V; CAT IV / 300 V
 Plug commander (optional)
 overvoltage category CAT III / 300 V

Protection classification double insulation
Pollution degree..... 2
Protection degree IP 42

Display 128×64 dots matrix display with backlight

Dimensions (w × h × d) 23 cm × 10.3 cm × 11.5 cm
Weight (without battery)..... 1.31 kg

Reference conditions

Reference temperature range 10 °C ÷ 30 °C
Reference humidity range 40 %RH ÷ 70 %RH

Operating conditions

Working temperature range 0 °C ÷ 40 °C
Maximum relative humidity..... 95 %RH (0 °C ÷ 40 °C), non-condensing

Storage conditions

Temperature range -10 °C ÷ +70 °C
Maximum relative humidity..... 90 %RH (-10 °C ÷ +40 °C)
80 %RH (40 °C ÷ 60 °C)

The error in operating conditions could be at most the error for reference conditions (specified in the manual for each function) + 1 % of measured value + 1 digit unless otherwise specified.

A Fuse base tables

A.1 Fuse base table

Fuse type	Fuse trip-out time	Fuse current rating	Low I _{PSC} value (A)
NV	35 ms	2 A	32.5
NV	35 ms	4 A	65.6
NV	35 ms	6 A	102.8
NV	35 ms	10 A	165.8
NV	35 ms	16 A	206.9
NV	35 ms	20 A	276.8
NV	35 ms	25 A	361.3
NV	35 ms	35 A	618.1
NV	35 ms	50 A	919.2
NV	35 ms	63 A	1.22 k
NV	35 ms	80 A	1.57 k
NV	35 ms	100 A	2.08 k
NV	35 ms	125 A	2.83 k
NV	35 ms	160 A	3.54 k
NV	35 ms	200 A	4.56 k
NV	35 ms	250 A	6.03 k
NV	35 ms	315 A	7.77 k
NV	35 ms	400 A	10.6 k
NV	35 ms	500 A	13.6 k
NV	35 ms	630 A	19.6 k
NV	35 ms	710 A	19.7 k
NV	35 ms	800 A	25.3 k
NV	35 ms	1000 A	34.4 k
NV	35 ms	1250 A	45.6 k
NV	0.1 s	2 A	22.3
NV	0.1 s	4 A	46.4
NV	0.1 s	6 A	70.0
NV	0.1 s	10 A	115.3
NV	0.1 s	16 A	150.8
NV	0.1 s	20 A	204.2
NV	0.1 s	25 A	257.5
NV	0.1 s	35 A	453.2
NV	0.1 s	50 A	640.0
NV	0.1 s	63 A	821.7
NV	0.1 s	80 A	1.13 k
NV	0.1 s	100 A	1.43 k
NV	0.1 s	125 A	2.01 k
NV	0.1 s	160 A	2.49 k
NV	0.1 s	200 A	3.49 k
NV	0.1 s	250 A	4.40 k
NV	0.1 s	315 A	6.07 k
NV	0.1 s	400 A	7.93 k
NV	0.1 s	500 A	10.9 k

Fuse type	Fuse trip-out time	Fuse current rating	Low I _{PSC} value (A)
NV	0.1 s	630 A	14.0 k
NV	0.1 s	710 A	17.8 k
NV	0.1 s	800 A	20.1 k
NV	0.1 s	1000 A	23.6 k
NV	0.1 s	1250 A	36.2 k
NV	0.2 s	2 A	18.7
NV	0.2 s	4 A	38.8
NV	0.2 s	6 A	56.5
NV	0.2 s	10 A	96.5
NV	0.2 s	16 A	126.1
NV	0.2 s	20 A	170.8
NV	0.2 s	25 A	215.4
NV	0.2 s	35 A	374.0
NV	0.2 s	50 A	545.0
NV	0.2 s	63 A	663.3
NV	0.2 s	80 A	964.9
NV	0.2 s	100 A	1.20 k
NV	0.2 s	125 A	1.71 k
NV	0.2 s	160 A	2.04 k
NV	0.2 s	200 A	2.97 k
NV	0.2 s	250 A	3.62 k
NV	0.2 s	315 A	4.99 k
NV	0.2 s	400 A	6.63 k
NV	0.2 s	500 A	8.83 k
NV	0.2 s	630 A	11.5 k
NV	0.2 s	710 A	14.3 k
NV	0.2 s	800 A	16.2 k
NV	0.2 s	1000 A	19.4 k
NV	0.2 s	1250 A	29.2 k
NV	0.4 s	2 A	15.9
NV	0.4 s	4 A	31.9
NV	0.4 s	6 A	46.4
NV	0.4 s	10 A	80.7
NV	0.4 s	16 A	107.4
NV	0.4 s	20 A	145.5
NV	0.4 s	25 A	180.2
NV	0.4 s	35 A	308.7
NV	0.4 s	50 A	464.2
NV	0.4 s	63 A	545.0
NV	0.4 s	80 A	836.5
NV	0.4 s	100 A	1.02 k
NV	0.4 s	125 A	1.45 k
NV	0.4 s	160 A	1.68 k

Fuse type	Fuse trip-out time	Fuse current rating	Low I _{PSC} value (A)
NV	0.4 s	200 A	2.53 k
NV	0.4 s	250 A	2.92 k
NV	0.4 s	315 A	4.10 k
NV	0.4 s	400 A	5.45 k
NV	0.4 s	500 A	7.52 k
NV	0.4 s	630 A	9.31 k
NV	0.4 s	710 A	12.0 k
NV	0.4 s	800 A	13.5 k
NV	0.4 s	1000 A	16.2 k
NV	0.4 s	1250 A	24.4 k
NV	5 s	2 A	9.1
NV	5 s	4 A	18.7
NV	5 s	6 A	26.7
NV	5 s	10 A	46.4
NV	5 s	16 A	66.3
NV	5 s	20 A	86.7
NV	5 s	25 A	109.3
NV	5 s	35 A	169.5
NV	5 s	50 A	266.9
NV	5 s	63 A	319.1
NV	5 s	80 A	447.9
NV	5 s	100 A	585.4
NV	5 s	125 A	765.1
NV	5 s	160 A	947.9
NV	5 s	200 A	1.35 k
NV	5 s	250 A	1.59 k
NV	5 s	315 A	2.27 k
NV	5 s	400 A	2.77 k
NV	5 s	500 A	3.95 k
NV	5 s	630 A	4.99 k
NV	5 s	710 A	6.42 k
NV	5 s	800 A	7.25 k
NV	5 s	1000 A	9.15 k
NV	5 s	1250 A	13.1 k
gG	35 ms	2 A	32.5
gG	35 ms	4 A	65.6
gG	35 ms	6 A	102.8
gG	35 ms	10 A	165.8
gG	35 ms	13 A	193.1
gG	35 ms	16 A	206.9
gG	35 ms	20 A	276.8
gG	35 ms	25 A	361.3
gG	35 ms	32 A	539.1
gG	35 ms	35 A	618.1
gG	35 ms	40 A	694.2
gG	35 ms	50 A	919.2
gG	35 ms	63 A	1.22 k

Fuse type	Fuse trip-out time	Fuse current rating	Low I _{PSC} value (A)
gG	35 ms	80 A	1.57 k
gG	35 ms	100 A	2.08 k
gG	0.1 s	2 A	22.3
gG	0.1 s	4 A	46.4
gG	0.1 s	6 A	70.0
gG	0.1 s	10 A	115.3
gG	0.1 s	13 A	144.8
gG	0.1 s	16 A	150.8
gG	0.1 s	20 A	204.2
gG	0.1 s	25 A	257.5
gG	0.1 s	32 A	361.5
gG	0.1 s	35 A	453.2
gG	0.1 s	40 A	464.2
gG	0.1 s	50 A	640.0
gG	0.1 s	63 A	821.7
gG	0.1 s	80 A	1.13 k
gG	0.1 s	100 A	1.43 k
gG	0.2 s	2 A	18.7
gG	0.2 s	4 A	38.8
gG	0.2 s	6 A	56.5
gG	0.2 s	10 A	96.5
gG	0.2 s	13 A	117.9
gG	0.2 s	16 A	126.1
gG	0.2 s	20 A	170.8
gG	0.2 s	25 A	215.4
gG	0.2 s	32 A	307.9
gG	0.2 s	35 A	374.0
gG	0.2 s	40 A	381.4
gG	0.2 s	50 A	545.0
gG	0.2 s	63 A	663.3
gG	0.2 s	80 A	964.9
gG	0.2 s	100 A	1.20 k
gG	0.4 s	2 A	15.9
gG	0.4 s	4 A	31.9
gG	0.4 s	6 A	46.4
gG	0.4 s	10 A	80.7
gG	0.4 s	13 A	100.0
gG	0.4 s	16 A	107.4
gG	0.4 s	20 A	145.5
gG	0.4 s	25 A	180.2
gG	0.4 s	32 A	271.7
gG	0.4 s	35 A	308.7
gG	0.4 s	40 A	319.1
gG	0.4 s	50 A	464.2
gG	0.4 s	63 A	545.0
gG	0.4 s	80 A	836.5
gG	0.4 s	100 A	1.02 k

Fuse type	Fuse trip-out time	Fuse current rating	Low I _{PSC} value (A)
gG	5 s	2 A	9.1
gG	5 s	4 A	18.7
gG	5 s	6 A	26.7
gG	5 s	10 A	46.4
gG	5 s	13 A	56.2
gG	5 s	16 A	66.3
gG	5 s	20 A	86.7
gG	5 s	25 A	109.3
gG	5 s	32 A	159.1
gG	5 s	35 A	169.5
gG	5 s	40 A	190.1
gG	5 s	50 A	266.9
gG	5 s	63 A	319.1
gG	5 s	80 A	447.9
gG	5 s	100 A	585.4
B	35 ms	6 A	30.0
B	35 ms	10 A	50.0
B	35 ms	13 A	65.0
B	35 ms	16 A	80.0
B	35 ms	20 A	100.0
B	35 ms	25 A	125.0
B	35 ms	32 A	160.0
B	35 ms	40 A	200.0
B	35 ms	50 A	250.0
B	35 ms	63 A	315.0
B	0.1 s	6 A	30.0
B	0.1 s	10 A	50.0
B	0.1 s	13 A	65.0
B	0.1 s	16 A	80.0
B	0.1 s	20 A	100.0
B	0.1 s	25 A	125.0
B	0.1 s	32 A	160.0
B	0.1 s	40 A	200.0
B	0.1 s	50 A	250.0
B	0.1 s	63 A	315.0
B	0.2 s	6 A	30.0
B	0.2 s	10 A	50.0
B	0.2 s	13 A	65.0
B	0.2 s	16 A	80.0
B	0.2 s	20 A	100.0
B	0.2 s	25 A	125.0
B	0.2 s	32 A	160.0
B	0.2 s	40 A	200.0
B	0.2 s	50 A	250.0
B	0.2 s	63 A	315.0
B	0.4 s	6 A	30.0
B	0.4 s	10 A	50.0

Fuse type	Fuse trip-out time	Fuse current rating	Low I _{PSC} value (A)
B	0.4 s	13 A	65.0
B	0.4 s	16 A	80.0
B	0.4 s	20 A	100.0
B	0.4 s	25 A	125.0
B	0.4 s	32 A	160.0
B	0.4 s	40 A	200.0
B	0.4 s	50 A	250.0
B	0.4 s	63 A	315.0
B	5 s	6 A	30.0
B	5 s	10 A	50.0
B	5 s	13 A	65.0
B	5 s	16 A	80.0
B	5 s	20 A	100.0
B	5 s	25 A	125.0
B	5 s	32 A	160.0
B	5 s	40 A	200.0
B	5 s	50 A	250.0
B	5 s	63 A	315.0
C	35 ms	0.5 A	5.0
C	35 ms	1.0 A	10.0
C	35 ms	1.6 A	16.0
C	35 ms	2 A	20.0
C	35 ms	4 A	40.0
C	35 ms	6 A	60.0
C	35 ms	10 A	100.0
C	35 ms	13 A	130.0
C	35 ms	16 A	160.0
C	35 ms	20 A	200.0
C	35 ms	25 A	250.0
C	35 ms	32 A	320.0
C	35 ms	40 A	400.0
C	35 ms	50 A	500.0
C	35 ms	63 A	630.0
C	0.1 s	0.5 A	5.0
C	0.1 s	1.0 A	10.0
C	0.1 s	1.6 A	16.0
C	0.1 s	2 A	20.0
C	0.1 s	4 A	40.0
C	0.1 s	6 A	60.0
C	0.1 s	10 A	100.0
C	0.1 s	13 A	130.0
C	0.1 s	16 A	160.0
C	0.1 s	20 A	200.0
C	0.1 s	25 A	250.0
C	0.1 s	32 A	320.0
C	0.1 s	40 A	400.0
C	0.1 s	50 A	500.0

Fuse type	Fuse trip-out time	Fuse current rating	Low I _{PSC} value (A)
C	0.1 s	63 A	630.0
C	0.2 s	0.5 A	5.0
C	0.2 s	1.0 A	10.0
C	0.2 s	1.6 A	16.0
C	0.2 s	2 A	20.0
C	0.2 s	4 A	40.0
C	0.2 s	6 A	60.0
C	0.2 s	10 A	100.0
C	0.2 s	13 A	130.0
C	0.2 s	16 A	160.0
C	0.2 s	20 A	200.0
C	0.2 s	25 A	250.0
C	0.2 s	32 A	320.0
C	0.2 s	40 A	400.0
C	0.2 s	50 A	500.0
C	0.2 s	63 A	630.0
C	0.4 s	0.5 A	5.0
C	0.4 s	1.0 A	10.0
C	0.4 s	1.6 A	16.0
C	0.4 s	2 A	20.0
C	0.4 s	4 A	40.0
C	0.4 s	6 A	60.0
C	0.4 s	10 A	100.0
C	0.4 s	13 A	130.0
C	0.4 s	16 A	160.0
C	0.4 s	20 A	200.0
C	0.4 s	25 A	250.0
C	0.4 s	32 A	320.0
C	0.4 s	40 A	400.0
C	0.4 s	50 A	500.0
C	0.4 s	63 A	630.0
C	5 s	0.5 A	2.7
C	5 s	1.0 A	5.4
C	5 s	1.6 A	8.6
C	5 s	2 A	10.8
C	5 s	4 A	21.6
C	5 s	6 A	32.4
C	5 s	10 A	54.0
C	5 s	13 A	70.2
C	5 s	16 A	86.4
C	5 s	20 A	108.0
C	5 s	25 A	135.0
C	5 s	32 A	172.8
C	5 s	40 A	216.0
C	5 s	50 A	270.0
C	5 s	63 A	340.2
K	35 ms	0.5 A	7.5

Fuse type	Fuse trip-out time	Fuse current rating	Low I _{PSC} value (A)
K	35 ms	1.0 A	15.0
K	35 ms	1.6 A	24.0
K	35 ms	2 A	30.0
K	35 ms	4 A	60.0
K	35 ms	6 A	90.0
K	35 ms	10 A	150.0
K	35 ms	13 A	195.0
K	35 ms	16 A	240.0
K	35 ms	20 A	300.0
K	35 ms	25 A	375.0
K	35 ms	32 A	480.0
K	0.1 s	0.5 A	7.5
K	0.1 s	1.0 A	15.0
K	0.1 s	1.6 A	24.0
K	0.1 s	2 A	30.0
K	0.1 s	4 A	60.0
K	0.1 s	6 A	90.0
K	0.1 s	10 A	150.0
K	0.1 s	13 A	195.0
K	0.1 s	16 A	240.0
K	0.1 s	20 A	300.0
K	0.1 s	25 A	375.0
K	0.1 s	32 A	480.0
K	0.2 s	0.5 A	7.5
K	0.2 s	1.0 A	15.0
K	0.2 s	1.6 A	24.0
K	0.2 s	2 A	30.0
K	0.2 s	4 A	60.0
K	0.2 s	6 A	90.0
K	0.2 s	10 A	150.0
K	0.2 s	13 A	195.0
K	0.2 s	16 A	240.0
K	0.2 s	20 A	300.0
K	0.2 s	25 A	375.0
K	0.2 s	32 A	480.0
K	0.4 s	0.5 A	7.5
K	0.4 s	1.0 A	15.0
K	0.4 s	1.6 A	24.0
K	0.4 s	2 A	30.0
K	0.4 s	4 A	60.0
K	0.4 s	6 A	90.0
K	0.4 s	10 A	150.0
K	0.4 s	13 A	195.0
K	0.4 s	16 A	240.0
K	0.4 s	20 A	300.0
K	0.4 s	25 A	375.0
K	0.4 s	32 A	480.0

Fuse type	Fuse trip-out time	Fuse current rating	Low I _{PSC} value (A)
D	35 ms	0.5 A	10.0
D	35 ms	1.0 A	20.0
D	35 ms	1.6 A	32.0
D	35 ms	2 A	40.0
D	35 ms	4 A	80.0
D	35 ms	6 A	120.0
D	35 ms	10 A	200.0
D	35 ms	13 A	260.0
D	35 ms	16 A	320.0
D	35 ms	20 A	400.0
D	35 ms	25 A	500.0
D	35 ms	32 A	640.0
D	0.1 s	0.5 A	10.0
D	0.1 s	1.0 A	20.0
D	0.1 s	1.6 A	32.0
D	0.1 s	2 A	40.0
D	0.1 s	4 A	80.0
D	0.1 s	6 A	120.0
D	0.1 s	10 A	200.0
D	0.1 s	13 A	260.0
D	0.1 s	16 A	320.0
D	0.1 s	20 A	400.0
D	0.1 s	25 A	500.0
D	0.1 s	32 A	640.0
D	0.2 s	0.5 A	10.0
D	0.2 s	1.0 A	20.0
D	0.2 s	1.6 A	32.0
D	0.2 s	2 A	40.0
D	0.2 s	4 A	80.0
D	0.2 s	6 A	120.0
D	0.2 s	10 A	200.0
D	0.2 s	13 A	260.0
D	0.2 s	16 A	320.0
D	0.2 s	20 A	400.0
D	0.2 s	25 A	500.0
D	0.2 s	32 A	640.0
D	0.4 s	0.5 A	10.0
D	0.4 s	1.0 A	20.0
D	0.4 s	1.6 A	32.0
D	0.4 s	2 A	40.0
D	0.4 s	4 A	80.0
D	0.4 s	6 A	120.0
D	0.4 s	10 A	200.0
D	0.4 s	13 A	260.0
D	0.4 s	16 A	320.0
D	0.4 s	20 A	400.0
D	0.4 s	25 A	500.0

Fuse type	Fuse trip-out time	Fuse current rating	Low I _{PSC} value (A)
D	0.4 s	32 A	640.0
D	5 s	0.5 A	2.7
D	5 s	1.0 A	5.4
D	5 s	1.6 A	8.6
D	5 s	2 A	10.8
D	5 s	4 A	21.6
D	5 s	6 A	32.4
D	5 s	10 A	54.0
D	5 s	13 A	70.2
D	5 s	16 A	86.4
D	5 s	20 A	108.0
D	5 s	25 A	135.0
D	5 s	32 A	172.8

A.2 Fuse base table (UK version only)

Fuse type B

Rated current (A)	Disconnection time [s]		Rated current (A)	Disconnection time [s]			
		0.4		5		0.4	5
	Max. loop impedance (Ω)			Max. loop impedance (Ω)			
3		12,264	12,264				
6		6,136	6,136	6		3,064	3,064
10		3,68	3,68	10		1,84	1,84
16		2,296	2,296	16		1,152	1,152
20		1,84	1,84	20		0,92	0,92
25		1,472	1,472	25		0,736	0,736
32		1,152	1,152	32		0,576	0,576
40		0,92	0,92	40		0,456	0,456
50		0,736	0,736	50		0,368	0,368
63		0,584	0,584	63		0,288	0,288
80		0,456	0,456	80		0,232	0,232
100		0,368	0,368	100		0,184	0,184
125		0,296	0,296	125		0,144	0,144

Fuse type C

Fuse type D

Rated current (A)	Disconnection time [s]		Rated current (A)	Disconnection time [s]			
		0.4		5		0.4	5
	Max. loop impedance (Ω)			Max. loop impedance (Ω)			
6		1,536	1,536	5		8,36	13,12
10		0,92	0,92	15		2,624	4
16		0,576	0,576	20		1,36	2,24
20		0,456	0,456	30		0,92	1,472
25		0,368	0,368	45			0,768
32		0,288	0,288	60			0,56
40		0,232	0,232	80			0,4
50		0,184	0,184	100			0,288
63		0,144	0,144				
80		0,112	0,112				
100		0,088	0,088				
125		0,072	0,072				

Fuse type BS 1361

Fuse type BS 88

Rated current (A)	Disconnection time [s]		Max. loop impedance (Ω)
	0.4	5	
	6	6,816	
10	4,088	5,936	
16	2,16	3,344	
20	1,416	2,328	
25	1,152	1,84	
32	0,832	1,472	
40		1,08	
50		0,832	
63		0,656	
80		0,456	
100		0,336	
125		0,264	
160		0,2	
200		0,152	

Fuse type BS 1362

Rated current (A)	Disconnection time [s]		Max. loop impedance (Ω)
	0.4	5	
	3	13,12	
13	1,936	3,064	

Fuse type BS 3036			
Rated current (A)	Disconnection time [s]		Max. loop impedance (Ω)
	0.4	5	
	5	7,664	
15	2,04	4,28	
20	1,416	3,064	
30	0,872	2,112	
45		1,272	
60		0,896	
100		0,424	

All impedances are scaled with factor 0.8.

B IT supply systems

In order for operator to be familiar enough with measurements in and their typical applications in IT supply system it is advisable to read Metrel handbook *Measurements on IT power supply systems*.

B.1 Standard references

EN 60364-4-41, EN 60364-6, EN 60364-7-710, BS 7671

B.2 Fundamentals

IT supply system is mains supply system that is insulated from ground (PE) – it is ungrounded supplying system. The system is without direct connection to the ground or the connection is provided through relatively high impedance. It is applied mostly in areas where additional protection to electric shock is required. Typical places are medical surgery rooms.

IT supply system also omits any grounding currents except leakages, and in this way there aren't problems with step voltage, i.e. voltage drop in one step, neither high energy sparking in Ex areas.

In normal cases the high impedance to the ground exists and is formed by capacitances of supply wires to the ground plus capacitances between primary and secondary windings of IT supply transformer. Minor part is formed by Y capacitors (EMC) in mains section of connected equipment. Selecting appropriate transformer, installation cabling and selection of optional high impedance connection to ground can control maximum leakage current.

Depending on application area additional impedance to the ground can be applied as presented in *figure D.1* or through special loading equipment. Value of the impedance should begin from 100 Ω .

IT system represents additional level of protection to electric shock. In the case of a failure of any line insulation to the PE through equipment failure, wrong application or procedure, this system is still safe but converted to TN / TT type. However, additional failure is hazardous, which means that the insulation has to be continuously checked and repaired immediately after detected failure.

Supplementary to other protection devices the IT system normally contains insulation monitoring device (IMD) or system that alarms when insulation resistance or impedance is below set threshold. Threshold value depends on environment. Typical value for medical installations is 55 k Ω .

In some countries it is not enough to trace insulation resistance of IT supply system to the ground, they require tracing of system capacitance, too.

IEC 60364-4-41 (©IEC): In IT systems live parts shall be insulated from earth or connected to earth through sufficiently high impedance. This connection may be made either at the neutral point or at midpoint of the system or at an artificial neutral point. The latter may be connected directly to earth if the resulting impedance to earth is

sufficiently high at the system frequency. Where no neutral point or mid-point exists a line conductor may be connected to earth through high impedance.

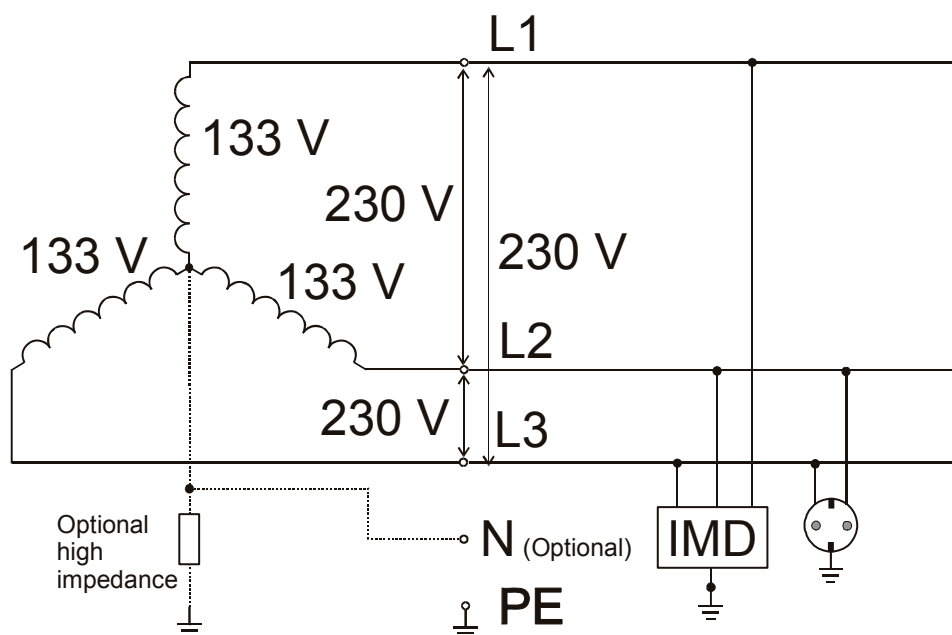

Figure B.1: General IT supply system

- Three phase star connection, optional delta connection.
- Optional neutral line.
- Single-phase connection is also possible.
- Various system voltages – not only three phase 230 V as indicated above.
- One faulty connection of any line to PE is treated as first fault and is regular but it has to be repaired as soon as possible.
- **IEC 60364-4-41**: In IT systems the following monitoring devices and protective devices may be used:
 - Insulation monitoring devices (IMDs),
 - Residual current monitoring devices (RCMs),
 - Insulation fault location systems,
 - Overcurrent protective devices,
 - Residual current protective devices (RCDs).

Note:

- Where a residual current operating device (RCD) is used, tripping of the RCD in the event of a first fault cannot be excluded due to capacitive leakage currents.

Testing of IT supply system is slightly different to standard tests in TN / TT system.

B.3 Measurement guides

The user has to select the IT supply system in the instrument before testing it. The procedure for selecting the IT supply system is defined in chapter 4.5.1 *Supply system setup*. Once the IT system is selected the instrument can be used immediately. The instrument keeps selected IT system when it is turned off.

The table below contains functions of the MI 3102 instrument including compatibility notes related to IT system.

IT system functions	Notes
Continuity functions	
RLOW Ω	Independent of selected supply system.
Continuity	
Insulation	Independent of selected supply system.
Line impedance	
Line impedance	Impedance Z_{L1-L2} .
Prospective short circuit current	I_{PSC} for rated U_{L1-L2} .
Fault loop impedance	Not applicable.
Fault loop impedance	
Prospective fault current	
Voltage, frequency	Symbols modified for IT system.
Phase rotation	Three-phase system automatic detected.
RCD functions	Partially applicable.
Contact voltage U_C	Not applicable.
Trip-out time	Bypassing principle shown in figure B.3.
Trip-out current	
Automatic test	
Earth resistance	Independent of selected supply system.
PE test probe	Active, but does not inhibit selected test if voltage is detected.

B.3.1 Voltage

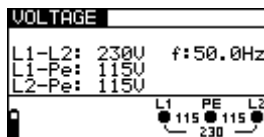

Figure B.2: Example of voltage and frequency measurements

Displayed results for **single phase** system:

L1-L2 Voltage between line conductors,

L1-pe Voltage between line 1 and protective conductor,

L2-pe Voltage between line 2 and protective conductor.

B.3.2 Line impedance

See chapter 5.6 *Line impedance and prospective short-circuit current*, the measurement is the same; only terminal voltage monitor indication corresponds to IT system.

B.3.3 RCD testing

RCD testing is performed in the same way as in TN/TT system (See chapter 5.4 *Testing RCDs*), with the following exception:

- Contact voltage measurement is not relevant.

Test circuit with bypassing principle should correspond to that in figure B.3.

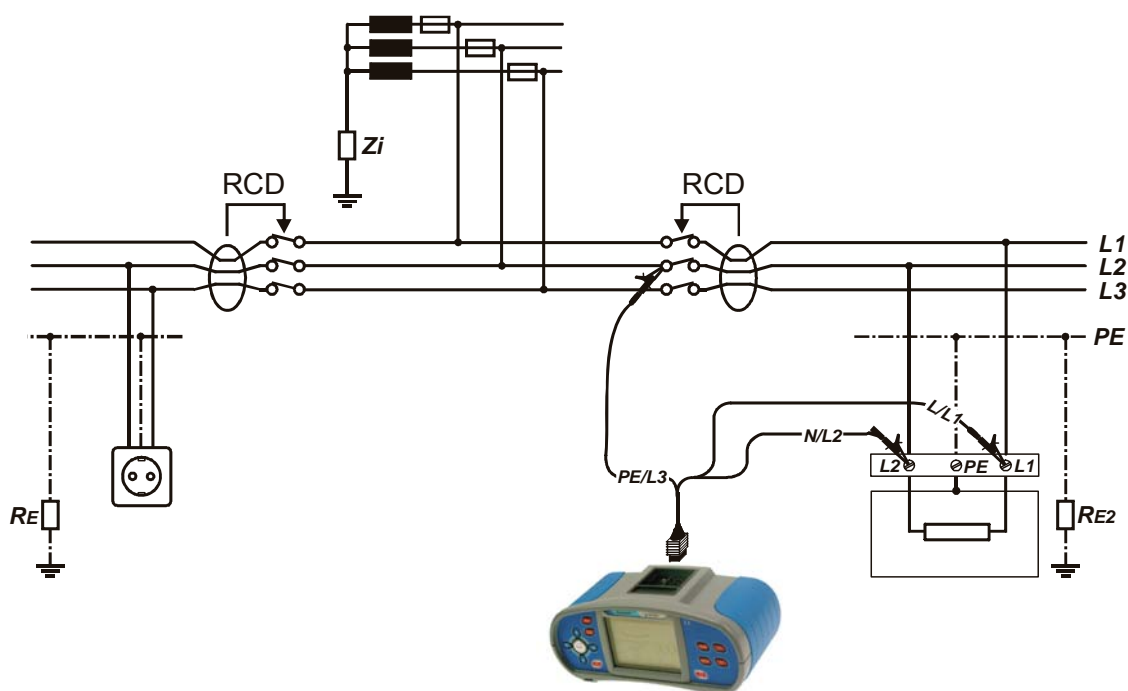

Figure B.3: RCD testing in IT system

B.3.4 First fault leakage current (ISFL) (MI 3102 only)

First fault leakage current measurement is performed in order to verify the maximum current that could leak into PE from observed line. This current flows through the insulation resistance and reactance (capacitance) between the other lines and PE.

How to perform first fault current measurement

Step 1 Select **Insulation** function with the function selector switch first. Use the Δ/∇ keys to select **ISFL (first fault current)** function. The following menu is displayed:



Figure B.4: First fault current measurement menu

Connect test cable to the EurotestXE instrument.

Step 2 Set the following limit value:

- First fault current high limit value.

Step 3 Connect test cable to the item under test. Follow the connection diagram shown in figure B.5 to perform first fault current measurement. Use the **Help** function if necessary.

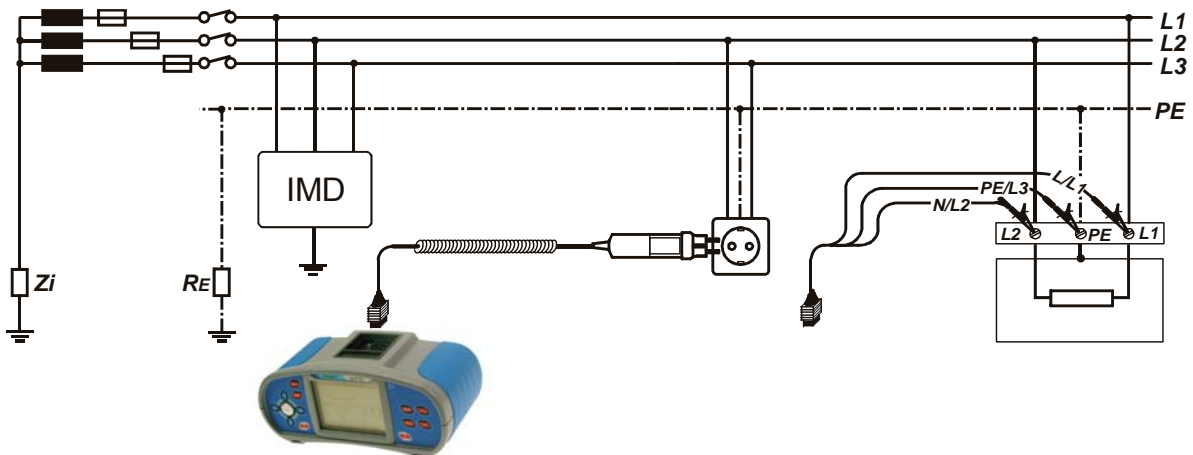

Figure B.5: Connection with plug commander and universal test cable

Step 4 Check the displayed warnings and online voltage/terminal monitor before starting measurement. If OK, press the TEST key. After performing the measurement results appear on the display together with the PASS/FAIL indication (if applicable).

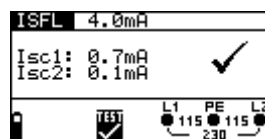

Figure B.6: Example of first fault current measurement results

Displayed results:

I_{SC1}First fault current between L1-PE,
 I_{SC2}First fault current between L2-PE.

Save displayed results for documentation purposes. Refer to chapter 6.1.
Saving results.

B.3.5 Insulation monitoring device testing (MI 3102 only)

How to check insulation monitoring device

Step 1 Select **Insulation** function with the function selector switch first. Use the $\blacktriangle/\blacktriangledown$ keys to select **IMD check** function. The following menu is displayed:

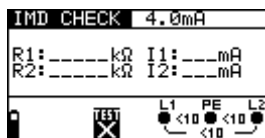

Figure B.7: IMD check menu

Connect test cable to the EurotestXE instrument.

Step 2 Set the following limit value:

- Fault resistance (indicative)
- Calculated first fault current high limit value.

Step 3 Connect test cable to the item under test. Follow the connection diagram shown in figure B.5 to check insulation monitor device. Use the **Help** function if necessary.

Step 4 Check the displayed warnings and online voltage/terminal monitor before starting the measurement. If OK, press the TEST key. Use the $\blacktriangle/\blacktriangledown$ keys to decrease indicative insulation resistance until insulation monitor device alarms bad insulation. Indicative insulation resistance and calculated first fault current between first live conductor (e.g. L1) and PE conductor are displayed. After performing the measurement results with PASS/FAIL indication appear on the display.

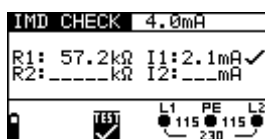

Figure B.8: First fault condition between L1 and PE

Step 5 Use the ∇ key to select second live line (e.g. L2). Use the \leftarrow/\rightarrow keys to decrease indicative insulation resistance until insulation monitor device alarms bad insulation. Indicative insulation resistance and calculated first fault current between second live conductor (e.g. L2) and PE conductor are displayed.

To complete measurement press the TEST key again.

After performing the measurement results with PASS/FAIL indication appear on the display.

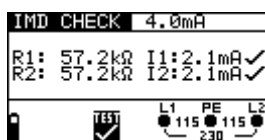

Figure B.8: First fault condition between L2 and PE

Displayed results:

R1 Threshold indicative insulation resistance for L1,

I1 Calculated first fault leakage current at threshold insulation resistance for L1,

R2 Threshold indicative insulation resistance for L2,

I2 Calculated first fault leakage current at threshold indicative insulation resistance for L2.

First fault leakage currents I_1 and I_2 are calculated as follows:

$$I_1 = \frac{U_{L1-L2}}{R_1}, \quad I_2 = \frac{U_{L1-L2}}{R_2}$$

where:

U_{L1-L2} Measured voltage between L1 and L2,

R_1 Threshold insulation resistance for L1,

R_2 Threshold insulation resistance for L2.

The calculated first fault current is the maximum current that would flow when insulation resistance decreases to the same value as the applied test resistance, and a first fault is assumed between opposite line and PE.

Save displayed results for documentation purposes. Refer to chapter 6.1. *Saving results.*

Note:

- It is recommended to disconnect all appliances from the tested supply net to receive regular test results. Any connected appliance will influence the insulation resistance threshold test.
- The displayed resistances and currents are indicative only. Displayed resistance can significantly differ from the actual resistance the Eurotest simulates. If IMD's with very low test currents (below 1mA) are checked the displayed resistance value is typically lower (and current higher) than the actual simulated resistance. The difference is lower for lower set resistances.

B.4 Technical specifications (MI 3102 only)

Only technical specifications that are different to the specifications from chapter 8 of this document are listed below.

B.4.1 First fault leakage current (ISFL)

Measuring range (mA)	Resolution (mA)	Accuracy
0.0 ÷ 9.9	0.1	±(5 % of reading + 3 digits)
10 ÷ 19	1	±(5 % of reading)

Measuring resistance..... approx. 1000 Ω

B.4.2 Calibrated resistances for IMD testing

Test resistance range..... 20 k Ω to 650 k Ω (indicative values), 64 steps

Absolute maximum overload voltage..... 265 V

Calculated insulation leakage current

Measuring range (mA)	Resolution (mA)	Note
0.0 ÷ 19.9	0.1	calculated value

C Reduced low voltage supply systems

C.1 Standard reference

- BS7671

C.2 Fundamentals

Special supply systems are applied where inherent protection to electric shock is required but no SELV used. Reduced low voltage supply with ground reference can be used for this purpose.

There are two options with 110 V nominal voltage.

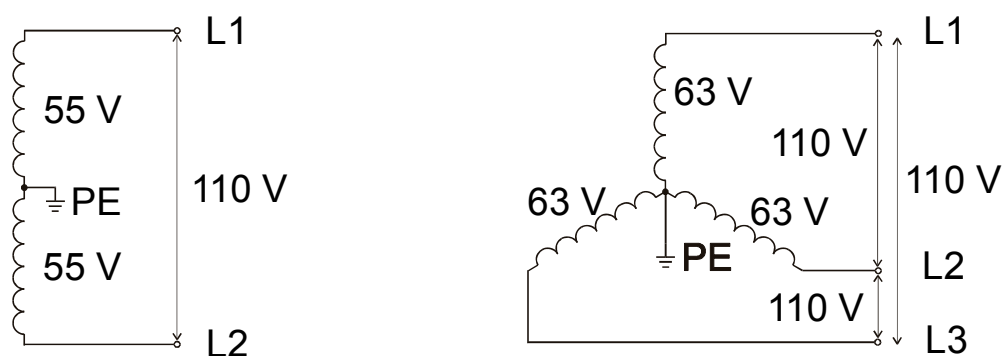

- Single phase with center tap connected to PE (i.e. 2 x 55 V).
- No neutral line.
- Three phase star connection, center tap connected to PE (i.e. 3 x 63 V).
- No neutral line.

Figure C.1: General reduced low voltage supply systems

C.3 Measurement guides

The user has to select the reduced low voltage supply system in the instrument before testing it. The procedure for selecting the reduced low voltage supply system is defined in chapter 4.5.1 *Supply system setup*. Once the reduced low voltage system is selected the instrument can be used immediately. The instrument keeps selected reduced low voltage system when it is turned off.

The table below contains EurotestXE functions intended for test and measurement of supply systems with compatibility notes related to the reduced low voltage system.

Reduced low voltage system functions	Notes
Continuity functions	
RLOW Ω	Independent of selected supply system.
Continuity	
Insulation	Independent of selected supply system.
Line resistance	
Line resistance	Resistance R_{L1-L2} .
Prospective short circuit current	I_{PSC} for $U_{L1-L2} = 110$ V.
Fault loop resistance	
Fault loop resistance	Both fault loops, R_1 (L1-PE) and R_2 (L2-PE).
Prospective fault current	I_{SC1} and I_{SC2} for both fault loops.
Voltage, frequency	Symbols modified for reduced low voltage system.
Phase rotation	Three-phase system automatic detected.
RCD functions	
Contact voltage U_C	For both possibilities, U_1 (L1-PE) and U_2 (L2-PE).
Trip-out time	Maximum nominal differential current limited to 1 A.
Trip-out current	
Automatic test	
Earth resistance	Independent of selected supply system.
PE test probe	Disabled.

C.3.1 Voltage

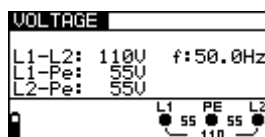

Figure C.2: Example of voltage and frequency measurements

Displayed results for single phase system:

L1-L2 Voltage between line conductors,

L1-pe Voltage between line 1 and protective conductors,

L2-pe Voltage between line 2 and protective conductors.

C.3.2 RCD testing

Maximum regular RCD test current is 1 A r.m.s. (1.4 A peak) and can be achieved only when fault loop resistance is lower than 1 Ω .

Tests are carried out for both combinations (L1-PE and L2-PE) automatically. Each individual test result is accompanied with appropriate indication.

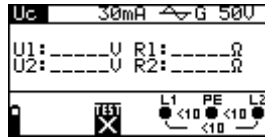



Figure C.3: RCD contact voltage test

C.3.3 Line resistance and prospective short circuit current

Measured resistance represents Line-Line resistance (R_{L1-L2}). Nominal system voltage for calculation of I_{PSC} is set to 110 V.

Nominal system voltage range for line resistance measurement is 90 V to 121 V. If input voltage is out of range it is displayed on terminal voltage monitor, together with the indicator of disabled test .

C.3.4 Fault loop resistance and prospective fault current

Definition of nominal system voltage for calculation of I_{PFC} is changed to:

- 55 V for single-phase center-tap system selected,
- 63 V for three-phase system selected.

Tests can be carried out for both combination L1-PE and L2-PE. Each individual test result is accompanied with appropriate indication.

Nominal input voltages are:

Nominal input voltage U_N	Voltage range
Single-phase 55 V system	(44 V \leq U < 61 V),
Three-phase 63 V system	(56 V \leq U \leq 70 V),

If input voltage is out of range it is displayed on terminal voltage monitor, together with the indicator of disabled test .

C.4 Technical specifications

Only those technical specifications are listed below that are different to specifications from chapter 8 of this document.

C.4.1 RCD testing

General data

Nominal residual current.....	10 mA, 30 mA, 100 mA, 300 mA, 500 mA, 1000 mA
Nominal residual current accuracy....	-0 / +0.1·I _Δ ; I _Δ = I _{ΔN} , 2×I _{ΔN} , 5×I _{ΔN} -0.1·I _Δ / +0; I _Δ = 1/2×I _{ΔN}
Maximum nominal differential current for declared accuracy	1000 mA for I _{ΔN} 500 mA for 2×I _{ΔN} 100 mA for 5×I _{ΔN}
Maximum test current	1 A (for Z LOOP < 1 Ω)
Test current shape.....	Sine-wave (AC), pulsed (A)
DC offset for pulsed test current	6 mA typical
RCD type	general (G, non-delayed), selective (S, time- delayed)
Test current starting polarity	0° or 180°
Nominal input voltage	55 V / 63 V (45 Hz ÷ 65 Hz)

Contact voltage

Measuring range according to EN61557-6 is 3.0 V ÷ 32.6 V for limit contact voltage 25 V.

Measuring range according to EN61557-6 is 3.0 V ÷ 66.0 V for limit contact voltage 50 V.

Measuring range (V)	Resolution (V)	Accuracy
0.0 ÷ 9.9	0.1	(-0 % / +15 %) of reading + 2 digits
10.0 ÷ 99.9	0.1	(-0 % / +15 %) of reading

Accuracy applies for 1 year in reference conditions. Temperature coefficient outside these limits is +1 digit.

Test current max. 0.5×I_{ΔN}

Limit contact voltage 25 V or 50 V

The contact voltage is calculated to.. I_{ΔN} (general type) or to 2×I_{ΔN} (selective type)

Fault loop resistance at contact voltage is calculated as $R_L = \frac{U_C}{I_{\Delta N}}$.

Trip-out time

Complete measurement range corresponds to EN61557-6 requirements. Specified accuracies are valid for complete operating range.

General (non-delayed) RCDs

Measuring range (ms)	Resolution (ms)	Accuracy
0 ÷ 300 ($\frac{1}{2} \times I_{\Delta N}$, $I_{\Delta N}$)	1	±3 ms
0 ÷ 150 ($2 \times I_{\Delta N}$)	1	
0 ÷ 40 ($5 \times I_{\Delta N}$)	1	

Selective (time-delayed) RCDs

Measuring range (ms)	Resolution (ms)	Accuracy
0 ÷ 500 ($\frac{1}{2} \times I_{\Delta N}$, $I_{\Delta N}$)	1	±3 ms
0 ÷ 200 ($2 \times I_{\Delta N}$)	1	
0 ÷ 150 ($5 \times I_{\Delta N}$)	1	

Test current $\frac{1}{2} \times I_{\Delta N}$, $I_{\Delta N}$, $2 \times I_{\Delta N}$, $5 \times I_{\Delta N}$

$5 \times I_{\Delta N}$ is not applicable for $I_{\Delta N} \geq 100$ mA (RCD types AC,A)

$2 \times I_{\Delta N}$ is not applicable for $I_{\Delta N} \geq 500$ mA (RCD type AC) or $I_{\Delta N} \geq 300$ mA (RCD type A)

$I_{\Delta N}$ is not applicable for $I_{\Delta N} = 1000$ mA (RCD type AC) or $I_{\Delta N} \geq 500$ mA (RCD type A)

Trip-out current

Trip-out current ($I_{\Delta N} = 10$ mA)

Measurement range corresponds to EN61557-6 requirements. Specified accuracies are valid for complete operating range.

Measuring range I_{Δ}	Resolution I_{Δ}	Accuracy
$0.2 \times I_{\Delta N} \div 1.1 \times I_{\Delta N}$ (AC type)	$0.05 \times I_{\Delta N}$	$\pm 0.1 \times I_{\Delta N}$
$0.2 \times I_{\Delta N} \div 2.2 \times I_{\Delta N}$ (A type)	$0.05 \times I_{\Delta N}$	$\pm 0.1 \times I_{\Delta N}$

Trip-out current ($I_{\Delta N} \geq 30$ mA)

Measurement range corresponds to EN61557-6 requirements. Specified accuracies are valid for complete operating range.

Measuring range I_{Δ}	Resolution I_{Δ}	Accuracy
$0.2 \times I_{\Delta N} \div 1.1 \times I_{\Delta N}$ (AC type)	$0.05 \times I_{\Delta N}$	$\pm 0.1 \times I_{\Delta N}$
$0.2 \times I_{\Delta N} \div 1.5 \times I_{\Delta N}$ (A type, $I_{\Delta N} \geq 30$ mA)	$0.05 \times I_{\Delta N}$	$\pm 0.1 \times I_{\Delta N}$

Trip-out time

Measuring range (ms)	Resolution (ms)	Accuracy
0 ÷ 300	1	±3 ms

Contact voltage

Measuring range (V)	Resolution (V)	Accuracy
0.0 ÷ 9.9	0.1	(-0 % / +15 %) of reading + 2 digits
10.0 ÷ 99.9	0.1	(-0 % / +15 %) of reading

C.4.2 Fault loop resistance and prospective fault current

R LOOP (Rs in the UK version) sub-function

Measuring range according to EN61557-3 is $0.32 \Omega \div 1999 \Omega$.

Measuring range (Ω)	Resolution (Ω)	Accuracy ^{*)}
0.00 \div 19.99	0.01	$\pm(10\%$ of reading + 5 digits)
20.0 \div 99.9	0.1	
100 \div 1999	1	

^{*)}The accuracy is valid if mains voltage is stable during the measurement.

Prospective fault current (calculated value)

Measuring range (A)	Resolution (A)	Accuracy
0.00 \div 19.99	0.01	Consider accuracy of fault loop resistance measurement
20.0 \div 99.9	0.1	
100 \div 999	1	
1.00k \div 9.99k	10	
10.0 \div 24.4k	100	

IPFC calculation..... $I_{PFC}=U_N \times k_{SC} / Z_{L-PE}$

$U_N = 55 \text{ V}$, ($44 \text{ V} \leq U < 61 \text{ V}$) for selected 55 V single-phase system

$U_N = 63 \text{ V}$, ($56 \text{ V} \leq U < 70 \text{ V}$) for selected 63 V three-phase system

Test current 1.9 A (10 ms)

Nominal input voltage 55 V / 63 V (45 Hz \div 65 Hz)

Test possibilities L1-PE and L2-PE

Rs(rcd) trip-lock sub-function

Measuring range according to EN61557 is $0.85 \Omega \div 1999 \Omega$.

Measuring range (Ω)	Resolution (Ω)	Accuracy ^{*)}
0.00 \div 19.99	0.01	$\pm(10\%$ of reading + 15 digits)
20.0 \div 99.9	0.1	$\pm 10\%$ of reading
100 \div 1999	1	$\pm 10\%$ of reading

^{*)} Accuracy may be impaired in case of heavy noise on mains voltage.

Prospective fault current (calculated value)

Measuring range (A)	Resolution (A)	Accuracy
0.00 \div 19.99	0.01	Consider accuracy of fault loop resistance measurement
20.0 \div 99.9	0.1	
100 \div 999	1	
1.00k \div 9.99k	10	
10.0 \div 24.4k	100	

IPFC calculation..... $I_{PFC}=U_N \times k_{SC} / Z_{L-PE}$

$U_N = 55 \text{ V}$, ($44 \text{ V} \leq U < 61 \text{ V}$) for selected 55 V single-phase system

$U_N = 63 \text{ V}$, ($56 \text{ V} \leq U < 70 \text{ V}$) for selected 63 V three-phase system

Nominal input voltage 55 V / 63 V (45 Hz \div 65 Hz)

Test possibilities L1-PE and L2-PE

No trip out of RCD.

C.4.3 Line resistance and prospective short-circuit current

Line resistance

Measuring range according to EN61557-3 is $0.25 \Omega \div 1999 \Omega$.

Measuring range (Ω)	Resolution (Ω)	Accuracy ^{*)}
0.00 \div 19.99	0.01	$\pm(5\% \text{ of reading} + 5 \text{ digits})$
20.0 \div 99.9	0.1	
100 \div 1999	1	

^{*)}The accuracy is valid if mains voltage is stable during the measurement.

Prospective short-circuit current (calculated value)

Measuring range (A)	Resolution (A)	Accuracy
0.00 \div 19.99	0.01	Consider accuracy of line resistance measurement
20.0 \div 99.9	0.1	
100 \div 999	1	
1.00k \div 9.99k	10	
10.0 \div 24.4k	100	

IPFC calculation..... $I_{PSC} = U_N \times k_{SC} / Z_{L-N}$
 $U_N = 110 \text{ V}, (90 \text{ V} \leq U < 121 \text{ V})$
 Test current 3.1 A (10 ms)
 Nominal input voltage 110 V (45 Hz \div 65 Hz)

D Accessories required for specific measurement

The table below presents standard and optional accessories required for specific measurement. The accessories marked as optional may also be standard ones in some set configurations. Please see attached list of standard accessories for your set configuration or contact your distributor for further information.

Function	Suitable accessories
Insulation	<input type="checkbox"/> Universal test cable (A1011) <input type="checkbox"/> Tip commander MI 3100, MI 3002 (A1175) <input type="checkbox"/> Tip commander MI 3102 (A1176)
Continuity	<input type="checkbox"/> Universal test cable (A1011) <input type="checkbox"/> Tip commander MI 3100, MI 3002 (A1175) <input type="checkbox"/> Tip commander MI 3102 (A1176) <input type="checkbox"/> Probe test lead 4m (A1154)
Continuity 7mA	<input type="checkbox"/> Universal test cable (A1011) <input type="checkbox"/> Tip commander MI 3100, MI 3002 (A1175) <input type="checkbox"/> Tip commander MI 3102 (A1176)
Line impedance	<input type="checkbox"/> Universal test cable (A1011) <input type="checkbox"/> Plug commander MI 3100, MI 3002 (A1168) <input type="checkbox"/> Plug commander MI 3102 (A1170) <input type="checkbox"/> Plug cable (schuko) (A1053) <input type="checkbox"/> Plug cable (UK) (A1054)
Fault loop impedance Z LOOP Zs (rcd)	<input type="checkbox"/> Universal test cable (A1011) <input type="checkbox"/> Plug commander MI 3100, MI 3002 (A1168) <input type="checkbox"/> Plug commander MI 3102 (A1170) <input type="checkbox"/> Plug cable (schuko) (A1053) <input type="checkbox"/> Plug cable (UK) (A1054)
RCD testing Contact voltage Trip-out time Trip-out current Autotest	<input type="checkbox"/> Universal test cable (A1011) <input type="checkbox"/> Plug commander MI 3100, MI 3002 (A1168) <input type="checkbox"/> Plug commander MI 3102 (A1170) <input type="checkbox"/> Plug cable (schuko) (A1053) <input type="checkbox"/> Plug cable (UK) (A1054)
Phase sequence	<input type="checkbox"/> Universal test cable (A1011) <input type="checkbox"/> Three-phase cable (A 1110) <input type="checkbox"/> Three-phase adapter (A 1111)
Voltage, frequency	<input type="checkbox"/> Universal test cable (A1011) <input type="checkbox"/> Plug commander MI 3100, MI 3002 (A1168) <input type="checkbox"/> Plug commander MI 3102 (A1170) <input type="checkbox"/> Plug cable (schuko) (A1053) <input type="checkbox"/> Plug cable (UK) (A1054) <input type="checkbox"/> Tip commander MI 3100, MI 3002 (A1175) <input type="checkbox"/> Tip commander MI 3102 (A1176)
Resistance to earth (MI 3102 only)	Earth test set – 20 m: <input type="checkbox"/> Test lead, black 20 m (A1025) <input type="checkbox"/> Test lead, green, 20 m (A1177) <input type="checkbox"/> Test lead, blue, 4.5 m (A1178) <input type="checkbox"/> Earth test rod (A1022)
Sensor (MI 3102 only)	<input type="checkbox"/> LUXmeter probe, type B (A1172) <input type="checkbox"/> LUXmeter probe, type C (A1173)
TRMS current (MI 3102 only)	<input type="checkbox"/> Current clamp, 0.5 mA ÷ 20 A (A1018) <input type="checkbox"/> Current clamp, 0.2 A ÷ 20 A (A1019) <input type="checkbox"/> Mini current clamp, 0.2 A ÷ 20 A (A1074) and connection leads for mini current clamp (S 2025)