



Artisan Technology Group is your source for quality new and certified-used/pre-owned equipment

- FAST SHIPPING AND DELIVERY
- TENS OF THOUSANDS OF IN-STOCK ITEMS
- EQUIPMENT DEMOS
- HUNDREDS OF MANUFACTURERS SUPPORTED
- LEASING/MONTHLY RENTALS
- ITAR CERTIFIED SECURE ASSET SOLUTIONS

SERVICE CENTER REPAIRS

Experienced engineers and technicians on staff at our full-service, in-house repair center

*InstraView*SM REMOTE INSPECTION

Remotely inspect equipment before purchasing with our interactive website at www.instraview.com ↗

WE BUY USED EQUIPMENT

Sell your excess, underutilized, and idle used equipment. We also offer credit for buy-backs and trade-ins. www.artisanng.com/WeBuyEquipment ↗

LOOKING FOR MORE INFORMATION?

Visit us on the web at www.artisanng.com ↗ for more information on price quotations, drivers, technical specifications, manuals, and documentation

Contact us: (888) 88-SOURCE | sales@artisanng.com | www.artisanng.com

Dual Trace Oscilloscope

GOS-630FC

USER MANUAL

GW INSTEK PART NO. 82OS-630FCMA1



ISO-9001 CERTIFIED MANUFACTURER

GW INSTEK

This manual contains proprietary information, which is protected by copyrights. All rights are reserved. No part of this manual may be photocopied, reproduced or translated to another language without prior written consent of Good Will company.

The information in this manual was correct at the time of printing. However, Good Will continues to improve products and reserves the rights to change specification, equipment, and maintenance procedures at any time without notice.

Good Will Instrument Co., Ltd.
No. 7-1, Jhongsing Rd., Tucheng City, Taipei County 236, Taiwan.

Table of Contents

SAFETY INSTRUCTIONS 5

PRODUCT OVERVIEW..... 10

Product Description 10

Main Features 11

Block Diagram 12

PANEL OVERVIEW 13

Front Panel Overview 13

Display Controls 14

LCD Display 15

Horizontal Controls 16

Vertical Controls 17

Trigger Controls 19

Input Terminals..... 22

Rear Panel Overview 23

SETUP..... 24

Default Settings 24

Set up & Probe Compensation 26

MEASUREMENT..... 28

Single Channel (Basic) Measurement .. 28

Dual Channel Measurement..... 29

Waveform Addition/Subtraction..... 31

Frequency Measurement 31

X-Y Mode 32

Waveform Magnification 33

FAQ 34

APPENDIX 36

Line Voltage & Fuse Replacement 36

Specifications 38







Declaration of Conformity..... 40

S SAFETY INSTRUCTIONS

This chapter contains important safety instructions that you must follow when operating the instrument and when keeping it in storage. Read the following instructions before operating the instrument to ensure your safety and to keep it in best condition.

Safety symbols

These safety symbols may appear in this manual or on the instrument.

	WARNING	Warning: Identifies conditions or practices that could result in injury or loss of life.
	CAUTION	Caution: Identifies conditions or practices that could result in damage to the instrument or to other properties.
		DANGER: High Voltage
		Attention: Refer to the Manual
		Protective Conductor Terminal
		Earth (Ground) Terminal

Safety guidelines

General Guideline



CAUTION

- Never connect a hazardous live voltage to the ground side of the BNC connectors. It might lead to fire or electric shock.
- Do not place heavy objects on the instrument.
- Avoid severe impacts or rough handlings that lead to damaging the instruments.
- Do not discharge static electricity onto the instruments.
- Use only mating connectors, not bare wires, for the terminals.
- Do not block the cooling fan opening.
- Do not perform measurements at power generating sources and building installation sites (See note below).
- Do not disassemble the instrument unless you are technically qualified.
- To prevent a permanent damage to the CRT phosphor, avoid excessively brightening the trace or holding a light spot for an unreasonably long time.
- Do not operate the instrument in a place where strong magnetic or electric field exists as it may disturb the measurement.
- Make sure the input voltage does not exceed the following values.

Input Terminal	Maximum Input Voltage
----------------	-----------------------

CH1, CH2 input	300Vpeak
----------------	----------

EXT TRIG input	300Vpeak
----------------	----------

Probe input 600Vpeak

Z AXIS input 30Vpeak

(Measurement categories) EN 61010-1:2001 specifies the measurement categories and their requirements as follows. The GOS-630FC falls under category II.

- Measurement category IV is for measurements performed at the source of low-voltage installations.
- Measurement category III is for measurements performed in building installations.
- Measurement category II is for measurements performed on the circuits directly connected to low voltage installations.
- Measurement category I is for measurements performed on circuits not directly connected to mains.

Power Supply



WARNING

- AC Input voltage: 115V/230V AC, 50/60Hz
- The power supply voltage should not fluctuate more than 15%.
- To avoid electric shock, connect the protective grounding conductor of the AC power cord to an earth ground.

Fuse



WARNING

- Fuse type: T0.63A/250V (AC 115V), T0.315A/250V (AC230V)
- Make sure the correct type of fuse is installed before power up.
- To ensure fire protection, replace the fuse only with the specified type and rating.
- Disconnect the power cord before fuse replacement.
- Make sure the cause of fuse blowout is fixed before replacing the fuse.

Cleaning the instrument

- Disconnect the power cord before cleaning the instrument.
- Use a soft cloth dampened in a solution of mild detergent and water. Do not spray any liquid into the instrument.
- Do not use chemicals containing harsh products such as benzene, toluene, xylene, and acetone.

Operation Environment

- Location: Indoor, no direct sunlight, dust free, almost non-conductive pollution (See note below)
- Relative Humidity: < 85%, non-condensing
- Altitude: < 2000m
- Temperature: 0°C to 40°C

(Pollution Degree) EN 61010-1:2001 specifies the pollution degrees and their requirements as follows. The GOS-630FC falls under degree 2.

Pollution refers to “addition of foreign matter, solid, liquid, or gaseous (ionized gases), that may produce a reduction of dielectric strength or surface resistivity”.

- Pollution degree 1: No pollution or only dry, non-conductive pollution occurs. The pollution has no influence.
- Pollution degree 2: Normally only non-conductive pollution occurs. Occasionally, however, a temporary conductivity caused by condensation must be expected.
- Pollution degree 3: Conductive pollution occurs, or dry, non-conductive pollution occurs which becomes conductive due to condensation which is expected. In such conditions, equipment is normally protected against exposure to direct sunlight, precipitation, and full wind pressure, but neither temperature nor humidity is controlled.

Storage environment

- Location: Indoor
- Relative Humidity: < 70%
- Temperature: -10°C to 70°C

Power cord for the United Kingdom

When using the instrument in the United Kingdom, make sure the power cord meets the following safety instructions.

NOTE: This lead/appliance must only be wired by competent persons

! WARNING: THIS APPLIANCE MUST BE EARTHED

IMPORTANT: The wires in this lead are coloured in accordance with the following code:

- Green/ Yellow: Earth
- Blue: Neutral
- Brown: Live (Phase)



As the colours of the wires in mains leads may not correspond with the colours marking identified in your plug/appliance, proceed as follows:
The wire which is coloured Green & Yellow must be connected to the Earth terminal marked with the letter E or by the earth symbol \oplus or coloured Green or Green & Yellow.

The wire which is coloured Blue must be connected to the terminal which is marked with the letter N or coloured Blue or Black.

The wire which is coloured Brown must be connected to the terminal marked with the letter L or P or coloured Brown or Red.

If in doubt, consult the instructions provided with the equipment or contact the supplier.

This cable/appliance should be protected by a suitably rated and approved HBC mains fuse: refer to the rating information on the equipment and/or user instructions for details. As a guide, cable of 0.75mm² should be protected by a 3A or 5A fuse. Larger conductors would normally require 13A types, depending on the connection method used.

Any moulded mains connector that requires removal /replacement must be destroyed by removal of any fuse & fuse carrier and disposed of immediately, as a plug with bared wires is hazardous if a engaged in live socket. Any re-wiring must be carried out in accordance with the information detailed on this label.

P RODUCT OVERVIEW

Product Description

The GOS-630FC oscilloscope is a portable, dual-channel oscilloscope. The GOS-630FC provides maximum 30MHz DC bandwidth and 1mV/DIV sensitivity. Its time base reaches 0.2μS/DIV and the sweep speed 100nS/DIV. The GOS-630FC uses a 6-inch rectangular cathode ray tube display with red internal graticule. This is a sturdy, easy-to-operate, and highly reliable product. The GOS-630FC also incorporates a separate LCD Display, which can show CH1/CH2 VOLT/DIV, TIME/DIV, X-Y MODE, and Frequency.

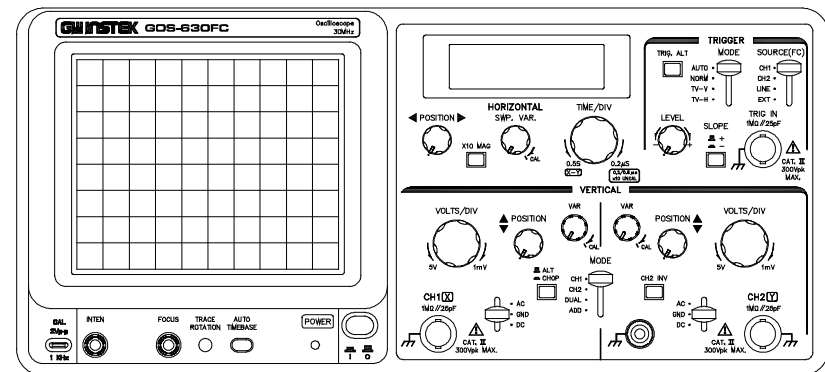

Main Features

High intensity and acceleration CRT	The CRT incorporates high beam transmission, high intensity, and a 2kV high acceleration voltage. The CRT displays clearly readable traces even at higher sweep speeds.
Wide bandwidth and sensitivity	In addition to the DC-30MHz (-3dB) wide bandwidth, the oscilloscope provides a 1mV/DIV high sensitivity. The 30MHz frequency range is obtained by an improved triggering synchronization.
Frequency Counter	A built-in 5-digit frequency counter offers ±0.02% accuracy between 1kHz and 30MHz, and ±0.05% between 50Hz and 1kHz.
Automatic timebase adjustment	Pressing the AUTO TIMEBASE key automatically adjusts the sweep time to an appropriate range.
Alternate triggering	Even when observing two waveforms in different frequencies, both waveforms can be stably triggered using the alternate triggering mode.
TV sync triggering:	The oscilloscope has a sync separator circuit for the TV-V and TV-H signal triggering.
CH1 output	The CH1 signal is output from a rear panel terminal, which can be applied to external devices.
Z-axis input	Display intensity can be controlled via the TTL compatible z-axis input on the rear panel.
X-Y mode	The X-Y mode compares the CH1 and CH2 signal amplitude. It is useful for comparing the phase difference.
Buzzer alarm	Incorrect operation generates a warning beep.

Block Diagram

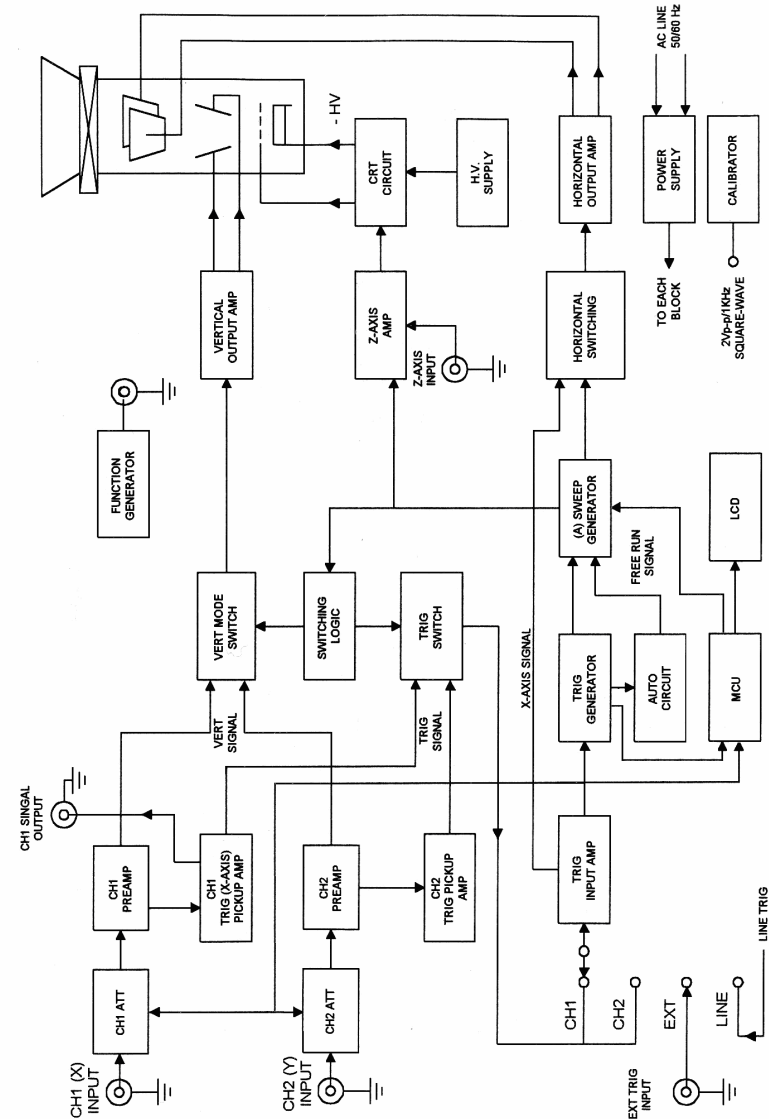

PANEL OVERVIEW

Front Panel Overview

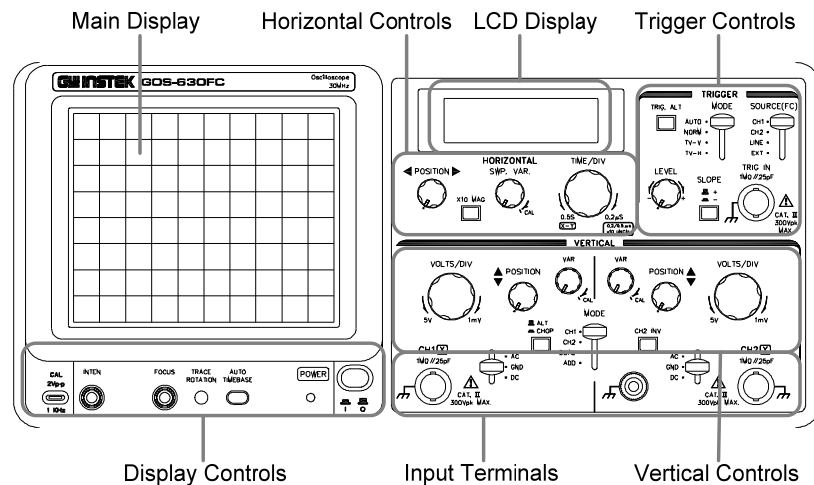

Detailed descriptions of each block start from the next page.

Main Display	Shows the waveforms of input signals.
Display Controls	Controls power on/off, display configuration, and the probe compensation output.
LCD Display	Shows the vertical scale, horizontal scale, X-Y display mode, and waveform frequencies.
Horizontal Controls	Controls the horizontal scale, horizontal position, sweep length, and x10 magnification.

Vertical Controls	Controls the vertical scale, vertical position, display mode, CH2 inversion, and alternate display mode.
Trigger Controls	Controls the trigger mode, trigger level, trigger coupling source, trigger slope, and alternate triggering mode. Accepts the external trigger input.
Input Terminals	Accepts the CH1 and CH2 input signals and ground wire. Controls the input signal coupling mode.

Display Controls

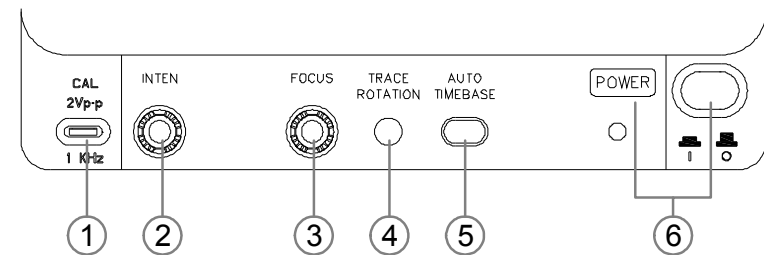

1 CAL Output	Generates the probe compensation signal; 2Vp-p, 1kHz, positive square wave. For probe compensation details, see page26.
2 INTEN Knob	Controls the brightness of a light spot or trace in the display.
3 FOCUS Knob	Controls the focus (sharpness) of the waveforms in the display.
4 TRACE ROTATION Point	Controls the alignment of the horizontal trace in parallel with graticule lines.
5 AUTO TIMEBASE Key	Automatically adjusts the horizontal scale to an appropriate range according to the input signal.
6 POWER Switch	Turns on or off the oscilloscope's main power. When the power is on, the LED lights.

LCD Display

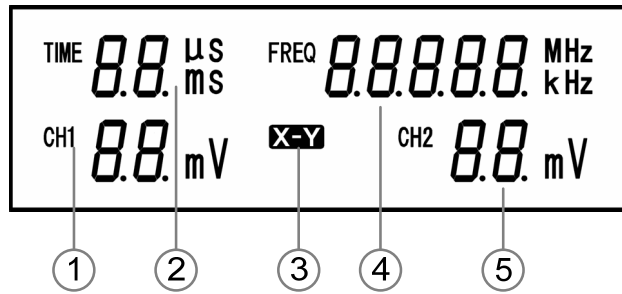

1	CH1 Vertical Scale	Shows the CH1 vertical scale.
2	Horizontal Scale	Shows the horizontal scale.
3	X-Y Mode	When turned on, indicates that the X-Y mode is activated. For X-Y mode details, see page32.
4	Signal Frequency	Shows the waveform frequency. For frequency measurement details, see page31.
5	CH2 Vertical Scale	Shows the CH2 vertical scale.

Horizontal Controls

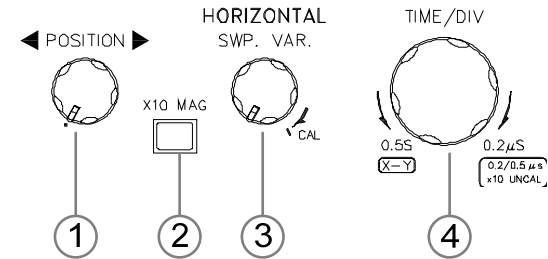

1	Horizontal Position Knob	Controls the horizontal position of traces and light spots.
2	×10 MAG Switch	Magnifies the horizontal scale by a factor of 10. For horizontal magnification details, see page33.
3	SWP VAR Knob	Adjusts the horizontal scale. At the minimum position, the horizontal scale becomes 2.5 times wider than the original value selected by the TIME/DIV knob. For example, if the original scale is 1mS/DIV, the adjusted scale becomes 2.5mS/DIV. At the maximum (CAL) position, there is no change in the horizontal scale.
4	TIME/DIV Knob	Controls the horizontal scale from 0.2 μs/div to 0.5 s/div in 20 steps. When “X-Y” is selected, the oscilloscope works in the X-Y mode. For X-Y mode details, see page32.

Vertical Controls

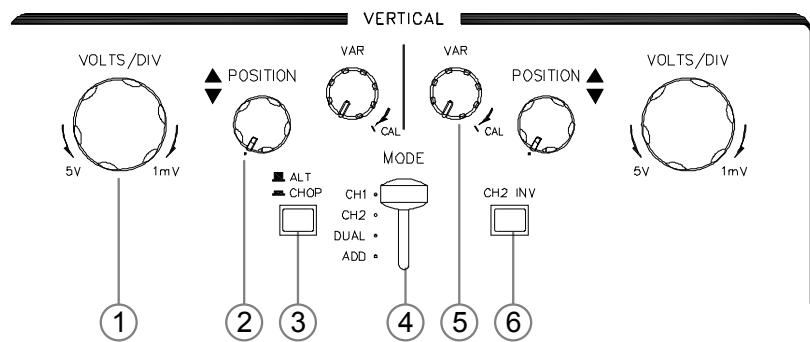

1 VOLTS/DIV Knob Controls the CH1/CH2 vertical scale from 1mV/DIV to 5V/DIV in 12 steps.

2 Vertical POSITION Knob Controls the vertical position of traces and light spots for CH1/CH2.

3 ALT/CHOP Switch Selects how the CH1 and CH2 signals appear in the display, in the DUAL trace mode.

CHOP The two signals are chopped and displayed simultaneously (generally used in slow sweep, 1ms/DIV or slower).

ALT The two signals are displayed alternatively (generally used in fast sweep, 0.5ms/DIV or faster).

4 Vertical MODE Switch Selects CH1 and CH2 display modes.

CH1/CH2 The CH1 or CH2 signal is displayed independently.

DUAL The CH1 and CH2 signals are displayed simultaneously.

ADD The CH1 and CH2 signals are added or subtracted, and then the result is displayed. For CH1/CH2 addition/subtraction details, see page31.

5 VAR Knob Adjusts the vertical scale.

At the minimum position, the vertical scale becomes 2.5 times wider than the original value selected by the VOLTS/DIV knob. For example, if the original scale is 1mV/DIV, the adjusted scale becomes 2.5mV/DIV.

At the maximum (CAL) position, there is no change in the vertical scale.

6 CH2 INV Switch Inverts the CH2 input signal vertically. When the vertical mode switch is in the ADD position, CH2 is subtracted from CH1 instead of being added to CH1. For CH1/CH2 addition/subtraction details, see page31.

Trigger Controls

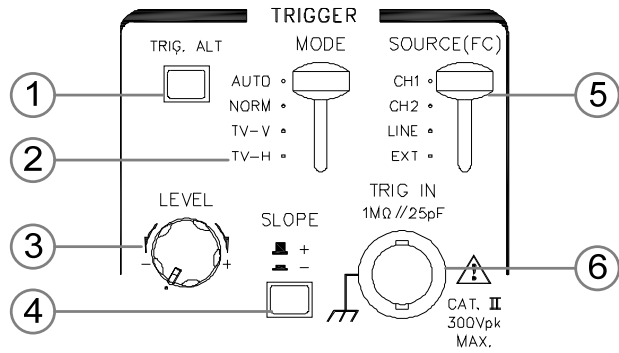

1 Trigger ALT Switch When pressed, the TRIG ALT switch constantly toggles the trigger source between CH1 and CH2 signal, so that both signals can be clearly viewed.

The TRIG ALT switch works when the vertical mode is in the DUAL position and also the trigger source is in the CH1 or CH2 position.

Note

- The TRIG ALT switch does not work when the ALT/CHOP switch is in the CHOP position.
- The frequency counter in the LCD display does not work when the TRIG ALT switch is pressed.

2 Trigger MODE Switch The TRIGGER MODE switch selects when the oscilloscope responds to the trigger conditions.

AUTO The oscilloscope sweeps regardless of the existence of trigger conditions.

NORM The oscilloscope sweeps only when a trigger condition occurs.

TV-V The oscilloscope triggers when a vertical video synchronization signal appears. For triggering on the field, select 2ms/DIV as the horizontal scale; for triggering on the frame (two interlaced fields), 5ms/DIV.

TV-H The oscilloscope triggers when a horizontal video synchronization signal appears. For triggering on the line, select 10us/DIV as the horizontal scale. Use the SWP VAR knob to control the number of waveforms.

Note

- For TV-V and TV-H trigger, the oscilloscope responds only to negative polarity signals.



- The oscilloscope cannot trigger input signals when their frequencies are less than 25Hz.

3 Trigger LEVEL Knob Changes the trigger level vertically. The trigger level moves up when the trigger LEVEL knob is turned clockwise. The trigger level moves down when the trigger LEVEL knob is turned counterclockwise.

4 Trigger SLOPE Switch Selects the triggering slope.

When in the “+” position (), the oscilloscope triggers when the positive slope of the trigger source signal crosses the trigger level.

When in the “-” position (), the oscilloscope triggers when the negative slope of the trigger source signal crosses the trigger level.

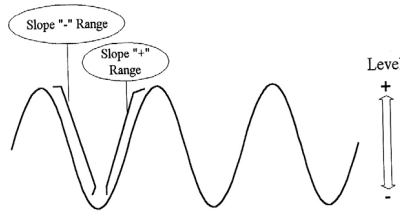

5 Trigger SOURCE Switch	Selects the signal on which the oscilloscope sweeps.	
	CH1	CH1 signal becomes the trigger source.
	CH2	CH2 signal becomes the trigger source.
	LINE	AC power line signal becomes the trigger source. Useful when the input signal synchronizes with the power line frequency.
	EXT	The external trigger input (TRIG IN terminal) signal becomes the trigger source.

6 TRIG IN Terminal Accepts an external trigger source signal. The signal becomes active when the trigger SOURCE switch is in the EXT position.

Input impedance: 1MΩ // 25pF

Input Terminals

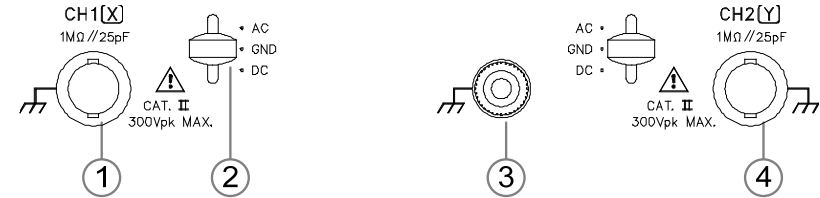

1 CH 1 (X) Input Terminal	Accepts the CH1 input signal. In X-Y mode, the CH1 input signal becomes the X-axis.
2 AC/GND/DC Switch	<p>Selects the coupling mode for the input signal.</p> <p>AC The oscilloscope block DC components included in the input signal.</p> <p>GND Shows the ground (zero volt) level on the display. This mode is only for checking the reference level; input signal does not appear on the display.</p> <p>DC The oscilloscope displays all of the input signal.</p>
3 GND Terminal	Accepts a ground wire. The GND terminal is connected to the oscilloscope mainframe.
4 CH 2 (Y) Input Terminal	Accepts the CH2 input signal. In X-Y mode, the CH2 input signal becomes the Y-axis.

- For X-Y mode details, see page32.

Rear Panel Overview

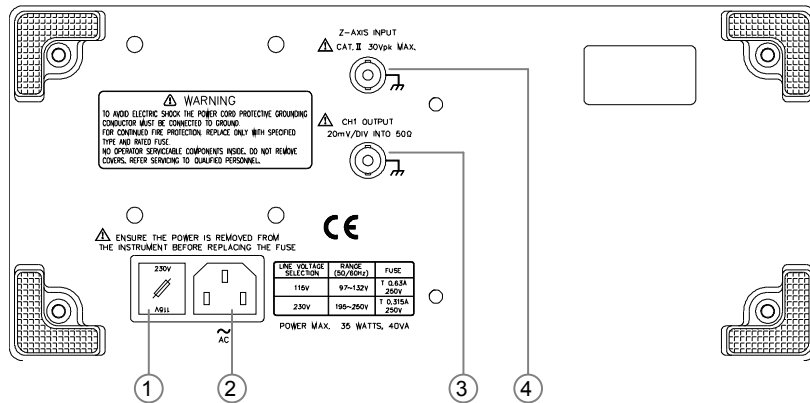









- 1 **FUSE & Line Voltage Selector** Holds the AC mains fuse and selects the AC line voltage, 115V or 230V.
 - 2 **AC Power Input Connector** Accepts the AC power cord.
 - 3 **CH1 OUTPUT Terminal** Outputs the CH1 signal; approximately 20mV/DIV when terminated with 50Ω.
 - 4 **Z AXIS INPUT Terminal** Accepts an external intensity modulation (Z-axis) signal; 1kHz square wave, DC – 2MHz. Positive going reduces intensity. For detailed specifications, see page38.
- For AC line voltage selection and fuse replacement, see page36.

SETUP

Default Settings

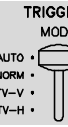
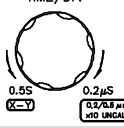

Before powering up the oscilloscope, set up the front panel as follows.

- POWER Switch** Off
- INTEN Knob** Center
- FOCUS Knob** Center
- Vertical MODE Switch** CH1
- ALT/CHOP Switch** ALT (■)
- CH 2 INV Switch** Released (Inversion disabled)
- CH1 /CH2 Vertical POSITION Knob** Center of the display
- CH1 /CH2 VOLTS/DIV Knob** 50mV/DIV

CH1/CH2 VARIABLE Knob		CAL
CH1/CH2 Coupling Switch		AC
Trigger SOURCE Switch		CH1
Trigger SLOPE Switch		+ (Positive slope)
TRIG ALT Switch		Released (alternating trigger disabled)
Trigger MODE Switch		AUTO
TIME/DIV Knob		0.5ms/DIV
Horizontal SWP.VAR Knob		CAL
Horizontal POSITION Knob		Center of the display
x10 MAG Switch		Released (x10 magnification disabled)

Set up & Probe Compensation

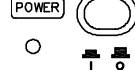
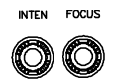
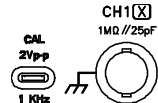
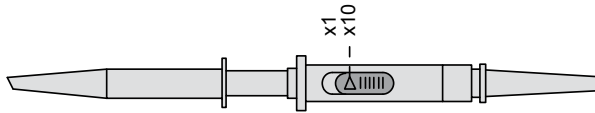
Follow these steps and properly set up the oscilloscope, make sure it is functional, and compensate the probe.

- Power on** Press the Power switch and turn on the oscilloscope's power. The LED lights when the power is on. The trace line starts to appear after 20 – 30 seconds.
 
- Intensity and focus adjustment** Use the INTEN knob and FOCUS knob to adjust the trace line appearance to the best condition.
 
- Probe connection** Connect the probe between the CAL output and the CH1 input terminal. Select x10 (attenuation) on the probe.
 
- Probe attenuation** Select x10 (attenuation) on the probe.
 
- Coupling mode selection** Select the AC position in the CH1 AC-DC-GND switch. A square waveform appears in the display.
 

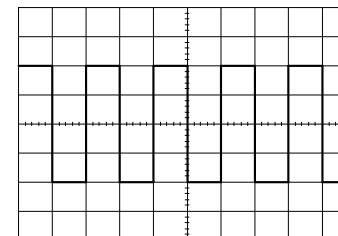

6 Vertical adjustment

Use the CH1 VOLTS/DIV knob and CH1 vertical POSITION knob to adjust the vertical scale and position of the waveform.

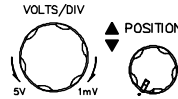

7 Horizontal adjustment

Use the CH1 TIME/DIV knob and CH1 horizontal POSITION knob to adjust the horizontal scale and position of the waveform.

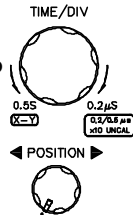

8 Probe compensation

Adjust the compensation point on the probe so that the waveform becomes square.

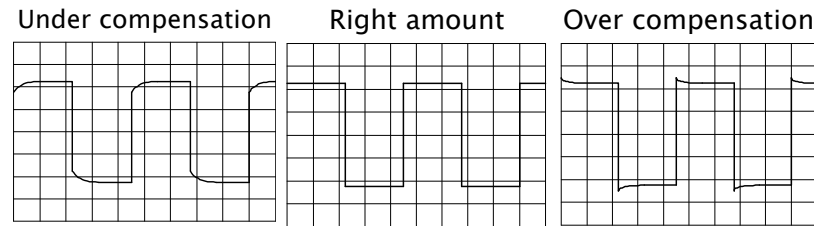
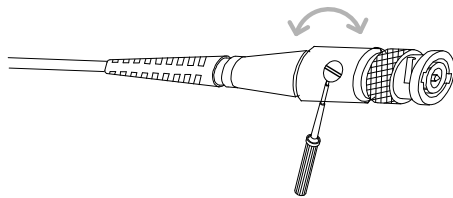

9 Completion

Now setting up the oscilloscope is completed. For more advanced measurements, see page28.

M EASUREMENT

Single Channel (Basic) Measurement

Steps

1. Connect the input signal to the CH1 or CH2 terminal.



2. Select the vertical coupling between AC (DC components are blocked) or DC (all signal components appear).



3. Configure the trigger settings. For details, see page19.

4. Use the VOLTS/DIV knob and vertical POSITION knob to adjust the vertical scale and position of the waveform.

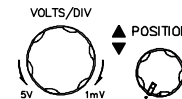

5. Press the AUTO TIMEBASE key to automatically adjust the horizontal scale according to the input signal.



6. If necessary, use the TIME/DIV knob to adjust the horizontal scale manually. Use the horizontal POSITION knob to adjust the position of the waveform.

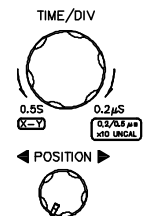

Dual Channel Measurement

Steps

1. Connect both CH1 and CH2 signals to the input terminals.

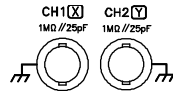

2. Select the vertical coupling between AC (DC components are blocked) or DC (all signal components appear) for both channels.



3. Configure the trigger settings. For details, see page 19. Make sure the trigger SOURCE switch is in either the CH1 or CH2 position.

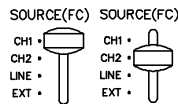

4. Set the vertical MODE switch to the DUAL position.

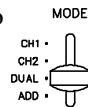

5. Both the CH1 and CH2 signals appear on the display.

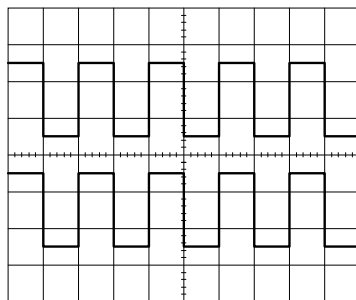

6. Use the vertical ALT/CHOP switch to select how the two waveforms appear on the display: alternately (ALT mode) or simultaneously (CHOP mode). See page 17 for details.



7. If necessary, use the VOLTS/DIV knob and vertical POSITION knob to adjust the vertical scale and position of the waveform.

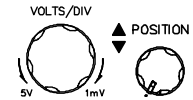

8. If necessary, use the TIME/DIV knob and horizontal POSITION knob to adjust the horizontal scale and position of the waveform.

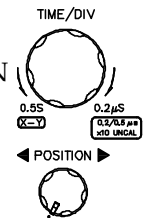

Note



The trigger ALT switch does not work when the ALT/CHOP switch is in the CHOP position.



Waveform Addition/Subtraction

Steps

1. Make sure both CH1 and CH2 waveforms appear on the display. For details, see page 29.

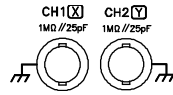

2. Set the vertical MODE switch to the ADD position. The two waveforms are added and appear on the display as a single waveform.

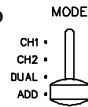

3. To subtract the CH2 signal from the CH1 signal, invert the CH2 signal by pressing the CH2 INV switch.



Frequency Measurement

Frequency shown on the LCD

The frequency of the input signal appears on the LCD display and is constantly updated.

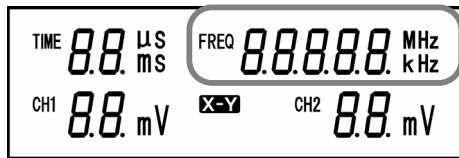

Frequency measurement using the CH1 output

The CH1 signal frequency can be measured using an external device such as frequency counter, via the rear panel terminal.

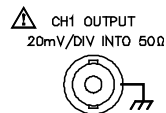

X-Y Mode

Background

The X-Y mode compares the amplitude of two signals (CH1 and CH2), one as X-axis (CH1) and the other as Y-axis (CH2). The X-Y mode is useful for measuring the phase difference of two signals, video color patterns, and frequency response.

Steps

1. Make sure both CH1 and CH2 waveforms appear on the display. For details, see page 29.

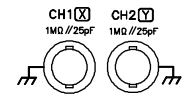

2. Move the TIME/DIV knob to the X-Y position.

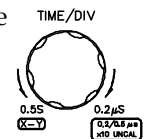

3. The CH1 and CH2 signals appear in the X-Y mode and the X-Y indicator in the LCD display (X-Y) turns on.

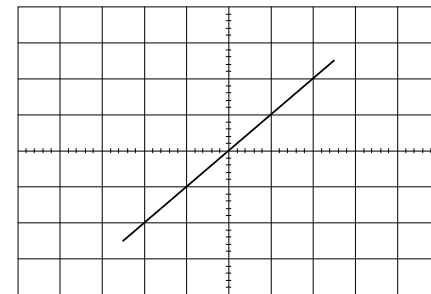

4. To adjust the X-axis position and deflection, use the horizontal POSITION knob (position) and CH1 VOLTS/DIV knob (deflection).

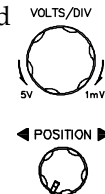

- To adjust the Y-axis position and deflection, use the CH2 vertical POSITION knob (position) and CH2 VOLTS/DIV knob (deflection).

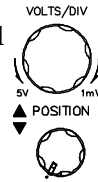

Waveform Magnification

Background The oscilloscope can magnify the waveform by ten times in the horizontal direction. The magnification is useful for observing complex signals.

- Steps**
- Make sure the waveform is shown on the display.
 - Press the $\times 10$ MAG switch. The waveform becomes magnified by ten times in the horizontal direction.

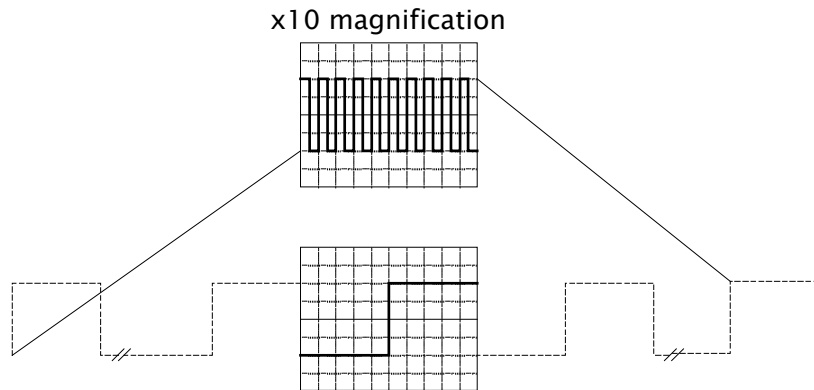

Any part can be covered by using the POSITION control

FAQ

The probe waveform is distorted.

You might need to compensate the probe. For details, see page26. Note that frequency accuracy and duty factor are not specified for the probe compensation waveform and therefore it should not be used for reference purpose.

The trace line does not appear on the display.

Make sure that the trigger mode is in the AUTO mode. In the NORMAL mode, the trace does not appear unless a trigger condition occurs.

The alternate trigger (TRIG ALT switch) does not work.

Make sure that the ALT/CHOP switch is released (ALT position). The TRIG ALT switch does not work in the CHOP mode.

The frequency counter in the LCD display does not work.

Make sure that the TRIG ALT switch is not pressed. The frequency counter does not work in the alternate trigger mode.

The TV trigger does not work.

Make sure that the video synchronization signal is positive. The TV-V/TV-H trigger works only when the synchronization signal is negative.

The input signal does not appear on the display.

Check the following settings.

- The coupling mode is not set at the GND mode, in which the waveform does not appear on the display. See page22 for details.
- The appropriate trigger source is selected. See page19 for details.

The oscilloscope accuracy does not match the specifications.

Make sure the oscilloscope is powered on for at least 30 minutes, within +20°C – +30°C. This is necessary to stabilize the oscilloscope.

For more information, contact your local dealer, Good Will Instruments website www.gwinstek.com.tw, or marketing@goodwill.com.tw.

APPENDIX

Line Voltage & Fuse Replacement

1. Take off the power cord.

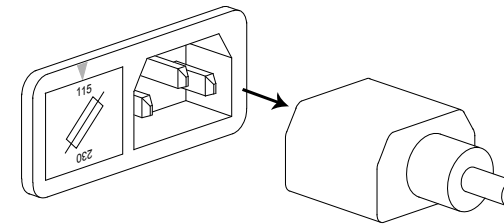

2. Use a small minus driver and pull out the fuse socket.

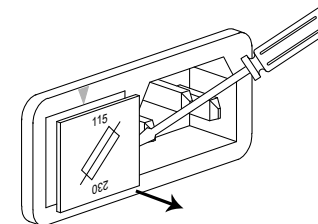

3. Rotate the holder so that the target voltage marking moves to the upper side.

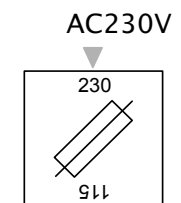
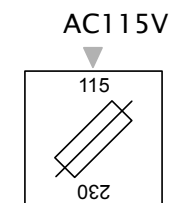
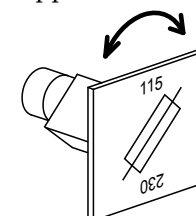

- If necessary, replace the fuse that is attached to the fuse holder.

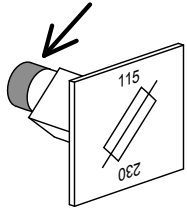

- Push the fuse holder back into the socket.

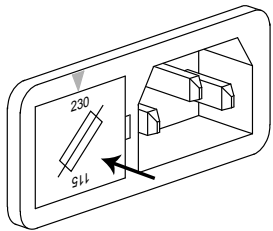

Fuse rating AC 115V: T0.63A/250V, AC 230V: T0.315A/250V

Specifications

The specifications apply when the GOS-630FC is powered on for at least 30 minutes under +20°C – +30°C.

Vertical	Sensitivity	1 mV/DIV to 2mV/DIV: ±5%
	accuracy	5mV/DIV to 5V/DIV: ±3%
	Bandwidth	1 mV/DIV to 2mV/DIV: DC to 7MHz
		5mV/DIV to 5V/DIV: DC to 30MHz
	AC coupling	> 10Hz (reference: 100kHz, 8DIV, -3dB)
	Rise time	1 mV/DIV to 2mV/DIV: Approx. 50nS
		5mV/DIV to 5V/DIV: Approx. 11.7nS
	Input impedance	Approx. 1M ohm // 25pF.
	Square wave characteristics	≤ 5% Overshoot at 10mV/DIV
	Linearity	Other ranges: 5% added to the above ±0.1DIV when moving 2 DIV at center
	Vertical mode	CH1, CH2, DUAL, ADD
	Chop frequency	Approx. 250kHz
	Input coupling	AC, GND, DC
	Max input voltage	CAT II 300Vpeak (AC: ≤ 1kHz)
	Max effective readout	Probe1:1 40Vpp (14Vrms Sine wave)
		Probe10:1 400Vpp (140Vrms Sine wave)
	Common mode rejection ratio	≥ 50:1 at 50kHz sine wave (CH1 and CH2 vertical scales are equal)
	Channel isolation @ 5mV/DIV	> 1000:1 at 50kHz
		> 30:1 at 30MHz
	CH1 signal output	≥ 20 mV/DIV @ 50Ω, 50Hz to 5MHz
CH2 INV BAL.	≤1 DIV (Reference at center graticule)	
Trigger	Trigger source	CH1, CH2, LINE, EXT
	Coupling	AC: 20Hz to full bandwidth
	Slope	+ / -
	Sensitivity	20Hz to 2MHz : 0.5 DIV (TRIG-ALT:2 DIV, EXT: 200mV)
		2MHz to 30MHz: 1.5 DIV (TRIG-ALT:3 DIV, EXT: 800mV)
		TV: Sync pulse > 1 DIV (EXT: 1V)
		Triggering modes
	EXT TRIG input	Input impedance: Approx.:1MΩ // 25pF Max. input: CAT II 300Vpeak < 1kHz

Horizontal Axis	Sweep time	0.2μS to 0.5S/DIV, ±3% accuracy
	x10MAG accuracy	±5% (20/50nS uncalibrated)
	Linearity	±3%, x10:±5% (20/50nS uncalibrated)
X-Y Mode	Sensitivity	Same as vertical axis
	Bandwidth	DC to at least 500kHz
	Phase Difference	≤3 degrees at DC to 50kHz
Z-Axis	Sensitivity	5Vpp (Positive going reduces intensity)
	Bandwidth	DC to 2MHz
	Input resistance	Approx. 47kΩ
	Max input voltage	CAT II 30Vpeak (AC ≤1kHz)
Probe Compensation Signal	Waveform	Positive-going square wave
	Frequency	Approx. 1 kHz
	Duty Ratio	Within 48:52
	Output voltage	2 Vp-p ±2%.
	Output impedance	Approx. 1 kΩ
Frequency Counter	Display Digits	Maximum 5 digit decimal
	Frequency Range	50Hz to 30MHz
	Accuracy	50Hz to 1kHz: ±0.05% 1kHz to 30MHz: ±0.02%
	Sensitivity	> 2DIV
LCD	Display	VOLT/DIV, TIME/DIV, X-Y, Frequency
	Backlight	Orange
CRT	Type	6-inch rectangular, internal graticule
	Phosphor	P 31
	Acceleration Volt.	Approx. 2kV
	Screen Size	8 × 10 DIV (1 DIV = 10mm (0.39in))
Power Source	AC115V/230V±15%, 50/60Hz	
Power	Approx. 40VA, 35W(max.)	
Operation Environment	Indoor use, Altitude ≤ 2000 m	
Environment	Ambient temperature :	
	To satisfy specifications:10°C to 35°C (50°F to 95°F)	
	Maximum operating range: 0°C to 40°C (32°F to 104°F)	
	Relative humidity: 85% RH(max.) non-condensing	
	Installation Category II, Pollution degree 2	
Storage Environment	Ambient temperature: -10°C to 70°C	
	Relative humidity: 70%RH (maximum)	
Accessories	Power cord x 1, User manual x 1, Probe x 2	
Dimensions	310 (W) x 150 (H) x 455 (D) mm	
Weight	Approx.8.2kgs (18.0lbs)	

Declaration of Conformity

We

GOOD WILL INSTRUMENT CO., LTD.

(1) No.7-1, Jhongsing Rd., Tucheng City, Taipei County, Taiwan

(2) No. 69, Lu San Road, Suzhou City (Xin Qu), Jiangsu Sheng, China

declare, that the below mentioned product

Type of Product: Oscilloscope

Model Number: GOS-630FC

are herewith confirmed to comply with the requirements set out in the Council Directive on the Approximation of the Law of Member States relating to Electromagnetic Compatibility (2004/108/EC, 92/31/EEC, 93/68/EEC) and Low Voltage Directive (2006/95/EC).

For the evaluation regarding the Electromagnetic Compatibility and Low Voltage Directive, the following standards were applied:

© **EMC**

EN 61326-1: Electrical equipment for measurement, control and laboratory use -- EMC requirements (2006)	
Conducted Emission	Electrical Fast Transients
Radiated Emission	EN 61000-4-4: 2004
EN 55011: 1998 + A1:1999 + A2:2002, ClassB	
Current Harmonics	Surge Immunity
EN 61000-3-2: 2000 + A2:2005	EN 61000-4-5: 1995 + A1:2001
Voltage Fluctuations	Conducted Susceptibility
EN 61000-3-3: 1995 + A1: 2001 +A2: 2005	EN 61000-4-6: 1996 + A1:2001
Electrostatic Discharge	Power Frequency Magnetic Field
EN 61000-4-2: 1995 + A1:1998 + A2:2001	EN 61000-4-8: 1993 + A1:2001
Radiated Immunity	Voltage Dip/ Interruption
EN 61000-4-3: 2002 + A1:2002	EN 61000-4-11: 2004

© **Safety**

Low Voltage Equipment Directive 2006/95/EC
Safety Requirements
IEC/EN 61010-1: 2001



Artisan Technology Group is your source for quality new and certified-used/pre-owned equipment

- FAST SHIPPING AND DELIVERY
- TENS OF THOUSANDS OF IN-STOCK ITEMS
- EQUIPMENT DEMOS
- HUNDREDS OF MANUFACTURERS SUPPORTED
- LEASING/MONTHLY RENTALS
- ITAR CERTIFIED SECURE ASSET SOLUTIONS

SERVICE CENTER REPAIRS

Experienced engineers and technicians on staff at our full-service, in-house repair center

*InstraView*SM REMOTE INSPECTION

Remotely inspect equipment before purchasing with our interactive website at www.instraview.com ↗

WE BUY USED EQUIPMENT

Sell your excess, underutilized, and idle used equipment. We also offer credit for buy-backs and trade-ins. www.artisanng.com/WeBuyEquipment ↗

LOOKING FOR MORE INFORMATION?

Visit us on the web at www.artisanng.com ↗ for more information on price quotations, drivers, technical specifications, manuals, and documentation

Contact us: (888) 88-SOURCE | sales@artisanng.com | www.artisanng.com