

*Model: ACC28*  
*MAG COIL FLOW RATE CONDITIONER*  
*FREQUENCY TO ANALOG VOLTAGE*  
*USER'S MANUAL*

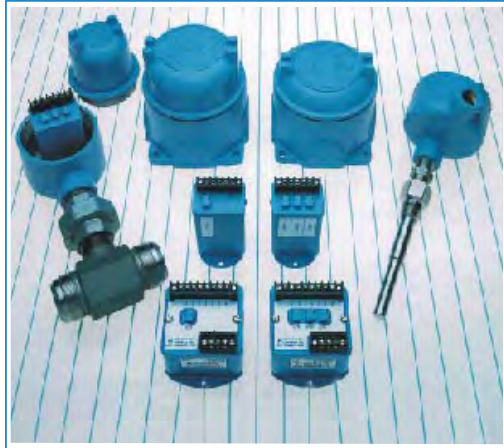

HP-247  
January 2011

**H** **HOFFER FLOW CONTROLS, INC.**  
**PERFECTING MEASUREMENT**

---

107 Kitty Hawk Lane, P.O. Box 2145, Elizabeth City, NC 27906-2145  
800-628-4584 252-331-1997 FAX 252-331-2886  
www.hofferflow.com E-mail: info@hofferflow.com



---

## Notice

HOFFER FLOW CONTROLS, INC. MAKES NO WARRANTY OF ANY KIND WITH REGARD TO THIS MATERIAL, INCLUDING, BUT NOT LIMITED TO, THE IMPLIED WARRANTIES OF MERCHANTABILITY AND FITNESS FOR A PARTICULAR PURPOSE.

This manual has been provided as an aid in installing, connecting, calibrating, operating, and servicing this unit. Every precaution for accuracy has been taken in the preparation of this manual; however, HOFFER FLOW CONTROLS, INC. neither assumes responsibility for any omissions or errors that may appear nor assumes liability for any damages that may result from the use of products in accordance with information contained in the manual.

HOFFER FLOW CONTROLS' policy is to provide a user manual for each item supplied. Therefore, all applicable user manuals should be examined before attempting to install or otherwise connect a number of related subsystems.

During installation, care must be taken to select the correct interconnecting wiring drawing. The choice of an incorrect connection drawing may result in damage to the system and/or one of the components.

Please review the complete model of each item to be connected and locate the appropriate manual(s) and/or drawing(s). Identify all model numbers exactly before making any connections. A number of options and accessories may be added to the main instrument, which are not shown on the basic user wiring. Consult the appropriate option or accessory user manual before connecting it to the system. In many cases, a system wiring drawing is available and may be requested from HOFFER FLOW CONTROLS.

This document contains proprietary information, which is protected by copyright. All rights are reserved. No part of this document may be photocopied, reproduced, or translated to another language without the prior consent of HOFFER FLOW CONTROLS, INC.

HOFFER FLOW CONTROLS' policy is to make running changes, not model changes, whenever an improvement is possible. This affords our customers the latest in technology and engineering. The information contained in this document is subject to change without notice.

---

## RETURN REQUESTS/INQUIRIES

---

Direct all warranty and repair requests/inquiries to the Hoffer Flow Controls Customer Service Department, telephone number (252) 331-1997 or 1-800-628-4584. BEFORE RETURNING ANY PRODUCT(S) TO HOFFER FLOW CONTROLS, PURCHASER MUST OBTAIN A RETURNED MATERIAL AUTHORIZATION (RMA) NUMBER FROM HOFFER FLOW CONTROLS' CUSTOMER SERVICE DEPARTMENT (IN ORDER TO AVOID PROCESSING DELAYS). The assigned RMA number should then be marked on the outside of the return package and on any correspondence.

FOR **WARRANTY** RETURNS, please have the following information available BEFORE contacting HOFFER FLOW CONTROLS:

1. P.O. number under which the product was PURCHASED,
2. Model and serial number of the product under warranty, and
3. Repair instructions and/or specific problems relative to the product.

FOR **NON-WARRANTY** REPAIRS OR **CALIBRATIONS**, consult HOFFER FLOW CONTROLS for current repair/calibration charges. Have the following information available BEFORE contacting HOFFER FLOW CONTROLS:

1. P.O. number to cover the COST of the repair/calibration,
2. Model and serial number of the product, and
3. Repair instructions and/or specific problems relative to the product.

---

---

## LIMITED WARRANTY

---

---

HOFFER FLOW CONTROLS, INC. ("HFC") warrants HFC's products ("goods") described in the specifications incorporated in this manual to be free from defects in material and workmanship under normal use and service, but only if such goods have been properly selected for the service intended, properly installed and properly operated and maintained. This warranty shall extend for a period of (1) year from the date of delivery to the original purchaser (or eighteen (18) months if the delivery to the original purchaser occurred outside the continental United States). This warranty is extended only to the original purchaser ("Purchaser"). *Purchaser's sole and exclusive remedy is the repair and/or replacement of nonconforming goods as provided in the following paragraphs.*

In the event Purchaser believes the goods are defective, the goods must be returned to HFC, transportation prepaid by Purchaser, within twelve (12) months after delivery of goods (or eighteen (18) months for goods delivered outside the continental United States) for inspection by HFC. If HFC's inspection determines that the workmanship or materials are defective, the goods will be either repaired or replaced, at HFC's sole determination, free of additional charge, and the goods will be returned, transportation paid by HFC, using the lowest cost transportation available.

Prior to returning the goods to HFC, Purchaser must obtain a Returned Material Authorization (RMA) Number from HFC's Customer Service Department within 30 days after discovery of a purported breach of warranty, but no later than the warranty period; otherwise, such claims shall be deemed waived. See the Return Requests/Inquiries Section of this manual.

If HFC's inspection reveals the goods are free of defects in material and workmanship or such inspection reveals the goods were improperly used, improperly installed, and/or improperly selected for service intended, HFC will notify the purchaser in writing and will deliver the goods back to purchaser upon (i) receipt of Purchaser's written instructions and (ii) the cost of transportation. If Purchaser does not respond within 30 days after notice from HFC, the goods will be disposed of in HFC's discretion.

HFC does not warrant these goods to meet the requirements of any safety code of any state, municipality, or any other jurisdiction, and purchaser assumes all risk and liability whatsoever resulting from the use thereof, whether used singly or in combination with other machines or apparatus.

This warranty shall not apply to any HFC goods or parts thereof, which have been repaired outside HFC's factory or altered in any way, or have been subject to misuse, negligence, or accident, or have not been operated in accordance with HFC's printed instructions or have been operated under conditions more severe than, or otherwise exceeding, those set forth in the specifications for such goods.

**THIS WARRANTY IS EXPRESSLY IN LIEU OF ALL OTHER WARRANTIES, EXPRESSED OR IMPLIED, INCLUDING ANY IMPLIED WARRANTY OF MERCHANTABILITY OR FITNESS FOR A PARTICULAR PURPOSE. HFC SHALL NOT BE LIABLE FOR ANY LOSS OR DAMAGE RESULTING, DIRECTLY OR INDIRECTLY, FROM THE USE OF LOSS OF USE OF THE GOODS. WITHOUT LIMITING THE GENERALITY OF THE FOREGOING, THIS EXCLUSION FROM LIABILITY EMBRACES THE PURCHASER'S EXPENSES FOR DOWNTIME, DAMAGES FOR WHICH THE PURCHASER MAY BE LIABLE TO OTHER PERSONS, DAMAGES TO PROPERTY, AND INJURY TO OR DEATH OF ANY PERSON. HFC NEITHER ASSUMES NOR AUTHORIZES ANY PERSON TO ASSUME FOR IT ANY OTHER LIABILITY IN CONNECTION WITH THE SALE OR USE OF HFC'S GOODS, AND THERE ARE NO AGREEMENTS OR WARRANTIES COLLATERAL TO OR AFFECTING THE AGREEMENT. PURCHASER'S SOLE AND EXCLUSIVE REMEDY IS THE REPAIR AND/OR REPLACEMENT OF NONCONFORMING GOODS AS PROVIDED IN THE PRECEDING PARAGRAPHS. HFC SHALL NOT BE LIABLE FOR ANY OTHER DAMAGES WHATSOEVER INCLUDING INDIRECT, INCIDENTAL, OR CONSEQUENTIAL DAMAGES.**

---

---

### **Disclaimer:**

Specifications are subject to change without notice.  
Some pages are left intentionally blank.

---

---

# TABLE OF CONTENTS

PREFACE .....	i
1 INTRODUCTION .....	1
1.1 INTRODUCTION .....	1
1.2 PERFORMANCE CHARACTERISTICS .....	1
1.3 ORDERING INFORMATION .....	2
1.4 WARRANTY .....	3
1.5 ENCLOSURE DETAIL .....	3
1.6 SHIPPING AND HANDLING .....	5
2 INSTALLATION .....	7
2.1 INSTALLATION WIRING LAYOUT FOR INTERCONNECTIONS .....	7
2.2 INSTALLATION OF THE ACC28 .....	7
3 FUNCTIONAL DESCRIPTION .....	9
3.1 INTRODUCTION .....	9
3.2 PRINCIPLE OF OPERATION .....	9
4 CALIBRATION PROCEDURE .....	11
4.1 INTRODUCTION .....	11
4.2 REQUIRED TEST EQUIPMENT .....	11
4.3 CONTROLS AND ADJUSTMENTS .....	12
4.4 PROCEDURE .....	13
5 MAINTENANCE .....	15
5.1 INTRODUCTION .....	15
5.2 TROUBLE SHOOTING AND MAINTENANCE .....	15
5.3 REPLACEMENT PARTS .....	18

THIS PAGE LEFT INTENTIONALLY

# PREFACE

---

This manual provides all the necessary information to correctly install, operate, maintain and troubleshoot the Model ACC28 frequency to voltage converter.

The ACC28 is intended to provide the user with a suitable interface between a frequency generating device and a data acquisition system.

This manual is organized to provide ease of use. Individual sections are provided to cover the Introduction, Installation, Functional Description, Calibration, and Maintenance and Troubleshooting. Illustrations have been used to improve the clarity of information provided in this manual.

THIS PAGE LEFT INTENTIONALLY



# 1 INTRODUCTION

---

## 1.1 INTRODUCTION

---

The Model ACC28 is a frequency to voltage converter that allows convenient interfacing to the turbine flowmeter which provides an analog voltage output proportional to flow rate.

The input signal conditioning circuitry is designed to accept the low level turbine flowmeter signal while providing rejection of unwanted noise and spurious signals. The output signal is a DC voltage which is proportional to flow rate.

## 1.2 PERFORMANCE CHARACTERISTICS

---

### INPUT:

- Input protected, RF and band pass filtered adjustable trigger level.
- Input Impedance 40 kilo ohm (nominal).
- Trigger Sensitivity 10 millivolt RMS (minimum) 10 Hz to 1000 Hz.
- Over voltage 120 volts RMS absolute (max.).

### VOLTAGE OUTPUT:

- Accuracy +/- .05% of full scale
- Temperature drift +/- 200 PPM/°C.
- Available range 0-1 VDC and 0-5 VDC.
- Response time 0.5 seconds for 10 to 90%, (adjustable).
- Output ripple less than 0.2% of F.S.
- Load resistance output can source up to 3 mA into a grounded load only.

### INPUT POWER:

- 10-35 VDC unregulated, 10 mA maximum.

### ENVIRONMENTAL:

- Operating 0-70 °C  
Storage -20-70 °C

### ENCLOSURES:

- General purpose (standard) Case, NEMA- 4, Explosion Proof

## 1.3 ORDERING INFORMATION

---

MODEL ACC28-(A)-(B)-(C)

ANALOG OUTPUT

INPUT POWER

ENCLOSURE STYLE

### ANALOG OUTPUT

MODEL ACC28-(A)-( )-( )

#### OPTION ( A )

- (1) 0-1 VDC
- (2) 0-5 VDC

### INPUT POWER

MODEL ACC28-( )-(B)-( )

#### OPTION ( B )

- (1) 10-35 VDC

### ENCLOSURE STYLE

MODEL ACC28-( )-( )-(C)

#### OPTION ( C )

- (1) STYLE 1 CASE, GENERAL PURPOSE
- (3H/O) MEETS CLASS 1, DIV. 1 AND 2, GROUP D ONLY  
CLASS II, GROUPS E, F, G  
CLASS III, NEMA 4X WITH 'O' RING  
CERTIFIED CSA, UL  
BODY KILARK #GECCT-3, STOCK #200-0945  
FLAT COVER, STOCK #200-0533, KILARK #GECBC
- (3BH/O) MEETS CLASS I, DIV. 1 AND 2, GROUPS A, B, C, D  
CLASS 1, ZONES 1 AND 2, GROUPS IIB + H2, IIA  
CLASS II, DIV. 1 AND 2, GROUPS E, F, G  
CLASS III NEMA 3, 4, 7 (B, C, D), 9 (E, F, G)  
CERTIFIED CENELEC, CSA, UL, FM  
BODY KILARK #HKB, STOCK #200-0406  
DOME COVER, STOCK #200-0405, KILARK #HK2D.

**INSERT (X) IN MODEL NUMBER FOR EVERY OPTION NOT SPECIFIED.**

## 1.4 WARRANTY

Hoffer Flow Controls warrants that all equipment will be free from defects in workmanship and material provided that such equipment was properly selected for the service intended, properly installed, and not misused. Equipment which is returned transportation prepaid to Hoffer Flow Controls within 12 months after delivery of goods, or 18 months from date of shipment on equipment for destination outside the United States, and is found by Hoffer Flow Controls inspection to be defective in workmanship or material, will be repaired or replaced at Hoffer Flow Controls sole option, free of charge and returned shipped using the lowest cost transportation prepaid.

In the event of product failure contact Hoffer Flow Controls at 252-331-1997 or 800-628-4584, for issuance of a **Returned Material Authorization (RMA)** number.

## 1.5 ENCLOSURE DETAIL

The ACC28 is may be packaged in either the General Purpose case (Style 1), in an Explosion Proof case (Style 3), or in the NEMA 4 case (style 5). Dimensions are given in Figures 1-2, 1-3, and 1-4.

**Figure 1-2 General Purpose Case (Style 1)**

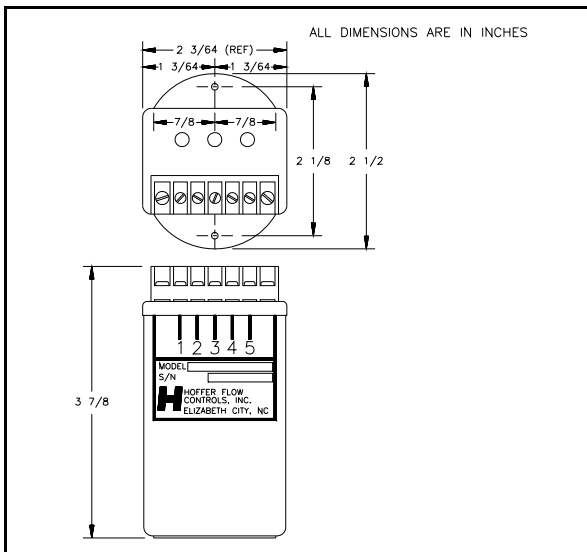

**Figure 1-3 Explosion Proof Case (Style 3)**

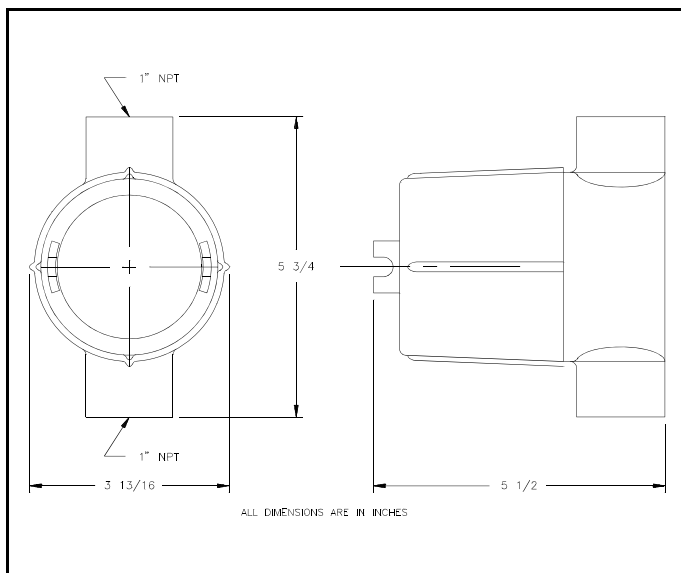

**Figure 1-4 NEMA 4 Case (Style 5)**

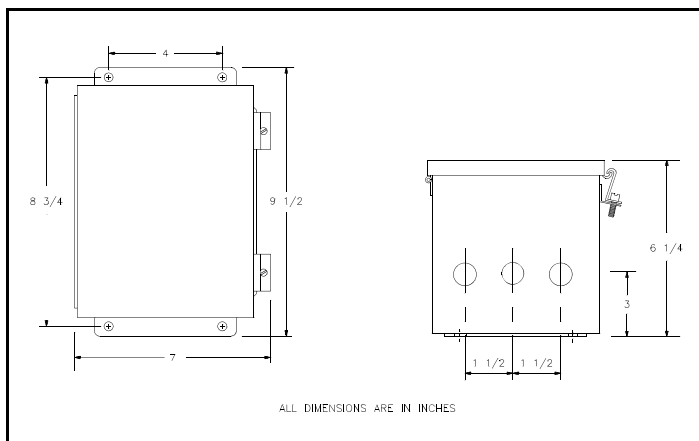

## **1.6 SHIPPING AND HANDLING**

---

**CAUTION: The ACC28B is a static-sensitive device and standard practice for static sensitive parts should be observed.**

---

In the event of malfunctioning equipment the following guidelines should be observed for the preparation and shipment of the equipment. Failure to do so may result in the material reaching its destination damaged.

The electronic unit due to its **STATIC SENSITIVE** nature should be wrapped in a material conforming to MIL-B-81705, Type II, and packaged in a heat sealable bag conforming to MIL-P-81997. These steps are necessary to protect the equipment from electrostatic charge(s) that may occur during handling.

The package should then be marked with a sensitive electronic device caution label conforming to MIL-STD-129, appendix C. The equipment should then be wrapped in cushioning material, and placed into a close fitting box conforming to PPP-B-636 Domestic class.

The exterior shipping container should be marked with a sensitive electronic device caution label conforming to MIL-STD-129, appendix C.

Clearly mark the factory provided RMA number on all paperwork and shipping packaging.

THIS PAGE LEFT INTENTIONALLY

## **2           INSTALLATION**

---

### **2.1       INSTALLATION WIRING LAYOUT FOR INTERCONNECTIONS**

---

In considering the interconnections between the flowmeter and the flow measurement system some attention must be given to anticipated noise sources and to the coupling of these noise sources to the interconnecting wiring.

Noise signals may be coupled inductively or capacitively into the wiring between the sensor and the electronic measuring systems. In general, utilizing a shielded, twisted pair for the interconnection greatly reduces this coupling. The shield should be grounded on one end of the cable only. In general, grounding only on the electronic measuring system is best.

However, even with proper interconnecting cabling cross talk with other signal lines or power lines may still occur and should be avoided. Physical isolation of the wiring reduces the chance of potential problems.

### **2.2       INSTALLATION OF THE ACC28**

---

The model ACC28 should be placed in a convenient location which maintains access to the unit should repairs or readjustment be required.

Refer to wiring installation Figure 2-1 for appropriate terminals for interconnections. Connections to the terminal block should be carefully dressed to avoid having bare wires extending past the screw clamp on the terminal block. This is particularly important for units mounted within the explosion proof enclosure. Wires should be neatly dressed near the bottom of the enclosure to prevent problems when the cover is installed.

Connect two conductor shielded cable from the flowmeter. Connect shield to ACC28 only.

Unit is powered by a DC voltage which must be within 8 to 40 volts. Connect power as outlined in installation drawing.

## Figure 2-1 Installation wiring

NOTES:

1. INPUT POWER 10 VDC (MIN.) TO 35 VDC (MAX.).
2. RECOMMENDED CABLE: SHIELDED, TWISTED PAIR #24 GAUGE.
3. TERMINAL BLOCK DIRECTLY ACCEPTS WIRE LEADS.

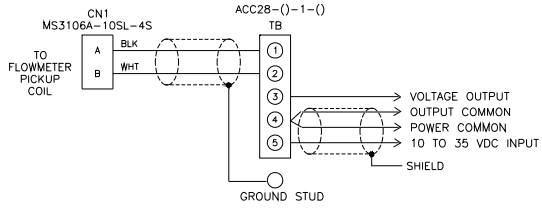



## 3 FUNCTIONAL DESCRIPTION

---

### 3.1 INTRODUCTION

---

The ACC28 is a frequency to voltage transmitter which will provide an analog output voltage proportional to rate of flow. The unit is intended to provide the user with a suitable interface between a flow measurement sensor and a data acquisition system.

### 3.2 PRINCIPLE OF OPERATION

---

A block diagram showing functional blocks of the unit is depicted in Figure 3.1. The principle of operation is as follows.

The electronics unit receives the signal from the flowmeter pickup coil and converts it to a current output proportional to flow rate.

The electronics unit requires power of 8 to 40 VDC.

The frequency signal which is generated from the flowmeter is connected to the ACC28 with a twisted shielded pair cable. The signal enters the SENSITIVITY control which is used to reject unwanted noise by raising the trigger threshold above the background noise present.

The low level flowmeter signal is then passed through a signal conditioning chain where it is filtered, amplified and shaped into a train of digital pulses whose frequency is related to the volume flow rate and where each pulse represents a discrete volume of fluid.

The signal entering the frequency to voltage converter is passed through a combination of a divide by N and a DIP switch matrix. The divide by N output is chosen whose pulse rate is between 75 and 150 Hz at the maximum flow rate measured. This scaled pulse rate is then filtered into an analog voltage. This voltage is proportional to volumetric flow rate.

The resulting output voltage related to flow is then fed into the output amplifier. The output amplifier is a voltage to voltage amplifier and offers ZERO and SPAN adjustments and is available in standard process ranges of 0-1 VDC or 0-5 VDC.

**Figure 3.1 Block Diagram**

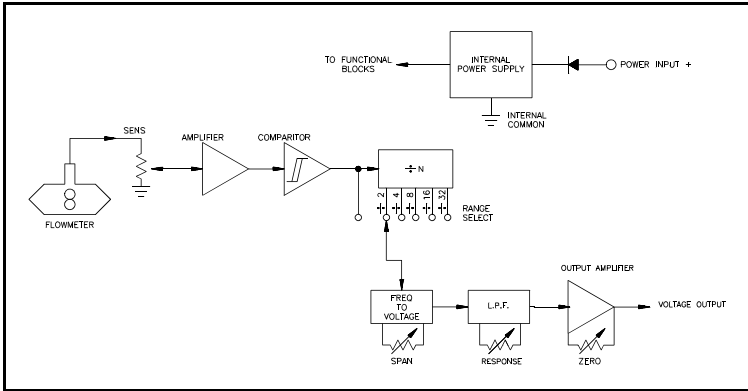

## 4 CALIBRATION PROCEDURE

---

### 4.1 INTRODUCTION

---

In general, all flow measurement systems supplied by Hoffer Flow Controls have been factory calibrated as specified by the user, at the time of purchase, free of charge.

All systems which underwent such a factory calibration have a calibration setup sheet included with the shipment. This sheet contains the details of analog outputs, as well as, other useful calibration data.

Field calibration is only required when a change has occurred or is sought to the measuring system. Such a change may be due to repair, replacement or recalibration of the flowmeter or perhaps a change in the analog output span.

### 4.2 REQUIRED TEST EQUIPMENT

---

In order to calibrate and troubleshoot the ACC28 the following suggested equipment list is provided:

MANUFACTURER	PART NUMBER	DESCRIPTION
Fluke	8060A	True RMS Multimeter
Simpson	420	Function Generator
Viz	WD-755	Multi Function Counter
Spectrol	8-T000	Adjustment Tool

## 4.3 CONTROLS AND ADJUSTMENTS

**SENSITIVITY:** A twenty turn control used to set the threshold sensitivity level above the ambient noise pickup.

**RANGE:** A dual in line (DIP) switch located within the enclosure which is used to program the module to accept an input frequency range.

**SPAN:** A multiple turn adjustment which is used to set the current output signal to the desired span corresponding to the equivalent flow range. (i.e., 0 to 5 VDC corresponding to 0-100 GPM).

**ZERO:** A multiple turn adjustment which is used to set output signal with no flow to the desired "zero" value. (i.e., 0 VDC).

---

**NOTE: IT IS NECESSARY TO OPEN THE COVER OF THE ENCLOSURE BY REMOVING TWO SCREWS ON SIDE OF BOX AND LIFTING COVER. TWO PRINTED CIRCUIT CARDS ARE ATTACHED. THE "RANGE" DIP SWITCH MAY BE PROGRAMMED WITH A PEN.**

---

**Figure 4-1 Control and Adjustment Detail**

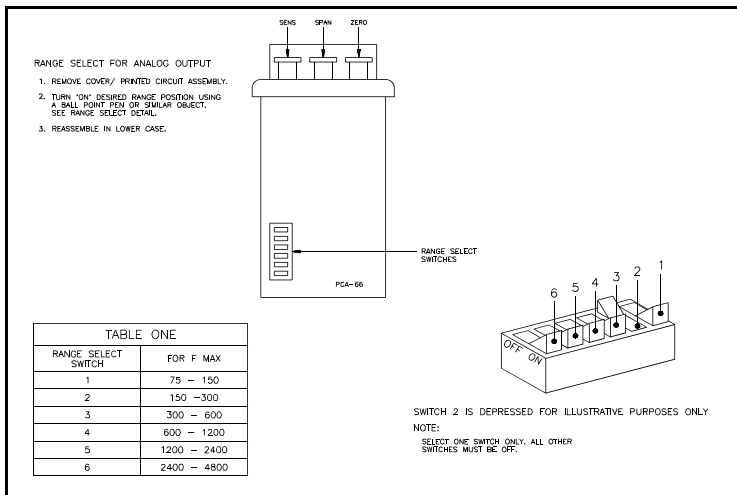

## 4.4 PROCEDURE

---

Begin by determining the equivalent maximum volumetric flow rate in GPM, expected by the application, term this GPM (MAX). GPM (MAX) may be calculated based on the analog output scale requirements or may be the maximum flow rate listed on the flowmeter's calibration sheet.

From the calibration constant (or K Factor) listed on the data sheet for the flowmeter, obtain the frequency corresponding to GPM (MAX) using Equation 1 and designate this frequency F (MAX).

### Equation 1

$$F_{MAX} = \frac{GPM_{MAX} \times K_{AVE}}{60}$$

Where:

FMAX is the maximum input frequency.

KAVE is the average calibration factor.

The analog output of the ACC28B may be calibrated with the aid of an external oscillator used in conjunction with a frequency counter.

The external oscillator is used to supply a test frequency. In this method, the external oscillator is connected to the signal input terminals as shown in Figure 4-2. The oscillator's output frequency is set to equal F (MAX) as indicated on the frequency counter.

- The course range adjustment is accomplished by selecting a switch position on a DIP switch located on the PCA-66 printed circuit card. See Table 4-1 to determine required switch position and set into switch as shown in Figure 4-1 for anticipated F MAX.

**Table 4-1 : Range Select**

INPUT FREQUENCY FMAX	SWITCH POSITION
75 TO 150 Hz	1
150 TO 300 Hz	2
300 TO 600 Hz	3
600 TO 1200 Hz	4
1200 TO 2400 Hz	5
2400 TO 4800 Hz	6

- Connect a digital voltmeter as shown in Figure 4-2.

**Figure 4-2 Test Setup**

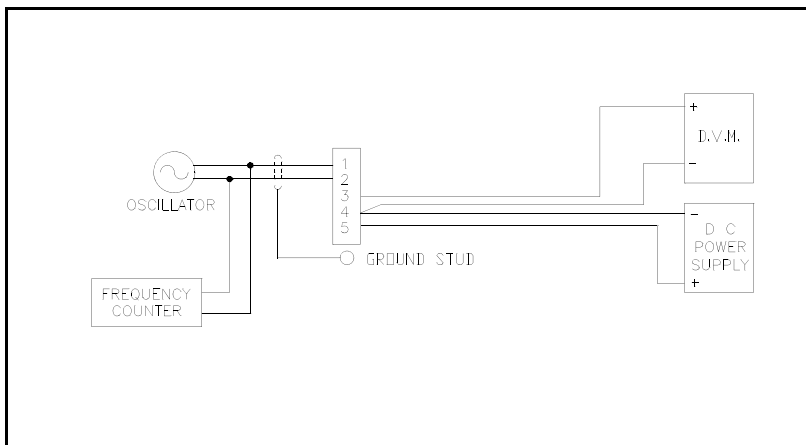

- Adjust ZERO control for desired zero voltage (i.e., 0 VDC). See test setup shown in Figure 4-2.
- Inject the test frequency equal to Fmax while adjusting SPAN for current equal to the desired Full Scale voltage output, (i.e., 1 VDC or 5 VDC).
- Adjust ZERO control for desired zero voltage (i.e., 0 VDC). See test setup shown in Figure 4-2.
- Iterate SPAN and ZERO adjustment for the desired current output until no change is observed.

## 5 MAINTENANCE

---

### 5.1 INTRODUCTION

---

Hoffer Flow Controls flow measurement systems are constructed to give a long service life in the targeted measuring field and service environment. However, problems do occur from time to time and the following points should be considered for preventative maintenance and repairs.

The bearing type used in the flowmeter was chosen to give compromise between long life, chemical resistance, ease of maintenance and performance. A preventative maintenance schedule should be established to determine the amount of wear which has occurred since last overhaul. See users manual for flowmeter for further instructions.

A spare parts list has been provided which, at the discretion of the user, may be user stocked. Consult with the manufacturer if an abridged spare parts list is sought. The recommended spare list may be found following this section and in the users manual for the flowmeter.

In case the flow measurement system malfunctions or becomes inoperative, a trouble shooting procedure follows.

Factory consultation is available to assist in diagnosing problems. In addition, factory repair parts and service are available for individuals who wish to utilize this service.

### 5.2 TROUBLE SHOOTING AND MAINTENANCE

---

- ALL PRINTED CIRCUIT CARDS ARE WARRANTED FOR ONE YEAR AFTER DATE OF SALE.
- ALL PRINTED CIRCUIT CARDS MAY BE FACTORY REPAIRED AT A NOMINAL FEE FOR PARTS AND LABOR AFTER WARRANTY PERIOD.

In case of an inoperable or malfunctioning system the following procedures can be used to isolate the faulty wiring, printed circuit boards and/or alternate causes. The majority of repairs can be made in the field thereby reducing the time a unit is out of service. The necessary documentation is contained within this manual with the exception of the calibration data sheet for the turbine flowmeter. This calibration is supplied separately.

Factory consultation is available to assist in diagnosing problems. Please note that in some cases factory repairs can be performed more easily than can be accomplished in the field.

Failure conditions are listed and the possible corrective actions given to eliminate the observed problem.



OBSERVED CONDITION	CORRECTIVE ACTION
<ul style="list-style-type: none"> <li>● ANALOG OUTPUT WITH NO FLOW</li> </ul>	<ul style="list-style-type: none"> <li>● NOISE ON INPUT. SLOWLY TURN SENS POT CCW UNTIL FALSE INDICATION STOPS.</li> <li>● NOTE: IN FULLY CCW POSITION THE UNIT WILL NOT OPERATE.</li> <li>● REPLACE PICKUP COIL.</li> <li>● DEFECTIVE ACC28.REPAIR OR REPLACE.</li> </ul>
<ul style="list-style-type: none"> <li>● INCORRECT ZERO READING WITH NO FLOW.</li> </ul>	<ul style="list-style-type: none"> <li>● VERIFY THAT POWER SUPPLY VOLTAGE IS WITHIN LIMIT.</li> <li>● UNIT IS OUT OF CALIBRATION. RECALIBRATE.</li> <li>● DEFECTIVE ACC28.REPAIR OR REPLACE.</li> </ul>
<ul style="list-style-type: none"> <li>● VOLTAGE EXCEEDS DESIRED SPAN.</li> </ul>	<ul style="list-style-type: none"> <li>● FLOWMETER BEING USED BEYOND CALIBRATED SPAN OF ACC28.</li> <li>● CALIBRATION OF ACC28 INCORRECT. RECALIBRATE.</li> <li>● DEFECTIVE UNIT. REPAIR OR REPLACE.</li> </ul>
<ul style="list-style-type: none"> <li>● INCORRECT ANALOG OUTPUT.</li> </ul>	<ul style="list-style-type: none"> <li>● LOAD RESISTANCE TOO SMALL.</li> <li>● NOISE PICKUP PRESENT. ADJUST SENSITIVITY.</li> <li>● CALIBRATION OF ACC28 INCORRECT. RECALIBRATE.</li> <li>● DEFECTIVE UNIT.REPAIR OR REPLACE.</li> </ul>
<ul style="list-style-type: none"> <li>● LARGE RIPPLE ON ANALOG OUTPUT.</li> </ul>	<ul style="list-style-type: none"> <li>● WRONG "RANGE" SWITCH SELECTED. RECALIBRATE.</li> <li>● FLOWMETER BEING OPERATED BELOW RANGE ADJUST RESPONSE CONTROL TO MINIMIZE RIPPLE.</li> </ul>

### 5.3 REPLACEMENT PARTS

<b>PART NUMBER</b>	<b>DESCRIPTION</b>
ACC28-1-1-1	0 TO 1 VDC OUTPUT ASSEMBLY
ACC28-5-1-1	0 TO 5 VDC OUTPUT ASSEMBLY