

MICROCYBER

HT1200M User Manual

HART Modem ASIC
(According to HCF_SPEC-54)

Version: 1.1
Date: 07.12

Copyright and Disclaimer

Copyright 2007 SIA. All rights reserved.

The information in this document is proprietary and confidential to SIA, and for its customers' internal use. In any event, no part of this document may be reproduced or redistributed in any form without the express written consent of SIA.

None of the information contained in this document constitutes an express or implied warranty by SIA as to the sufficiency, fitness or suitability for a particular purpose of any such information or the fitness, or suitability for a particular purpose, merchantability, performance, compatibility with other parts or systems, or any portion thereof, referred to in this document. SIA expressly disclaims all representations and warranties of any kind regarding the contents or use of the information, including, but not limited to, express and implied warranties of accuracy, completeness, merchantability, fitness for a particular use, or non-infringement. In no event will SIA be liable for any direct, indirect, special, incidental or consequential damages, including, but not limited to, lost profits, lost business or lost data resulting from any use of or reliance upon the information, whether or not SIA has been advised of the possibility of such damage.

Shenyang Institute of Automation (SIA)
No.114 Nanta Street, Dongling District,
Shenyang, P.R.China, 110016
www.sia.cn

Revision History

Version	Release Date	Detail of Changes
1.1	07.12.22	First release

List of Contents

General Description	5
Features	5
Typical Application	6
Pin Assignment	6
Pin Description.....	8
Function Description.....	10
Package Information	15
Characteristics	17

List of Tables

Table 1 HT1200M Pin Descriptions.....	7
---------------------------------------	---

List of Figures

Figure 1 HT1200M Hart Modem Typical Application.....	6
Figure 2 (a) 28Pin PLCC Pinout Package (b) 32Pin LQFP Pinout Package.....	6
Figure 3 Reset Timing.....	8
Figure 4 HT1200M Block Diagram	10
Figure 5 Demodulator Signal Timing.....	11
Figure 6 OTXA Waveform (1200 Hz).....	11
Figure 7 OTXA Waveform (2200 Hz).....	12
Figure 8 Receive Schematic.....	13
Figure 9 (a) Crystal Oscillator (b) Oscillator	14
Figure 10 LQFP32.....	15
Figure 11 PLCC28.....	16

General Description

The HT1200M is a single-chip, CMOS modem for use in Highway Addressable Remote Transducer (HART) field instruments and masters. The modem and a few external passive components provide all of the functions needed to satisfy HART physical layer requirements including modulation, demodulation, receive filtering, carrier detect and transmit-signal shaping. The HT1200M is pin-compatible with the SYM20C15. See the Pin Description and Functional Description sections for details on pin compatibility with the SYM20C15.

The HT1200M uses Phase Continuous Frequency Shift Keying (FSK) at 1200 bits per second. To conserve power the receive circuits are disabled during transmit operations and vice versa. This provides the half-duplex operation used in HART communications.

Features

- Can be used in designs presently using the SYM20C15 or equivalent type chip
- Single-chip, half-duplex 1200 bits per second FSK modem
- Bell 202 shift frequencies of 1200 Hz and 2200 Hz
- 3.3V-5.0V power supply
- Transmit-signal wave shaping
- Receive band-pass filter
- Low power: optimal for intrinsically safe applications CMOS compatible
- Internal oscillator requires 460.8kHz crystal or ceramic resonator
- Meets HART physical layer requirements
- Industrial temperature range of -40 °C to +85 °C
- Available in a 28-pin PLCC and 32-pin LQFP packages

Typical Application

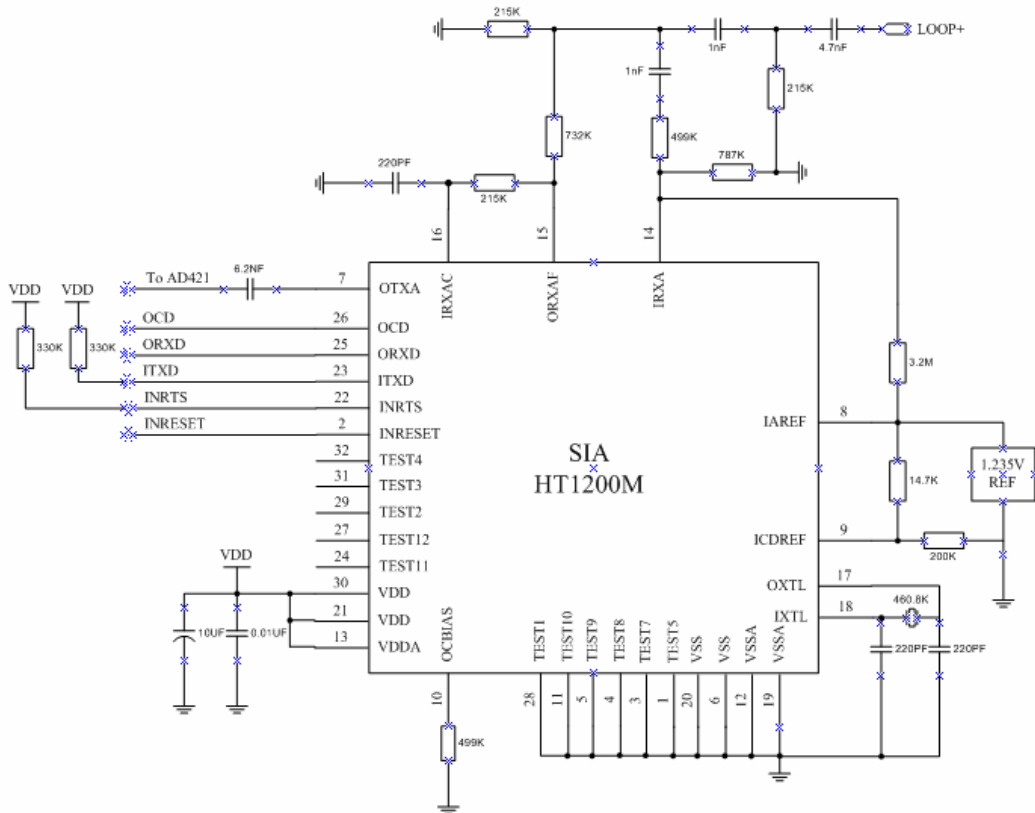

Figure 1 HT1200M Hart Modem Typical Application

Pin Assignment

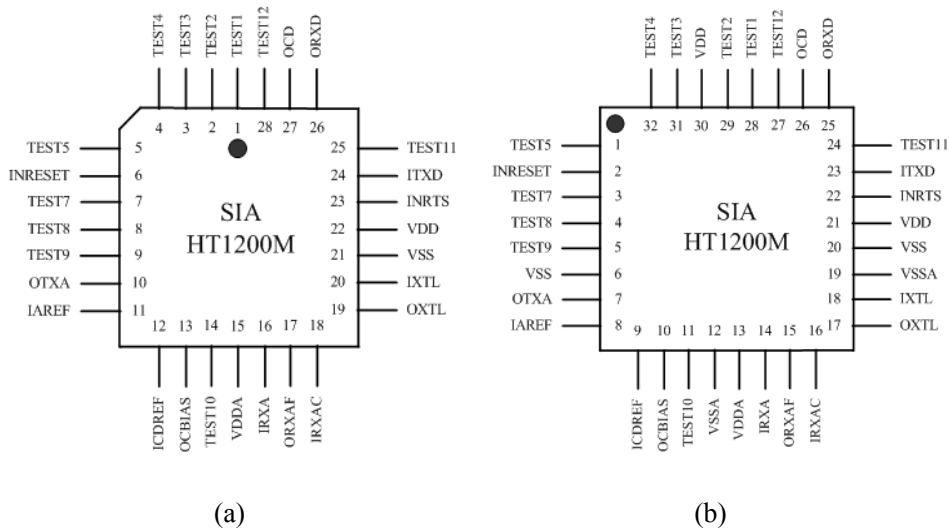

Figure 2 (a) 28Pin PLCC Pinout Package (b) 32Pin LQFP Pinout Package

Signal	Type	PLCC	LQFP	Description
TEST1	input	1	28	Connect to Vss.
TEST2	—	2	29	No connect.
TEST3	—	3	31	No connect.
TEST4	—	4	32	No connect.
TEST5	input	5	1	Connect to Vss.
INRESET	input	6	2	Reset all digital logic when low
TEST7	input	7	3	Connect to Vss.
TEST8	input	8	4	Connect to Vss.
TEST9	input	9	5	Connect to Vss.
OTXA	output	10	7	Modulated output transmit and transmit signal to 4-20mA loop. FSK modulated HART interface circuit.
IAREF	input	11	8	Analog reference voltage.
ICDREF	input	12	9	Carrier detect reference voltage.
OCBIAS	output	13	10	Comparator bias current.
TEST10	input	14	11	Connect to Vss.
VDDA	power	15	13	Analog supply voltage.
IRXA	input	16	14	FSK modulated HART receive signal from 4-20mA loop interface circuit
ORXAF	output	17	15	Analog receiver filter input.
IRXAC	input	18	16	Analog receive comparator input.
OXTL	output	19	17	Crystal oscillator output.
IXTL	input	20	18	Crystal oscillator input.
VSS	ground	21	6,20	Ground.
VDD	power	22	21,30	Digital supply voltage.
INRTS	input	23	22	Request to send.
ITXD	input	24	23	Input transmit data. Transmitted HART data stream from UART.
TEST11	—	25	24	No connect.
ORXD	output	26	25	Received demodulated HART data to UART.
OCD	output	27	26	Carrier detect output.
TEST12	—	28	27	No connect.
VSSA	ground	—	12,19	Analog ground

Pin Description

IAREF: Analog Reference Voltage

This analog input sets the do operating point of the operational amplifiers and comparators and is usually selected to split the do potential between VDD and Vss. IAREF in DC Characteristics refer to Electrical Characteristics.

ICDREF: Carrier Detect Reference Voltage

This analog input controls at which level the carrier detect (OCD) becomes active. This is determined by the do voltage difference between ICDREF and IAREF. Selecting ICDREF-IAREF equal to $0.08 V_{DC}$ will set the carrier detect to a nominal 100 mVp-p.

INRESET: Reset Digital Logic

When at logic low (VSS) this input holds all the digital logic in Reset. During normal operation INRESET should be at VDD. INRESET should be held low for a minimum of 10 ns after VDD=2.5 V as shown in Figure 3.

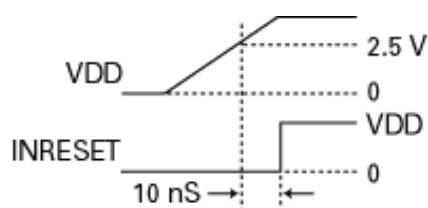

Figure 3 Reset Timing

INRTS: Request To Send

This active-low input selects the operation of the modulator. OTXA is enabled when this signal is low. This signal must be held high during power-up.

IRXA: Analog Receive Input

This input accepts the 1200/2200 Hz signals from the external filter.

IRXAC: Analog Receive Comparator Input

This is the positive input of the carrier detect comparator and the receiver filter comparator.

ITXD: Digital Transmit Input(CMOS)

This input to the modulator accepts digital data in NRZ form. When ITXD is low, the modulator output frequency is 2200 Hz. When ITXD is high, the modulator output frequency is 1200 Hz.

IXTL: Oscillator Input

This input to the internal oscillator must be connected to a parallel mode 460.8 kHz

ceramic resonator when using the internal oscillator or grounded when using an external 460.8 kHz clock signal.

OCBIAS: Comparator Bias Current

The current through this output controls the operating parameters of the internal operational amplifiers and comparators. For normal operation, OCBIAS current is set to 2.5 uA.

OCD: Carrier Detect Output

This output goes high when a valid input is recognized on IRXA. If the received signal is greater than the threshold specified on ICDREF for four cycles of the IRXA signal, the valid input is recognized.

ORXAF: Analog Receive Filter Output

This signal is the square wave output of the receiver high-pass filter.

ORCD: Digital Receive Output (CMOS)

This signal outputs the digital receive data. When the received signal (IRXA) is 1200 Hz, ORXD outputs logic high. When the received signal (IRXA) is 2200 Hz, ORXD outputs logic low. ORXD is qualified internally with OCD and is logic high when OCD is low.

OTXA: Analog Transmit Output

This output provides the trapezoidal signal controlled by ITXD. When ITXD is low, the output frequency is 2200 Hz. When ITXD is high, the output frequency is 1200 Hz. This output is active when INRTS is low and 0.5 VDD when INRTS is high.

OXTL: Oscillator Output

This output from the internal oscillator must be connected to an external 460.8 kHz clock signal or to a parallel mode 460.8 kHz ceramic resonator when using the internal oscillator.

TEST(12: 1): Test Pin

These are test pins. For normal operation, tie these signals as per Table1.

VDD: Digital Power

This is the power for the digital modem circuitry.

VDDA: Analog Supply Voltage

This is the power for the analog modem circuitry.

VSS: Ground

This is the analog and digital ground.

VSSA: Analog Ground

Analog Ground

Function Description

The HT1200M is a functional equivalent of the SYM20C15 HART Modem. It contains a transmit data modulator and signal shaper, carrier detect circuitry, analog receiver and demodulator circuitry and an oscillator, as shown in Figure 4.

The internal HART modulates the transmit-signal and demodulates the receive signal. The transmit-signal shaper enables the HT1200M to transmit a HART compliant signal. The carrier is detected by comparing the receiver filter output with the difference between two external voltage references. The analog receive circuitry band-pass filters the received signal for input to the modem and the carrier detect circuitry. The oscillator provides the modem with a stable time base using either a simple external resonator or an external clock source.

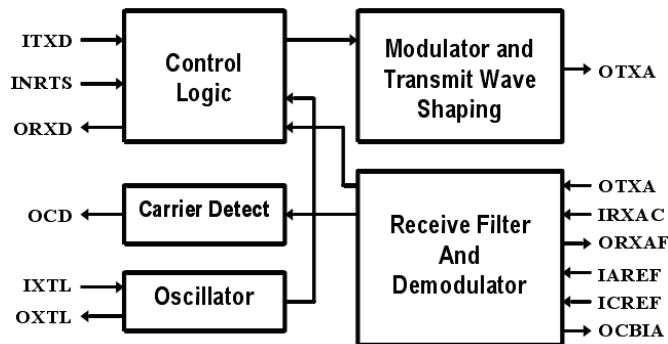

Figure 4 HT1200M Block Diagram

HT1200M LOGIC

The modem consists of a modulator and demodulator. The modem uses shift frequencies of nominally 1200 Hz (for a 1) and 2200 Hz (for a 0). The bit rate is 1200 bits/second.

Modulator

The modulator accepts digital data in NRZ form at the ITXD input and generates the FSK modulated signal at the OTXA output. INRTS must be a logic low for the modulator to be active.

Demodulator

The demodulator accepts an FSK signal at the IRXA input and reproduces the original modulating signal at the ORXD output. The nominal bit rate is 1200 bits per second. Figure 5 illustrates the demodulation process.

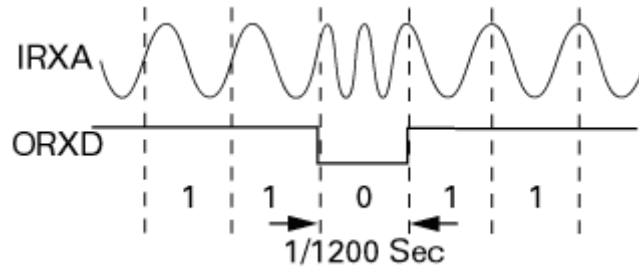

Figure 5 Demodulator Signal Timing

The output of the demodulator is qualified with the carrier detect signal (OCD), therefore, only IRXA signals large enough to be detected (100 mVp-p typically) by the carrier detect circuit produce received serial data at ORXD. Maximum demodulator jitter is 12 percent of one bit given input frequencies within HART specifications, a clock frequency of 460.8 kHz (1.0 percent) and zero input (IRXA) asymmetry.

TRANSMIT-SIGNAL SHAPER

The transmit-signal shaper generates a HART compliant FSK modulated signal at OTXA. Figure 6 and Figure 7 show the transmit-signal forms of the HT1200M.

For IAREF=1.235 V_{DC}, OTXA will have a voltage swing from approximately 0.25 to 0.75 V_{DC}.

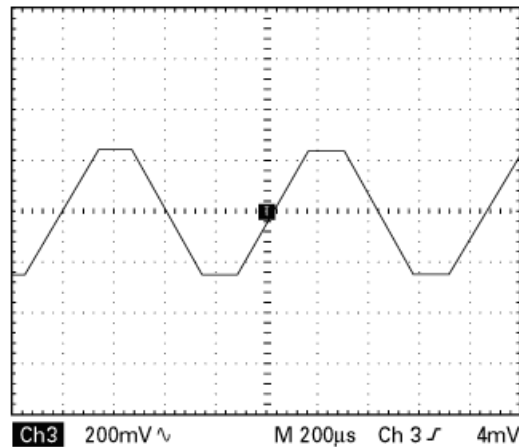

Figure 6 OTXA Waveform (1200 Hz)

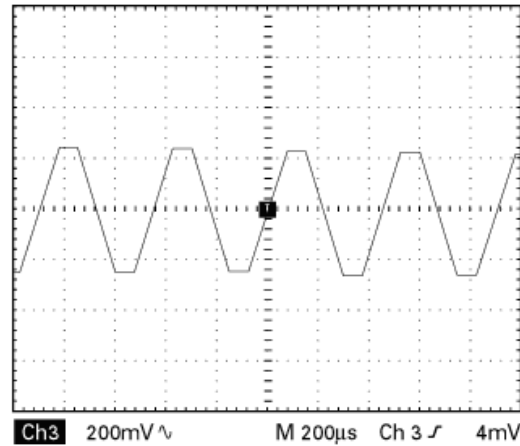

Figure 7 OTXA Waveform (2200 Hz)

CARRIER DETECT CIRCUITRY

The Carrier Detect Comparator shown in Figure 8 below generates logic low output if the IRXAC voltage is below ICDREF. The comparator output is fed into a carrier detect block. The carrier detect block drives the carrier detect output pin OCD high if INRTS is high and four consecutive pulses out of the comparator have arrived. OCD stays high as long as INRTS is high and the next comparator pulse is received in less than 2.5 ms. Once OCD goes inactive, it takes four consecutive pulses out of the comparator to assert OCD again. Four consecutive pulses amount to 3.33 ms when the received signal is 1200 Hz and to 1.82 ms when the received signal is 2200 Hz.

ANALOG RECEIVER CIRCUITRY

Voltage References

The HT1200M requires two voltage references: IAREF and ICDREF. IAREF sets the do operating point of the internal operational amplifiers and comparators. A 1.235 V_{DC} reference(Analog Devices AD589) is suitable as IAREF. The level at which OCD (carrier detect) becomes active is determined by the do voltage difference (ICDREF-IAREF). Selecting a voltage difference of 0.08 V_{DC} will set the carrier detect to a nominal 100 mVp-p.

Bias Current Resistor

The HT1200M requires a bias current resistor to be connected between OCBIAS and V_{ss}. The bias current controls the operating parameters of the internal operational amplifiers and comparators. The value of the bias current resistor is determined by the reference voltage IAREF and the following formula:

$$R_{BIAS} = \left(\frac{IAREF}{2.5\mu A} \right)$$

The recommended bias current resistor is 500 ohm; when IAREF is equal to 1.235 V_{DC}.

In Figure 8 all external capacitor values have a tolerance of 15 percent and the resistors have a tolerance of 1 percent, except the 3 ohm; which has a tolerance of 15 percent. External to the HT1200M, the filter exhibits a three-pole, high-pass filter at 624 Hz and a one-pole, low-pass filter at 2500 Hz.

Internally, the HT1200M has a high-pass pole at 35 Hz and a low-pass pole at 90 kHz. The low-pass pole can vary as much as 130 percent. The input impedance of the entire filter is greater than 150 ohm; at frequencies below 50 kHz.

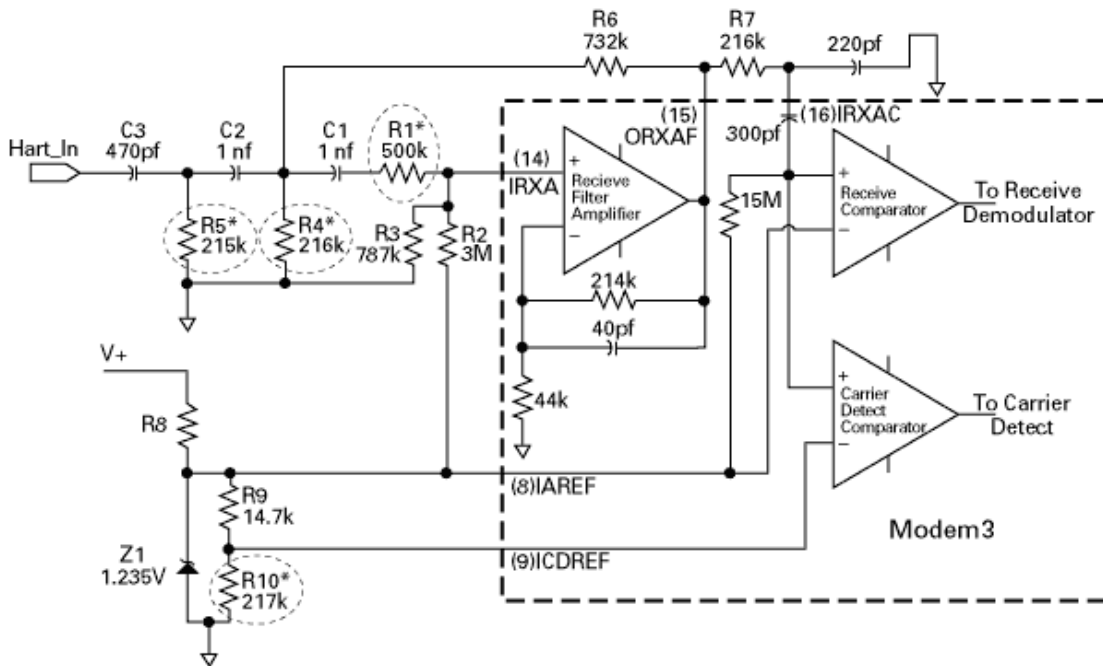

Figure 8 Receive Schematic

OSCILLATOR

The HT1200M requires a 460.8 kHz clock signal on OXTL. This can be provided by an external clock or external components may be connected to the HT1200M internal oscillator.

Internal Oscillator Option

The oscillator cell will function with either a 460.8 kHz crystal or ceramic resonator. A parallel resonant ceramic resonator can be connected between OXTL and IXTL. Figure 9 illustrates the crystal option for clock generation using a 460.8 kHz (1 percent tolerance) parallel resonant crystal and two tuning capacitors. The actual values of the capacitors may depend on the recommendations of the manufacturer of the resonator. Typically, capacitors in the range of 100 pF to 470pF are used.

External Clock Option

It may be desirable to use an external 460.8 kHz clock as shown in Figure 10 rather than the internal oscillator because of the high cost and low availability of ceramic resonators. In addition, the HT 1200M consumes less current when an external clock is used. Minimum current consumption occurs with the clock connected to OXTL and IXTL connected to VSS.

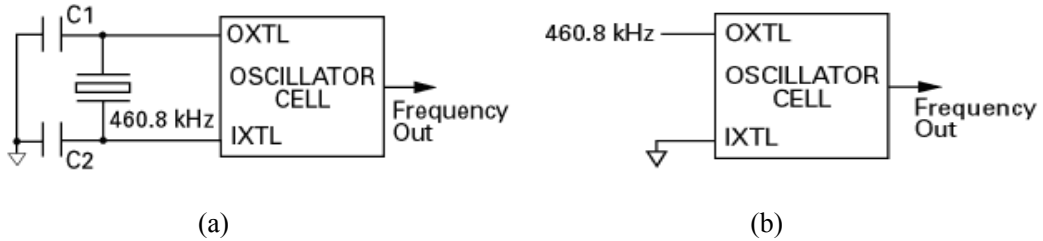
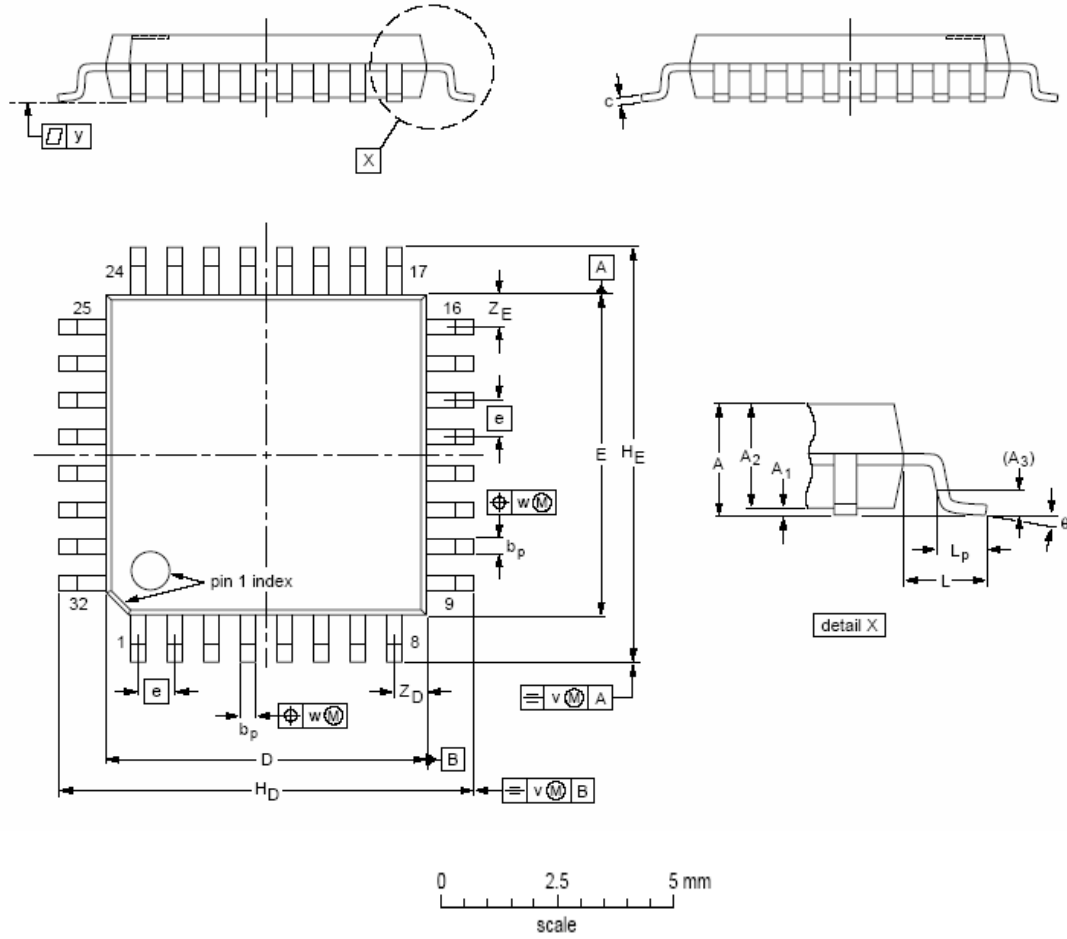

Figure 9 (a) Crystal Oscillator (b) Oscillator

Package Information



UNIT	A max.	A ₁	A ₂	A ₃	b _p	c	D ⁽¹⁾	E ⁽¹⁾	e	H _D	H _E	L	L _p	v	w	y	Z _D ⁽¹⁾	Z _E ⁽¹⁾	θ
mm	1.60	0.20 0.05	1.45 1.35	0.25	0.4 0.3	0.18 0.12	7.1 6.9	7.1 6.9	0.8	9.15 8.85	9.15 8.85	1.0	0.75 0.45	0.2	0.25	0.1	0.9 0.5	0.9 0.5	7° 0°

Figure 10 LQFP32

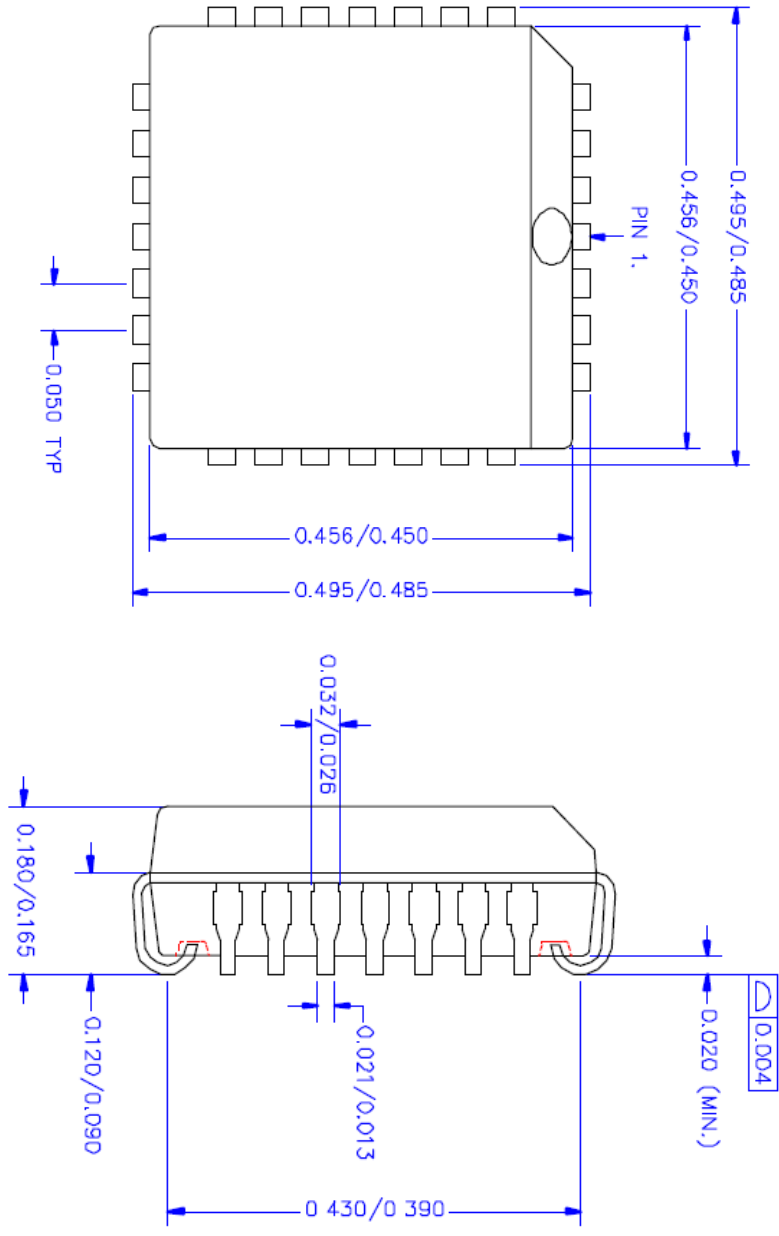

Figure 11 PLCC28

Characteristics

ABSOLUTE MAXIMUMS				
Symbol	Parameter	Min.	Max.	Units
T _A	Ambient	-40	+85	°C
T _S	Storage Temperature	-55	+150	°C
V _{DD}	Supply Voltage	2.7	5.5	V
V _{IN} , V _{OUT}	DC Input, Output	-0.3	VDD+0.3	V
T _L	Lead Temperature (soldering)		250	°C

DC CHARACTERISTICS						
(VDD = 2.7V to 5.5V, VSS = 0V, TA = -40C to +85C)						
Symbol	Parameter	VDD	Min.	Typical	Max.	Units
V _{IL}	Input Voltage, Low	2.7-5.5V			0.3*VDD	V
V _{IL}	INRESET、INRTS	2.7-3.3V	0.9	1.2	1.4	V
V _{IH}	Input Voltage	2.7-5.5V	0.7*VDD			V
V _{IH}	INRESET、INRTS	2.7-3.3V	1.3	1.8	2.3	V
V _{OL}	Output Voltage, Low (IOL = -1.8mA)	2.7-3.3V			0.4	V
V _{OH}	Output Voltage, High (IOH = -1.8mA)	2.7-3.3V	VDD-1.0			V
C _{IN}	Input Capacitance Analog Input IRXA Digital Input		2.1 20.8 3.1			pF
I _{IL/IH}	Input Leakage Current				±5	μA
I _{OLL}	Output Leakage Current				±5	μA
I _{DD}	Power Supply Current (RBIAS=500kΩ, IAREF=1.235V)	3.3 5.0			170 200	μA
IAREF	Analog Reference	3.3 5.0	1.2	1.235 2.5	2.6	V
ICDREF	Carrier Detect Reference (IAREF=.08V)			1.15		V
OCBIAS	Comparator Bias Current (RBIAS=500kΩ, IAREF=1.235V)			2.5		μA

AC CHARACTERISTICS					
(VDD = 2.7V to 5.5V, VSS = 0V, TA = -40C to +85C)					
Pin Name	Description	Min.	Typical	Max.	Units
IRXA	Receive Analog Input Leakage Current			+/-150	nA
	Frequency-Mark(Logic 1)	1190	1200	1210	Hz
	Frequency-Space(Logic 0)	2180	2200	2220	Hz
ORXAF	Output of the High-pass Filter Slew Rate		0.025		V/ μ s
	Gain Bandwidth (GBW)	150			kHz
	Voltage Range	0.15		VDD-0.15	V/ μ s
IRXAC	Carrier Detect & Receive Filter Input Leakage Current			+/-500	nA
OTXA	Modulator Output Frequency-Mark(Logic1)		1196.9		Hz
	Frequency-Space(Logic0)		2194.3		Hz
	Amplitude(IAREF1.235V)		500		mV p-p
	Slop		2.84		mV/ μ s
	Loading(IAREF=1.235V)	30			k Ω
ORXD	Receive Digital Output Rise/Fall Time	20			ns
	OCD	Carrier Detect Output Rise/Fall Time	20		ns

MODEM CHARACTERISTIC				
(VDD = 2.7V to 5.5V, VSS = 0V, TA = -40 C to +85 C)				
Parameter	Min.	Typical	Max.	Units
Demodulator Jitter Conditions 1.Input frequencies at 1200Hz+/-10Hz, 2200Hz+/-20Hz 2.Clock frequency of 460.8kHz+/-0.1% 3.Input(HLXA) asymmetry, 0			12	% of 1 bit

CERAMIC RESONATOR - EXTERNAL CLOCK SPECIFICATIONS				
(VDD = 2.7V to 5.5V, VSS = 0V, TA = -40 C to +85 C)				
Parameter	Min.	Typical	Max.	Units
Resonator Tolerance			1%	%
Frequency		460.8		kHz
External Clock Frequency	456.2	460.8	465.4	kHz
Duty Cycle	40	50	60	%
Amplitude		$V_{OH}-V_{OL}$		V