



## Precision Compact Ovens with Mechanical Convection

Operating and Parts List LTM1881X1 Rev. 2

Visit us online to register your warranty  
[www.thermoscientific.com/labwarranty](http://www.thermoscientific.com/labwarranty)

**Thermo**  
SCIENTIFIC

<b>Models covered in this manual</b>		
<b>Models</b>	<b>Size</b>	<b>Voltage</b>
PR305220M (665)	1.7 cu ft	240V
PR305225M (666)	1.7 cu ft	120V
PR305220MCN (670)	1.7 cu ft	240V

**MANUAL NUMBER LTM1881X1 (7000665)**

<b>REV</b>	<b>ECR/ECN</b>	<b>DATE</b>	<b>DESCRIPTION</b>	<b>By</b>
2	40434	8/10/15	Added installation ventilation distances needed - pg 3-2	ccs
1	31325	2/16/15	Added explosion and fire warning	ccs
0	--	4/30/10	Transfer to Marietta (was LTM1881X1 8/4/09)	ccs



**Important** Read this instruction manual. Failure to read, understand and follow the instructions in this manual may result in damage to the unit, injury to operating personnel, and poor equipment performance. ▲

**Caution** All internal adjustments and maintenance must be performed by qualified service personnel. ▲

Material in this manual is for information purposes only. The contents and the product it describes are subject to change without notice. Thermo Fisher Scientific makes no representations or warranties with respect to this manual. In no event shall Thermo be held liable for any damages, direct or incidental, arising out of or related to the use of this manual.

©2010 Thermo Scientific. All rights reserved.



Important operating and/or maintenance instructions. Read the accompanying text carefully.



Potential electrical hazards. Only qualified persons should perform procedures associated with this symbol.



Equipment being maintained or serviced must be turned off and locked off to prevent possible injury.



Hot surface(s) present which may cause burns to unprotected skin, or to materials which may be damaged by elevated temperatures.



Marking of electrical and electronic equipment, which applies to electrical and electronic equipment falling under the Directive 2002/96/EC (WEEE) and the equipment that has been put on the market after 13 August 2005.



This product is required to comply with the European Union's Waste Electrical & Electronic Equipment (WEEE) Directive 2002/96/EC. It is marked with the WEEE symbol. Thermo Fisher Scientific has contracted with one or more recycling/disposal companies in each EU Member State European Country, and this product should be disposed of or recycled through them. Further information on Thermo's compliance with this directive, the recyclers in your country and information on Thermo Scientific products will be available at [www.thermoscientific.com](http://www.thermoscientific.com).

- ✓ Always use the proper protective equipment (clothing, gloves, goggles, etc.)
- ✓ Always dissipate extreme cold or heat and wear protective clothing.
- ✓ Always follow good hygiene practices.
- ✓ Each individual is responsible for his or her own safety.

## Do You Need Information or Assistance on Thermo Scientific Products?

If you do, please contact us 8:00 a.m. to 6:00 p.m. (Eastern Time) at:

1-740-373-4763

1-800-438-4851

1-877-213-8051

<http://www.thermoscientific.com>

[service.led.marietta@thermofisher.com](mailto:service.led.marietta@thermofisher.com)

[www.unitylabservices.com](http://www.unitylabservices.com)

Direct

Toll Free, U.S. and Canada

FAX

Internet Worldwide Web Home Page

Tech Support Email Address

Certified Service Web Page

Our **Sales Support** staff can provide information on pricing and give you quotations. We can take your order and provide delivery information on major equipment items or make arrangements to have your local sales representative contact you. Our products are listed on the Internet and we can be contacted through our Internet home page.

Our **Service Support** staff can supply technical information about proper setup, operation or troubleshooting of your equipment. We can fill your needs for spare or replacement parts or provide you with on-site service. We can also provide you with a quotation on our Extended Warranty for your Thermo Scientific products.

Whatever Thermo Scientific products you need or use, we will be happy to discuss your applications. If you are experiencing technical problems, working together, we will help you locate the problem and, chances are, correct it yourself...over the telephone without a service call.

When more extensive service is necessary, we will assist you with direct factory trained technicians or a qualified service organization for on-the-spot repair. If your service need is covered by the warranty, we will arrange for the unit to be repaired at our expense and to your satisfaction.

Regardless of your needs, our professional telephone technicians are available to assist you Monday through Friday from 8:00 a.m. to 6:00 p.m. Eastern Time. Please contact us by telephone or fax. If you wish to write, our mailing address is:

Thermo Fisher Scientific  
401 Millcreek Road, Box 649  
Marietta, OH 45750

International customers, please contact your local Thermo Scientific distributor.

# Table of Contents

<b>Section 1</b>	<b>Introduction</b> .....	<b>1-1</b>
<b>Section 2</b>	<b>Specifications</b> .....	<b>2-1</b>
<b>Section 3</b>	<b>Unpacking and Installation</b> .....	<b>3-1</b>
	Location .....	3-2
	Leveling .....	3-2
	Shelving .....	3-2
	Electrical Connection .....	3-2
	Be Advised .....	3-2
<b>Section 4</b>	<b>Operation</b> .....	<b>4-1</b>
	Temp Control (Thermostat) .....	4-2
<b>Section 5</b>	<b>Maintenance</b> .....	<b>5-1</b>
	Care and Cleaning of Stainless Steel .....	5-1
	Some Stainless Guidelines to Consider .....	5-2
	Special Considerations .....	5-2
	The pH Factor .....	5-2
	Cleaning Methods .....	5-3
	Cleansing Agents .....	5-3
	Failure to Heat .....	5-4
	Part Replacement Procedures .....	5-4
	Replacing Thermostat .....	5-4
	Replacing Power Switch .....	5-5
	Replacing Heater .....	5-6
	Replacing Hi-Limit Thermostat .....	5-6
	Replacing Status Lamp Bulb Assembly .....	5-6
	Replacing the Blower Motor .....	5-7
	Replacing Blower Wheel: Servicing .....	5-7
	Temperature Readout Calibration .....	5-8
<b>Section 6</b>	<b>Replacement Parts</b> .....	<b>6-1</b>
	Ordering Procedures .....	6-2



# Section 1 Introduction

Thank you for selecting Thermo Scientific products for your equipment needs.

Thermo Scientific Precision Compact Ovens with mechanical convection are designed for use in industry, hospitals, school laboratories; wherever there is a need for economical and reliable ovens for drying, sterilizing, baking, evaporating and similar type work.

A hydraulic thermostat provides reliable temperature control with a range from 56C above ambient to 210°C. A sheathed heater is positioned in the bottom of the chamber along with a constant-speed fan that circulates heated air rapidly throughout the chamber. The metal cover shields the fan and protects against splattering in the event that any material is accidentally spilled in the area of the fan.

Chamber temperature is conveniently monitored via an LED display on the control panel. To guard against over-temperature conditions, a factory-set hi-limit thermostat is an integral part of the electrical system.

One-inch thick silica-based insulation in the double-walls of the chamber helps retain chamber heat. The interior walls of the chamber are stainless steel and the shelves are chrome-plated steel for ease of maintenance and clean up.

Precision Compact Ovens have a steel exterior finished in baked enamel and are rigidly constructed for long, troublefree service.

These instructions contain important operating and safety information. The user must carefully read and understand these instructions before using the oven. Your unit has been designed to optimize function, reliability, safety and ease of use. It is the user's responsibility to install the oven in conformance with local electrical codes.





## Section 2 Specifications

### Power Requirements

Model PR305225M: . . . .120 Volts, 50/60 Hz, 10 Amps, 1200 Watts

Model PR305220M, PR305220MCN: . . . .240 Volts, 50/60 Hz, 5  
Amps, 1200 Watts

### Overall Dimensions

18-7/16"W x 13-9/16"D x 25"H (47 x 40 x 64 cm)

### Chamber Dimensions

16"W x 11½" D x 16-1/8"H (41 x 29 x 41 cm)

### Volume

1.7 cu. ft. (48.1 liters)

### Shipping Weight

65 lbs. (30 kg)

### Performance Characteristics

Temperature Range . . . . .All models ambient +5°C to 210°C

Thermostat Control . . . . .±5% over entire range

Thermometer, Digital . . . . .±2°C over entire range

### Environmental Operating Conditions

Pollution Degree\*: . . . . .2

Installation Category\*: . . . . .II

Altitude: . . . . .2000 Meters MSL (Mean Sea Level)

Humidity: . . . . .80% maximum, non-condensing

Electrical Supply: . . . . .120VAC or 240VAC

Voltage Tolerance: . . . . .±10% of normal rated line

Temperature: . . . . .15°C to 40°C

Product Usage: This product is intended for use indoors only

*\*Refer to IEC 664-1*



## Section 3 Unpacking and Installation

The shipping carton should be inspected upon delivery. When received, carefully examine for any shipping damage before unpacking. If damage is discovered, the delivering carrier should both specify and sign for the damage on your copy of the delivery receipt.

Open the carton carefully, making certain that all parts are accounted for before packaging materials are discarded. After unpacking, if damage is found, promptly report it to the carrier and request a damage inspection promptly.

**Important** Failure to request an inspection of damage within a few days after receipt of shipment absolves the carrier from any liability for damage. Call for a damage inspection promptly.

**Warning** Do not place oven on or near any combustible surface to avoid the possibility of fire and resulting property loss and injury or death to personnel. ▲

**Caution** Do not remove the rubber space feet. Removal of the feet will prevent proper air venting (air used to cool the electronics is discharged out the bottom) of oven chamber that may cause excessive heat buildup on electrical components and erratic control of temperature. ▲

**Caution** Bottom shelf is fixed in place to guard against access to heater area and possibility of injury. Do not remove bottom shelf unless performing maintenance or repair. ▲

**Note** Disconnect unit from the power source when not in use.

**Location** The oven should be located in an area free from drafts and sources of heat, as well as allowing for natural air movement to dissipate heat from the oven. To ensure needed ventilation around the oven, allow 1.5 inches on each side and 3 inches at the back. Allow enough distance above the unit to be able to install and retrieve the thermometer.

**Leveling** The oven should be on a level surface, in order to facilitate movement of materials into and out from the chamber.

**Shelving** Slide shelves into place inside the oven and position according to the height required for the items or materials to be heated.

## **Electrical Connection**

The 120V unit is supplied with a 3-wire line cord with molded plug. It should be connected to a 120V outlet designed for 3-prong plugs. For an outlet designed to accept 2-prong plugs (ungrounded), the best advice is to have a qualified electrician replace it with a new, grounded outlet.

If a plug must be installed, use only the 3-prong grounded type, rated for the unit load requirements and matching the power outlet. Make sure the green ground wire is secured to the plug ground terminal.

The unit must be connected to a power source that meets the electrical requirements as specified on the unit's nameplate.

**Be Advised** Where it becomes necessary to make changes in electrical outlets, wiring and other characteristics, it is recommended that these be done by a qualified or journeyman electrician. This includes replacing 2-prong plugs (ungrounded), for example with a 3-prong plug (grounded).

All changes need to be made to match the load requirements shown on the nameplate of the unit.

**Warning** This unit is not explosion-proof. Do not use in the presence of flammable or combustible materials; fire or explosion may result. Unit contains components that may ignite such materials. Before operating oven, always observe the following safety precautions:

- Fumes and spillage from acidic solutions cause corrosion of the stainless steel chamber. Maintain a neutral pH at all times.
- The oven heater is in the bottom of the unit. Surface temperatures at the bottom cover of the unit may be higher than set point temperature. For example: A plastic container on the heater cover may become hot enough to melt/burn the container at settings below the melting point of plastic. Do not place items on the heater cover.

## Section 4 Operation

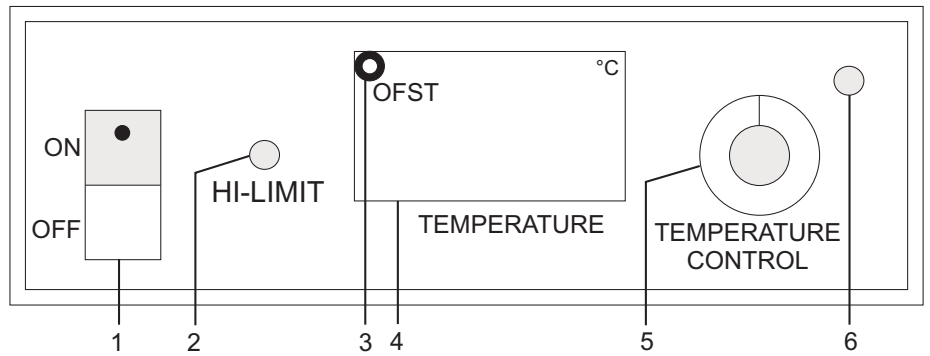

**Figure 4-1.** Control Panel

1. POWER SWITCH: Turns unit on (green status lamp lights) and off.
2. HI-LIMIT STATUS LAMP: Lights when the hi-limit thermostat is activated. It goes out when oven reverts to a safe operating range.
3. CALIBRATION POTENTIOMETER: Utilizing a jeweler's screwdriver, the temperature readout can be adjusted.
4. LED DISPLAY: Displays current chamber temperatures.
5. TEMPERATURE CONTROL (THERMOSTAT): Raises and lowers temperatures.
6. HEATERS STATUS LAMP: Lights when heaters are energized.

**Warning** Do not use in the presence of flammable or combustible materials or explosive gases. Do not use in the presence of pressurized or sealed containers - fire or explosion may result, causing death or severe injury. ▲

**Caution** It is the user's responsibility to monitor oven action when setting and maintaining operating temperature; oven failure may occur with possible property damage and/or injury to personnel. ▲

## Temp Control (Thermostat)

Refer to Figure 4-1 for the procedure below.

1. With the temperature control thermostat (5) in the extreme counterclockwise position, turn the power (rocker) (1) to its On position. (Switch's green status lamp will light.)
2. Turn the temperature control thermostat (5) in clockwise direction to increase the temperature and counterclockwise to lower it. The amber status lamp (6) above the thermostat goes on when the heaters are energized. Wait for the chamber temperature to stabilize before advancing thermostat too rapidly to reach target temperature. Note that dial setting to obtain a specific temperature will need to be approximated and can be affected by such factors as changes in line voltage, ambient conditions and types of materials being heated.
3. Read the LED display (4) for the chamber temperature produced by each setting of the temperature control thermostat (5). As experience is gained with the temperature control thermostat, improved results will be obtained in setting it to achieve specific target temperatures.
4. Always allow time for the oven to reach target temperature and to stabilize before making further adjustments of the temperature control thermostat.

**Caution** At the higher temperatures, the exterior of the oven and particularly the vent ring on the top of the oven become warm to the touch. To avoid burns, do not touch these surfaces.

- A factory-set hi-limit thermostat cuts off power to the heater in the event that the maximum operating range is exceeded. The red status lamp (2) on the control panel indicates when the hi-limit thermostat is controlling. It goes out when oven reverts to a safe operating range.

## Section 5 Maintenance

The bottom shelf that covers the heater can be removed for easy access to the heater area.

Clean up any spills as soon as possible to prevent materials being baked on surfaces. When the oven is cool, use a mild soap and water to clean surfaces. Rinse thoroughly and dry. It is best to avoid highly abrasive cleaners which can damage the finish of the interior surfaces and shelves.

**Warning** Disconnect plug from electrical outlet before attempting any maintenance or repair of this unit. ▲

**Note** Make no attempt to service or repair a Thermo Scientific product under warranty before consulting your Thermo dealer. After the warranty period, such consultation is still advised, especially when the repair may be technically sophisticated or difficult. If assistance is needed beyond what the distributor can provide, please call Technical Services. No merchandise should be returned directly to the factory without obtaining a Return Materials Authorization (RMA) number from Technical Services. ▲

### Care and Cleaning of Stainless Steel

Stainless steel is an alloy of steel with chromium and nickel that increase the metal's resistance to rust and corrosion. Yet, if not properly cared for, stainless steel can rust and corrode.

Exposure to air provides the passivation, or oxide layer coating, for clean stainless by producing a thin, durable chromium-oxide that forms rapidly on the alloy surface to give stainless its characteristic "stainless" quality. Also exposure of the surface to other oxidizing environments can produce a passivating film or coating.

However, if free oxygen is not available due to scale or contamination buildup, the metal surface may become vulnerable to rusting and corrosion as well as pitting. But by maintaining neutral pH and conducting frequent cleanings with detergent and water, years of trouble-free service from stainless steel products can be obtained.



## Care and Cleaning of Stainless Steel (cont.)

**Warning** Electrolysis can damage stainless steel. This occurs when an object is allowed to rest directly on the surface of stainless steel, trapping moisture that becomes oxygen-starved, but is surrounded by water-containing oxygen.

### Some Stainless Guidelines to Consider

Distilled water is recommended. Please note, if this water is very pure, it may be corrosive to stainless. When filling a bath or incubator, always add 2 to 40 PPM (20 to 40 mg/liter) diodium phosphate or sodium bicarbonate, adjusting dosage to provide a pH value of 7 to 9. If not available, use clean, aerated soft tap water provided the total solids concentration is < 500 PPM. We do not recommend using 18M Ohm deionized water. If this is the only source of treated water available, mix with regular tap water at a 50/50 ratio.

### The pH Factor

Check pH regularly. If pH is <6.0, add disodium phosphate to increase pH to a 7 to 9 value. Sodium carbonate or sodium bicarbonate may be used but they tend to form scale that must be rinsed out regularly. If pH is >10.0, add sodium bisulfate to decrease pH to a 7 to 9 value. Avoid adding harsh alkalines or acids since these may cause localized corrosion and result in unstable pH.

### Special Considerations

Chemicals which should be limited to a 3 hour maximum exposure time to stainless steel are:

<b>Aluminum chloride</b>	<b>E.D.T.A.</b>	<b>Potassium permanganate</b>
<b>Barium chloride</b>	<b>Ferrous chloride</b>	<b>Potassium thiocyanate</b>
<b>Calcium chloride</b>	<b>Lysol</b>	<b>Sodium hypochlorite</b>
<b>Chlorinated Lime</b>	<b>Mercury salts</b>	<b>Stannous chloride</b>
<b>Citric acid (boiling)</b>	<b>Phenol</b>	<b>Tartaric acid</b>
<b>Dakin's solution</b>		

**Warning** If it is necessary to use these chemicals, limit exposure time to a maximum of 3 hours - always clean surfaces immediately after use. ▲

Be advised: **Never** use the following on stainless steel:

<b>Aqua regia</b>	<b>Ferric chloride</b>	<b>Iodine</b>
<b>Sodium acid</b>	<b>Sodium azide</b>	

Chemical spills, especially those agents listed here, should be removed as soon as possible and the stainless steel surface cleaned with mild soapy water followed by a clean water rinse.

## **Cleansing Agents**

Anti-fungal and anti-bacterial additives are permissible to use as long as the pH of the aqueous solution is kept within the range of 7 to 9. These are available through laboratory distributors. Be sure to confirm that they are not harmful to stainless steel.

## **Cleaning Methods**

Do not use any metallic pads. Instead, for stubborn stains, use a plastic light-duty cleansing pad and rub gently in the direction of the metal grain. If stains continue to persist, use one of the following chemicals and methods.

- Any of a variety of "scale removers" available at local supermarkets or hardware stores used for the cleaning of coffee marks, humidifiers or vaporizers.
- A 15% to 35% phosphoric acid solution available from laboratory supply distributors for scale and rust removal. Allow solution to soak the surface affected until rust and scale is loosened. Immediately follow with a clean water rinse.
- Citric acid based cleaners.
- Bathroom tub and tile cleaners.

Regardless of the approach utilized, always follow the manufacturer's directions and allow the chemicals to do the cleaning with minimal scrubbing.

Always follow cleanings with a clean water rinse. Air dry.

**Caution** Extreme care must be taken when handling these materials. Always work in an area with adequate ventilation. Use the precautions as outlined in the Material Safety Data Sheet (MSDS) and the manufacturer's instructions for the product being utilized. Also, follow the personal protection index found in the Hazardous Materials Information System (HMIS) section of the MSDS. ▲

**Note** The use and disposal of these chemicals may be regulated by your local city codes; consult those regulations before of disposing of those materials. ▲

### **Materials Effective in Disinfecting**

- Glutaraldehyde
- Alcohol

**Be Advised:** This information is intended as guidelines only and we make no claim as to the suitability to any particular situation. Consult your staff chemist to determine what would be best for your stainless steel product and laboratory. ▲

### **Failure to Heat**

If the oven fails to heat, there are several possible causes:

- The oven is not receiving electrical power.
- The heater is burned out.
- The thermostat is malfunctioning.

Have a qualified electrical technician determine the cause of the problem and make the necessary repairs.

### **Part Replacement Procedures**

The following should be performed only by authorized personnel.

Unplug unit from power source. If oven has been used recently, be certain that surfaces are safe to touch before attempting to carry out any of the following procedures. Remove contents of oven and thermometer from top of unit.

### **Replacing Thermostat**

1. Place unit on its side with door latch facing down.
2. Remove back by unscrewing Phillips screws. Save.
3. Carefully remove insulation. Note how it is positioned, so that it can be easily reinstalled.
4. Remove bottom panel by unscrewing Phillips screws. Save.
5. Remove control knob by unscrewing 2 Allen screws. Save.
6. Disconnect wires from thermostat. Note position of wires for subsequent reattachment in same sequence.

## **Replacing Thermostat (continued)**

7. Knob removal allows access to 2 screws that mount thermostat to panel. Remove the screws and save.
8. Remove bottom shelf inside chamber. Loosen screw on clamp that holds thermostat-sensing bulb to heater. Note position of temperature sensing bulb, so that new one can be clamped in same location.
9. Slide bulb toward exit hole at the back of unit.
10. Move to back of unit and pull temperature sensing bulb and tube through hole.
11. Next, pull bulb and tube through bottom hole.
12. Thermostat, sensing bulb and tube assembly can now be removed.
13. Reverse above procedure to install new thermostat.
14. Avoid making sharp bends in temperature sensing tube; otherwise, flow of temperature sensing fluid will be impeded.

## **Replacing Power Switch**

1. With unit on its side as in the preceding, remove bottom plate and save screws.
2. Disconnect wires from switch. Note sequence of pin numbers on the side of the switch and attachment of wires. The replacement switch must be oriented in the same manner and wires attached in same sequence.
3. Compress holding tabs on switch and push out.
4. Insert new switch from the front. When inserting, follow same orientation of pin numbers as on the switch just removed.
5. Attach wires in SAME SEQUENCE as originally attached. To verify that correct sequence has been followed, refer to wiring schematic.
6. Reverse remainder of procedure.

## **Replacing Status Lamp Bulb Assembly**

1. With unit on its side as in the preceding, remove bottom plate and save screws.
2. Note plastic lamp unit that houses bulb. Be alert that lens will pop out in next step.
3. Grasp lamp unit and pull a fraction of an inch toward the attached wires. Lens will pop out the front. Save.
4. Cut wires and remove lamp unit. Discard.
5. To install new pilot lamp unit, splice the two wires of the assembly to previously cut wires using insulated crimp connectors.
6. Re-install lens.
7. Re-install bottom plate.

## **Replacing Hi-Limit Thermostat**

1. Remove back panel and carefully remove insulation for subsequent reinstallation. Save.
2. Hi-limit thermostat is mounted on back of inner chamber wall.
3. Unscrew 2 screws and nuts holding wires. Save.
4. Remove screw securing thermostat to back of inside wall.
5. Reverse preceding procedure to install a new hi-limit thermostat.

## **Replacing Heater**

1. Heater is located in bottom of chamber. Be sure that unit has been turned off for a period of time, so that there is no residual heat on any of the surfaces.
2. Remove back panel by unscrewing Phillips screws and save.
3. Carefully remove insulation and save. Note how it is positioned, so that it can be easily reinstalled.
4. Remove two retaining clips that mount heater to back of inside wall. Save.
5. Remove wires to heater by uncoupling the quick-disconnects.
6. Remove bottom shelf inside chamber. Loosen screw on clamp which holds thermostat sensing bulb to heater. Note position of temperature sensing bulb, so that new one can be clamped in same location.
7. Install new heater and reverse the preceding steps.

## **Replacing Blower Wheel: Servicing**

1. Disconnect power cord.
2. Remove shelves. Note that bottom shelf is retained by a clip at the back of the oven. Lift shelf at the front edge until the back edge can be withdrawn from the clip.
3. Remove Phillips screws holding shield that covers blower wheel.
4. Inspect blower wheel assembly for tightness and any off-center operation. Inspect blower wheel itself for damage to vanes or other deterioration. If assembly is loose, tighten setscrew-holding wheel to motor shaft until wheel turns true. If wheel is damaged, replace.
5. Replace the shield and shelves.

## **Replacing the Blower Motor**

1. Disconnect unit from power source. If previously in use, let unit cool down.
2. Lay unit on side. Remove shelves, including the bottom one.
3. Remove bottom cover, fan shield and blower fan.
4. Accessing the unit from the bottom, remove motor and bracket assembly. Disconnect wires.
5. Remove shaft extension, bottom fan and motor bracket from old motor and reinstall on new, replacement motor.
6. Re-install motor assembly into unit in reverse order of removal.
7. Reconnect wires.
8. Re-install shelves. Make sure that bottom shelf is securely in place to prevent access to the heater area.

## Temperature Readout Calibration

A temperature readout calibration potentiometer (3) is located in the upper left hand corner of the LED display and is indicated by the word, "OFST." Use a jeweler's screwdriver to make adjustments.

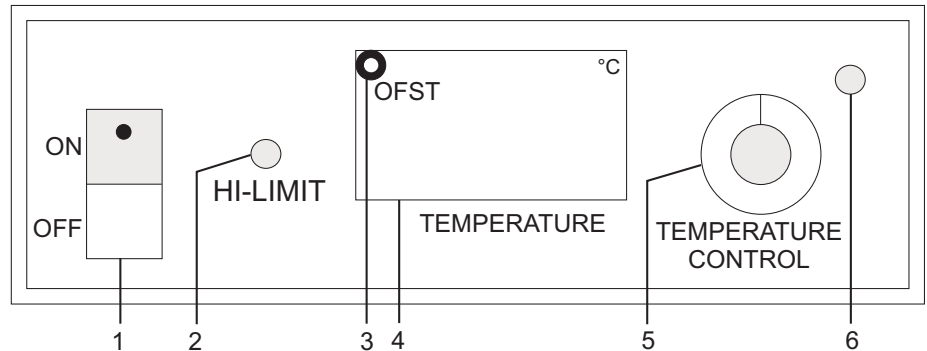

**Figure 5-1.** Control Panel

1. Have a digital thermometer, known reliable thermocouple (Type-K or-T) and the jeweler's screwdriver on hand.
2. Insert the thermocouple sensor through the outside top vent hole and position it in the center of the oven chamber.
3. Set oven temperature to a desired setpoint and turn on the power.
4. Allow temperature to stabilize for at least 2 hours before making any adjustments.
5. Compare the chamber temperature on the digital thermometer to the temperature on the oven readout.
6. Insert jeweler's screwdriver in calibration hole and adjust the oven readout to match the thermometer reading. Turn potentiometer clockwise to increase reading and counterclockwise to decrease it.
7. Take two additional readings within an approximate 30-minute time span and make any necessary adjustments to the potentiometer. This takes into account any temperature variations that might exist within the oven and the time delay in responding to such factors by the temperature sensors.

## Section 6 Replacement Parts

DESCRIPTION	PART NUMBER
Cordset, 120V	CR1483X1
Cordset, 240V	CR1483X2
Cordset, 240V China	CR1881X1
Door Catch	600-124-00
Door Handle	560-165-00
Fan, Axial (2)	160-136-00
Fan Shield	805-398-00
Feet, Rubber (4)	790-225-00
Fuse, 8 A, PR305220M, PR205220MCN (2)	790-225-00
Fuse, 15 A, PR305225M	330-298-00
Fuse Holder, PR305225M	330-297-00
Fuse Holder, PR305220M, PR205220MCN (2)	330-237-00
Gasket	530-196-00
Grommet (2)	790-247-00
Heaters:	
PR305225M, 120V	340-283-00
PR305220M, PR205220MCN, 240V	340-296-00
Knob, Thermostat	560-223-00
Motor, PR305225M 120V	MT1447X2
Motor, PR305220M, PR205220MCN 240V	MT1447X1
Shelves Kit	3515M-8Q
Status Lamp Base (2)	360-233-01
Status Lamp Lens, Amber	360-235-00
Status Lamp Lens, Red	360-234-00
Switch, Power, 120V	SWX143
Switch, Power, 240V	440-292-00
Temperature Sensor, RTD	410-667-00
Thermometer, Digital	910-126-00
Thermostat, Control	920-223-00
Thermostat, Hi-Limit	920-413-00



## **Ordering Procedures**

Refer to the Specification Plate for the complete model number, serial number, and series number when requesting service, replacement parts or in any correspondence concerning this unit.

All parts listed herein may be ordered from the Thermo Scientific dealer from whom you purchased this unit, or can be obtained promptly from the factory. When service or replacement parts are needed, check first with your dealer. If the dealer cannot process your request, then contact our Technical Services Department.

Prior to returning any materials, contact our Technical Services Department for a “Return Materials Authorization” number (RMA). Material returned without an RMA number will be refused.

**[thermoscientific.com](http://thermoscientific.com)**

© 2014 Thermo Fisher Scientific Inc. All rights reserved. All trademarks are the property of Thermo Fisher Scientific and its subsidiaries. Specifications, terms and pricing are subject to change. Not all products are available in all countries. Please consult your local sales representative for details.

**Thermo Fisher Scientific**  
401 Millcreek Road  
Marietta, Ohio 45750  
United States

**Thermo**  
S C I E N T I F I C  
A Thermo Fisher Scientific Brand