

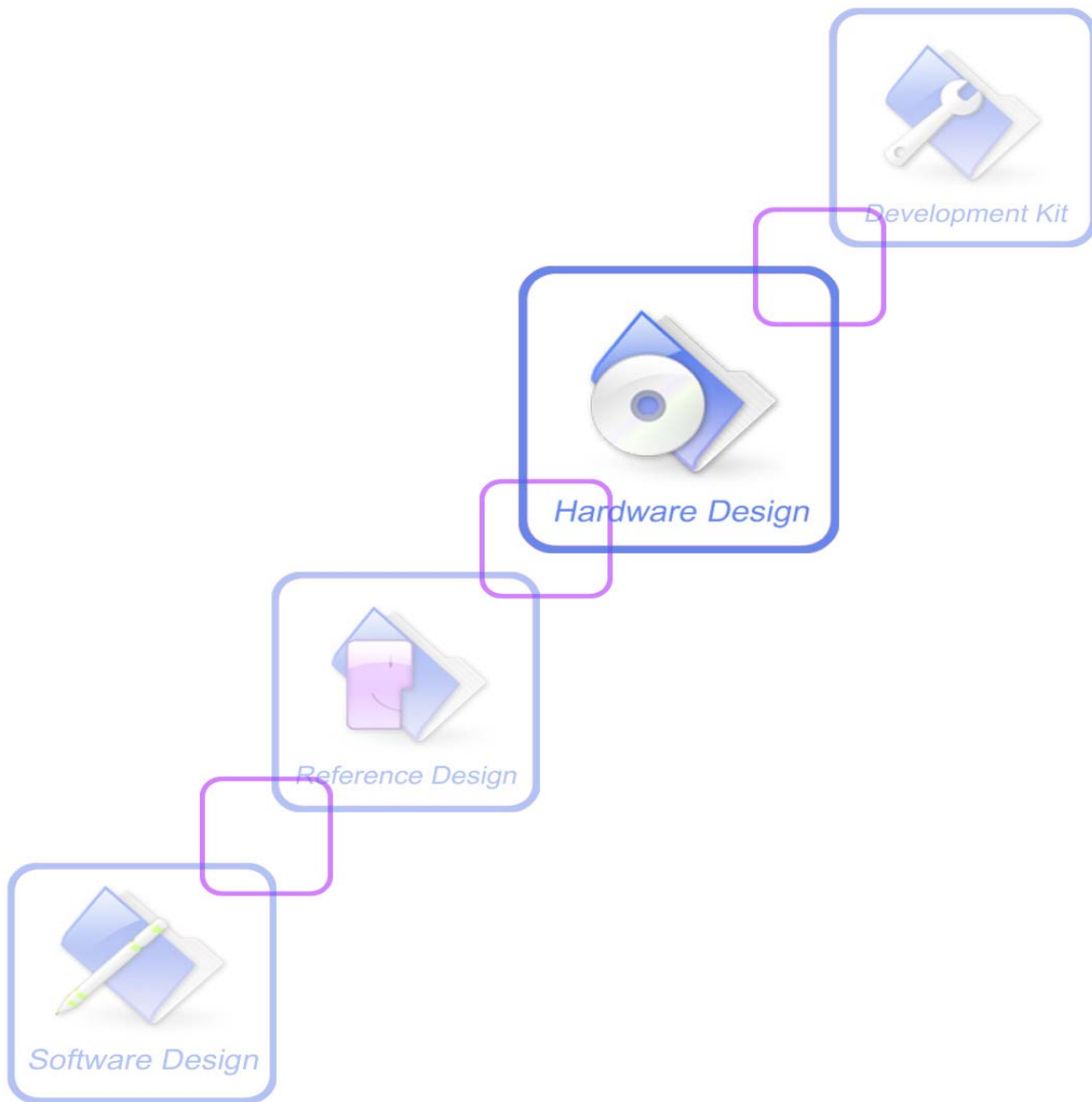

A company of SIM Tech

SIM900E_Hardware Design_V1.00



Document Title	SIM900E Hardware Design
Version	1.00
Date	2013-02-02
Status	Release
Document Control ID	SIM900E_Hardware Design_V1.00

General Notes

SIMCom offers this information as a service to its customers, to support application and engineering efforts that use the products designed by SIMCom. The information provided is based upon requirements specifically provided to SIMCom by the customers. SIMCom has not undertaken any independent search for additional relevant information, including any information that may be in the customer's possession. Furthermore, system validation of this product designed by SIMCom within a larger electronic system remains the responsibility of the customer or the customer's system integrator. All specifications supplied herein are subject to change.

Copyright

This document contains proprietary technical information which is the property of SIMCom Limited, copying of this document and giving it to others and the using or communication of the contents thereof, are forbidden without express authority. Offenders are liable to the payment of damages. All rights reserved in the event of grant of a patent or the registration of a utility model or design. All specification supplied herein are subject to change without notice at any time.

Copyright © Shanghai SIMCom Wireless Solutions Ltd. 2012

Contents

Contents	3
Version History	7
1 Introduction	8
2 SIM900E Overview	8
2.1 SIM900E Key Features	8
2.2 Operating Modes	10
2.3 SIM900E Functional Diagram.....	11
3 Package Information	12
3.1 Pin out Diagram.....	12
3.2 Pin Description	13
3.3 Package Dimensions.....	15
4 Application Interface	18
4.1 Power Supply.....	18
4.1.1 Minimizing Voltage Drop of VBAT	19
4.1.2 Monitoring Power Supply	19
4.2 Power on/down Scenarios	19
4.2.1 Power on SIM900E	19
4.2.2 Power down SIM900E	20
4.2.3 Restart SIM900E by PWRKEY Pin	22
4.3 Power Saving Mode.....	22
4.3.1 Minimum Functionality Mode	22
4.3.2 Sleep Mode 1 (AT+CSCLK=1)	23
4.3.3 Wake Up SIM900E from Sleep Mode 1 (AT+CSCLK=1).....	23
4.3.4 Sleep Mode 2 (AT+CSCLK=2)	23
4.3.5 Wake Up SIM900E from Sleep Mode 2 (AT+CSCLK=2).....	24
4.4 RTC Backup.....	24
4.5 Serial Interfaces	25
4.5.1 Function of Serial Port and Debug Port	26
4.5.2 Software Upgrade and Debug	27
4.6 Audio Interfaces	27
4.6.1 Speaker Interface Configuration	27
4.6.2 Microphone Interfaces Configuration	28
4.6.3 Earphone Interface Configuration.....	29
4.6.4 Audio Electronic Characteristics.....	29
4.7 SIM Card Interface.....	30
4.7.1 SIM Card Application	30
4.7.2 Design Considerations for SIM Card Holder.....	31
4.8 LCD Display/SPI Interface.....	32
4.9 Keypad Interface	33
4.10 ADC.....	34
4.11 RI Behaviors.....	34
4.12 Network Status Indication	35

4.13	General Purpose Input/Output (GPIO)	36
4.14	External Reset.....	36
4.15	PWM	37
4.16	I ² C Bus.....	38
4.17	Antenna Interface	38
5	Electrical, Reliability and Radio Characteristics.....	39
5.1	Absolute Maximum Ratings	39
5.2	Recommended Operating Conditions.....	39
5.3	Digital Interface Characteristics	39
5.4	SIM Card Interface Characteristics	39
5.5	VDD_EXT Characteristics	40
5.6	SIM_VDD Characteristics.....	40
5.7	VRTC Characteristics	40
5.8	Current Consumption (VBAT = 3.8V)	41
5.9	Radio Characteristics.....	42
5.9.1	Module RF Output Power	42
5.9.2	Module RF Receive Sensitivity.....	43
5.9.3	Module Operating Frequencies	43
6	Manufacturing	44
6.1	Top and Bottom View of SIM900E.....	44
6.2	Typical Solder Reflow Profile.....	45
Appendix	47
A.	Related Documents.....	47
B.	Terms and Abbreviations	48
C.	Safety Caution	49

SIMCOM CONFIDENTIAL FILE

Table Index

TABLE 1: SIM900E KEY FEATURES	8
TABLE 2: CODING SCHEMES AND MAXIMUM NET DATA RATES OVER AIR INTERFACE	10
TABLE 3: OVERVIEW OF OPERATING MODES.....	10
TABLE 4: PIN DESCRIPTION	13
TABLE 5: THE CURRENT CONSUMPTION OF MINIMUM FUNCTIONALITY MODE	23
TABLE 6: MICROPHONE INPUT CHARACTERISTICS	29
TABLE 7: AUDIO OUTPUT CHARACTERISTICS	30
TABLE 8: PIN DESCRIPTION (AMPHENOL SIM CARD HOLDER).....	31
TABLE 9: PIN DESCRIPTION (MOLEX SIM CARD HOLDER)	32
TABLE 10: PIN DEFINITION OF THE KEYPAD INTERFACE.....	33
TABLE 11: ADC SPECIFICATION.....	34
TABLE 12: RI BEHAVIORS	34
TABLE 13: STATUS OF THE NETLIGHT PIN.....	35
TABLE 14: PIN DEFINITION OF THE GPIO INTERFACE	36
TABLE 15: ABSOLUTE MAXIMUM RATINGS.....	39
TABLE 16: RECOMMENDED OPERATING CONDITIONS	39
TABLE 17: DIGITAL INTERFACE CHARACTERISTICS	39
TABLE 18: SIM CARD INTERFACE CHARACTERISTICS.....	40
TABLE 19: VDD_EXT CHARACTERISTICS	40
TABLE 20: SIM_VDD CHARACTERISTICS.....	40
TABLE 21: VRTC CHARACTERISTICS.....	40
TABLE 22: CURRENT CONSUMPTION*	41
TABLE 23: SIM900E GSM 900 AND GSM 850 CONDUCTED RF OUTPUT POWER.....	42
TABLE 24: SIM900E DCS 1800 AND PCS 1900 CONDUCTED RF OUTPUT POWER	42
TABLE 25: SIM900E CONDUCTED RF RECEIVE SENSITIVITY.....	43
TABLE 26: SIM900E OPERATING FREQUENCIES	43
TABLE 27: ILLUSTRATION OF MODULE INFORMATION.....	44
TABLE 28: RELATED DOCUMENTS	47
TABLE 29: TERMS AND ABBREVIATIONS.....	48
TABLE 30: SAFETY CAUTION.....	49

Figure Index

FIGURE 1: SIM900E FUNCTIONAL DIAGRAM.....	11
FIGURE 2: SIM900E PIN OUT DIAGRAM (TOP VIEW).....	12
FIGURE 3: DIMENSIONS OF SIM900E (UNIT: MM)	15
FIGURE 4: RECOMMENDED PCB FOOTPRINT OUTLINE (UNIT: MM)	16
FIGURE 5: RECOMMENDED SMT STENCIL OUTLINE (UNIT: MM)	17
FIGURE 6: REFERENCE CIRCUIT OF THE LDO POWER SUPPLY	18
FIGURE 7: REFERENCE CIRCUIT OF THE DC-DC POWER SUPPLY	18
FIGURE 8: VBAT VOLTAGE DROP DURING TRANSMIT BURST.....	19
FIGURE 9: THE MINIMAL VBAT VOLTAGE REQUIREMENT AT VBAT DROP	19
FIGURE 10: POWERED ON/DOWN MODULE USING TRANSISTOR.....	19
FIGURE 11: POWERED ON/DOWN MODULE USING BUTTON	20
FIGURE 12: TIMING OF POWER ON MODULE.....	20
FIGURE 13: TIMING OF POWER DOWN SIM900E BY PWRKEY.....	21
FIGURE 14: TIMING OF RESTART SIM900E.....	22
FIGURE 15: RTC SUPPLY FROM CAPACITOR.....	24
FIGURE 16: RTC SUPPLY FROM NON-CHARGEABLE BATTERY	24
FIGURE 17: RTC SUPPLY FROM RECHARGEABLE BATTERY	24
FIGURE 18: SEIKO XH414H-IV01E CHARGE-DISCHARGE CHARACTERISTIC	25
FIGURE 19: CONNECTION OF THE SERIAL INTERFACES.....	25
FIGURE 20: CONNECTION OF RXD AND TXD ONLY	26
FIGURE 21: CONNECTION FOR SOFTWARE UPGRADING AND DEBUGGING	27
FIGURE 22: SPEAKER REFERENCE CIRCUIT	27
FIGURE 23: SPEAKER WITH AMPLIFIER REFERENCE CIRCUIT	28
FIGURE 24 : MICROPHONE REFERENCE CIRCUIT.....	28
FIGURE 25: EARPHONE REFERENCE CIRCUIT.....	29
FIGURE 26: REFERENCE CIRCUIT OF THE 8-PIN SIM CARD HOLDER.....	30
FIGURE 27: REFERENCE CIRCUIT OF THE 6-PIN SIM CARD HOLDER.....	31
FIGURE 28: AMPHENOL C707 10M006 5122 SIM CARD HOLDER.....	31
FIGURE 29: MOLEX 91228 SIM CARD HOLDER	32
FIGURE 30: REFERENCE CIRCUIT OF THE KEYPAD INTERFACE	33
FIGURE 31: RI BEHAVIOUR OF VOICE CALLING AS A RECEIVER.....	34
FIGURE 32: RI BEHAVIOUR OF DATA CALLING AS A RECEIVER.....	35
FIGURE 33: RI BEHAVIOUR OF URC OR RECEIVE SMS	35
FIGURE 34: RI BEHAVIOUR AS A CALLER	35
FIGURE 35: REFERENCE CIRCUIT OF NETLIGHT	36
FIGURE 36: RESET TIMING	37
FIGURE 37: RESET REFERENCE DESIGN CIRCUIT	37
FIGURE 38: ANTENNA MATCHING CIRCUIT	38
FIGURE 39: TOP, BOTTOM AND SIDE VIEW OF SIM900E.....	44
FIGURE 40: MODULE INFORMATION	44
FIGURE 41: STANDARD TEMPERATURE CURVE AND THE PARAMETER RANGE OF LEAD PROCESSES ..	45
FIGURE 42: STANDARD TEMPERATURE CURVE AND THE PARAMETER RANGE OF LEAD-FREE PROCESSES.....	46

Version History

Date	Version	Description of change	Author
2013-02-02	1.00	Origin	zhaojuntao Tenglili

SIMCOM CONFIDENTIAL FILE

1 Introduction

This document describes SIM900E hardware interface in great detail.

This document can help users to quickly understand SIM900E interface specifications, electrical and mechanical details. With the help of this document and other SIM900E application notes, user guide, users can use SIM900E to design various applications quickly.

2 SIM900E Overview

Designed for global market, SIM900E is a quad-band GSM/GPRS module that works on frequencies GSM 850MHz, EGSM 900MHz, DCS 1800MHz and PCS 1900MHz. SIM900E features GPRS multi-slot class 10/class 8 (optional) and supports the GPRS coding schemes CS-1, CS-2, CS-3 and CS-4.

With a tiny configuration of 19.8*19.8*2.7mm, SIM900E can meet almost all the space requirements in user applications, such as M2M, smart phone, PDA and other mobile devices.

SIM900E has 69 pads in a LGA package , and provides all hardware interfaces between the module and customers' boards.

- Serial port and debug port can help users to easily develop their applications.
- Audio channel which includes a microphone input and a receiver output.
- Programmable general purpose input and output.
- The keypad and SPI display interfaces will give users the flexibility to develop customized applications.

SIM900E is designed with power saving technique so that the current consumption is as low as 1.0mA in sleep mode.

SIM900E integrates TCP/IP protocol and extended TCP/IP AT commands which are very useful for data transfer applications. For details about TCP/IP applications, please refer to *document [2]*.

2.1 SIM900E Key Features

Table 1: SIM900E key features

Feature	Implementation
Power supply	3.2V ~ 4.8V
Power saving	Typical power consumption in sleep mode is 1.0mA (BS-PA-MFRMS=9)
Frequency bands	<ul style="list-style-type: none"> ● SIM900E Quad-band: GSM 850, EGSM 900, DCS 1800, PCS 1900. SIM900E can search the 4 frequency bands automatically. The frequency bands also can be set by AT command “AT+CBAND”. For details, please refer to <i>document [1]</i>. ● Compliant to GSM Phase 2/2+

Transmitting power	<ul style="list-style-type: none"> ● Class 4 (2W) at GSM 850 and EGSM 900 ● Class 1 (1W) at DCS 1800 and PCS 1900
GPRS connectivity	<ul style="list-style-type: none"> ● GPRS multi-slot class 10 (default) ● GPRS multi-slot class 8 (option)
Temperature range	<ul style="list-style-type: none"> ● Normal operation: -30°C ~ +80°C ● Restricted operation: -40°C ~ -30°C and +80 °C ~ +85°C* ● Storage temperature -45°C ~ +90°C
Data GPRS	<ul style="list-style-type: none"> ● GPRS data downlink transfer: max. 85.6 kbps ● GPRS data uplink transfer: max. 42.8 kbps ● Coding scheme: CS-1, CS-2, CS-3 and CS-4 ● Integrate the TCP/IP protocol. ● Support Packet Broadcast Control Channel (PBCCH)
CSD	<ul style="list-style-type: none"> ● Support CSD transmission
USSD	<ul style="list-style-type: none"> ● Unstructured Supplementary Services Data (USSD) support
SMS	<ul style="list-style-type: none"> ● MT, MO, CB, Text and PDU mode ● SMS storage: SIM card
FAX	Group 3 Class 1
SIM interface	Support SIM card: 1.8V, 3V
External antenna	Antenna pad
Audio features	<p>Speech codec modes:</p> <ul style="list-style-type: none"> ● Half Rate (ETS 06.20) ● Full Rate (ETS 06.10) ● Enhanced Full Rate (ETS 06.50 / 06.60 / 06.80) ● Adaptive multi rate (AMR) ● Echo Cancellation ● Noise Suppression
Serial port and debug port	<p>Serial port:</p> <ul style="list-style-type: none"> ● Full modem interface with status and control lines, unbalanced, asynchronous. ● 1200bps to 115200bps. ● Can be used for AT commands or data stream. ● Support RTS/CTS hardware handshake and software ON/OFF flow control. ● Multiplex ability according to GSM 07.10 Multiplexer Protocol. ● Autobauding supports baud rate from 1200 bps to 57600bps. <p>Debug port:</p> <ul style="list-style-type: none"> ● Null modem interface DBG_TXD and DBG_RXD. ● Can be used for debugging and upgrading firmware.
Phonebook management	Support phonebook types: SM, FD, LD, RC, ON, MC.
SIM application toolkit	GSM 11.14 Release 99
Real time clock	Support RTC
Physical characteristics	<p>Size: 19.8*19.8*2.7mm</p> <p>Weight: 2.2g</p>
Firmware upgrade	Firmware upgradeable by debug port.

*SIM900E does work at this temperature, but some radio frequency characteristics may deviate from the GSM specification.

Table 2: Coding schemes and maximum net data rates over air interface

Coding scheme	1 timeslot	2 timeslot	4 timeslot
CS-1	9.05kbps	18.1kbps	36.2kbps
CS-2	13.4kbps	26.8kbps	53.6kbps
CS-3	15.6kbps	31.2kbps	62.4kbps
CS-4	21.4kbps	42.8kbps	85.6kbps

2.2 Operating Modes

The table below summarizes the various operating modes of SIM900E.

Table 3: Overview of operating modes

Mode	Function
Normal operation	GSM/GPRS SLEEP Module will automatically go into sleep mode if the conditions of sleep mode are enabling and there is no on air and no hardware interrupt (such as GPIO interrupt or data on serial port). In this case, the current consumption of module will reduce to the minimal level. In sleep mode, the module can still receive paging message and SMS.
	GSM IDLE Software is active. Module registered to the GSM network, and the module is ready to communicate.
	GSM TALK Connection between two subscribers is in progress. In this case, the power consumption depends on network settings such as DTX off/on, FR/EFR/HR, hopping sequences, antenna.
	GPRS STANDBY Module is ready for GPRS data transfer, but no data is currently sent or received. In this case, power consumption depends on network settings and GPRS configuration.
	GPRS DATA There is GPRS data transfer (PPP or TCP or UDP) in progress. In this case, power consumption is related with network settings (e.g. power control level); uplink/downlink data rates and GPRS configuration (e.g. used multi-slot settings).
Power down	Normal power down by sending the AT command “AT+CPOWD=1” or using the PWRKEY. The power management unit shuts down the power supply for the baseband part of the module, and only the power supply for the RTC is remained. Software is not active. The serial port is not accessible. Power supply (connected to VBAT) remains applied.
Minimum functionality mode	AT command “AT+CFUN” can be used to set the module to a minimum functionality mode without removing the power supply. In this mode, the RF part of the module will not work or the SIM card will not be accessible, or both RF part and SIM card will be closed, and the serial port is still accessible. The power consumption in this mode is lower than normal mode.

2.3 SIM900E Functional Diagram

The following figure shows a functional diagram of SIM900E:

- The GSM baseband engine
- Flash
- The GSM radio frequency part
- The antenna interface
- The other interfaces

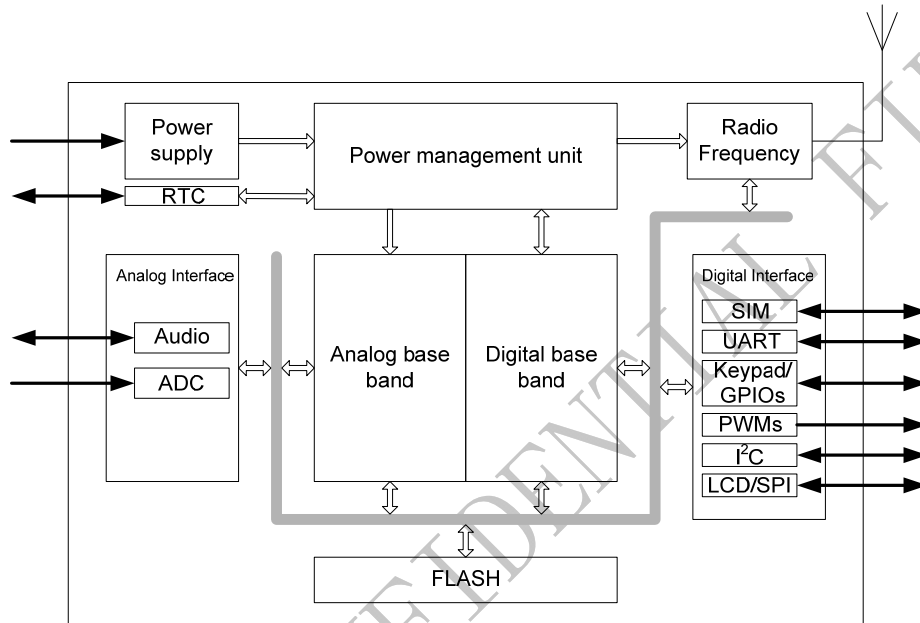

Figure 1: SIM900E functional diagram

3 Package Information

3.1 Pin out Diagram

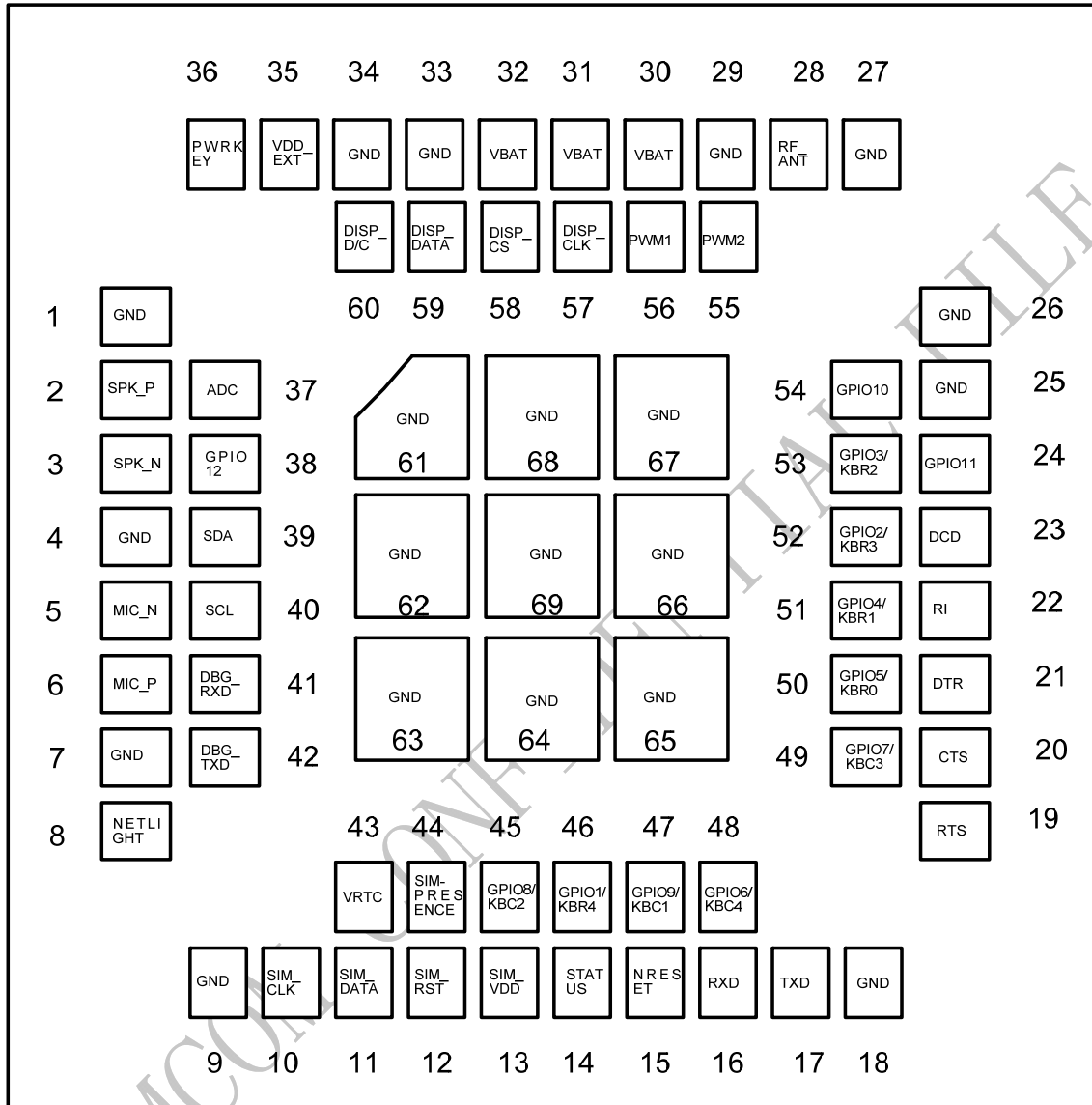

Figure 2: SIM900E pin out diagram (Top view)

3.2 Pin Description

Table 4: Pin description

Pin name	Pin number	I/ O	Description	Comment
Power supply				
VBAT	30,31,32	I	Power supply	
VRTC	43	I/ O	Power supply for RTC	It is recommended to connect with a battery or a capacitor (e.g. 4.7uF).
VDD_EXT	35	O	2.8V output power supply	If it is unused, keep open.
GND	1,4,7,9,18,25,26, ,27,29,33,34, 61,62,63,64,65, 66,67,68,69		Ground	
Power on/down				
PWRKEY	36	I	PWRKEY should be pulled low at least 1 second and then released to power on/down the module.	Pulled up internally.
Audio interfaces				
MIC_P	6	I	Differential audio input	If these pins are unused, keep open.
MIC_N	5			
SPK_P	2	O	Differential audio output	
SPK_N	3			
Status				
STATUS	14	O	Power on status	If these pins are unused, keep open.
NETLIGHT	8	O	Network status	
LCD interface				
DISP_CLK	57	O	Display interface	If these pins are unused, keep open.
DISP_DATA	59	I/ O		
DISP_D/C	60	O		
DISP_CS	58	O		
I²C interface				
SDA	39	O	I ² C serial bus data	If these pins are unused, keep open.
SCL	40	I/ O	I ² C serial bus clock	
Keypad interface / GPIOs				
GPIO5/KBR0	50	I/	GPIO5/keypad row 0	If these pins are unused,

GPIO4/KBR1	51	O	GPIO4/keypad row 1	keep open.
GPIO3/KBR2	53		GPIO3/keypad row 2	
GPIO2/KBR3	52		GPIO2/keypad row 3	
GPIO1/KBR4	46		GPIO1/keypad row 4	
GPIO9/KBC1	47		GPIO9/keypad column 1	
GPIO8/KBC2	45		GPIO8/keypad column 2	
GPIO7/KBC3	49		GPIO7/keypad column 3	
GPIO6/KBC4	48		GPIO6/keypad column 4	
GPIO10	54		GPIO10	
GPIO11	24		GPIO11	
GPIO12	38		GPIO12	
Serial port				
RXD	16	I	Receive data	If these pins are unused, keep open.
TXD	17	O	Transmit data	
RTS	19	I	Request to send	
CTS	20	O	Clear to send	
DCD	23	O	Data carrier detect	
RI	22	O	Ring indicator	
DTR	21	I	Data terminal ready	
Debug interface				
DBG_TXD	42	O	For debugging and upgrading firmware	If these pins are unused, keep open.
DBG_RXD	41	I		
SIM interface				
SIM_VDD	13	O	Voltage supply for SIM card. Support 1.8V or 3V SIM card	All signals of SIM interface should be protected against ESD with a TVS diode array.
SIM_DATA	11	I/O	SIM data input/output	
SIM_CLK	10	O	SIM clock	
SIM_RST	12	O	SIM reset	
SIM_PRESENCE	44	I	SIM card detection	If it is unused, keep open.
ADC				
ADC	37	I	Input voltage range: 0V ~ 2.8V	If it is unused, keep open.
External reset				
NRESET	15	I	Reset input(Active low)	Recommend connecting a 100nF capacitor.
Pulse width modulation(PWM)				
PWM1	56	O	PWM	If these pins are unused, keep open.
PWM2	55	O	PWM	
RF interface				
RF_ANT	28	I/O	RF antenna connection	Impedence must be controlled to 50Ω.

3.3 Package Dimensions

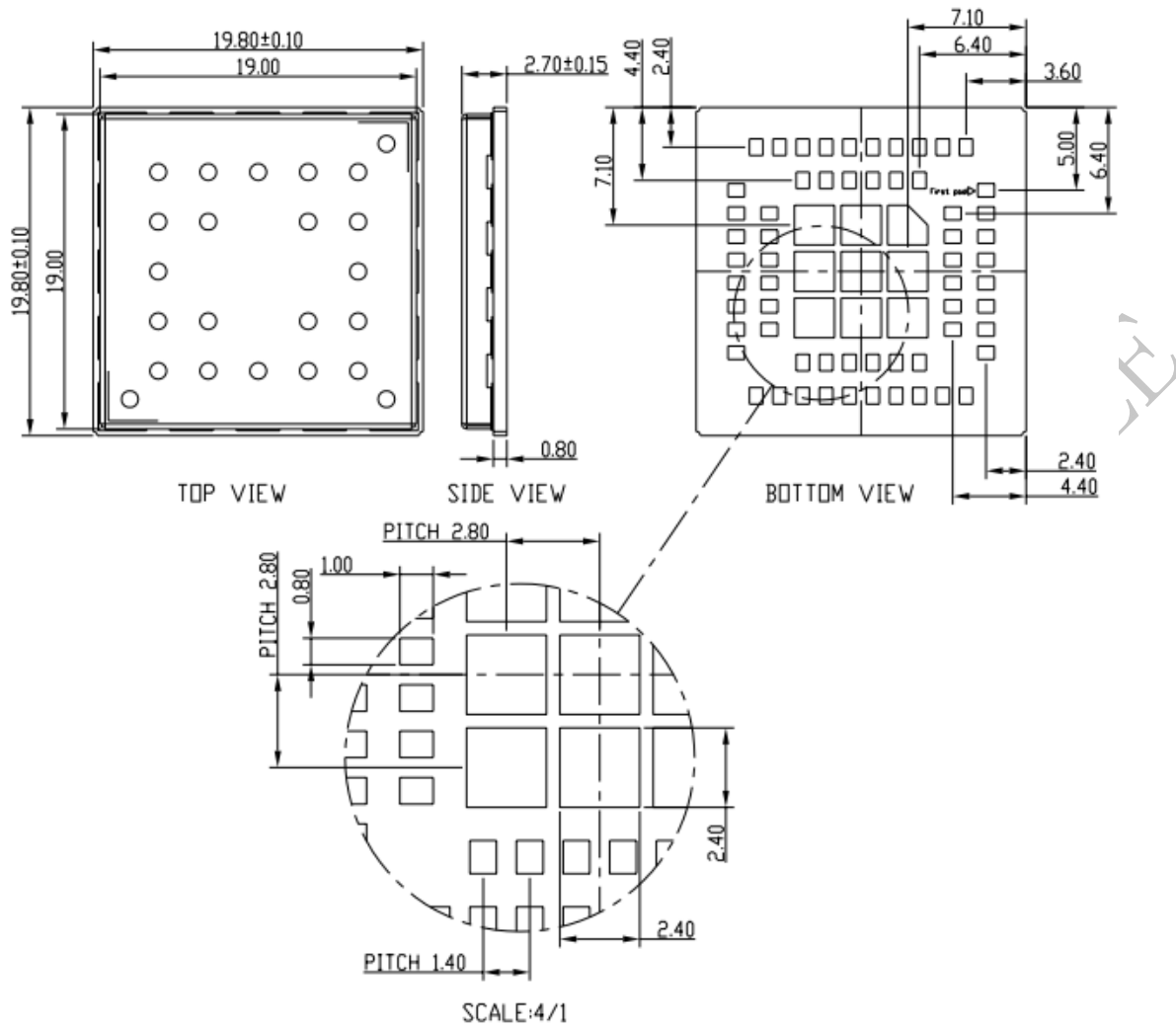
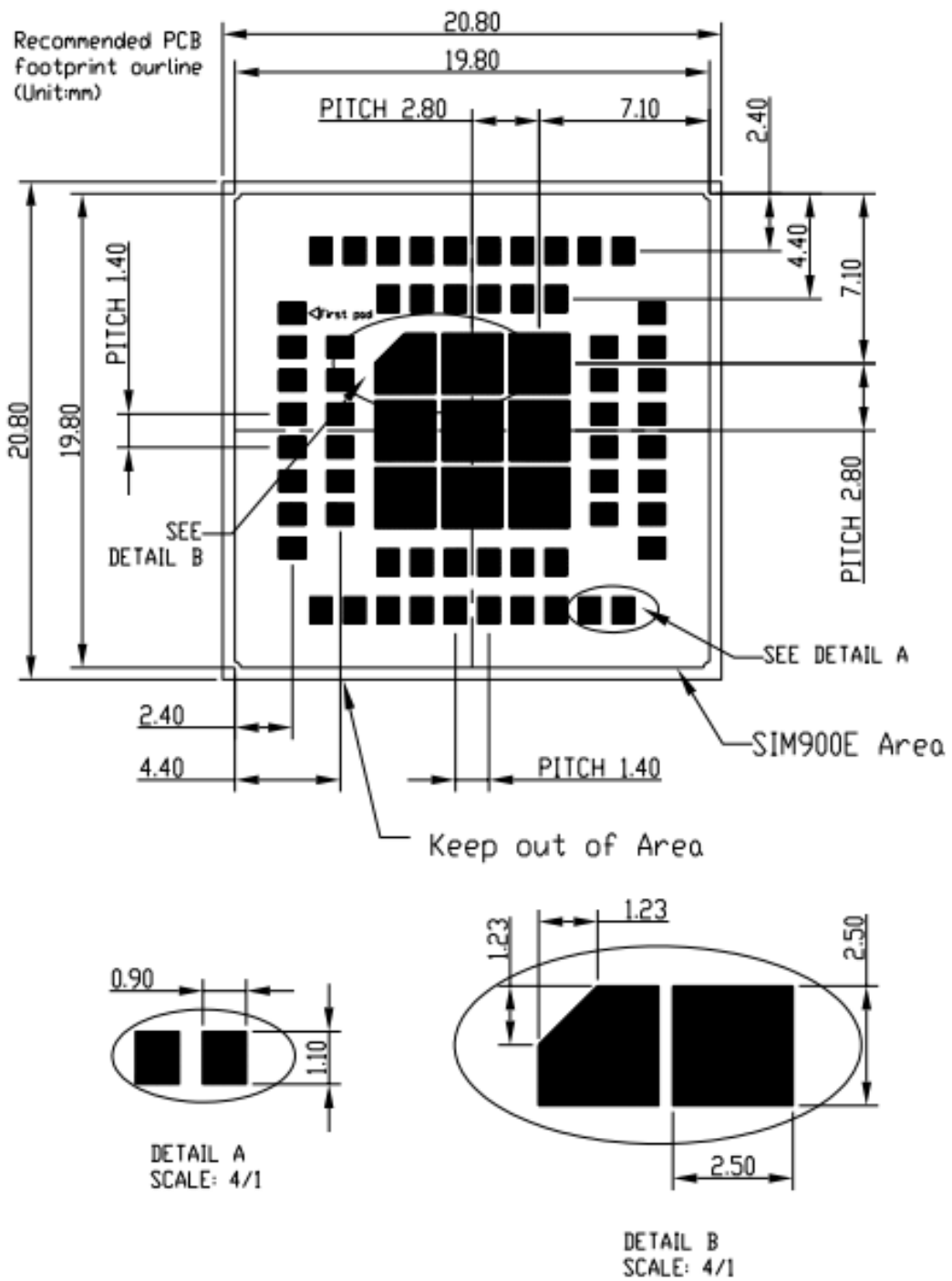

Figure 3: Dimensions of SIM900E (Unit: mm)



UNIT:mm

Figure 4: Recommended PCB footprint outline (Unit: mm)

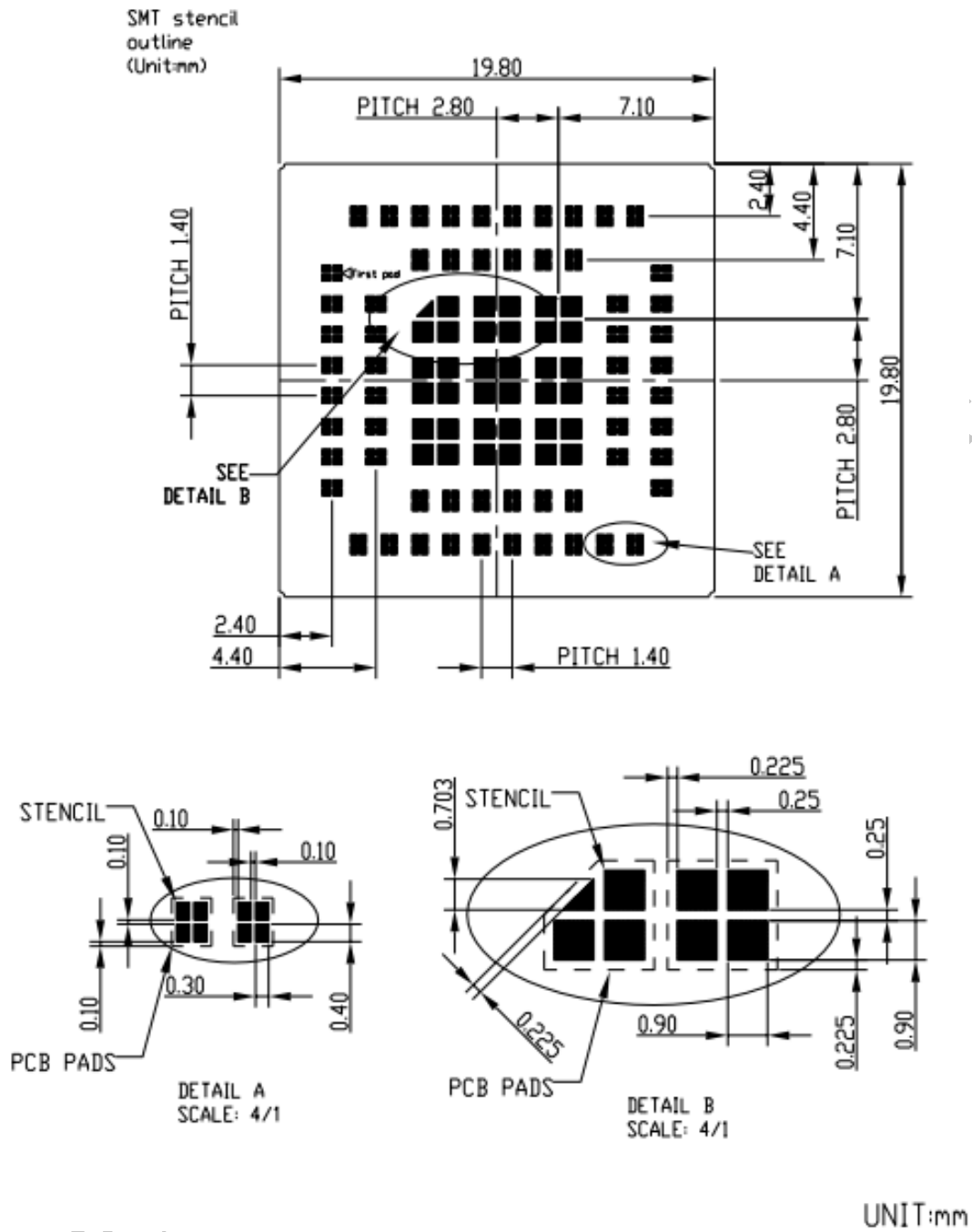

Figure 5: Recommended SMT stencil outline (Unit: mm)

4 Application Interface

4.1 Power Supply

The power supply range of SIM900E is from 3.2V to 4.8V. The transmitting burst will cause voltage drop and the power supply must be able to provide sufficient current up to 2A. For the VBAT input, a bypass capacitor (low ESR) such as a 100 μF is strongly recommended; this capacitor should be placed as close as possible to SIM900E VBAT pins. The following figure is the reference design of +5V input power supply. The designed output for the power supply is 4.1V, thus a linear regulator can be used.

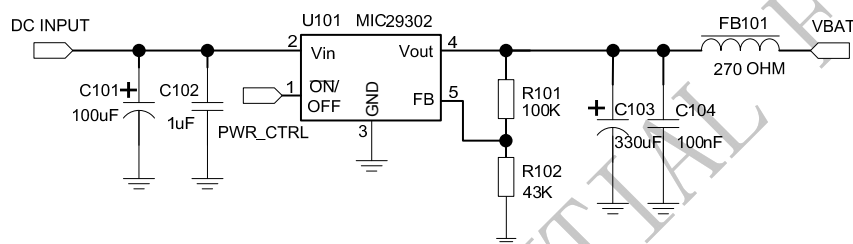

Figure 6: Reference circuit of the LDO power supply

If there is a high drop-out between the input and the desired output (VBAT), a DC-DC power supply will be preferable because of its better efficiency especially with the 2A peak current in burst mode of the module. The following figure is the reference circuit.

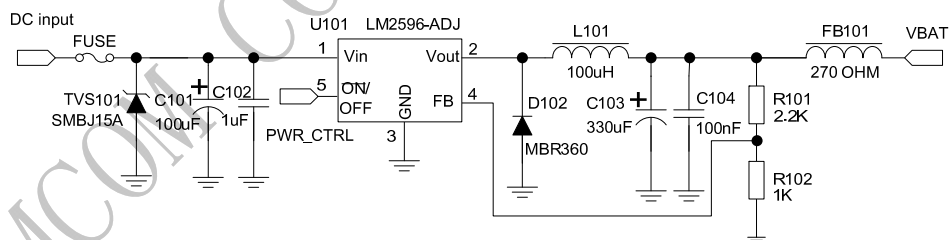

Figure 7: Reference circuit of the DC-DC power supply

The single 3.6V Li-ion cell battery can be connected to SIM900E VBAT pins directly. But the Ni-Cd or Ni-MH battery must be used carefully, since their maximum voltage can rise over the absolute maximum voltage of the module and damage it.

When battery is used, the total impedance between battery and VBAT pins should be less than 150m Ω .

The following figure shows the VBAT voltage drop at the maximum power transmit phase, and the test condition is as following:

$$\text{VBAT}=4.0\text{V,}$$

A VBAT bypass capacitor $C_A=100\mu\text{F}$ tantalum capacitor (ESR=0.7 Ω),

Another VBAT bypass capacitor $C_B=1\mu\text{F}$.

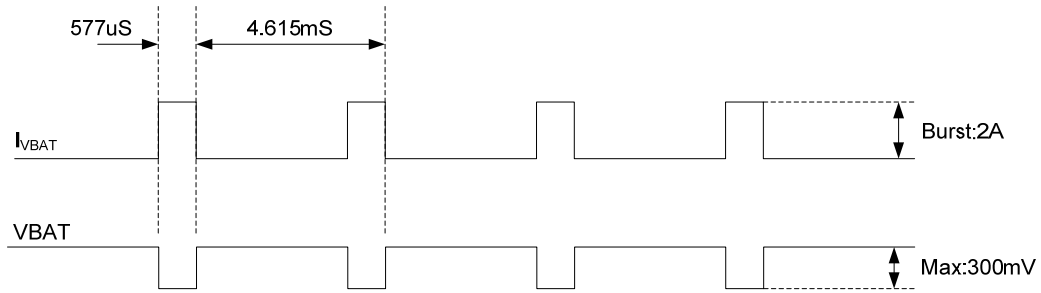

Figure 8: VBAT voltage drop during transmit burst

4.1.1 Minimizing Voltage Drop of VBAT

When designing the power supply in user’s application, pay special attention to power losses. Ensure that the input voltage never drops below 3.1V even when current consumption rises to 2A in the transmit burst. If the power voltage drops below 3.1V, the module may be shut down automatically. The PCB traces from the VBAT pins to the power supply must be wide enough (at least 60mil) to decrease voltage drops in the transmit burst. The power IC and the bypass capacitor should be placed to the module as close as possible.

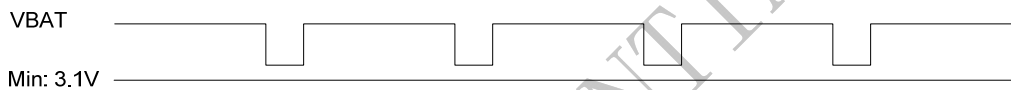

Figure 9: The minimal VBAT voltage requirement at VBAT drop

4.1.2 Monitoring Power Supply

The AT command “AT+CBC” can be used to monitor the VBAT voltage. For detail, please refer to *document [1]*.

4.2 Power on/down Scenarios

4.2.1 Power on SIM900E

User can power on SIM900E by pulling down the PWRKEY pin for at least 1 second and release. This pin is already pulled up to 3V in the module internal, so external pull up is not necessary. Reference circuit is shown as below.

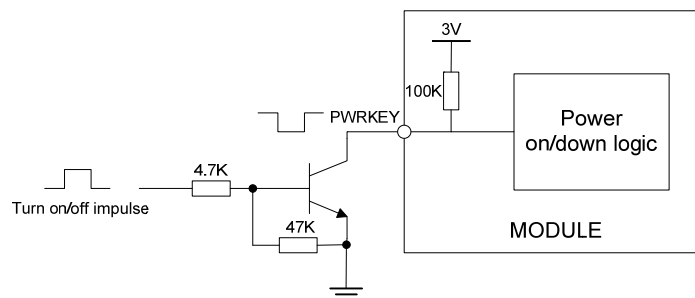

Figure 10: Powered on/down module using transistor

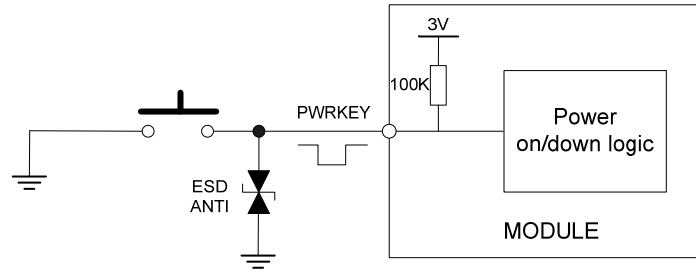

Figure 11: Powered on/down module using button

The power on scenarios is illustrated as following figure.

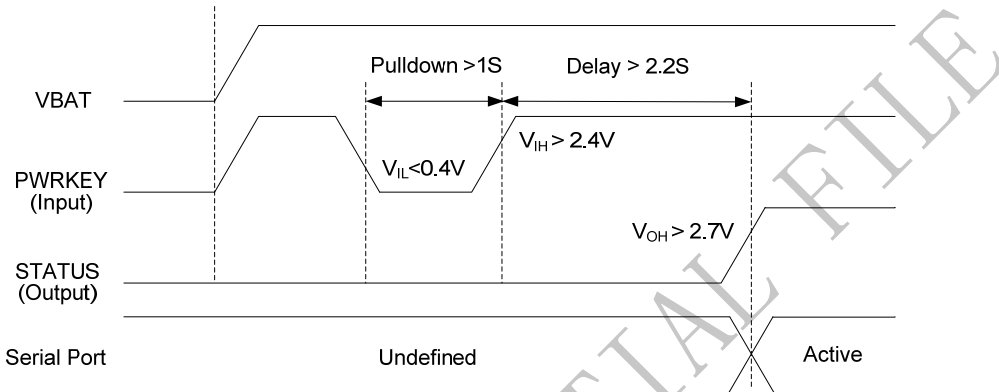

Figure 12: Timing of power on module

When power on procedure is completed, SIM900E will send following URC to indicate that the module is ready to operate at fixed baud rate.

RDY

This URC does not appear when autobauding function is active.

Note: User can use AT command “AT+IPR=x” to set a fixed baud rate and save the configuration to non-volatile flash memory. After the configuration is saved as fixed baud rate, the Code “RDY” should be received from the serial port every time when SIM900E is powered on. For details, please refer to the chapter “AT+IPR” in document [1].

4.2.2 Power down SIM900E

SIM900E will be powered down in the following situations:

- Normal power down procedure: power down SIM900E by the PWRKEY pin.
- Normal power down procedure: power down SIM900E by AT command “AT+CPOWD=1”.
- Abnormal power down: over-voltage or under-voltage automatic power down.
- Abnormal power down: over-temperature or under-temperature automatic power down.

4.2.2.1 Power down SIM900E by the PWRKEY Pin

User can power down SIM900E by pulling down the PWRKEY pin for at least 1 second and release. Please refer to the power on circuit. The power down scenario is illustrated in following figure.

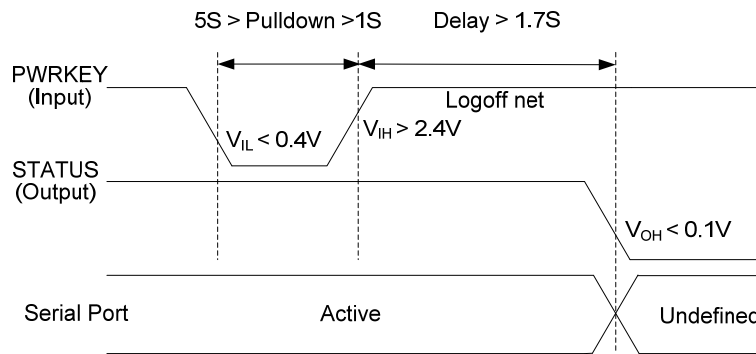

Figure 13: Timing of power down SIM900E by PWRKEY

This procedure makes the module log off from the network and allows the software to enter into a secure state to save data before completely shut down.

Before the completion of the power down procedure, the module will send URC:

NORMAL POWER DOWN

At this moment, AT commands can not be executed any more, and only the RTC is still active. Power down mode can also be indicated by STATUS pin, which is at low level at this time.

4.2.2.2 Power down SIM900E by AT Command

SIM900E can be powered down by AT command “AT+CPOWD=1”. This procedure makes the module log off from the network and allows the software to enter into a secure state to save data before completely shut down.

Before the completion of the power down procedure, the module will send URC:

NORMAL POWER DOWN

At this moment, AT commands can not be executed any more, and only the RTC is still active. Power down mode can also be indicated by STATUS pin, which is at low level at this time.

For detail about the AT command “AT+CPOWD”, please refer to *document [1]*

4.2.2.3 Over-voltage or Under-voltage Power down

The module software monitors the VBAT voltage constantly.

If the voltage $\leq 3.3V$, the following URC will be reported:

UNDER-VOLTAGE WARNING

If the voltage $\geq 4.7V$, the following URC will be reported:

OVER-VOLTAGE WARNING

If the voltage $< 3.2V$, the following URC will be reported, and the module will be automatically powered down.

UNDER-VOLTAGE POWER DOWN

If the voltage $> 4.8V$, the following URC will be reported, and the module will be automatically powered down.

OVER-VOLTAGE POWER DOWN

At this moment, AT commands can not be executed any more, and only the RTC is still active. Power down mode can also be indicated by STATUS pin, which is at low level at this time.

4.2.2.4 Over-temperature or Under-temperature Power down

The module will constantly monitor the temperature of the module, If the temperature > +80°C, the following URC will be reported:

+CMTE: 1

If the temperature < -30°C, the following URC will be reported:

+CMTE:-1

If the temperature > +85°C, the following URC will be reported, and the module will be automatically powered down.

+CMTE: 2

If the temperature < -40°C, the following URC will be reported, and the module will be automatically powered down.

+CMTE:-2

At this moment, AT commands can not be executed any more, and only the RTC is still active. Power down mode can also be indicated by STATUS pin, which is at low level at this time.

The AT command “AT+CMTE” could be used to read the temperature when the module is running. For details please refer to *document [1]*.

4.2.3 Restart SIM900E by PWRKEY Pin

When the module works normally, if the user wants to restart the module, follow the procedure below:

- 1) Power down the module.
- 2) Wait for at least 800mS after STATUS pin changed to low level.
- 3) Power on the module.

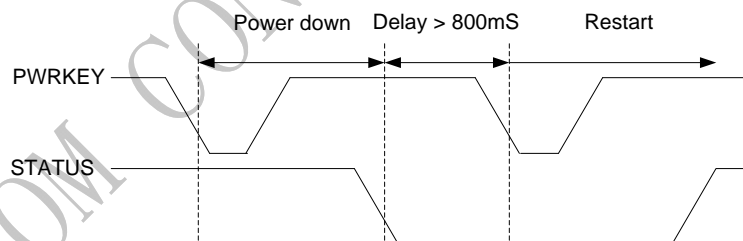

Figure 14: Timing of restart SIM900E

4.3 Power Saving Mode

SIM900E have two sleep modes: sleep mode 1 is enabled by hardware pin DTR; sleep mode 2 is only enabled by serial port regardless of the DTR. In sleep mode, the current of module is very low. The AT command “AT+CFUN=<fun>” can be used to set SIM900E into minimum functionality. When SIM900E is in sleep mode and minimum functionality, the current of module is lowest.

4.3.1 Minimum Functionality Mode

There are three functionality modes, which could be set by the AT command “AT+CFUN=<fun>”. The command provides the choice of the functionality levels <fun>=0,1,4.

- 0: minimum functionality.
- 1: full functionality (default).
- 4: flight mode (disable RF function).

Minimum functionality mode minimizes the current consumption to the lowest level. If SIM900E is set to minimum functionality by “AT+CFUN=0”, the RF function and SIM card function will be disabled. In this case, the serial port is still accessible, but all AT commands correlative with RF function and SIM card function will not be accessible.

For detailed information about the AT Command “AT+CFUN=<fun>”, please refer to *document [1]*.

Table 5: The Current consumption of Minimum Functionality Mode

<fun>	Current consumption(uA) (sleep mode)
0	651
1	1000
4	715

4.3.2 Sleep Mode 1 (AT+CSCLK=1)

User can control SIM900E module to enter or exit the sleep mode 1 (AT+CSCLK=1) by DTR signal. When DTR is in high level and without interrupt (on air and hardware such as GPIO interrupt or data in serial port), SIM900E will enter sleep mode 1 automatically. In this mode, SIM900E can still receive paging or SMS from network but the serial port is not accessible.

Note: For SIM900E, it requests to set AT command “AT+CSCLK=1” and ensure DTR at high level to enable the sleep mode 1; the default value is 0, which can not make the module to enter sleep mode. For more details please refer to document [1].

4.3.3 Wake Up SIM900E from Sleep Mode 1 (AT+CSCLK=1)

When SIM900E is in sleep mode 1 (AT+CSCLK=1), the following methods can wake up the module:

- Pull down DTR pin.
The serial port will be active after DTR pin is pulled to low level for about 50ms.
- Receive a voice or data call from network.
- Receive a SMS from network.

Note: If AT+CSCLK=1, it is requested to pull down DTR pin to enable the sleep mode, else can not make the module to enter sleep mode.

4.3.4 Sleep Mode 2 (AT+CSCLK=2)

In this mode, SIM900E will continuously monitor the serial port data signal. When there is no data transfer over 5 seconds on the RXD signal and there is no on air and hardware interrupts (such as GPIO interrupt), SIM900E will enter sleep mode 2 automatically. In this mode, SIM900E can still receive paging or SMS from network but the serial port is not accessible.

Note: For SIM900E, It is requested to set AT command “AT+CSCLK=2” to enable the sleep mode 2; the default value is 0, which

can not make the module to enter sleep mode. For more details please refer to document [1].

4.3.5 Wake Up SIM900E from Sleep Mode 2 (AT+CSCLK=2)

When SIM900E is in sleep mode 2 (AT+CSCLK=2), the following methods can wake up the module:

- Send data to SIM900E via main serial port. *
- Receive a voice or data call from network.
- Receive a SMS from network.

* Note: The first byte of the user's data will not be recognized.

4.4 RTC Backup

Current input for RTC when the VBAT is not supplied for the system. Current output for backup battery when the VBAT power supply is in present and the backup battery is in low voltage state. The RTC power supply of module can be provided by an external capacitor or a battery (non-chargeable or rechargeable) through the VRTC. The following figures show various reference circuits for RTC back up.

- External capacitor backup

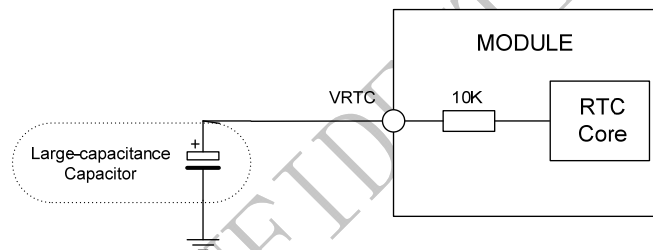

Figure 15: RTC supply from capacitor

- Non-chargeable battery backup

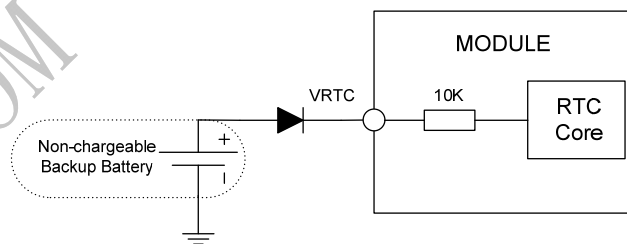

Figure 16: RTC supply from non-chargeable battery

- Rechargeable battery backup

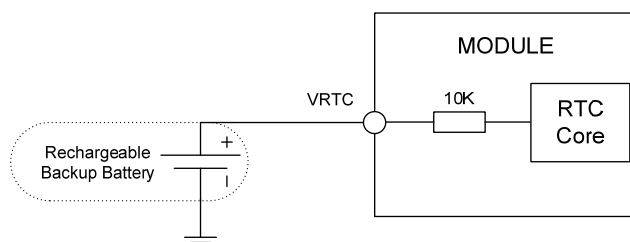

Figure 17: RTC supply from rechargeable battery

Coin-type rechargeable battery is recommended, such as XH414H-IV01E form Seiko can be used. Typical charge-discharge curves for this battery are shown in the following figure.

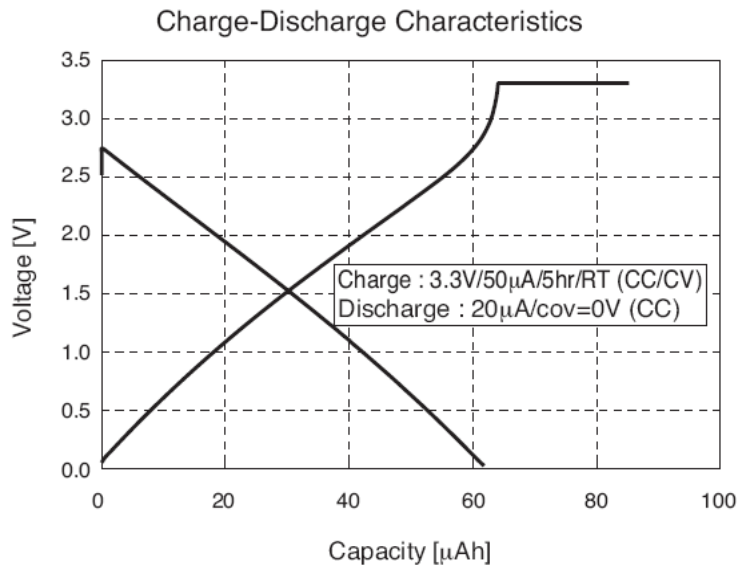

Figure 18: Seiko XH414H-IV01E Charge-Discharge Characteristic

4.5 Serial Interfaces

SIM900E provides two unbalanced asynchronous serial ports. One is the serial port and the other is the debug port. The module is designed as a DCE (Data Communication Equipment). The following figure shows the connection between module and client (DTE).

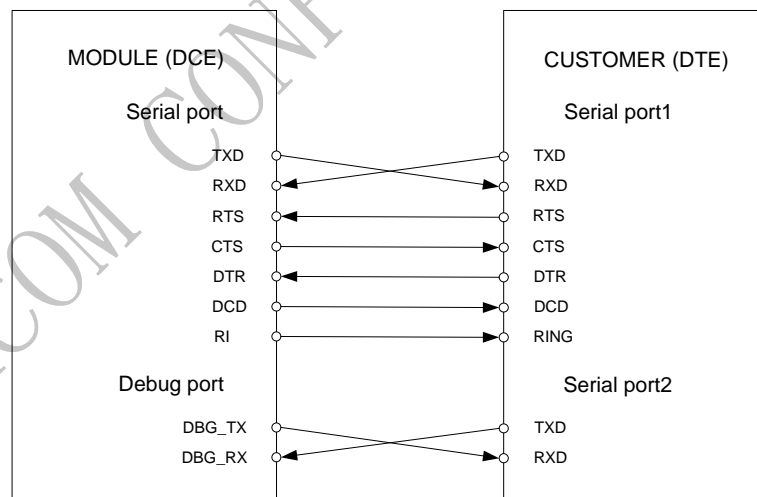

Figure 19: Connection of the serial interfaces

If only RXD and TXD are used in user’s application, other serial pins should be kept open. Please refer to following figure.

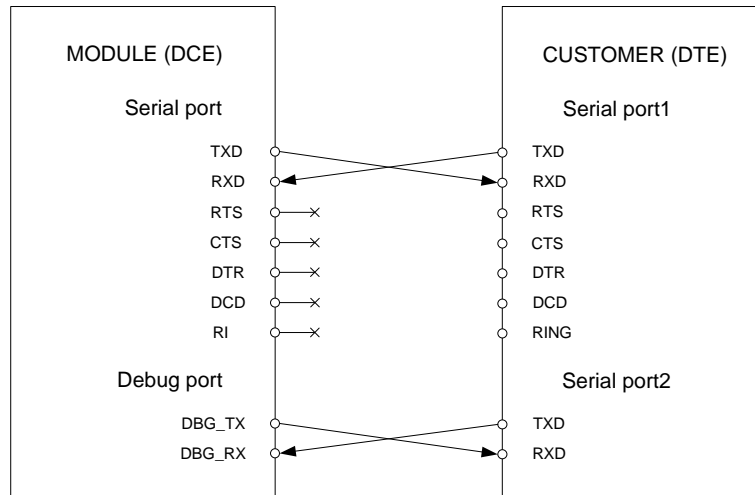

Figure 20: Connection of RXD and TXD only

4.5.1 Function of Serial Port and Debug Port

Serial port:

- Full modem device.
- Contains data lines TXD and RXD, hardware flow control lines RTS and CTS, status lines DTR, DCD and RI.
- Serial port can be used for CSD FAX, GPRS service and AT communication. It can also be used for multiplexing function. For details about multiplexing function, please refer to *document [3]*.
- Serial port supports the following baud rates:
1200, 2400, 4800, 9600, 19200, 38400, 57600 and 115200bps
- Autobauding only supports the following baud rates:
1200, 2400, 4800, 9600, 19200, 38400 and 57600bps
- The default setting is autobauding.

Autobauding allows SIM900E to automatically detect the baud rate of the host device. Pay more attention to the following requirements:

- **Synchronization between DTE and DCE:**

When DCE powers on with autobauding enabled, user must firstly send character “A” to synchronize the baud rate. It is recommended to send “AT” until DTE receives the “OK” response, which means DTE and DCE are correctly synchronized. For more information please refer to the AT command “AT+IPR”.

- **Restrictions of autobauding operation:**

The DTE serial port must be set at 8 data bits, no parity and 1 stop bit.

The URC such as "RDY", "+CFUN: 1" and "+CPIN: READY" will not be reported.

Note: User can use AT command “AT+IPR=x” to set a fixed baud rate and the setting will be saved to non-volatile flash memory automatically. After the configuration is set as fixed baud rate, the URC such as "RDY", "+CFUN: 1" and "+CPIN: READY" will be reported when SIM900E is powered on.

Debug port:

- Used for debugging and upgrading firmware.
- Debug port supports the baud rate of 115200bps.

4.5.2 Software Upgrade and Debug

Refer to the following figure for debugging and upgrading software.

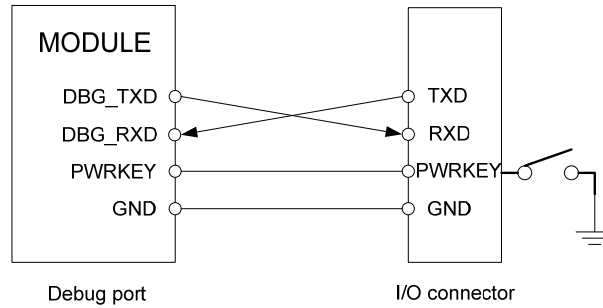

Figure 21: Connection for software upgrading and debugging

The serial port and the debug port support the CMOS level. If user connects the module to the computer, the level shifter should be added between the DCE and DTE.

For details about software upgrading, please refer to *document [4]*.

4.6 Audio Interfaces

SIM900E provides one analog input, AIN, which could be used for electret microphone. The module also provides one analog output, AOUT. The output can directly drive 32Ω receiver.

AT command “AT+CMIC” is used to adjust the input gain level of microphone. AT command “AT+SIDET” is used to set the side-tone level. In addition, AT command “AT+CLVL” is used to adjust the output gain level. For more details, please refer to *document [1]* and *document [5]*.

In order to improve audio performance, the following reference circuits are recommended. The audio signals have to be layout according to differential signal layout rules as shown in following figures. If user needs to use an amplifier circuit for audio, National Semiconductor Company’s LM4890 is recommended.

4.6.1 Speaker Interface Configuration

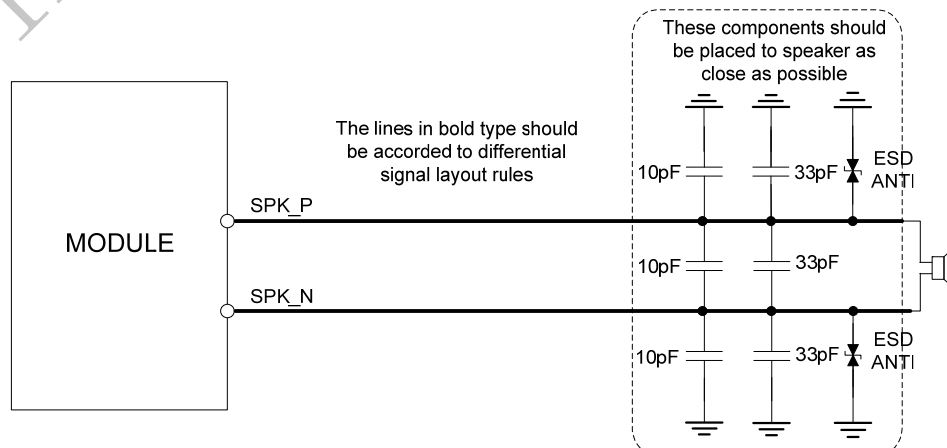

Figure 22: Speaker reference circuit

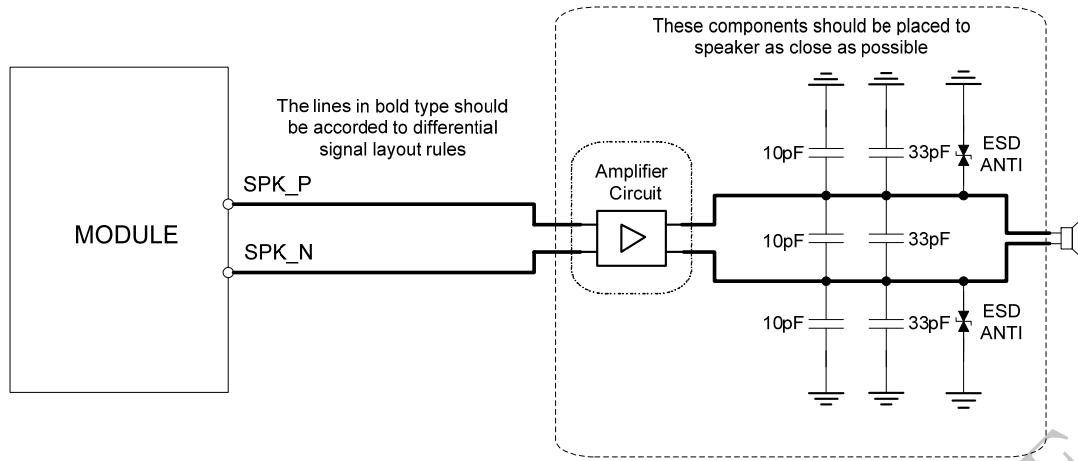

Figure 23: Speaker with amplifier reference circuit

4.6.2 Microphone Interfaces Configuration

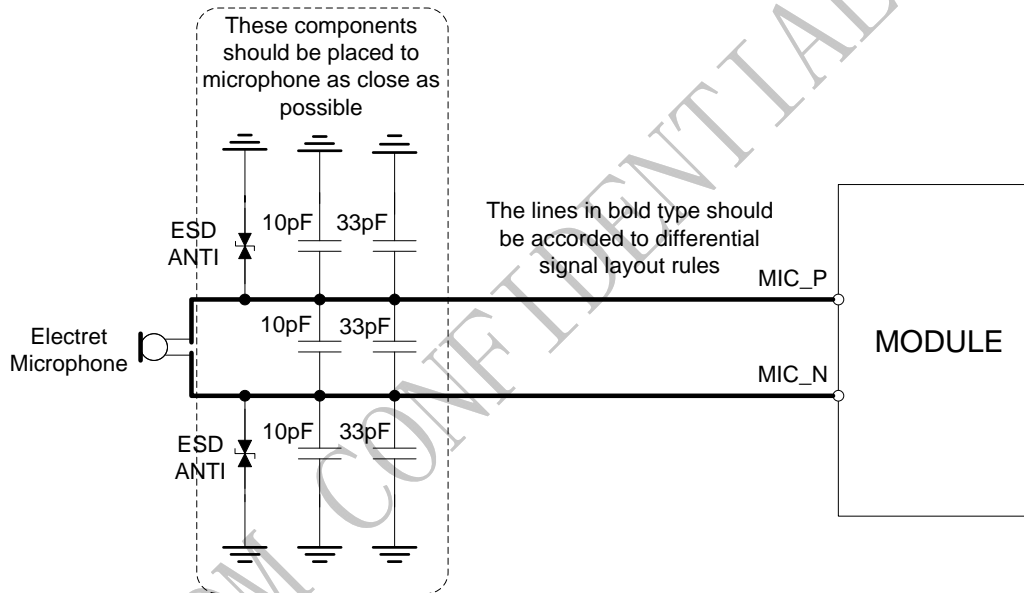

Figure 24 : Microphone reference circuit

Microphone input also could be used to LINE-IN input. For details, please refer to *document [6]*.

4.6.3 Earphone Interface Configuration

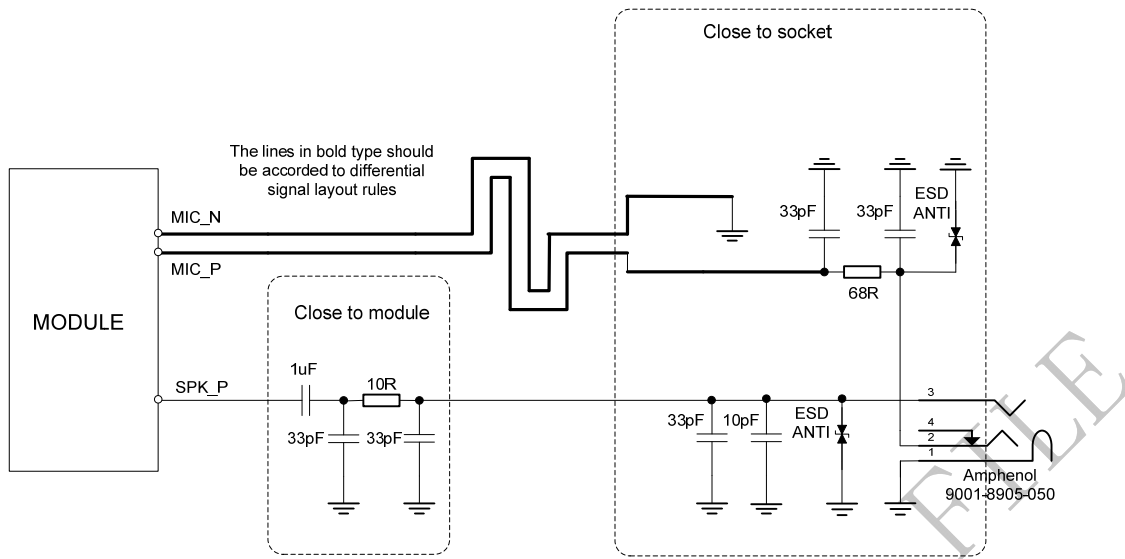

Figure 25: Earphone reference circuit

4.6.4 Audio Electronic Characteristics

Table 6: Microphone Input Characteristics

Parameter	Min	Typ	Max	Unit
Working Voltage	1.2	1.5	2.0	V
Working Current	200		500	uA
External Microphone Load Resistance	1.2	2.2		kΩ
Internal biasing DC Characteristics			2.5	V
Differential input voltage	THD <1% at F=1KHz; pre-amp gain = 20 dB; PGA gain = 14 dB		15.9	mVrms
	THD <5% at F=1KHz; pre-amp gain = 0 dB; PGA gain = 0 dB		740	mVrms

Table 7: Audio Output Characteristics

Parameter	Conditions	Min	Typ	Max	Unit
Normal Output(SPK)	RL=32Ω THD=0.1%	-	91	-	mW
	RL=32Ω THD=1%	-	96	-	mW
	Output swing Voltage (single ended)			1.1	Vpp
	Output swing Voltage (differential)			2.2	Vpp

4.7 SIM Card Interface

4.7.1 SIM Card Application

The SIM interface complies with the GSM Phase 1 specification and the new GSM Phase 2+ specification for FAST 64 kbps SIM card. Both 1.8V and 3.0V SIM card are supported. The SIM interface is powered from an internal regulator in the module.

It is recommended to use an ESD protection component such as ST (www.st.com) ESDA6V1W5 or ON SEMI (www.onsemi.com) SMF05C. The pull up resistor (15KΩ) on the SIM_DATA line is already added in the module internal. Note that the SIM peripheral circuit should be close to the SIM card socket. The reference circuit of the 8-pin SIM card holder is illustrated in the following figure.

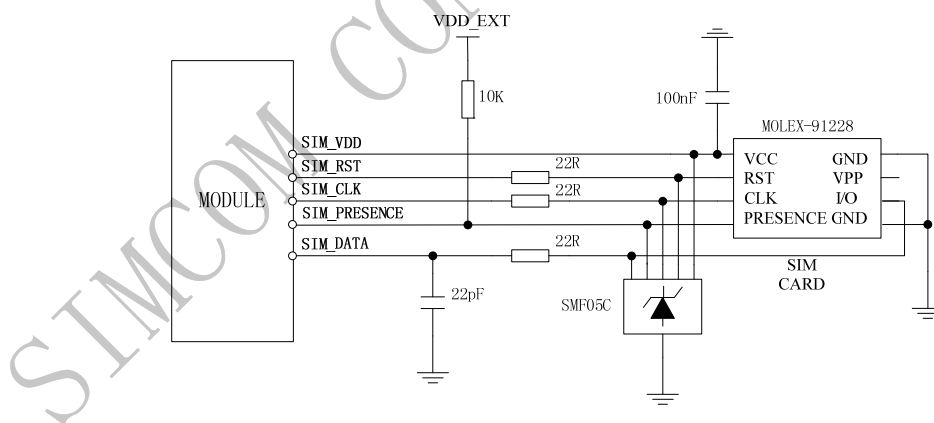
Figure 26: Reference circuit of the 8-pin SIM card holder

The SIM_PRESENCE pin is used for detection of the SIM card hot plug in. User can select the 8-pin SIM card holder to implement SIM card detection function. AT command “AT+CSDT” is used to enable or disable SIM card detection function. For details of this AT command, please refer to *document [1]*.

If the SIM card detection function is not used, user can keep the SIM_PRESENCE pin open. The reference circuit of 6-pin SIM card holder is illustrated in the following figure.

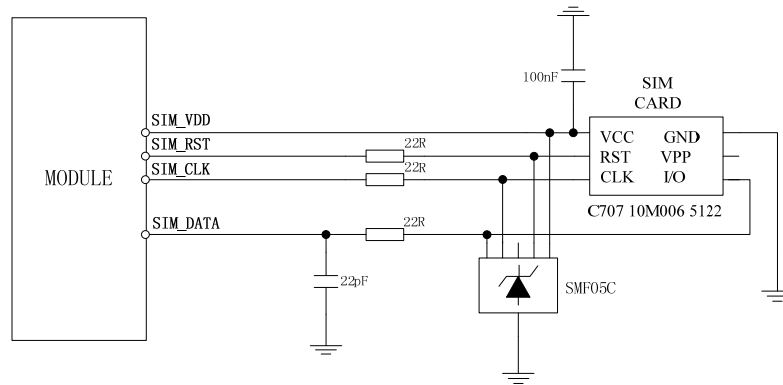

Figure 27: Reference circuit of the 6-pin SIM card holder

4.7.2 Design Considerations for SIM Card Holder

For 6-pin SIM card holder, SIMCom recommends to use Amphenol C707 10M006 5122 .User can visit <http://www.amphenol.com> for more information about the holder.

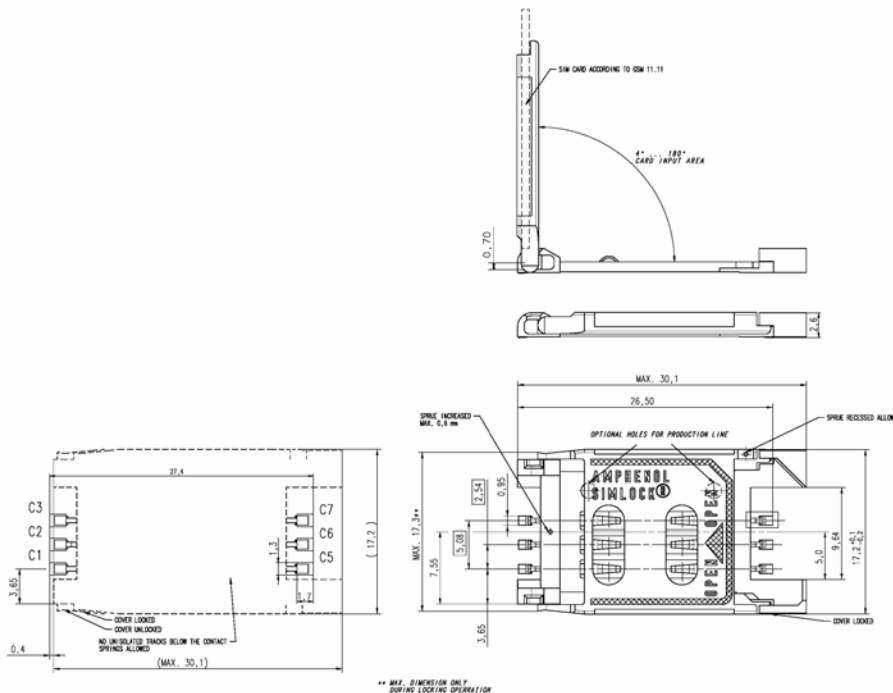

Figure 28: Amphenol C707 10M006 5122 SIM card holder

Table 8: Pin description (Amphenol SIM card holder)

Pin name	Signal	Description
C1	SIM_VDD	SIM card power supply
C2	SIM_RST	SIM card reset
C3	SIM_CLK	SIM card clock
C5	GND	Connect to GND
C6	VPP	Not connect
C7	SIM_DATA	SIM card data I/O

For 8 pins SIM card holder, SIMCom recommends to use Molex 91228. User can visit <http://www.molex.com> for more information about the holder.

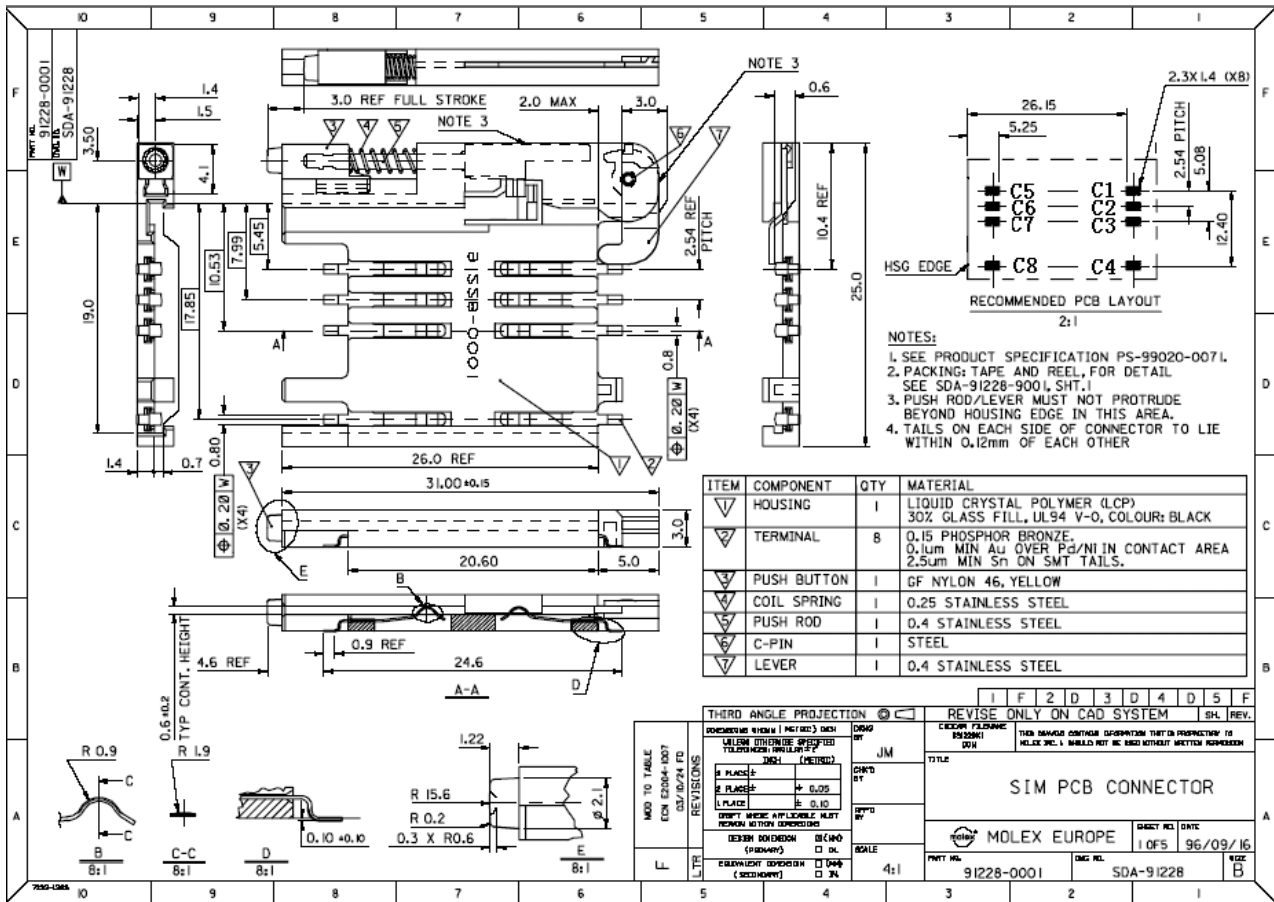

Figure 29: Molex 91228 SIM card holder

Table 9: Pin description (Molex SIM card holder)

Pin name	Signal	Description
C1	SIM_VDD	SIM card power supply
C2	SIM_RST	SIM card reset
C3	SIM_CLK	SIM card clock
C4	GND	Connect to GND
C5	GND	Connect to GND
C6	VPP	Not connect
C7	SIM_DATA	SIM card data I/O
C8	SIM_PRESENCE	Detect SIM card presence

4.8 LCD Display/SPI Interface

SIM900E provides a serial LCD display interface. It could also be used as SPI interface in the embedded AT application. For details about embedded AT application, please refer to *document [7]*.

Note: This function is not supported in the standard firmware. If user wants this function, the firmware must be customized. Please contact SIMCom for more details.

4.9 Keypad Interface

The keypad interface consists of 4 keypad column outputs and 5 keypad row inputs. The basic configuration is 4 keypad columns and 5 keypad rows, total 20 keys.

Table 10: Pin definition of the keypad interface

Pin name	Pin number	Default function	Second function	Default state
GPIO1/ KBR4	46	GPIO1	Keypad matrix column	Input, Pull down
GPIO2/ KBR3	52	GPIO2		Input, Pull down
GPIO3/ KBR2	53	GPIO3		Input, Pull down
GPIO4/ KBR1	51	GPIO4		Input, Pull down
GPIO5/ KBR0	50	GPIO5		Input, Pull down
GPIO6/ KBC4	48	GPIO6	Keypad matrix row	Input, Pull down
GPIO7/ KBC3	49	GPIO7		Input, Pull down
GPIO8/ KBC2	45	GPIO8		Input, Pull down
GPIO9/ KBC1	47	GPIO9		Input, Pull down

The keypad interface allows a direct external matrix connection. A typical recommended circuit of the keypad is shown in the following figure.

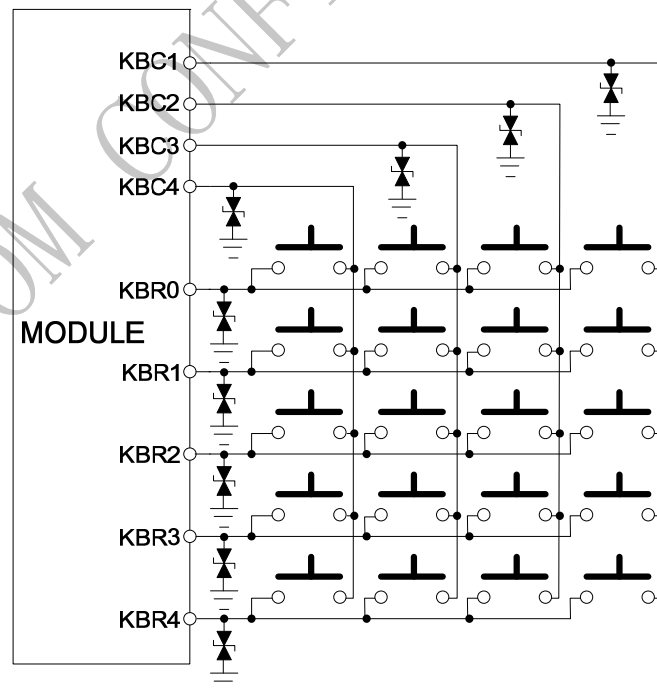

Figure 30: Reference circuit of the keypad interface

Note: This function is not supported in the standard firmware. If user wants this function, the firmware must be customized. Please contact SIMCom for more details.

4.10 ADC

SIM900E provides an auxiliary ADC, which can be used to measure the voltage. User can use AT command “AT+CADC” to read the voltage value. For details of this AT command, please refer to *document [1]*.

Table 11: ADC specification

Parameter	Min	Typ	Max	Unit
Voltage range	0	-	2.8	V
ADC Resolution	-	10	-	bits
Sampling rate	-	-	200K	Hz

4.11 RI Behaviors

Table 12: RI Behaviors

State	RI response
Standby	High
Voice call	The pin is changed to low. When any of the following events occur, the pin will be changed to high: (1) Establish the call (2) Hang up the call
Data call	The pin is changed to low. When any of the following events occur, the pin will be changed to high: (1) Establish the call (2) Hang up the call
SMS	The pin is changed to low, and kept low for 120ms when a SMS is received. Then it is changed to high.
URC	The pin is changed to low, and kept low for 120ms when some URCs are reported. Then it is changed to high. For more details, please refer to <i>document [8]</i> .

The behavior of the RI pin is shown in the following figure when the module is used as a receiver.

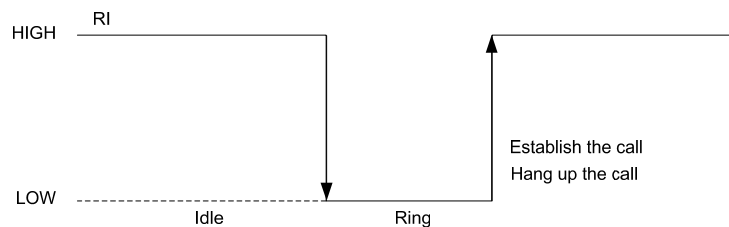

Figure 31: RI behaviour of voice calling as a receiver

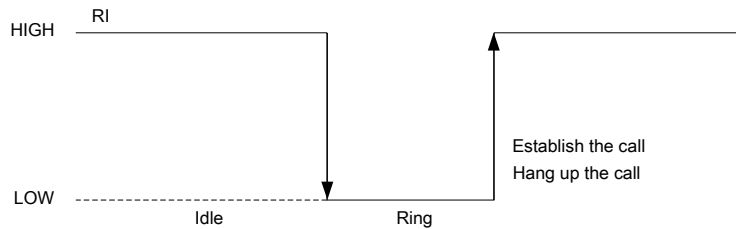

Figure 32: RI behaviour of data calling as a receiver

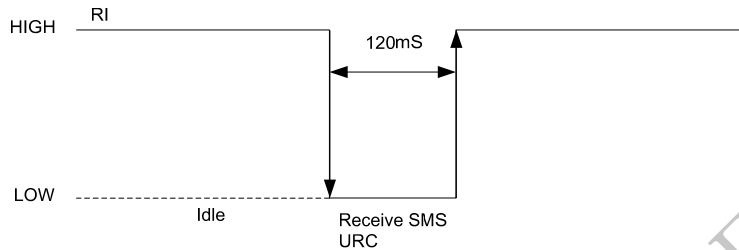

Figure 33: RI behaviour of URC or receive SMS

However, if the module is used as caller, the RI will remain high. Please refer to the following figure.



Figure 34: RI behaviour as a caller

4.12 Network Status Indication

The NETLIGHT pin can be used to drive a network status indication LED. The status of this pin is listed in following table:

Table 13: Status of the NETLIGHT pin

Status	SIM900E behavior
Off	SIM900E is not running
64ms On/ 800ms Off	SIM900E not registered the network
64ms On/ 3000ms Off	SIM900E registered to the network
64ms On/ 300ms Off	GPRS communication is established

A reference circuit is recommended in the following figure:

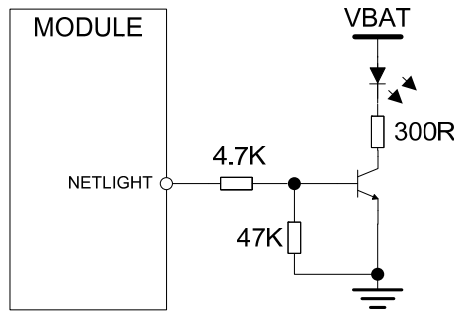

Figure 35: Reference circuit of NETLIGHT

4.13 General Purpose Input/Output (GPIO)

SIM900E provides up to 12 GPIO pins. The output voltage level of the GPIO can be set by the AT command “AT+ SGPIO”. The input voltage level of the GPIO can also be read by the AT command “AT+ SGPIO”. For more details, please refer to *document [1]*.

Table 14: Pin definition of the GPIO interface

Pin name	Pin number	Default function	Second function	Default state
GPIO1/ KBR4	46	GPIO1	KBR4	input, pull down
GPIO2/ KBR3	52	GPIO2	KBR3	input, pull down
GPIO3/ KBR2	53	GPIO3	KBR2	input, pull down
GPIO4/ KBR1	51	GPIO4	KBR1	input, pull down
GPIO5/ KBR0	50	GPIO5	KBR0	input, pull down
GPIO6/ KBC4	48	GPIO6	KBC4	input, pull down
GPIO7/ KBC3	49	GPIO7	KBC3	input, pull down
GPIO8/ KBC2	45	GPIO8	KBC2	input, pull down
GPIO9/ KBC1	47	GPIO9	KBC1	input, pull down
GPIO10	54	GPIO10		input, pull up
GPIO11	24	GPIO11		input, pull down
GPIO12	38	GPIO12		input, pull down

4.14 External Reset

The external NRESET pin is used to reset the module. This function is used as an emergency reset only when AT command “AT+CPOWD=1” and the PWRKEY pin have no effect. The NRESET pin could be pulled down to reset the module. The reset timing is illustrated in the following figure.

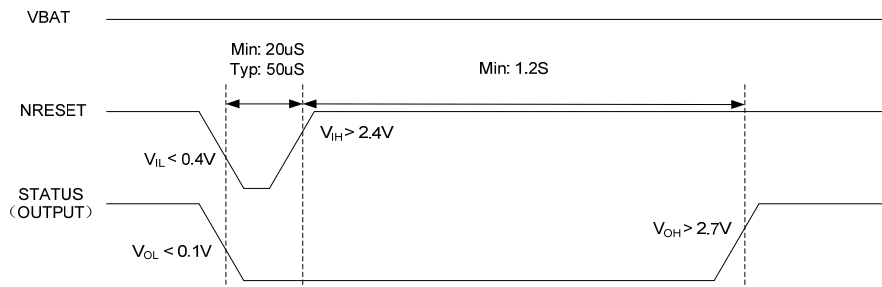

Figure 36: Reset timing

This pin is already pulled up in the module, so the external pull-up resistor is not necessary. A 100nF capacitor close to the NRESET pin is strongly recommended. A reference circuit is shown in the following figure.

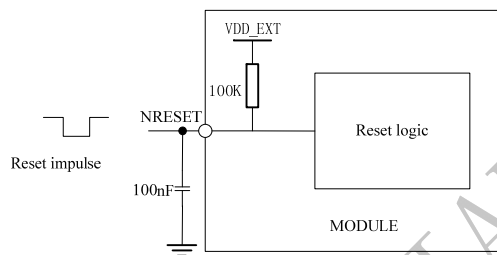

Figure 37: Reset reference design circuit

NOTE: It is recommended to cut off the VBAT power supply directly instead of using external reset pin when SIM900E can not respond to the AT command “AT+CPOWD=1” and PWRKEY pin.

4.15 PWM

SIM900E provides two PWMs. PWM2 can be used to drive a vibrator, and a backlight LED for display or keyboard.

PWM2 output frequency varies from 25.6KHz to 3.25MHz. Two 7-bit unsigned binary parameters are used for the output period and for the duty cycle.

PWM1 is intend for controlling a buzzer.

Features of PWM1:

- 10-bit resolution for buzzer tone frequency generation from 200 Hz to 5 kHz
- Tone frequency error < 1 % for all standard piano notes from 200 Hz to 5 kHz
- Tone level control from 0 dB down to -24 dB in +4 dB steps
- Audio mute

PWM1 outputs a square wave at the desired tone frequency. The tone frequencies are programmable from 200 Hz to 5 kHz and can be re-programmed on-the-fly to generate monophonic audio ring tones or alert tones. The tone level can be adjusted over a 24 dB range in 4 dB steps, or it can be muted.

The AT command “AT + SPWM” is used to set the output period and duty cycle of the PWMs. For details, please refer to *document [1]*.

4.16 I²C Bus

The SIM900E provides an I²C interface which is only used in the embedded AT application.

Note: This function is not supported in the standard firmware. If user wants this function, the firmware must be customized. Please contact SIMCom for more details.

4.17 Antenna Interface

SIM900E provides a RF antenna interface. The customer's antenna should be located in the customer's main board and connected to the module's antenna pad through microstrip line or other type RF traces which impedance must be controlled to 50Ω. To facilitate the antenna tuning and certification test, a RF connector and an antenna matching circuit should be added. The following figure is the recommended circuit.

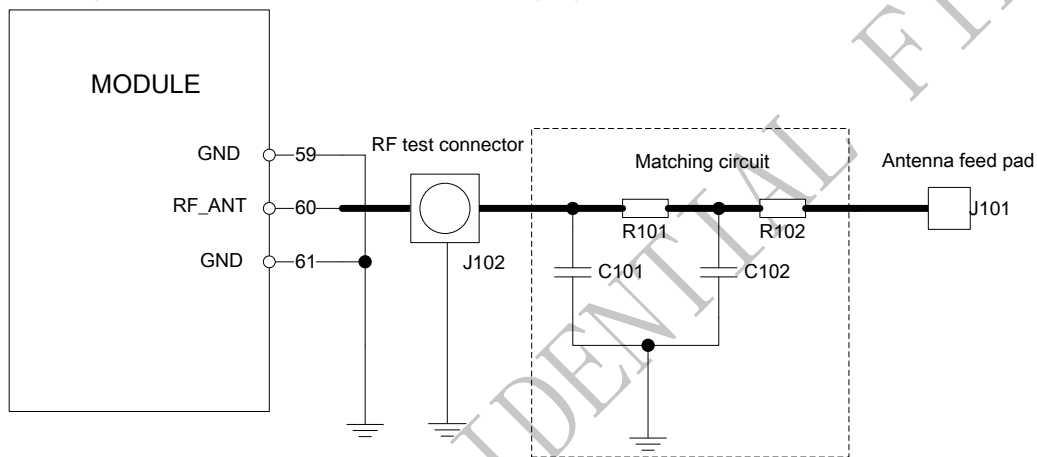

Figure 38: Antenna matching circuit

In this figure, the components R101, R102, C101 and C102 are used for antenna matching, the components' values only can be got after the antenna tuning. Usually, matching components' values are provided by antenna vendor. The default values of R101 and R102 are 0Ω, and reserve the places of C101 and C102 without soldering.

The RF connector in above figure is used for conducted RF performance test, and should be placed as close as possible to the module's RF_ANT pin. The traces in bold type in above figure should be treated as 50Ω impedance controlled line in PCB layout. For details about radio frequency trace layout, please refer to *document [9]*.

5 Electrical, Reliability and Radio Characteristics

5.1 Absolute Maximum Ratings

The absolute maximum ratings stated in following table are stress ratings under non-operating conditions. Stresses beyond any of these limits will cause permanent damage to SIM900E.

Table 15: Absolute maximum ratings

Symbol	Parameter	Min	Typ	Max	Unit
V _{BAT}	Power supply voltage	-	-	5.5	V
V _I *	Input voltage	-0.3	-	3.1	V
I _I *	Input current	-	-	10	mA
I _O *	Output current	-	-	10	mA

* These parameters are for digital interface pins, such as keypad, GPIO, I²C, UART, LCD, PWMs and DEBUG.

5.2 Recommended Operating Conditions

Table 16: Recommended operating conditions

Symbol	Parameter	Min	Typ	Max	Unit
V _{BAT}	Power supply voltage	3.2	4.0	4.8	V
T _{OPER}	Operating temperature	-40	+25	+85	°C
T _{STG}	Storage temperature	-45		+90	°C

5.3 Digital Interface Characteristics

Table 17: Digital interface characteristics

Symbol	Parameter	Min	Typ	Max	Unit
I _{IH}	High-level input current	-10	-	10	uA
I _{IL}	Low-level input current	-10	-	10	uA
V _{IH}	High-level input voltage	2.4	-	-	V
V _{IL}	Low-level input voltage	-	-	0.4	V
V _{OH}	High-level output voltage	2.7	-	-	V
V _{OL}	Low-level output voltage	-	-	0.1	V

* These parameters are for digital interface pins, such as keypad, GPIO, I²C, UART, LCD, PWMs and DEBUG.

5.4 SIM Card Interface Characteristics

Table 18: SIM card interface characteristics

Symbol	Parameter	Min	Typ	Max	Unit
I _{IH}	High-level input current	-10	-	10	uA
I _{IL}	Low-level input current	-10	-	10	uA
V _{IH}	High-level input voltage	1.4	-	-	V
		2.4	-	-	V
V _{IL}	Low-level input voltage	-	-	0.4	V
		-	-	2.4	V
V _{OH}	High-level output voltage	1.7	-	-	V
		2.7	-	-	V
V _{OL}	Low-level output voltage	-	-	0.1	V
		-	-	0.1	V

5.5 VDD_EXT Characteristics

Table 19: VDD_EXT characteristics

Symbol	Parameter	Min	Typ	Max	Unit
V _O	Output voltage	2.70	2.80	2.95	V
I _O	Output current	-	-	10	mA

5.6 SIM_VDD Characteristics

Table 20: SIM_VDD characteristics

Symbol	Parameter	Min	Typ	Max	Unit
V _O	Output voltage	2.75	2.9	3.00	V
		1.65	1.80	1.95	
I _O	Output current	-	-	10	mA

5.7 VRTC Characteristics

Table 21: VRTC characteristics

Symbol	Parameter	Min	Typ	Max	Unit
V _{RTC-IN}	VRTC input voltage	2.00	3.00	3.15	V
I _{RTC-IN}	VRTC input current	-	2	-	uA
V _{RTC-OUT}	VRTC output voltage	-	3.00	-	V
I _{RTC-OUT}	VRTC output current	-	10	-	uA

5.8 Current Consumption (VBAT = 3.8V)

Table 22: Current consumption*

Symbol	Parameter	Conditions	Value	Unit		
I _{VRTC}	VRTC current	VBAT disconnects. Backup battery is 3 V	2	uA		
I _{VBAT}	VBAT current	Power down mode	30	uA		
		Sleep mode	BS-PA-MFRMS=9	1.0	mA	
			BS-PA-MFRMS=5	1.2		
			BS-PA-MFRMS=2	1.5		
		Idle mode	GSM 850	22	mA	
			EGSM 900			
			DCS 1800			
			PCS 1900			
		Voice call	GSM 850 EGSM 900	PCL=5	240	mA
				PCL=12	108	
				PCL=19	81	
			DCS 1800 PCS 1900	PCL=0	176	
				PCL=7	94	
				PCL=15	76	
		Data mode GPRS(1Rx,1Tx)	GSM 850 EGSM 900	PCL=5	240	mA
				PCL=12	110	
				PCL=19	83	
			DCS 1800 PCS 1900	PCL=0	170	mA
				PCL=7	95	
				PCL=15	80	
		Data mode GPRS(4Rx,1Tx)	GSM 850 EGSM 900	PCL=5	223	mA
				PCL=12	150	
				PCL=19	120	
			DCS 1800 PCS 1900	PCL=0	166	mA
PCL=7	130					
PCL=15	115					
Data mode GPRS(3Rx,2Tx)	GSM 850 EGSM 900	PCL=5	410	mA		
		PCL=12	185			
		PCL=19	130			
	DCS 1800 PCS 1900	PCL=0	300	mA		
		PCL=7	155			
		PCL=15	122			
I _{VBAT-peak}	Peak current	During Tx burst	2	A		

* In above table the current consumption value is the typical one of the module tested in laboratory. In the mass production stage, there may be differences among each individual.

5.9 Radio Characteristics

5.9.1 Module RF Output Power

The following table shows the module conducted output power, it is followed by the 3GPP TS 05.05 technical specification requirement.

Table 23: SIM900E GSM 900 and GSM 850 conducted RF output power

GSM 900 and EGSM 850			
PCL	Nominal output power (dBm)	Tolerance (dB) for conditions	
		Normal	Extreme
5	33	±3	±4
6	31	±3	±4
7	29	±3	±4
8	27	±3	±4
9	25	±3	±4
10	23	±3	±4
11	21	±3	±4
12	19	±3	±4
13	17	±3	±4
14	15	±3	±4
15	13	±3	±4
16	11	±5	±6
17	9	±5	±6
18	7	±5	±6
19-31	5	±5	±6

Table 24: SIM900E DCS 1800 and PCS 1900 conducted RF output power

DCS 1800 and PCS 1900			
PCL	Nominal output power (dBm)	Tolerance (dB) for conditions	
		Normal	Extreme
0	30	±3	±4
1	28	±3	±4
2	26	±3	±4
3	24	±3	±4
4	22	±3	±4
5	20	±3	±4
6	18	±3	±4
7	16	±3	±4
8	14	±3	±4
9	12	±4	±5

10	10	±4	±5
11	8	±4	±5
12	6	±4	±5
13	4	±4	±5
14	2	±5	±6
15-28	0	±5	±6

For the module’s output power, the following is should be noted:

At GSM900 and GSM850 band, the module is a class 4 device, so the module’s output power should not exceed 33dBm, and at the maximum power level, the output power tolerance should not exceed +/-2dB under normal condition and +/-2.5dB under extreme condition.

At DCS1800 and PCS1900 band, the module is a class 1 device, so the module’s output power should not exceed 30dBm, and at the maximum power level, the output power tolerance should not exceed +/-2dB under normal condition and +/-2.5dB under extreme condition.

5.9.2 Module RF Receive Sensitivity

The following table shows the module’s conducted receive sensitivity, it is tested under static condition.

Table 25: SIM900E conducted RF receive sensitivity

Frequency	Receive sensitivity (Typical)	Receive sensitivity(Max)
GSM850	-109dBm	-107dBm
EGSM900	-109dBm	-107dBm
DCS1800	-109dBm	-107dBm
PCS1900	-109dBm	-107dBm

5.9.3 Module Operating Frequencies

The following table shows the module’s operating frequency range; it is followed by the 3GPP TS 05.05 technical specification requirement.

Table 26: SIM900E operating frequencies

Frequency	Receive	Transmit
GSM850	869 ~ 894MHz	824 ~ 849 MHz
EGSM900	925 ~ 960MHz	880 ~ 915MHz
DCS1800	1805 ~ 1880MHz	1710 ~ 1785MHz
PCS1900	1930 ~ 1990MHz	1850 ~ 1910MHz

6 Manufacturing

6.1 Top and Bottom View of SIM900E



Figure 39: Top, bottom and side view of SIM900E

Note: These test points are only used for module manufacturing and testing. They are not for customer using.

The following figure marked the information of SIM900E module.

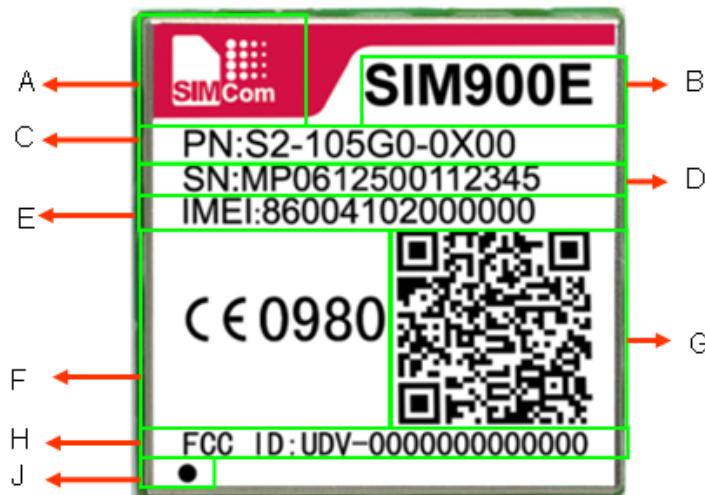

Figure 40: Module information

Table 27: illustration of module information

Item	Description
A	Logo of SIMCom

B	Module name
C	Module part number
D	Module serial number
E	Module IMEI
F	CE authenticated logo
G	2-dimensional bar code
H	FCC authenticated logo
J	First pin mark

6.2 Typical Solder Reflow Profile

Please refer to the recommended ramp-soak-spike reflow profile as following shows

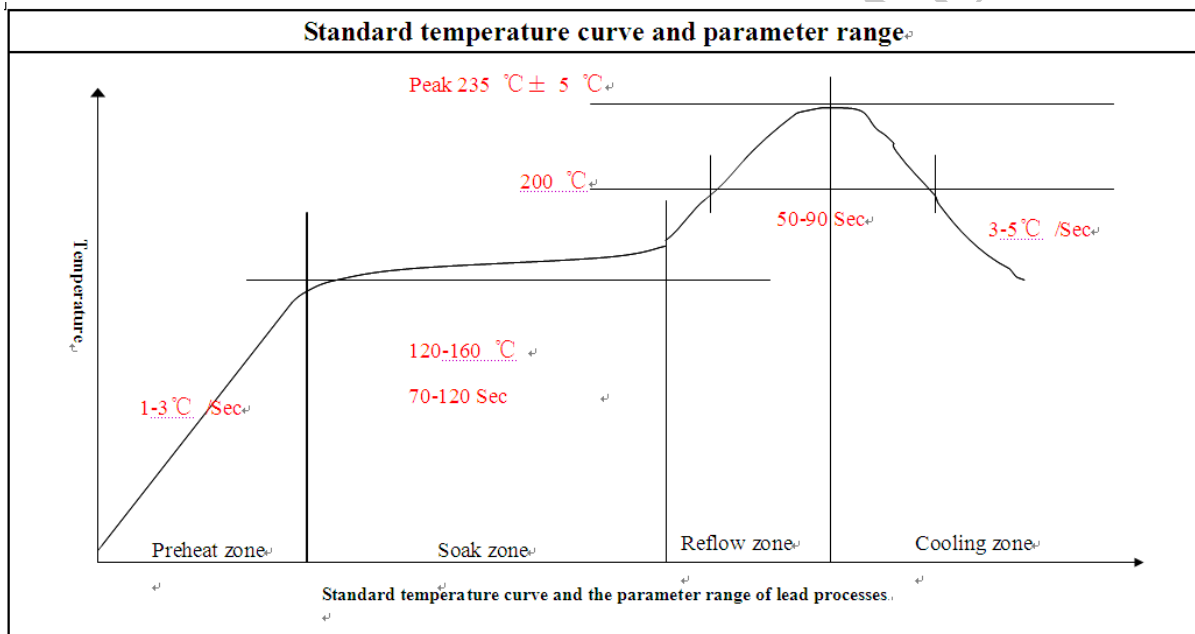

Figure 41: Standard temperature curve and the parameter range of lead processes

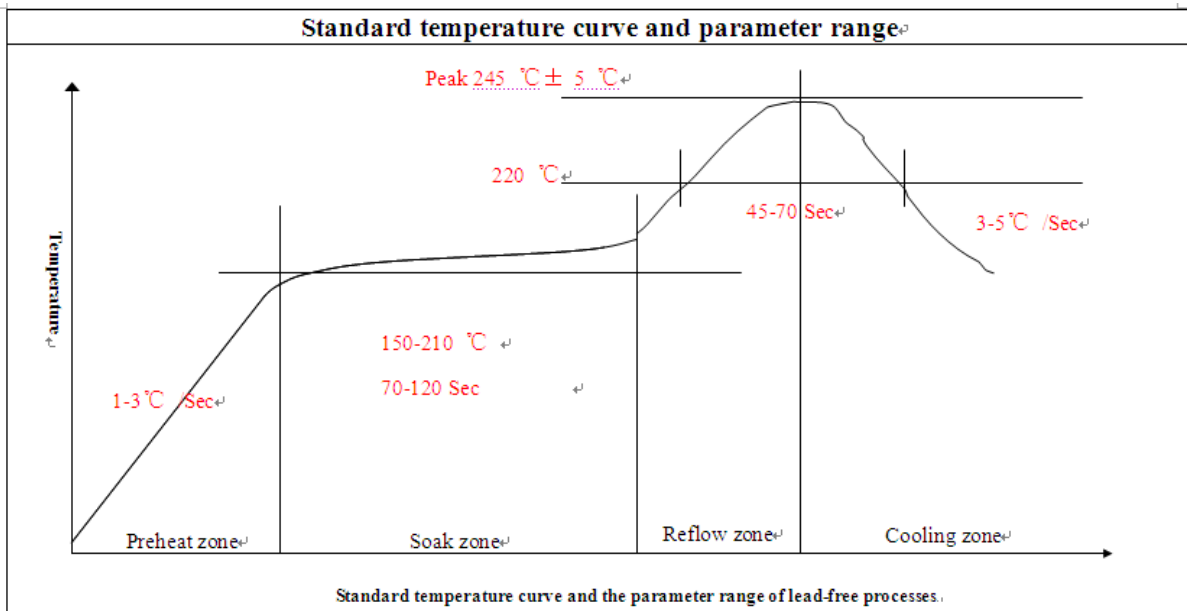

Figure 42: Standard temperature curve and the parameter range of lead-free processes

SIMCOM CONFIDENTIAL

Appendix

A. Related Documents

Table 28: Related documents

SN	Document name	Remark
[1]	SIM900_AT Command Manual	SIM900 AT Command Manual
[2]	AN_SIM900_TCPIP	TCP/IP Applications User Manual
[3]	SIM900_Multiplexer User Manual_Application Note	SIM900 Multiplexer User Manual Application Note
[4]	AN_SIM900 Series_Update Tool_UGD	SIM900 Series Update Tool User Guide
[5]	AN_SIM900_AUDIO	Applications Note About SIM900 Audio
[6]	AN_Serial Port	Application Note About Serial Port
[7]	AN_SIM900E-TE PCB Layout & Schematic for Reference	Application Note About SIM900E-TE PCB Layout & Schematic
[8]	ITU-T Draft new recommendation V.25ter:	Serial asynchronous automatic dialing and control
[9]	GSM 07.07:	Digital cellular telecommunications (Phase 2+); AT command set for GSM Mobile Equipment (ME)
[10]	GSM 07.10:	Support GSM 07.10 multiplexing protocol
[11]	GSM 07.05:	Digital cellular telecommunications (Phase 2+); Use of Data Terminal Equipment – Data Circuit terminating Equipment (DTE – DCE) interface for Short Message Service (SMS) and Cell Broadcast Service (CBS)
[12]	GSM 11.14:	Digital cellular telecommunications system (Phase 2+); Specification of the SIM Application Toolkit for the Subscriber Identity Module – Mobile Equipment (SIM – ME) interface
[13]	GSM 11.11:	Digital cellular telecommunications system (Phase 2+); Specification of the Subscriber Identity Module – Mobile Equipment (SIM – ME) interface
[14]	GSM 03.38:	Digital cellular telecommunications system (Phase 2+); Alphabets and language-specific information
[15]	GSM 11.10	Digital cellular telecommunications system (Phase 2); Mobile Station (MS) conformance specification; Part 1: Conformance specification

B. Terms and Abbreviations







Table 29: Terms and Abbreviations

Abbreviation	Description
ADC	Analog-to-Digital Converter
AMR	Adaptive Multi-Rate
CS	Coding Scheme
CSD	Circuit Switched Data
CTS	Clear to Send
DTE	Data Terminal Equipment (typically computer, terminal, printer)
DTR	Data Terminal Ready
DTX	Discontinuous Transmission
EFR	Enhanced Full Rate
EGSM	Enhanced GSM
ESD	Electrostatic Discharge
ETS	European Telecommunication Standard
FR	Full Rate
GPRS	General Packet Radio Service
GSM	Global Standard for Mobile Communications
HR	Half Rate
IMEI	International Mobile Equipment Identity
Li-ion	Lithium-Ion
MO	Mobile Originated
MS	Mobile Station (GSM engine), also referred to as TE
MT	Mobile Terminated
PAP	Password Authentication Protocol
PBCCH	Packet Broadcast Control Channel
PCB	Printed Circuit Board
PCL	Power Control Level
PCS	Personal Communication System, also referred to as GSM 1900
PDU	Protocol Data Unit
PPP	Point-to-point protocol
RF	Radio Frequency
RMS	Root Mean Square (value)
RTC	Real Time Clock
RX	Receive Direction
SIM	Subscriber Identification Module
SMS	Short Message Service
TE	Terminal Equipment, also referred to as DTE
TX	Transmit Direction

UART	Universal Asynchronous Receiver & Transmitter
URC	Unsolicited Result Code
USSD	Unstructured Supplementary Service Data
Phonebook abbreviations	
FD	SIM fix dialing phonebook
LD	SIM last dialing phonebook (list of numbers most recently dialed)
MC	Mobile Equipment list of unanswered MT calls (missed calls)
ON	SIM (or ME) own numbers (MSISDNs) list
RC	Mobile Equipment list of received calls
SM	SIM phonebook
NC	Not connect

C. Safety Caution

Table 30: Safety caution

Marks	Requirements
	When in a hospital or other health care facility, observe the restrictions about the use of mobiles. Switch the cellular terminal or mobile off, medical equipment may be sensitive to not operate normally for RF energy interference.
	Switch off the cellular terminal or mobile before boarding an aircraft. Make sure it is switched off. The operation of wireless appliances in an aircraft is forbidden to prevent interference with communication systems. Forget to think much of these instructions may lead to the flight safety or offend against local legal action, or both.
	Do not operate the cellular terminal or mobile in the presence of flammable gases or fumes. Switch off the cellular terminal when you are near petrol stations, fuel depots, chemical plants or where blasting operations are in progress. Operation of any electrical equipment in potentially explosive atmospheres can constitute a safety hazard.
	Your cellular terminal or mobile receives and transmits radio frequency energy while switched on. RF interference can occur if it is used close to TV sets, radios, computers or other electric equipment.
	Road safety comes first! Do not use a hand-held cellular terminal or mobile when driving a vehicle, unless it is securely mounted in a holder for hands free operation. Before making a call with a hand-held terminal or mobile, park the vehicle.
	GSM cellular terminals or mobiles operate over radio frequency signals and cellular networks and cannot be guaranteed to connect in all conditions, for example no mobile fee or a invalid SIM card. While you are in this condition and need emergent help, please remember using emergency calls. In order to make or receive calls, the cellular terminal or mobile must be switched on and in a service area with adequate cellular signal strength. Some networks do not allow for emergency call if certain network services or phone features are in use (e.g. lock functions, fixed dialing etc.). You may have to deactivate those features before you can make an emergency call. Also, some networks require that a valid SIM card be properly inserted in the cellular terminal or mobile.

Contact us:

Shanghai SIMCom Wireless Solutions Ltd.

Add: SIM Technology Building, No.633, Jinzhong Road, Changning District, Shanghai P.R. China
200335

Tel: +86 21 3235 3300

Fax: +86 21 3235 3301

URL: www.sim.com/wm

SIMCOM CONFIDENTIAL FILE