

USER'S MANUAL

PGH Single Package Rooftop

Gas Heating/Electric Cooling Units

Sizes 210 – 300

18 to 25 Tons

NOTE TO INSTALLER

This manual should be left with the equipment owner.

WARNING: If the information in this manual is not followed exactly, a fire or explosion may result causing property damage, personal injury or loss of life.

- Do not store or use gasoline or other flammable vapors and liquids in the vicinity of this or any other appliance.
- **WHAT TO DO IF YOU SMELL GAS**
 - Do not try to light any appliance.
 - Do not touch any electrical switch; do not use any phone in your building.
 - Immediately call your gas supplier from a neighbor's phone. Follow the gas supplier's instructions.
 - If you cannot reach your gas supplier, call the fire department.
- Installation and service must be performed by a qualified installer, service agency or the gas supplier.

WARNING: Improper installation, adjustment, alteration, service or maintenance can cause injury or property damage. Refer to this manual. For assistance or additional information consult a qualified installer, service agency, or the gas supplier.

WARNING: Before performing recommended maintenance, be sure main power switch to unit is turned off and lockout tag is installed. Electrical shock could cause personal injury.

Your combination heating/cooling unit is equipped with direct spark ignition and induced draft power combustion blower.

WARNING: Burners will light automatically. Do not attempt to light by hand; personal injury may result.

TO LIGHT UNIT

DANGER:

1. Do not turn off the electrical power to unit without first turning off the gas supply.
2. Before attempting to start the gas heating section, familiarize yourself with all the procedures that must be followed.
3. Never attempt to manually light the burners on the unit with a match, lighter, or any other flame. If the electric sparking device fails to light the burners, refer to the shutdown procedures, then call your dealer as soon as possible.

If you do not follow these instructions exactly, a fire or explosion may result, causing property damage, injury, or loss of life.

See Fig. 1 for location of gas valve. Refer to Fig. 2 while proceeding with the following steps.

I. STEP 1

Set room thermostat to the lowest temperature setting and set SYSTEM switch to OFF position.

II. STEP 2

Close the external manual gas valve.

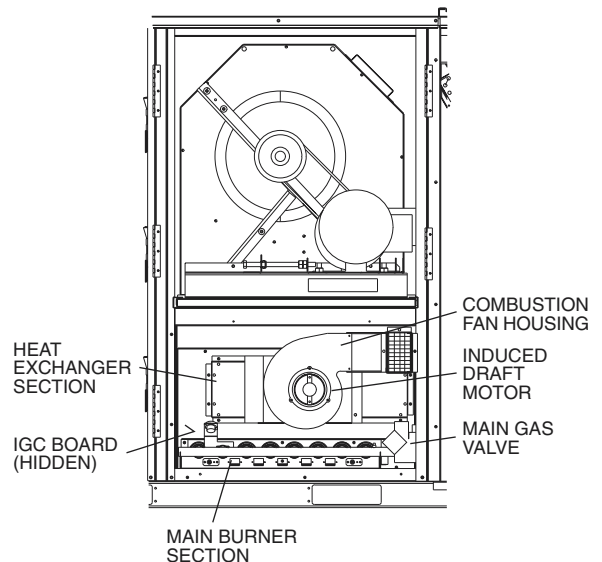

LEGEND

IGC — Integrated Gas Controller

Fig. 1 — Typical Gas Heating Section

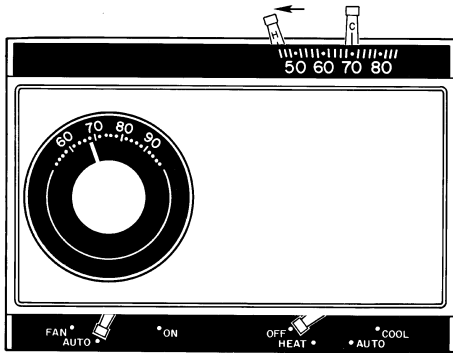

STEP 1

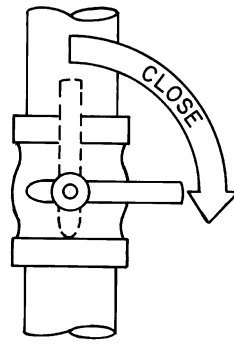

STEP 2

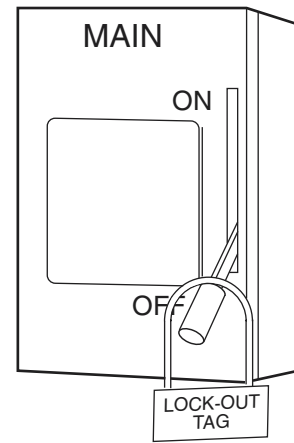

STEP 3

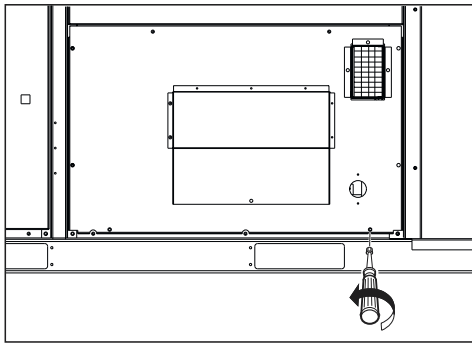

STEP 4

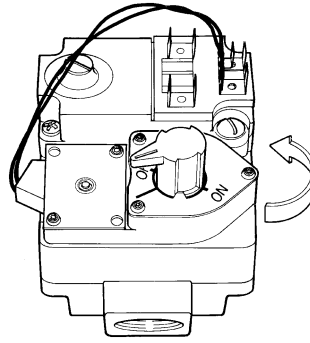

STEP 5

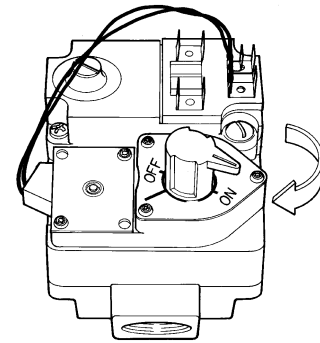

STEP 6

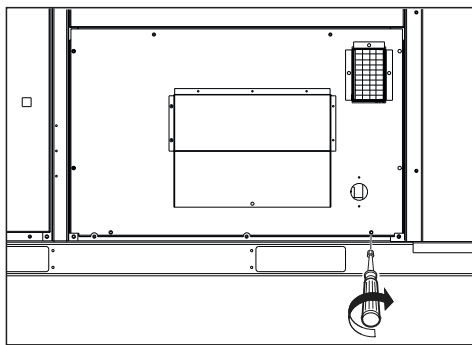

STEP 7

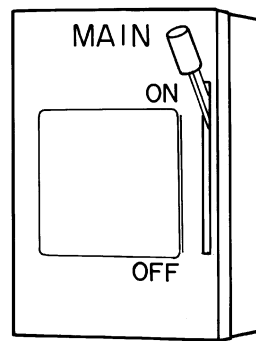

STEP 8

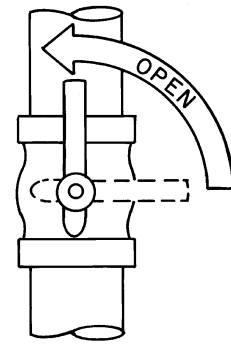

STEP 9

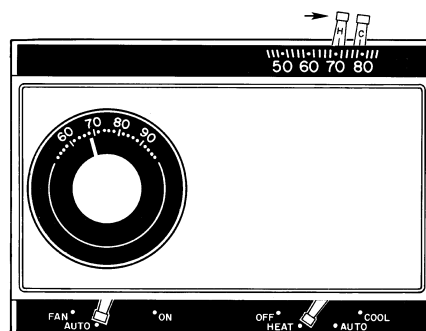

STEP 10

Fig. 2 — To Light Unit

III. STEP 3

Turn off the electrical supply to the unit and install lockout tag.

IV. STEP 4

Remove the heat section access panel.

V. STEP 5

Turn the control dial on the internal gas valve counterclockwise  to the OFF position and wait 5 minutes.

VI. STEP 6

Turn control dial on internal gas valve clockwise  to ON position.

VII. STEP 7

Replace the heat section access panel.

VIII. STEP 8

Remove lockout tag and turn on the electrical supply to unit.

IX. STEP 9

Open the external gas valve.

X. STEP 10

Set room thermostat selector slightly above room temperature and set system switch to HEAT position to start the unit. The induced-draft combustion air fan will start. Main burners light within 30 seconds. Indoor blower will start within a few minutes of main gas ignition.

XI. STEP 11

Set the temperature selector on room thermostat to desired setting.

 **WARNING:** If the main burners fail to light, or the blower fails to come on, shut down gas heating section and call your dealer for service. Failure to follow these requirements could result in serious personal injury.

TO SHUT UNIT OFF

 **WARNING:** Do not turn off the electrical power to unit without first turning off the gas supply. Failure to follow these procedures can result in serious fire or personal injury.

See Fig. 1 for location of gas valve. Refer to Fig. 3 while proceeding with the following steps.

I. STEP 1

Set room thermostat to lowest temperature setting and set SYSTEM switch to OFF position.

II. STEP 2

Close the external manual gas valve.

III. STEP 3

Turn off the electrical power supply to the unit and install lockout tag.

IV. STEP 4

Remove the heat section access panel.

V. STEP 5

Turn the control dial on the internal gas valve counterclockwise  to the OFF position.

VI. STEP 6

Replace the heat section access panel.

VII. STEP 7

If unit is being shut down because of a malfunction, call your dealer as soon as possible.

If unit is being shut down because the heating season has ended, restore electrical power to the unit to ensure operation of the cooling system during the cooling season.

Should overheating occur, or the gas supply fail to shut off, shut off the manual gas valve to the unit before shutting off the electrical supply.

Do not use this unit if any part has been under water. Immediately call a qualified service technician to inspect the unit and to replace any part of the control system and any gas control which has been under water.

MAINTAINING YOUR UNIT

All maintenance should be handled by skilled, experienced personnel. Your dealer can help you establish a standard procedure.

For your safety, keep the area around the unit clear and free of combustible materials, gasoline and other flammable liquids and vapors.

To assure proper functioning of the unit, flow of combustion and ventilating air must not be obstructed from reaching the unit. Clearance of at least 6 ft on all sides is required.

ROUTINE MAINTENANCE AND CARE FOR THE EQUIPMENT OWNER

Before proceeding with those things you might want to maintain yourself, please carefully consider the following:

WARNING:

1. TURN OFF GAS SUPPLY AND ELECTRICAL POWER TO YOUR UNIT BEFORE SERVICING OR PERFORMING MAINTENANCE.
2. Do not turn off electrical power to this unit without first turning off the gas supply.
3. When removing access doors or performing maintenance functions inside your unit, be aware of sharp sheet metal parts and screws. Although special care has been taken to reduce sharp edges to a minimum, be extremely careful when handling parts or reaching into the unit.

I. AIR FILTER(S)

Air filters should be checked at least every 3 or 4 weeks and changed or cleaned whenever they become dirty. Table 1 indicates the correct filter size for your unit. Open the filter access panel to replace or inspect the filters. All units have filter tracks into which the filters slide. Remove the filters by pulling the filter slide outward from the track. See Fig. 4 for filter access panel location. Note the direction of flow arrows on the filter frame.

If you have difficulty in locating your air filter in the return-air duct system, or if you have questions concerning proper filter maintenance, contact your dealer for instructions. When replacing your unit filters, always use the same size and type of filter that was originally supplied by the installer.

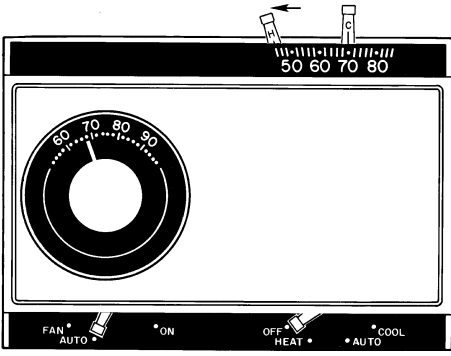

STEP 1

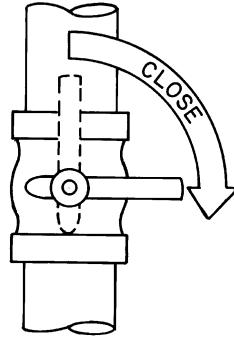

STEP 2

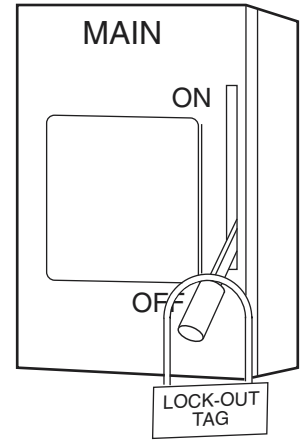

STEP 3

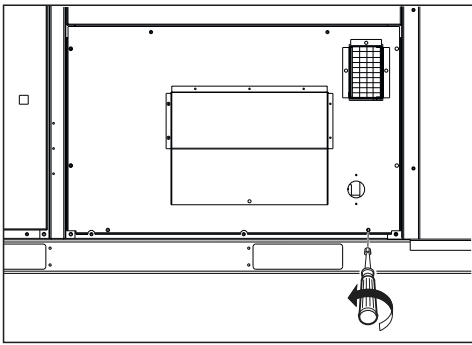

STEP 4

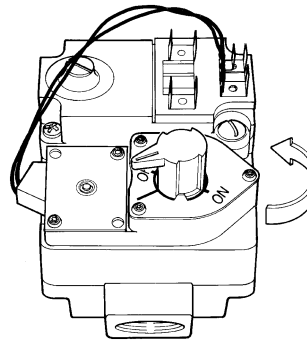

STEP 5

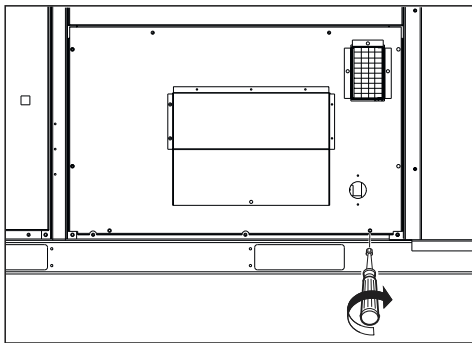

STEP 6

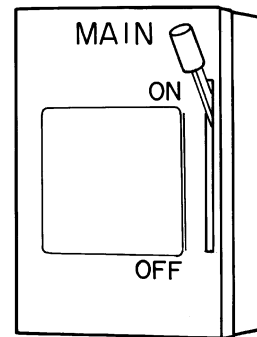

STEP 7

Fig. 3 — To Shut Unit Off

Units with outdoor air capability have cleanable filters for the outdoor air. These filters should be checked annually and cleaned as necessary. Remove by pulling out the middle of the hood top. Push up on the center filter and then remove. Slide the other filters to the center and repeat.

⚠ WARNING: Never operate your unit without filters in place. Failure to heed this warning may result in damage to the blower motor and/or compressor. An accumulation of dust and lint on internal parts of your unit can cause loss of efficiency and in some cases, fire.

Table 1 — Indoor Air Filter Data

UNIT PGH	TYPE OF FILTER	QUANTITY...SIZE (in.)
210, 240	Standard Throwaway	9...16 x 25 x 2
300	Standard Throwaway	9...18 x 24 x 2

II. HEAT EXCHANGER

To ensure dependable and efficient heating operation, the heat exchanger should be checked by a qualified maintenance person before each heating season, and cleaned when necessary. This checkout should not be attempted by anyone not having the required expertise and equipment to do the job properly. Checking and/or cleaning the heat exchanger involves removing the gas controls assembly and the flue collector box cover and, when completed, reinstalling the gas controls assembly for proper operation. Also, the flue collector box cover must be replaced correctly so that a proper seal is maintained. Contact your dealer for the required periodic maintenance.

III. FANS AND BELTS

Periodically check the condition of fan wheels and housings, and belt tension. When service is necessary, call your dealer.

IV. EVAPORATOR, CONDENSER, AND COMBUSTION FAN MOTORS

Lubrication is not recommended. Bearings will not require lubrication for at least 5 years of normal operation. After 5 years, motor life can be extended by having the motors serviced at an authorized motor service shop.

V. FAN SHAFT BEARINGS

Lubrication should only be done by qualified service personnel. Contact your dealer for the required annual maintenance.

VI. EVAPORATOR AND CONDENSER COILS

Cleaning of the coils should only be done by qualified service personnel. Contact your dealer for the required annual maintenance.

VII. CONDENSATE DRAIN

The drain pan and condensate drain line should be checked and cleaned at the same time the cooling coils are checked by your dealer.

VIII. COMPRESSORS

All compressors are factory shipped with a normal charge of the correct type refrigerant grade oil in them and should rarely require additional oil. The service technician must be certain the proper oil level is maintained in the compressor when it is installed and running.

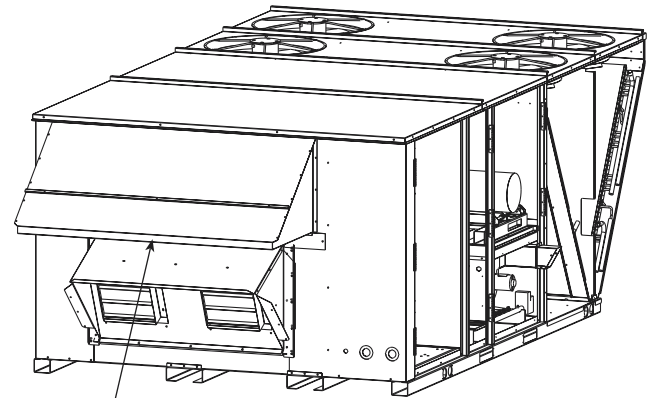

PULL OUT CENTER OF HOOD TO RELEASE OUTDOOR AIR FILTER FROM TRACK

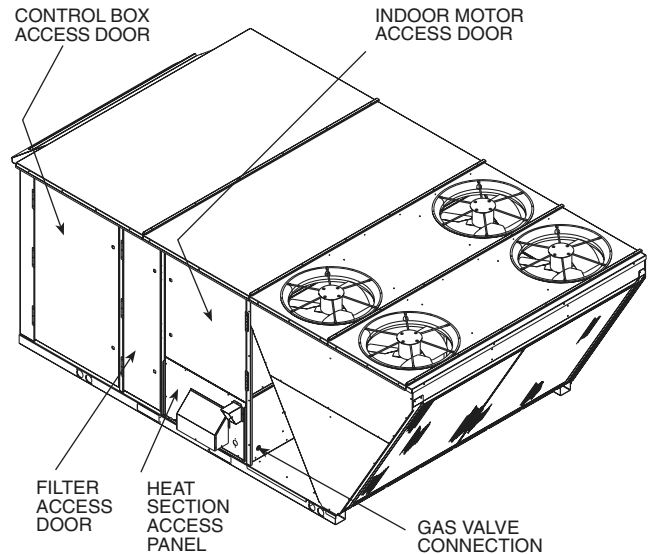

Fig. 4 — Panel and Filter Locations

IX. CONDENSER FAN

⚠ WARNING: Do not poke sticks, screwdrivers, or any other object into revolving fan blades. Severe bodily injury may result.

The fan must be kept free of all obstructions to ensure proper cooling. Contact your dealer for any required service.

X. ELECTRICAL CONTROLS AND WIRING

Electrical controls are difficult to check without proper instrumentation; therefore, if there are any discrepancies in the operating cycle, contact your dealer and request service.

XI. INTEGRATED GAS CONTROLLER (IGC)

The IGC board incorporates an LED that emits a flashing light to indicate an alarm code. If the furnace section will not operate and the LED is flashing a code (1 to 9 flashes in succession), contact your dealer and request service. See Fig. 1.

XII. REFRIGERANT CIRCUITS

The refrigerant circuits are difficult to check for leaks without the proper equipment; therefore, if inadequate cooling is suspected, contact your dealer for service.

XIII. COMBUSTION AREA AND VENT SYSTEM

The combustion area and vent system should be visually inspected before each heating season. The normal accumulation of dirt, soot, rust, and scale can result in loss of efficiency and improper performance if allowed to build up.

⚠ WARNING: If your unit makes an especially loud noise when the main burners are ignited, shut down the heating section and call your dealer.

See Fig. 1 and proceed as follows to inspect the combustion area and power-venting system of your unit.

1. Turn off electrical power (install disconnect tag) and gas supply to your unit.
2. Remove burner compartment access panel.
3. Using a flashlight, carefully inspect the burner areas for dirt, soot, or scale.

⚠ CAUTION: If dirt, soot, rust or scale accumulations are found, call your dealer and do not operate your heating section.

4. When you have completed your inspection, follow the start-up procedures in this manual to restore your unit to operation.
5. Observe unit heating operation, and watch the burner flame with the access panel removed to see if it is bright blue. If you observe a suspected malfunction, or that the burner flames are not bright blue, call your dealer. See Fig. 5. Some yellow flame may be present due to the panel being removed.
6. Replace burner compartment access panel.

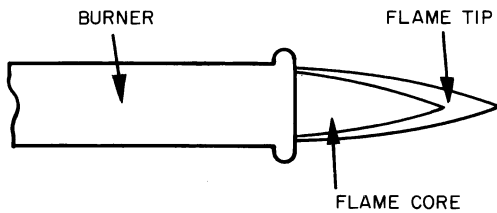

Fig. 5 — Proper Flame Appearance

XIV. UNIT PANELS

After performing any maintenance or service on the unit, be sure all panels are securely fastened in place to prevent rain

from entering unit cabinet and to prevent disruption of the correct unit airflow pattern.

REGULAR DEALER MAINTENANCE

In addition to the type of routine maintenance you might be willing to perform, your unit should be inspected regularly by a properly trained service technician. An inspection (preferably each year, but at least every other year) should include the following:

1. Inspection of all flue product passages — including the burners, combustion baffles, heat exchanger, flue collector box, and vent pipe.
2. Inspection of all combustion-air and ventilation-air passages and openings.
3. Close inspection of all gas pipes leading to and inside your unit.
4. Inspection, and if required, cleaning of the condenser and evaporator coils.
5. Inspection, and if required, cleaning of the evaporator drain pan.
6. Inspection, cleaning, and lubrication of blower wheel housing and motor.
7. Inspection of all supply-air and return-air ducts for leaks, obstructions, and insulation integrity. Any problems found should be resolved at this time.
8. Inspection of the unit base to ensure that no cracks, gaps, etc., exist which may cause a hazardous condition.
9. Inspection of the unit casing for signs of deterioration.
10. Inspection of all electrical wiring and components to assure proper connection.
11. Inspection for leaks in the refrigerant circuit. Pressure-check to determine appropriate refrigerant charge.
12. Operational check of the unit to determine working conditions. Repair or adjustment should be made at this time.
13. Your servicing dealer may offer an economical service contract that covers seasonal inspections. Ask for further details.

Complete Service Instructions can be found in the unit Installation, Start-Up and Service Instructions.

BEFORE YOU CALL FOR SERVICE CHECK FOR SEVERAL EASILY SOLVED PROBLEMS

If insufficient heating or cooling is suspected:

() Check for sufficient airflow. Check the air filter for dirt. Check for blocked return-air or supply-air grilles. Be sure they are open and unobstructed. If these checks do not reveal the cause, call your servicing dealer.

If your unit is not operating at all, check the following list for easy solutions:

() Check to be sure that your thermostat temperature selector is set above the indoor temperature during the heating season, or below the indoor temperature during the cooling season. Be sure the SYSTEM switch in the proper HEAT or COOL position and not in the OFF position.

() Is the electrical supply switch on? Are any fuses blown, or has the circuit breaker tripped?

() During the heating season, check the manual gas shut-off valve. Is this lever parallel with the pipe, indicating that the valve is open? Or is the lever at the right angle, indicating that the valve is closed? If closed, has the gas been shut off for safety reasons? Otherwise, you may open the valve and follow the start-up procedures listed in this manual.

NOTE: Before proceeding with the next check, turn off the electrical power supply to the unit. Remove the control access door.

() During the heating season, check the control dial on the gas valve. Is it in the ON position? If it is not, be sure it has not been turned off for the purpose of safety. If nothing else is incorrect, follow the start-up procedures in this manual.

() If your unit still fails to operate, call your servicing dealer for troubleshooting and repairs. Specify the model and serial numbers of your unit. (Record them in this manual in the space provided.) If the dealer knows exactly which unit you have, he may be able to offer suggestions over the phone, or save valuable time through knowledgeable preparation for the service call.

IN CASE OF TROUBLE

If, after performing the above, unit performance is unsatisfactory, shut off the unit and call your dealer.

Dealer's Name _____

Telephone No. _____

Unit Model _____

Unit Serial Number _____