

FX_{2N}

FX2N-16CCL-M CC-Link SYSTEM MASTER BLOCK

HARDWARE MANUAL

JY992D93201A

This manual contains text, diagrams and explanations which will guide the reader in the correct installation and operation of the FX_{2N}-16CCL-M CC-Link SYSTEM MASTER BLOCK. It should be read and understood before attempting to install or use the unit. Further information can be found in the FX series PLC hardware manuals.



Guidelines for the safety of the user and protection of the FX_{2N}-16CCL-M CC-Link SYSTEM MASTER BLOCK

- If in doubt at any stage during the installation of the FX_{2N}-16CCL-M CC-Link SYSTEM MASTER BLOCK always consult a professional electrical engineer who is qualified and trained to the local and national standards. If in doubt about the operation or use of the FX_{2N}-16CCL-M CC-Link SYSTEM MASTER BLOCK please consult the nearest Mitsubishi Electric distributor.
- Under no circumstances will Mitsubishi Electric be liable or responsible for any consequential damage that may arise as a result of the installation or use of this equipment.
- All examples and diagrams shown in this manual are intended only as an aid to understanding the text, not to guarantee operation. Mitsubishi Electric will accept no responsibility for actual use of the product based on these illustrative examples.
- Owing to the very great variety in possible application of this equipment, you must satisfy yourself as to its suitability for your specific application.

Note's on the symbology used in this manual

At various times through out this manual certain symbols will be used to highlight points of information which are intended to ensure the user's personal safety and protect the integrity of the equipment. Whenever any of the following symbols are encountered, its associated note must be read and understood. Each of the symbols used will now be listed with a brief description of its meaning.

Hardware warnings

-  1) Indicates that the identified danger WILL cause physical and property damage.
-  2) Indicates that the identified danger could POSSIBLY cause physical and property damage.

1. INTRODUCTION

1.1 Associated Manuals

Manual name	Manual number	Description
★FX _{2N} -16CCL-M User's Manual	JY992D93101 (sent separately)	Describes programming and handling of the CC-Link master block FX _{2N} -16CCL-M.
★FX _{1S} /FX _{1N} /FX _{2N} /FX _{2NC} Programming Manual II	JY992D88101 (sent separately)	Explains the instructions in the FX _{1S} /FX _{1N} /FX _{2N} /FX _{2NC} Series PLC.
☆FX _{1N} Hardware Manual	JY992D89301 (packed with product)	Describes the contents related to the hardware such as specification, wiring and mounting of the FX _{1N} Series PLC.
☆FX _{2N} Hardware Manual	JY992D66301 (packed with product)	Describes the contents related to the hardware such as specification, wiring and mounting of the FX _{2N} Series PLC.
☆FX _{2NC} Hardware Manual	JY992D76401 (packed with product)	Describes the contents related to the hardware such as specification, wiring and mounting of the FX _{2NC} Series PLC.
☆FX _{2N} -32CCL User's Manual	JY992D71801 (packed with product)	Describes programming and handling of the CC-Link interface block FX _{2N} -32CCL.

★: Indispensable manual

☆: Manual required depending on equipment used

1.2 Overview

The CC-Link master block FX2N-16CCL-M is a special extension block which assigns an FX Series PLC as the master station of the CC-Link system.

- Remote I/O stations and remote device stations can be connected to the master station (FX Series PLC).
 Master station : Station which controls the data link system
 Remote I/O station : Remote station which handles only the 1-bit information
 Remote device station : Remote station which handles both bit information and word information
- By using the CC-Link interface block FX2N-32CCL, two or more FX Series PLCs can be connected as remote device stations to configure a simple distributed system.

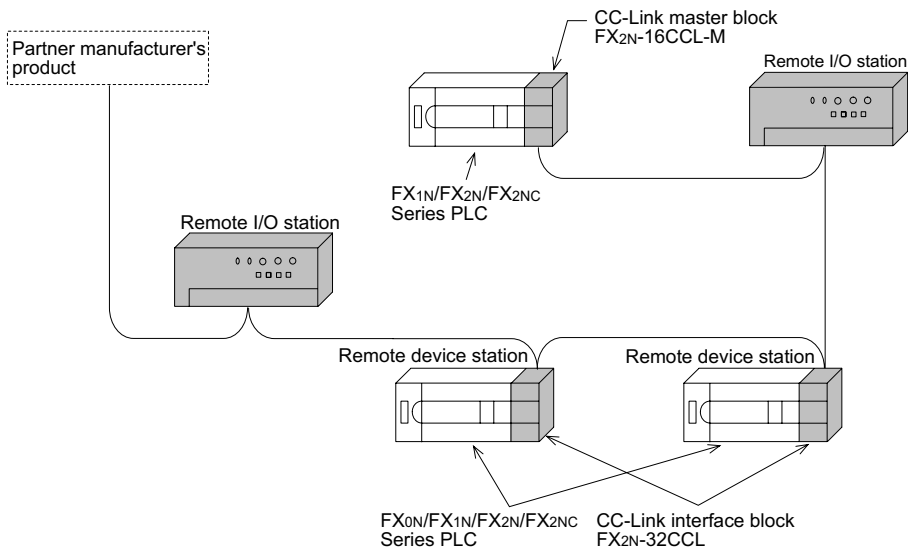





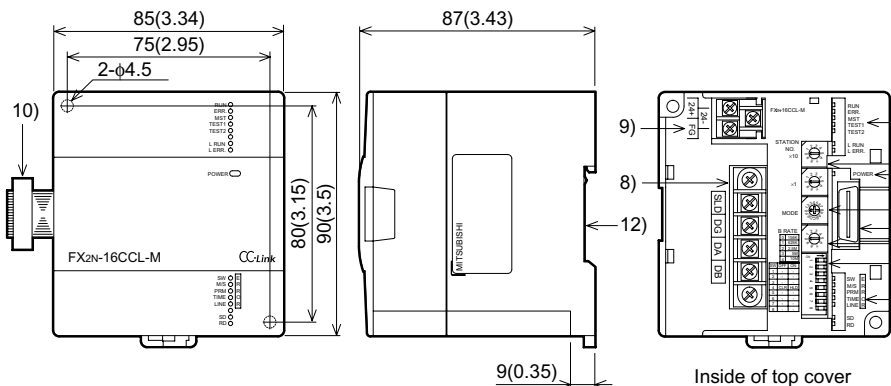

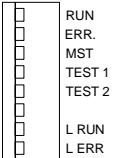
1.3 Dimensions and Setting

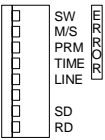
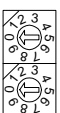
Dimensions: mm (inches) MASS (Weight): 0.4 kg (0.88 lbs)

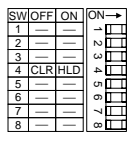

Number	Name	Description			
		LED name	Description	LED status	
				Normal	Error
1)	LED indicators 1 	RUN	ON : Module is normal. OFF: Watchdog time error has occurred.	ON	OFF
		ERR.	Indicates the communication status with the stations set in parameter. ON : Communication error has occurred in all stations. Flashing : Communication error has occurred in some stations.	OFF	ON or flashing
		MST	ON : Set as the master station	ON	OFF
		TEST1	Test result indication	OFF except during test	
		TEST2	Test result indication		
		L RUN	ON : Data link is being executed (host station).	ON	OFF
		L ERR.	ON : Communication error has occurred (host station). Flashing : The settings of the switches 4) to 7) are changed while the power is ON.	OFF	ON or flashing
		2)	Power indicator	POWER	ON : 24V DC is supplied from the outside.

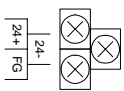
Number	Name	Description																																	
3)	LED indicators 2 	<table border="1"> <tr> <td rowspan="5">E R R O R</td> <td>SW</td> <td>ON : Switch setting error has occurred.</td> <td>OFF</td> <td>ON</td> </tr> <tr> <td>M/S</td> <td>ON : The master station is already present in the same line.</td> <td>OFF</td> <td>ON</td> </tr> <tr> <td>PRM</td> <td>ON : Parameter setting error has occurred.</td> <td>OFF</td> <td>ON</td> </tr> <tr> <td>TIME</td> <td>ON : Data link watchdog timer is actuated (error in all stations).</td> <td>OFF</td> <td>ON</td> </tr> <tr> <td>LINE</td> <td>ON : The cable is broken or the transmission route is affected by noise, etc.</td> <td>OFF</td> <td>ON</td> </tr> <tr> <td></td> <td>SD</td> <td>ON : Data is being transmitted.</td> <td>ON</td> <td>OFF</td> </tr> <tr> <td></td> <td>RD</td> <td>ON : Data is being received.</td> <td>ON</td> <td>OFF</td> </tr> </table>	E R R O R	SW	ON : Switch setting error has occurred.	OFF	ON	M/S	ON : The master station is already present in the same line.	OFF	ON	PRM	ON : Parameter setting error has occurred.	OFF	ON	TIME	ON : Data link watchdog timer is actuated (error in all stations).	OFF	ON	LINE	ON : The cable is broken or the transmission route is affected by noise, etc.	OFF	ON		SD	ON : Data is being transmitted.	ON	OFF		RD	ON : Data is being received.	ON	OFF		
		E R R O R		SW	ON : Switch setting error has occurred.	OFF	ON																												
				M/S	ON : The master station is already present in the same line.	OFF	ON																												
				PRM	ON : Parameter setting error has occurred.	OFF	ON																												
				TIME	ON : Data link watchdog timer is actuated (error in all stations).	OFF	ON																												
			LINE	ON : The cable is broken or the transmission route is affected by noise, etc.	OFF	ON																													
			SD	ON : Data is being transmitted.	ON	OFF																													
	RD	ON : Data is being received.	ON	OFF																															
4)	Station number setting switch STATION NO. × 10  × 1 	Sets the station number of the module. (Default setting at shipment: 00) <Setting range> 00 (because the FX2N-16CCL-M is dedicated to the master station) If "65" or larger number is set, the "SW" and "L ERR." LED indicators turn ON.																																	
		5)	Mode setting switch MODE 	Sets the operation status of the module. (Default setting at shipment: 0) <table border="1"> <thead> <tr> <th>Number</th> <th>Name</th> <th>Description</th> </tr> </thead> <tbody> <tr> <td>0</td> <td>Online</td> <td>Sets connection to data link.</td> </tr> <tr> <td>1</td> <td>(Unusable)</td> <td>—</td> </tr> <tr> <td>2</td> <td>Offline</td> <td>Sets disconnection from data link.</td> </tr> <tr> <td>3</td> <td>Line test 1</td> <td>Refer to USER'S MANUAL.</td> </tr> <tr> <td>4</td> <td>Line test 2</td> <td>Refer to USER'S MANUAL.</td> </tr> <tr> <td>5</td> <td>Parameter verification test</td> <td>Refer to USER'S MANUAL.</td> </tr> <tr> <td>6</td> <td>Hardware test</td> <td>Refer to USER'S MANUAL.</td> </tr> <tr> <td>7</td> <td>(Unusable)</td> <td>Setting error (The SW LED indicator turns ON.)</td> </tr> <tr> <td>8 to A</td> <td>(Unusable)</td> <td>Cannot be set because it is already used inside.</td> </tr> <tr> <td>B to F</td> <td>(Unusable)</td> <td>Setting error (The SW LED indicator turns ON.)</td> </tr> </tbody> </table>	Number	Name	Description	0	Online	Sets connection to data link.	1	(Unusable)	—	2	Offline	Sets disconnection from data link.	3	Line test 1	Refer to USER'S MANUAL.	4	Line test 2	Refer to USER'S MANUAL.	5	Parameter verification test	Refer to USER'S MANUAL.	6	Hardware test	Refer to USER'S MANUAL.	7	(Unusable)	Setting error (The SW LED indicator turns ON.)	8 to A	(Unusable)	Cannot be set because it is already used inside.	B to F
Number	Name	Description																																	
0	Online	Sets connection to data link.																																	
1	(Unusable)	—																																	
2	Offline	Sets disconnection from data link.																																	
3	Line test 1	Refer to USER'S MANUAL.																																	
4	Line test 2	Refer to USER'S MANUAL.																																	
5	Parameter verification test	Refer to USER'S MANUAL.																																	
6	Hardware test	Refer to USER'S MANUAL.																																	
7	(Unusable)	Setting error (The SW LED indicator turns ON.)																																	
8 to A	(Unusable)	Cannot be set because it is already used inside.																																	
B to F	(Unusable)	Setting error (The SW LED indicator turns ON.)																																	
6)	Transmission speed setting switch B RATE <table border="1"> <tr><td>0</td><td>156K</td></tr> <tr><td>1</td><td>625K</td></tr> <tr><td>2</td><td>2.5M</td></tr> <tr><td>3</td><td>5M</td></tr> <tr><td>4</td><td>10M</td></tr> </table> 	0	156K	1	625K	2	2.5M	3	5M	4	10M	Sets the transmission speed of the module. (Default setting at shipment: 0) <table border="1"> <thead> <tr> <th>Number</th> <th>Setting contents</th> </tr> </thead> <tbody> <tr> <td>0</td> <td>156 kbps</td> </tr> <tr> <td>1</td> <td>625 kbps</td> </tr> <tr> <td>2</td> <td>2.5 Mbps</td> </tr> <tr> <td>3</td> <td>5 Mbps</td> </tr> <tr> <td>4</td> <td>10 Mbps</td> </tr> <tr> <td>5 to 9</td> <td>Setting error (The SW and L ERR. LED indicators turn ON.)</td> </tr> </tbody> </table>	Number	Setting contents	0	156 kbps	1	625 kbps	2	2.5 Mbps	3	5 Mbps	4	10 Mbps	5 to 9	Setting error (The SW and L ERR. LED indicators turn ON.)									
		0	156K																																
		1	625K																																
		2	2.5M																																
		3	5M																																
		4	10M																																
		Number	Setting contents																																
0	156 kbps																																		
1	625 kbps																																		
2	2.5 Mbps																																		
3	5 Mbps																																		
4	10 Mbps																																		
5 to 9	Setting error (The SW and L ERR. LED indicators turn ON.)																																		
7)	Condition setting switch 	Sets the operation condition. (Default setting at shipment: All OFF) <table border="1"> <thead> <tr> <th>Number</th> <th>Setting description</th> <th colspan="2">Switch status</th> </tr> <tr> <td></td> <td></td> <th>ON</th> <th>OFF</th> </tr> </thead> <tbody> <tr> <td>SW1 to SW3</td> <td>(Unusable)</td> <td colspan="2">Always OFF</td> </tr> <tr> <td>SW4</td> <td>Input data status in data link faulty station</td> <td>Keep (HLD)</td> <td>Clear (CLR)</td> </tr> <tr> <td>SW5 to SW8</td> <td>(Unusable)</td> <td colspan="2">Always OFF</td> </tr> </tbody> </table>	Number	Setting description	Switch status				ON	OFF	SW1 to SW3	(Unusable)	Always OFF		SW4	Input data status in data link faulty station	Keep (HLD)	Clear (CLR)	SW5 to SW8	(Unusable)	Always OFF														
		Number	Setting description	Switch status																															
				ON	OFF																														
		SW1 to SW3	(Unusable)	Always OFF																															
		SW4	Input data status in data link faulty station	Keep (HLD)	Clear (CLR)																														
SW5 to SW8	(Unusable)	Always OFF																																	
8)	Terminal block 	Connects dedicated CC-Link cables to enable data link. For the connection method, refer to Section 2.3.																																	
		The terminals SLD and FG are connected inside.																																	
9)	Terminal block 	Connects the power supply to operate the master block.																																	
10)	Extension cable	Connects the PLC.																																	
11)	Next step extension connector	Connects an extension equipment.																																	
12)	DIN rail mounting groove	DIN46277: DIN rail mounting groove of 35 mm (1.38") in width																																	

2. Installation and wiring



INSTALLATION PRECAUTIONS

- Use the module in the environment described in the USER'S MANUAL General Specification. Do not use the PLC in a place with dust, soot, conductive dust, corrosive gas or combustible gas, place exposed to high temperature, condensation, wind or rain or place with vibration or impact. Using the module outside the range of the general specification may result in electrical shock, fire, malfunctions, or may damage the PLC.
- When drilling screw holes or performing wiring, make sure that cutting chips, wire chips or other foreign matter does not enter the ventilation window of the module. Such matter may cause fire, failure or malfunction.
- When the installation work is completed, remove the dust protection sheet from the ventilation window of the PLC. If the sheet remains attached, it may cause fire, failure or malfunction.
- Securely connect extension cables to specified connectors. Poor contact may cause malfunction.

WIRING PRECAUTIONS



- Before beginning any installation or wiring work, make sure all phases of the power supply have been shut down from the outside. Incomplete shutdown of the power supply phases may cause electrical shock or damage in the module.
- Following an installation or wiring work, when turning on the power supply and operating the PLC, make sure that the terminal cover provided as an accessory has been attached to the module. Non-attachment of the cover may cause electrical shock.
- For the CC-Link system, use dedicated cables specified by the manufacturer. The performance of the CC-Link system cannot be guaranteed with any cable other than dedicated ones specified by the manufacturer. For the maximum total extension length and the cable length between stations, observe the specification described in USER'S MANUAL. With wiring outside the specification range, normal data transfer cannot be guaranteed.
- Make sure to fix communication cables and power cables connected to the module by placing them in the duct or clamping them. Cables not placed in duct or not clamped may hang or shift, allowing them to be accidentally pulled, which may result in malfunction or damage to the module and the cables.
- When disconnecting a communication/power cable connected to the module, do not hold the cable area. For a cable with connector, hold the connector attached to the module. For a cable connected to a terminal block, loosen screws of the terminal block, then disconnect the cable. If a cable is pulled while it is connected to a module, the module may malfunction or the module and the cable may be damaged.

WIRING PRECAUTIONS



- Perform Class D grounding (solid grounding) with a wire of 2 mm² or more to the grounding terminal in the PLC main units. However, never perform common grounding with a high voltage system.

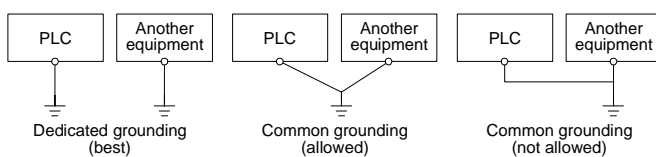

- Do not bundle control cables and communication cables with the main circuit and power cables. Keep control cables and communication cables at least 100 mm away from the main circuit and power cables. Otherwise, electric noise may cause a malfunction.

2.1 Installation

Install the FX2N-16CCL-M on the right side of an FX1N/FX2N/FX2NC Series main unit, extension unit or another extension block. (For the FX2NC Series, the FX2NC-CNV-IF is required.)

The FX2N-16CCL-M can be installed using a DIN rail (DIN 46277, width: 35 mm (1.38 in.)) or directly with M4 (0.16 in.) screws.

In the case of direct installation, provide space of 1 to 2 mm (0.04 to 0.08 in.) between units.

2.2 Dedicated CC-Link Cable

Use dedicated CC-Link cables in the CC-Link system.

If any other cable is used, the performance of the CC-Link system cannot be guaranteed.

2.3 Module Wiring with Dedicated CC-Link Cables

This section describes the connection method of dedicated CC-Link cables.

- The cables can be connected without regard to the station number.
- Make sure to connect a terminal resistor (offered as an accessory of the module) between the terminals DA and DB in modules at both ends.
- In the CC-Link system, the terminal resistor to be connected varies depending on the used cable.
 - When a dedicated CC-Link cable is used: 110 Ω, 1/2 W (brown, brown and brown)
 - When a dedicated high-performance CC-Link cable is used: 130 Ω, 1/2 W (brown, orange and brown)
- The master module can be connected besides to the both ends.
- Star connection is not allowed.
- The figure below shows the connection method.

Important
Make sure to use only one type of cable (dedicated CC-Link cables OR dedicated CC-Link high-performance cables). If both types of cables are used together, normal data transmission cannot be guaranteed.

Point
The shielded dedicated CC-Link cable should go through the terminals SLD and FG in each module, and both ends should be grounded (Class D = solid grounding). The terminals SLD and FG are connected each other inside the module.

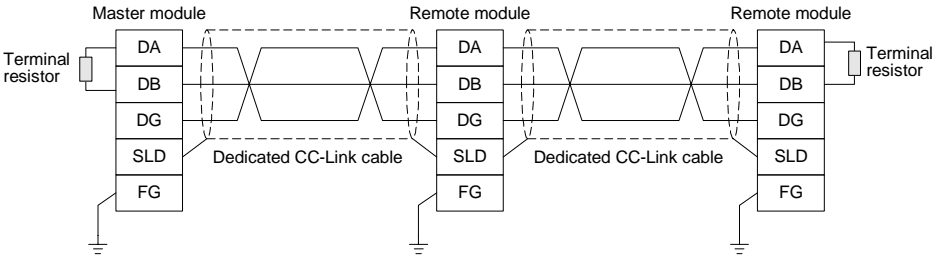

3. SPECIFICATION

3.1 General Specification

Dielectric strength: 500V AC for 1 minute (between the case and the PLC ground)
Other specification is equivalent to that of the PLC main unit.

3.2 Performance Specification

Item	Specification
Applicable function	Master station function (The local station and standby master station functions are not provided.)
CC-Link version	Ver.1.10
Transmission speed	Selectable (by rotary switch) among 156 kbps, 625 kbps, 2.5 Mbps, 5 Mbps and 10 Mbps
Station number	0 (set by rotary switch)
Maximum total cable length (maximum transmission distance)	1,200 m maximum Varies depending on the transmission speed. (Refer to USER'S MANUAL.)
Maximum number of connected modules	<ul style="list-style-type: none"> • Remote I/O stations: 7 maximum (Each station occupies 32 I/O points of the PLC.) • Remote device stations: 8 maximum (The following condition must be satisfied.) $\{(1 \times a) + (2 \times b) + (3 \times c) + (4 \times d)\} \leq 8$ <ul style="list-style-type: none"> a: Number of remote device stations occupying 1 station b: Number of remote device stations occupying 2 stations c: Number of remote device stations occupying 3 stations d: Number of remote device stations occupying 4 stations • Number of remote I/O stations + Number of remote device stations ≤ 15 • "Maximum number of I/O points per system" below shall be satisfied. • For the system configuration calculation, refer to USER'S MANUAL.
Maximum number of I/O points per system	<ul style="list-style-type: none"> • Connection is allowed as far as the following condition is satisfied: (Actual number of I/O points of PLC) + (Number of points occupied by special extension blocks) + (Number of points occupied by FX2N-16CCL-M: 8) + (32 × Number of remote I/O modules) ≤ 256 (FX2N/FX2NC Series PLC) or 128 (FX1N Series PLC) • For the system configuration calculation, refer to USER'S MANUAL.
Number of link points per station	Remote I/O station : Remote I/O = 32/32 (RX/Ry) points Remote device station : Remote I/O = 32/32 (RX/Ry) points Remote register = 4 (RWw) points (master station → remote device station) Remote register = 4 (RWr) points (remote device station → master station)
Communication method	Polling method

Item	Specification
Synchronous method	Frame synchronous method
Encoding method	NRZI method
Transmission path type	Bus (RS-485)
Transmission format	In conformance to HDLC Standard
Error control method	CRC($X^{16}+X^{12}+X^5+1$)
Connection cable	Dedicated CC-Link cable/Dedicated high-performance CC-Link cable *1
RAS function	<ul style="list-style-type: none"> Automatic return function Slave station cutoff function Error detection by link special relay/register
Number of times of parameter registration to EEPROM	Approximately 10,000 times
Connectable PLC	FX1N, FX2N (V 2.20 or later) and FX2NC (V 2.20 or later) *2 Series PLC
Number of occupied I/O points	8 I/O points of FX Series PLC (8 points in total. The ratio between inputs and outputs is arbitrary.)
Communication with PLC	By FROM/TO instructions via the buffer memory
Note	<ul style="list-style-type: none"> Scan method: Asynchronous mode Automatic refresh: Not provided Local station function: Not provided Standby master station function: Not provided Intelligent device station connection function: Not provided
Operation indication	POWER : Lit while 24V DC is supplied from outside. L RUN : Lit while communication is normal. L ERR : Lit when communication error has occurred. SD : Lit while data is being transmitted. RD : Lit while data is being received.
24V DC external power supply	Supplied from 24V DC (150 mA) external terminal block.
5V DC internal power supply	5V DC is self-supplied. 5V DC of PLC is not used.
Accessories	Terminal resistor <ul style="list-style-type: none"> For standard cable: 110 Ω, 1/2 W (color cable: brown, brown and brown), 2 cables For high performance cable: 130 Ω, 1/2 W (color cable: brown, orange and brown), 2 cables Special block number label
MASS (Weight)	0.4 kg (0.88 lbs)

*1 Dedicated CC-Link cables and dedicated high-performance CC-Link cables cannot be used at the same time. Only either type of cables are available.

Attach a terminal resistor in accordance with the cable type.

*2 When an FX2NC Series PLC is connected, the interface FX2NC-CNV-IF is required.

Manual number : JY992D93201

Manual revision : A

Date : JAN. 2001



HEAD OFFICE : MITSUBISHI DENKI BLDG MARUNOUTI TOKYO 100-8310 TELEX : J24532 CABLE MELCO TOKYO
HIMEJI WORKS : 840, CHIYODA CHO, HIMEJI, JAPAN

FX2N

FX2N-16CCL-M CC-Link SYSTEM MASTER BLOCK

HARDWARE MANUAL

JY992D93201A

This manual contains text, diagrams and explanations which will guide the reader in the correct installation and operation of the FX2N-16CCL-M CC-Link SYSTEM MASTER BLOCK. It should be read and understood before attempting to install or use the unit. Further information can be found in the FX series PLC hardware manuals.



Guidelines for the safety of the user and protection of the FX2N-16CCL-M CC-Link SYSTEM MASTER BLOCK

- If in doubt at any stage during the installation of the FX2N-16CCL-M CC-Link SYSTEM MASTER BLOCK always consult a professional electrical engineer who is qualified and trained to the local and national standards. If in doubt about the operation or use of the FX2N-16CCL-M CC-Link SYSTEM MASTER BLOCK please consult the nearest Mitsubishi Electric distributor.
- Under no circumstances will Mitsubishi Electric be liable or responsible for any consequential damage that may arise as a result of the installation or use of this equipment.
- All examples and diagrams shown in this manual are intended only as an aid to understanding the text, not to guarantee operation. Mitsubishi Electric will accept no responsibility for actual use of the product based on these illustrative examples.
- Owing to the very great variety in possible application of this equipment, you must satisfy yourself as to its suitability for your specific application.

Note's on the symbology used in this manual

At various times through out this manual certain symbols will be used to highlight points of information which are intended to ensure the user's personal safety and protect the integrity of the equipment. Whenever any of the following symbols are encountered, its associated note must be read and understood. Each of the symbols used will now be listed with a brief description of its meaning.

Hardware warnings

-  1) Indicates that the identified danger WILL cause physical and property damage.
-  2) Indicates that the identified danger could POSSIBLY cause physical and property damage.

1. INTRODUCTION

1.1 Associated Manuals

Manual name	Manual number	Description
★FX2N-16CCL-M User's Manual	JY992D93101 (sent separately)	Describes programming and handling of the CC-Link master block FX2N-16CCL-M.
★FX1S/FX1N/FX2N/FX2NC Programming Manual II	JY992D88101 (sent separately)	Explains the instructions in the FX1S/FX1N/FX2N/FX2NC Series PLC.
☆FX1N Hardware Manual	JY992D89301 (packed with product)	Describes the contents related to the hardware such as specification, wiring and mounting of the FX1N Series PLC.
☆FX2N Hardware Manual	JY992D66301 (packed with product)	Describes the contents related to the hardware such as specification, wiring and mounting of the FX2N Series PLC.
☆FX2NC Hardware Manual	JY992D76401 (packed with product)	Describes the contents related to the hardware such as specification, wiring and mounting of the FX2NC Series PLC.
☆FX2N-32CCL User's Manual	JY992D71801 (packed with product)	Describes programming and handling of the CC-Link interface block FX2N-32CCL.

- ★: Indispensable manual
- ☆: Manual required depending on equipment used

1.2 Overview

The CC-Link master block FX2N-16CCL-M is a special extension block which assigns an FX Series PLC as the master station of the CC-Link system.

- 1) Remote I/O stations and remote device stations can be connected to the master station (FX Series PLC).
 Master station : Station which controls the data link system
 Remote I/O station : Remote station which handles only the 1-bit information
 Remote device station : Remote station which handles both bit information and word information
- 2) By using the CC-Link interface block FX2N-32CCL, two or more FX Series PLCs can be connected as remote device stations to configure a simple distributed system.

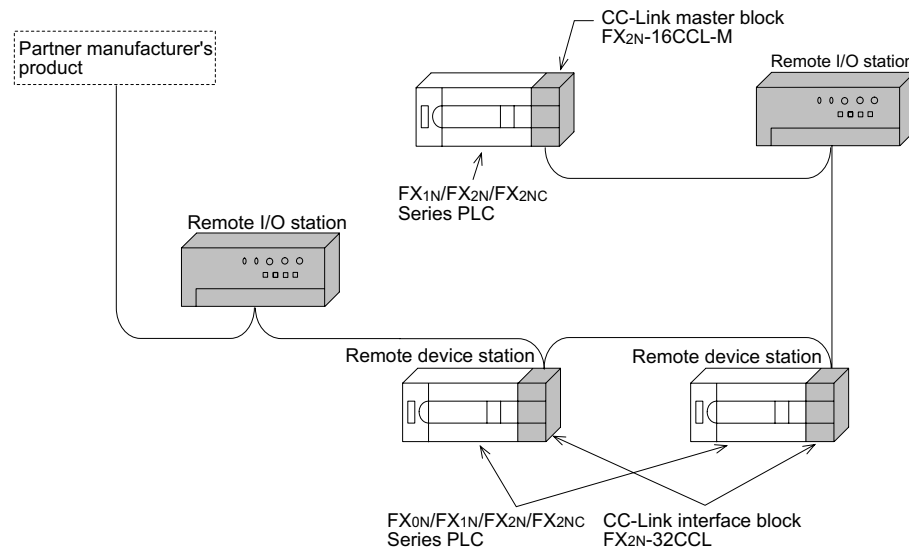

1.3 Dimensions and Setting

Dimensions: mm (inches) MASS (Weight): 0.4 kg (0.88 lbs)

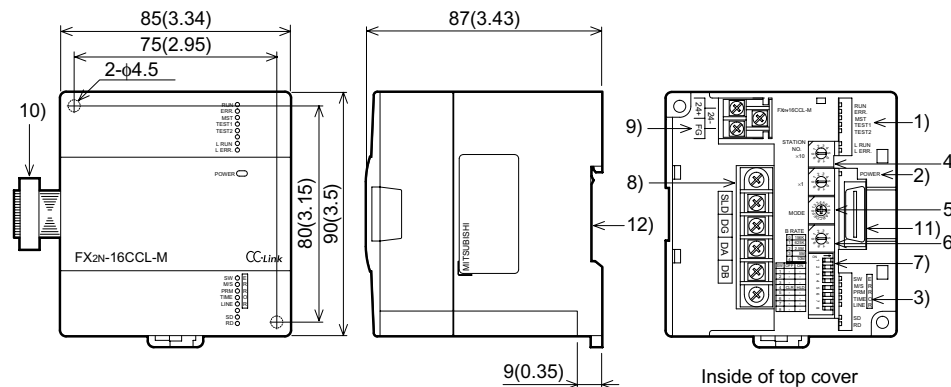

Number	Name	LED name	Description	LED status	
				Normal	Error
1)	LED indicators 1	RUN	ON : Module is normal. OFF: Watchdog time error has occurred.	ON	OFF
		ERR.	Indicates the communication status with the stations set in parameter. ON : Communication error has occurred in all stations. Flashing : Communication error has occurred in some stations.	OFF	ON or flashing
		MST	ON : Set as the master station	ON	OFF
		TEST1	Test result indication	OFF except during test	
		TEST2	Test result indication	OFF except during test	
		L RUN	ON : Data link is being executed (host station).	ON	OFF
		L ERR.	ON : Communication error has occurred (host station). Flashing : The settings of the switches 4) to 7) are changed while the power is ON.	OFF	ON or flashing
2)	Power indicator	POWER	ON : 24V DC is supplied from the outside.	ON	OFF

Number	Name	Description			
		SW	ON	OFF	ON
3)	LED indicators 2	SW	ON : Switch setting error has occurred.	OFF	ON
		M/S	ON : The master station is already present in the same line.	OFF	ON
		PRM	ON : Parameter setting error has occurred.	OFF	ON
		TIME	ON : Data link watchdog timer is actuated (error in all stations).	OFF	ON
		LINE	ON : The cable is broken or the transmission route is affected by noise, etc.	OFF	ON
		SD	ON : Data is being transmitted.	ON	OFF
4)	Station number setting switch	RD	ON : Data is being received.	ON	OFF
		Sets the station number of the module. (Default setting at shipment: 00) <Setting range> 00 (because the FX2N-16CCL-M is dedicated to the master station) If "65" or larger number is set, the "SW" and "L ERR." LED indicators turn ON.			
5)	Mode setting switch	Sets the operation status of the module. (Default setting at shipment: 0)			
		Number	Name	Description	
		0	Online	Sets connection to data link.	
		1	(Unusable)	—	
		2	Offline	Sets disconnection from data link.	
		3	Line test 1	Refer to USER'S MANUAL.	
		4	Line test 2	Refer to USER'S MANUAL.	
		5	Parameter verification test	Refer to USER'S MANUAL.	
		6	Hardware test	Refer to USER'S MANUAL.	
		7	(Unusable)	Setting error (The SW LED indicator turns ON.)	
8 to A	(Unusable)	Cannot be set because it is already used inside.			
B to F	(Unusable)	Setting error (The SW LED indicator turns ON.)			
6)	Transmission speed setting switch	Sets the transmission speed of the module. (Default setting at shipment: 0)			
		Number	Setting contents		
		0	156 kbps		
		1	625 kbps		
		2	2.5 Mbps		
		3	5 Mbps		
4	10 Mbps				
5 to 9	Setting error (The SW and L ERR. LED indicators turn ON.)				
7)	Condition setting switch	Sets the operation condition. (Default setting at shipment: All OFF)			
		Number	Setting description	Switch status	
		SW1 to SW3	(Unusable)	Always OFF	
		SW4	Input data status in data link faulty station	Keep (HLD)	Clear (CLR)
SW5 to SW8	(Unusable)	Always OFF			
8)	Terminal block	Connects dedicated CC-Link cables to enable data link. For the connection method, refer to Section 2.3.			
		The terminals SLD and FG are connected inside.			
9)	Terminal block	Connects the power supply to operate the master block.			
10)	Extension cable	Connects the PLC.			
11)	Next step extension connector	Connects an extension equipment.			
12)	DIN rail mounting groove	DIN46277: DIN rail mounting groove of 35 mm (1.38") in width			

2. Installation and wiring

INSTALLATION PRECAUTIONS

- Use the module in the environment described in the USER'S MANUAL General Specification. Do not use the PLC in a place with dust, soot, conductive dust, corrosive gas or combustible gas, place exposed to high temperature, condensation, wind or rain or place with vibration or impact. Using the module outside the range of the general specification may result in electrical shock, fire, malfunctions, or may damage the PLC.
- When drilling screw holes or performing wiring, make sure that cutting chips, wire chips or other foreign matter does not enter the ventilation window of the module. Such matter may cause fire, failure or malfunction.
- When the installation work is completed, remove the dust protection sheet from the ventilation window of the PLC. If the sheet remains attached, it may cause fire, failure or malfunction.
- Securely connect extension cables to specified connectors. Poor contact may cause malfunction.

WIRING PRECAUTIONS

- Before beginning any installation or wiring work, make sure all phases of the power supply have been shut down from the outside. Incomplete shutdown of the power supply phases may cause electrical shock or damage in the module.
- Following an installation or wiring work, when turning on the power supply and operating the PLC, make sure that the terminal cover provided as an accessory has been attached to the module. Non-attachment of the cover may cause electrical shock.
- For the CC-Link system, use dedicated cables specified by the manufacturer. The performance of the CC-Link system cannot be guaranteed with any cable other than dedicated ones specified by the manufacturer. For the maximum total extension length and the cable length between stations, observe the specification described in USER'S MANUAL. With wiring outside the specification range, normal data transfer cannot be guaranteed.
- Make sure to fix communication cables and power cables connected to the module by placing them in the duct or clamping them. Cables not placed in duct or not clamped may hang or shift, allowing them to be accidentally pulled, which may result in malfunction or damage to the module and the cables.
- When disconnecting a communication/power cable connected to the module, do not hold the cable area. For a cable with connector, hold the connector attached to the module. For a cable connected to a terminal block, loosen screws of the terminal block, then disconnect the cable. If a cable is pulled while it is connected to a module, the module may malfunction or the module and the cable may be damaged.

WIRING PRECAUTIONS

- Perform Class D grounding (solid grounding) with a wire of 2 mm² or more to the grounding terminal in the PLC main units. However, never perform common grounding with a high voltage system.

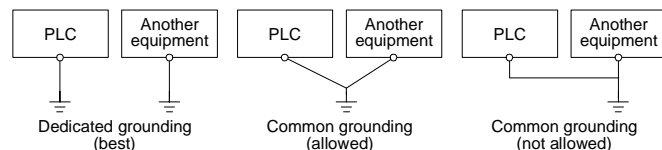

- Do not bundle control cables and communication cables with the main circuit and power cables. Keep control cables and communication cables at least 100 mm away from the main circuit and power cables. Otherwise, electric noise may cause a malfunction.

2.1 Installation

Install the FX2N-16CCL-M on the right side of an FX1N/FX2N/FX2NC Series main unit, extension unit or another extension block. (For the FX2NC Series, the FX2NC-CNV-IF is required.) The FX2N-16CCL-M can be installed using a DIN rail (DIN 46277, width: 35 mm (1.38 in.)) or directly with M4 (0.16 in.) screws. In the case of direct installation, provide space of 1 to 2 mm (0.04 to 0.08 in.) between units.

2.2 Dedicated CC-Link Cable

Use dedicated CC-Link cables in the CC-Link system. If any other cable is used, the performance of the CC-Link system cannot be guaranteed.

2.3 Module Wiring with Dedicated CC-Link Cables

This section describes the connection method of dedicated CC-Link cables.

- The cables can be connected without regard to the station number.
- Make sure to connect a terminal resistor (offered as an accessory of the module) between the terminals DA and DB in modules at both ends.
- In the CC-Link system, the terminal resistor to be connected varies depending on the used cable.
 - When a dedicated CC-Link cable is used: 110 Ω, 1/2 W (brown, brown and brown)
 - When a dedicated high-performance CC-Link cable is used: 130 Ω, 1/2 W (brown, orange and brown)
- The master module can be connected besides to the both ends.
- Star connection is not allowed.
- The figure below shows the connection method.

Important
Make sure to use only one type of cable (dedicated CC-Link cables OR dedicated CC-Link high-performance cables). If both types of cables are used together, normal data transmission cannot be guaranteed.

Point
The shielded dedicated CC-Link cable should go through the terminals SLD and FG in each module, and both ends should be grounded (Class D = solid grounding). The terminals SLD and FG are connected each other inside the module.

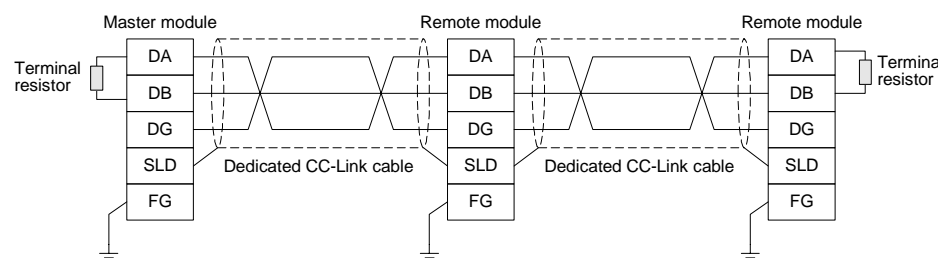

3. SPECIFICATION

3.1 General Specification

Dielectric strength: 500V AC for 1 minute (between the case and the PLC ground)
Other specification is equivalent to that of the PLC main unit.

3.2 Performance Specification

Item	Specification
Applicable function	Master station function (The local station and standby master station functions are not provided.)
CC-Link version	Ver.1.10
Transmission speed	Selectable (by rotary switch) among 156 kbps, 625 kbps, 2.5 Mbps, 5 Mbps and 10 Mbps
Station number	0 (set by rotary switch)
Maximum total cable length (maximum transmission distance)	1,200 m maximum Varies depending on the transmission speed. (Refer to USER'S MANUAL.)
Maximum number of connected modules	<ul style="list-style-type: none"> Remote I/O stations: 7 maximum (Each station occupies 32 I/O points of the PLC.) Remote device stations: 8 maximum (The following condition must be satisfied.) $\{(1 \times a) + (2 \times b) + (3 \times c) + (4 \times d)\} \leq 8$ <ul style="list-style-type: none"> a: Number of remote device stations occupying 1 station b: Number of remote device stations occupying 2 stations c: Number of remote device stations occupying 3 stations d: Number of remote device stations occupying 4 stations Number of remote I/O stations + Number of remote device stations ≤ 15 "Maximum number of I/O points per system" below shall be satisfied. For the system configuration calculation, refer to USER'S MANUAL.
Maximum number of I/O points per system	<ul style="list-style-type: none"> Connection is allowed as far as the following condition is satisfied: (Actual number of I/O points of PLC) + (Number of points occupied by special extension blocks) + (Number of points occupied by FX2N-16CCL-M: 8) + (32 × Number of remote I/O modules) ≤ 256 (FX2N/FX2NC Series PLC) or 128 (FX1N Series PLC) For the system configuration calculation, refer to USER'S MANUAL.
Number of link points per station	Remote I/O station : Remote I/O = 32/32 (RX/RX) points Remote device station : Remote I/O = 32/32 (RX/RX) points Remote register = 4 (RWw) points (master station → remote device station) Remote register = 4 (RWr) points (remote device station → master station)
Communication method	Polling method

Item	Specification
Synchronous method	Frame synchronous method
Encoding method	NRZI method
Transmission path type	Bus (RS-485)
Transmission format	In conformance to HDLC Standard
Error control method	CRC($X^{16}+X^{12}+X^5+1$)
Connection cable	Dedicated CC-Link cable/Dedicated high-performance CC-Link cable *1
RAS function	<ul style="list-style-type: none"> Automatic return function Slave station cutoff function Error detection by link special relay/register
Number of times of parameter registration to EEPROM	Approximately 10,000 times
Connectable PLC	FX1N, FX2N (V 2.20 or later) and FX2NC (V 2.20 or later) *2 Series PLC
Number of occupied I/O points	8 I/O points of FX Series PLC (8 points in total. The ratio between inputs and outputs is arbitrary.)
Communication with PLC	By FROM/TO instructions via the buffer memory
Note	<ul style="list-style-type: none"> Scan method: Asynchronous mode Automatic refresh: Not provided Local station function: Not provided Standby master station function: Not provided Intelligent device station connection function: Not provided
Operation indication	POWER : Lit while 24V DC is supplied from outside. L RUN : Lit while communication is normal. L ERR : Lit when communication error has occurred. SD : Lit while data is being transmitted. RD : Lit while data is being received.
24V DC external power supply	Supplied from 24V DC (150 mA) external terminal block.
5V DC internal power supply	5V DC is self-supplied. 5V DC of PLC is not used.
Accessories	Terminal resistor <ul style="list-style-type: none"> For standard cable: 110 Ω, 1/2 W (color cable: brown, brown and brown), 2 cables For high performance cable: 130 Ω, 1/2 W (color cable: brown, orange and brown), 2 cables Special block number label
MASS (Weight)	0.4 kg (0.88 lbs)

*1 Dedicated CC-Link cables and dedicated high-performance CC-Link cables cannot be used at the same time. Only either type of cables are available. Attach a terminal resistor in accordance with the cable type.

*2 When an FX2NC Series PLC is connected, the interface FX2NC-CNV-IF is required.

Manual number : JY992D93201

Manual revision : A

Date : JAN. 2001

MITSUBISHI ELECTRIC CORPORATION

HEAD OFFICE : MITSUBISHI DENKI BLDG MARUNOUCHI TOKYO 100-8310 TELEX : J24532 CABLE MELCO TOKYO
HIMEJI WORKS : 840, CHIYODA CHO, HIMEJI, JAPAN

JY992D93201A

Effective JAN. 2001
Specifications are subject to change without notice