



ENGLISH

RANGE SERVANT[®]

<http://www.rangeservant.com>



USER'S MANUAL RS BALL DISPENSER

© Copyright, Range Servant
3000 Center Place - Suite 300 Norcross, GA 30093
Phone: (800) 878-8050 Fax: (770)448-8060

CONTENTS

1. 1 General information	- 3 -
1.1. Preface	- 3 -
1.2. Description	- 4 -
1.3.1 Ball Dispenser	- 4 -
1.3.2 Ball Management System	- 4 -
1.3. Identification	- 4 -
1.5 Technical specifications	- 5 -
2. Safety	6
2.1 General	6
2.3 Remaining risks	6
2.4 Authorised use	7
2.5 Unauthorised use	7
2.6 Emergencies	8
2.6.1 Fire	8
2.7 Operational reliability	8
3. How to use the Ball Dispenser	8
3.1 Necessary qualifications	8
3.2 BA-99 Control System	9
3.2.1 Introduction	9
3.2.2 Getting started	9
4. Design and function	10
4.1. General	10
4.1.1 Machine exterior	11
4.1.2 Machine interior	12
5. Maintenance	13
5.1. General	13
5.2. Maintenance intervals and instructions	13
5.3. Troubleshooting and repair	14
5.4. Function test	16

6. Installation	16
<hr/>	
6.1. Factory testing and configuration	16
6.2. Installation of the ball dispenser	17
Possible number of balls upon each payment	20
6.3. Installation – Wiring Diagram	21
6.3.1 Wiring Diagram for the connection of BA-99 to the Ball Dispenser	21
6.3.2 Wiring of Payment Systems	22
Token	22
6.3.2.6,6.3.3.2 Power supply	22
7. Spare parts	22
<hr/>	
7.1. External	24
7.1.1 External RS-4	24
7.1.2 External RS-8	25
7.1.3 External RS-12	26
7.1.4 External RS-20	27
7.1.5 External RS-45	28
7.2 Control box	29
7.2. Internal	30
7.3.1 Grid	31
7.3.2 Side view of grid inside the ball dispenser	31
7.3.3 Grid inside ball dispenser, viewed from above	32

Title:	RS Ball Dispenser Manual
Prepared by:	Daniel Yenerall
Date:	05-29-2008
Version:	052908

1.1 General information

1.1. Preface

We congratulate you to your new Range Servant machine. You have made a good choice! Not only have you chosen an excellent state-of-the-art Ball Dispenser with little demands on maintenance but you have also chosen quality. Quality is ensured with the help of modern production techniques, carefully chosen materials and the responsible workmanship of our staff.

This User's Manual contains all the information necessary to fully understand the maintenance and operation of the machine.

Study the User's Guide carefully before using the machine. If these instructions are not followed, persons using the machine might be injured or the equipment itself be damaged. In many cases, following the instructions is a necessary condition for Range Servants' warranty to be applicable. Every person operating the machine must read these instructions.

No part of this publication may be reproduced without the written authorisation of Range Servant.

We offer a limited one-year warranty on our Ball Dispensers. This does not include payment systems and normal wear and tear. Study the warranty conditions carefully and keep them in a safe place. If you have any questions, or if problems should arise, please contact your Range Servant representative.

ONE-YEAR WARRANTY

Range Servant AB hereby undertakes to provide a warranty on material and function on the RANGE SERVANT dispenser for one year from the date of delivery. The guarantee does not cover payment systems and wearing parts. This engagement applies to repaired or replaced components for a period of three months. This undertaking only applies to the original purchaser. It also applies only to shortcomings of those parts, which the manufacturer verifies after due inspection. Repairs or replacement of parts may only be carried out by a representative authorised by the manufacturer. The manufacturer also guarantees that the equipment delivered matches the product description supplied. **THE UNDERTAKINGS SPECIFIED IN THIS AGREEMENT CONSTITUTE THE MANUFACTURER'S SOLE OBLIGATION TOWARDS THE PURCHASER. THE MANUFACTURER IS IN NO WAY RESPONSIBLE FOR ANY UNDERTAKINGS OUTSIDE THE FRAMEWORK OF THIS WARRANTY CERTIFICATE.** Neither is the manufacturer responsible for any undertakings given by any outside person during the sales negotiations. The warranty agreement does not apply to equipment that has been repaired or replaced by persons/companies not authorised by the manufacturer. The manufacturer's warranty undertaking does not apply if the equipment is used incorrectly, if it has been damaged through improper maintenance or accidents or if it has been handled in a way not specified in the manual which is supplied with the dispenser upon delivery. The manufacturer is also free from financial liability for any type of injury that may arise in connection with the sale and repair of the equipment and from injuries to third parties in conjunction with its use.

1.2. Description

1.3.1 Ball Dispenser

The Ball Dispenser can be used either as a stand-alone machine or it can be integrated into a complete, automated system - the Range Servant Ball Management System.

The user-friendly ball dispensers from Range Servant are designed to accept different types of payment and to deliver, quickly and consistently, the exact number of balls. Prices are differentiated and several payment methods can be used in parallel. The number of dispensed balls per payment can be easily changed by the user himself. The balls are handled with care and only undamaged and clean balls are delivered to the player.

1.3.2 Ball Management System

Range Servant can deliver a complete, flexible Ball Management System adaptable to any kind of driving range requirements. The Ball Dispenser can be combined with the work-efficient, environment friendly Ball Washer. The Ball Washer in turn can be connected to the Elevator, the Conveyor Belt or the Blower for the transport of clean, undamaged balls from Washer to Dispenser. The system also includes a Ball Picker machine picking up used balls from all over the driving range. Thus the circle is closed and manual work reduced to a minimum.

By applying our extensive know-how to the specific problems of every driving range we are able to offer tailor-made solutions.

1.3. Identification

When contacting Range Servant, please identify your machine with the help of the information contained in the identification plate. The identification plate is well visible and firmly attached and contains the following information:

- Name and address of the manufacturer
- Designation of series or type of machine
- Serial no., if any
- Year of manufacture

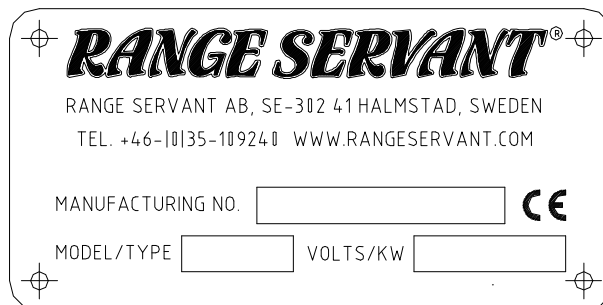

Fig. 1: Product identification plate

1.5 Technical specifications

General	RS-4	RS-8	RS-12*	RS-20*	RS-45*
Capacity [balls]	5 200	8 000	12 000	20 000	43 000
Settings [balls/turns]	9-17	9-17	9-17	9-17	9-17
Settings [turns/ payment]	1-999	1-999	1-999	1-999	1-999
Water connection	R 1/2"	R 1/2"	-	-	-
Min. water pressure [bar] /([psi])	1.96 (28.4)	1.96 (28.4)	-	-	-
Drain connection [mm] /([in])	75 (3)	75 (3)	-	-	-
Water consumption [L/turn] /([gal/turn])	0.5 (0.13)	0.5 (0.13)	-	-	-
Dimensions:					
Height [mm] /([in])	1476 (58.1)		2201 (86.7)		
Height with open lid [mm] /([in])	1950 (76.8)		-		
Width [mm] /([in])	1012 (39.8)			2022 (79.6)	
Depth [mm] /([in])	550 (21.7)	760 (29.9)		1520 (59.8)	
Weight, with balls [kg]		462	648	1112	XX
Weight, without balls [kg]	88	95	110	220	274
Electric system:					
Mains voltage (V, 60 Hz)	120	120	120	120	120
Control voltage (V, DC)	12	12	12	12	12
Effect, feeding motor (W)	70	70	70	2x70	2x70
Operating Conditions:					
Operating Temperature [°C] /([°F])	+2 - +50 (+35- +122)				

* Ball Washer and elevator not included

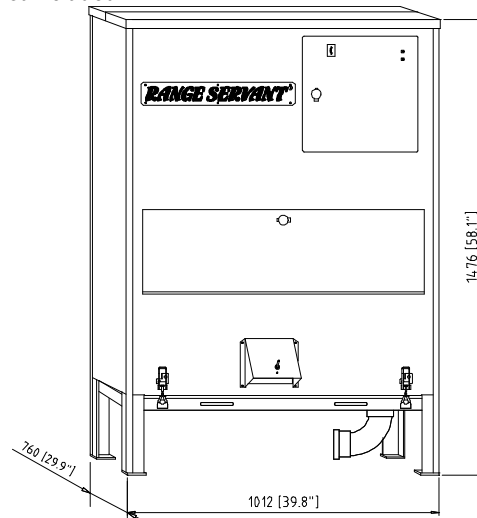

Figure 2: Ball Dispenser RS-8.

2. Safety

2.1 General

Safety measures are a combination of measures taken by the manufacturer when designing and building the machine and measures that have to be taken by the user.

The machine has been designed to function for its intended purpose. It has been designed and manufactured in such a way that configuration and maintenance can take place with the least possible risks to the operator, provided such work is carried out according to the instructions laid down in the User's Manual.

The objective of the safety measures is to eliminate all accident hazards during the operational life of the machine which also includes the assembly and dismantling of the machine, including any hazards arising as a consequence of such abnormal circumstances as can be anticipated.

Accessories and spare parts that have not been approved by Range Servant can lead to personal injuries and/or equipment damage and affect the operational reliability of the machine. For the sake of safety you should therefore exclusively use accessories and original Range Servant spare parts recommended by Range Servant.

Such accessories and spare parts are specially intended for the machine and are approved by us with regard to safety.

All Range Servant retailers keep accessories and spare parts at your disposal along with competent advice. They also have the technical qualifications necessary for installing your machine and are informed about what technical changes are authorised.

Damage caused by the use of accessories and spare parts not having been approved by Range Servant and damage due to unauthorised technical modifications are not covered by the warranty obligation.

2.3 Remaining risks

There are warning signs serving as a reminder and warning to the user of any remaining risks, i.e. risks that we have not been able to eliminate, or sufficiently minimise, in our design and against which technical safety measures do not provide complete, or sufficient, protection. The warning signs shall be written in the local language and, on request, in the language understood by the respective operator. The signs are yellow with black characters. They are big enough to be readable from a distance of three meters.



Fig. 3: Warning signs on front hatch

- Always disconnect the power supply to the machine before carrying out maintenance or service work. The mains switch is located in the control box in the lower right hand corner of the printed circuit board.



Fig. 4: Warning signs in control box

- Never touch the circuit board or other electrical components in the control box. They can be current conducting and cause injury to person and/or equipment damage
- Mechanical or electrical alterations may only be undertaken in consultation with Range Servant.

2.4 Authorised use

The ball-dispensing machine may only be used for the distribution of golf balls. For the machine to operate properly, the balls must be clean and undamaged or else they may get stuck and cause machine failure.

Distribution of balls may only start provided the machine has been installed according to the instructions contained in this Manual.

2.5 Unauthorised use

Using accessories or spare parts not recommended by Range Servant might cause personal injury and/or equipment damage and affect the operational reliability of your ball dispenser. For safety reasons, use only those components recommended by us. They are intended for your machine, they have been chosen for safety reasons and they are approved by the manufacturer.

Damage caused by the use of accessories and spare parts not having been approved by Range Servant or damage due to unauthorised technical changes are not covered by the warranty obligation.

2.6 Emergencies

2.6.1 Fire

Water shall be used as an extinguisher in the event of fire, except if the fire is located in the electric equipment, where a carbon dioxide extinguisher must be used.

2.7 Operational reliability

For trouble-free operation and long service life the instructions below should be followed:

- Place the ball-dispensing machine on a firm and level surface.
- Place the machine under cover so that only the front is accessible to members of the public. If the machine is card-operated it must stand under cover for the warranty to apply.
- Never strain the machine by loading it with more balls than recommended. The loading capacity for your machine is stated in the Technical Specifications at the end of the Manual.
- The machine should be connected to its own wall socket to prevent interference with its electronic system.
- Make sure that the electric box is always properly shut and covered when rinsing the machine. Moisture and water can damage the electrical components.
- When cleaning inside the dispenser never spray water directly onto the electric motor.
- By temperatures below 2°C the machine should be equipped with a warm air fan or, as the case may be, the water supply should be closed off, in order to avoid ice building up inside the ball dispenser.

3. How to use the Ball Dispenser

3.1 Necessary qualifications

Due to the complex design and operation of the machine the person carrying out service and maintenance work must have the necessary qualifications. He is required to have attended a training course, in the form of a comprehensive study of the User's Manual, followed by a written statement to the fact that he has well understood its contents.

If the person has to be absent from work for more than three months, training has to be repeated.

3.2 BA-99 Control System

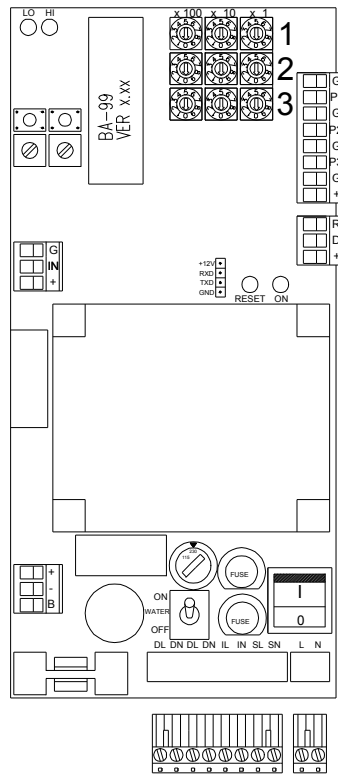

Fig. 5: BA-99 Control System

3.2.1 Introduction

The BA-99 system has three payment channels marked P1-P3 allowing the user to choose between three different amounts of balls to be dispensed ranging from 1-999. The desired amount is selected with the help of the nine knobs located to the left of the terminal block G – P1-P3. More details are given in the following chapter “Getting started”.

Payments can also be made during the dispensing process and will then be accumulated. A green LED marked ON is lit to indicate that power is on and a red LED marked DEP to indicate that payment has been registered and that the machine is prepared to dispense balls. The system is also equipped with a small circuit card consisting of two LED's , a green and a red one, giving continuous information to the user. Green LED indicates that mains supply is on and red that payment has been made and that machine is in the process of dispensing.

3.2.2 Getting started

The number of balls being delivered is determined by the number of turns made by the motor. With each turn of the motor a multiple of 9-17 balls is dispensed, see figure 25. You can decide yourself how many balls you wish the machine to dispense per payment as well as how many turns the machine shall make per payment. The Ball dispenser accepts different payment methods and you are free to decide whether the machine shall make the same number of turns for all the different payments methods or not.

Connect the Ball Dispenser to the 230 VAC mains supply.

Adjust the ball dispensing knobs for the respective payment channel according to wish. Make your payment and check that the motor makes the correct number of turns and that the correct number of balls are dispensed.

Example:

Payment channel 1

2 turns x 100 = 0
 x 10 = 2
 x 1 = 3

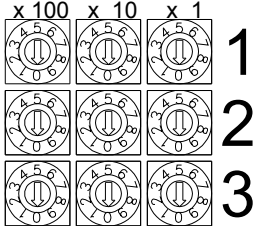

Payment channel 2

4 turns x 100 = 0
 x 10 = 5
 x 1 = 4

Payment channel 3

12 turns x 100 = 1
 x 10 = 2
 x 1 = 8

4. Design and function

4.1. General

The machine is intended for use as a golf ball dispenser. It consists of a ball magazine and is inside fitted with two plates on two levels for load reduction and, at the bottom, a grid.

The grid consists of a number of ball ducts, arranged next to each other, the ends being joined to form a hinged ball cradle. The depth of the cradle corresponds to the size of a golf ball. Thus, with each swing of the cradle only the number of balls inside the cradle are delivered to the ball chute.

All interior surfaces are inclined so that the balls are continuously flushed downwards. The lower level allows for damaged balls and debris to be sorted out.

All essential parts of the Ball Dispenser are manufactured of stainless steel, rust protected steel or aluminium.

The Range Servant Boll Dispenser has been designed in order to provide driving range owners with a long-lasting, reliable, practical and economic golf ball management system.

4.1.1 Machine exterior

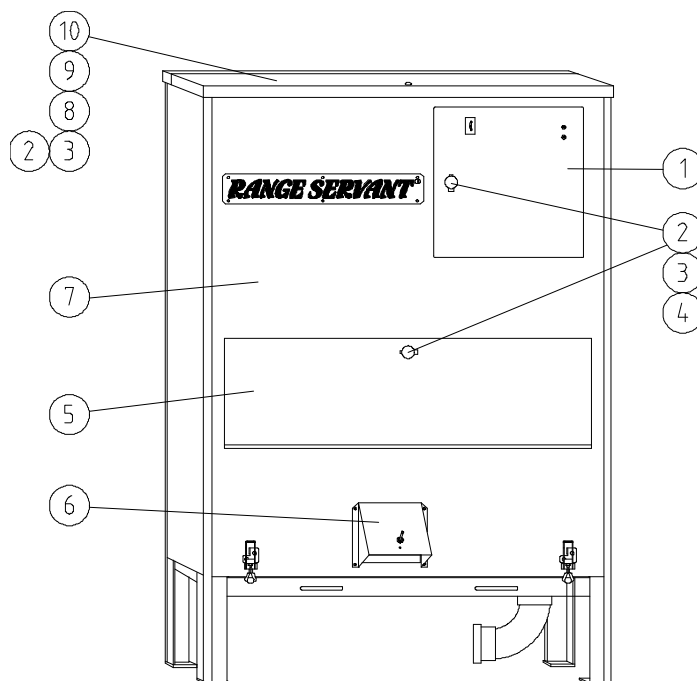

Fig. 6: Outside front view

Pos.	Designation
1	Control box door
2	Locks for control box, front hatch and lid
3	Shackle, front hatch lock and lid
4	Shackle, control box door
5	Front inspection hatch
6	Ball chute
7	Front panel
8	Front portion of lid
9	Lid hinges
10	Rear portion of lid

4.1.2 Machine interior

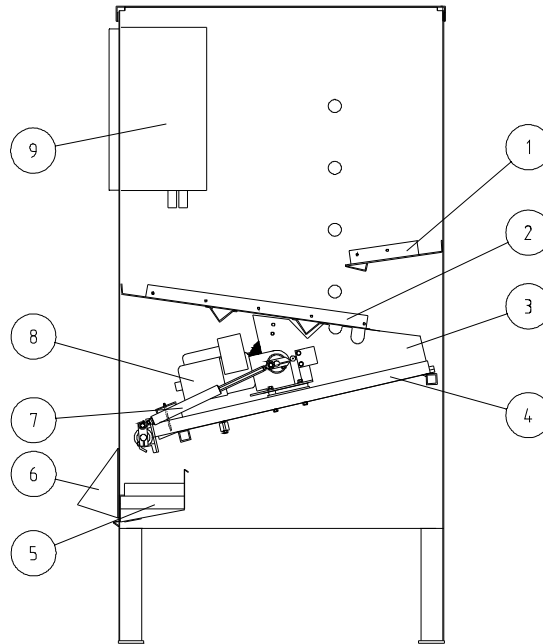

Fig. 7: Inside of the ball dispenser, side view

Pos.	Designation
1	Upper inclined plate
2	Lower inclined plate
3	Side plate of grid
4	Grid
5	Ball duct
6	Ball chute
7	Shock absorber
8	Dispenser motor
9	Control box

5. Maintenance

5.1. General

Maintenance carried out correctly minimises defects and ensures maximum service life and reliable operation. Any malfunctions are detected at an early stage and are therefore easily corrected. Regular maintenance minimises defects and equipment breakdown.

The following maintenance instructions only refer to the most common problems and their causes.

5.2. Maintenance intervals and instructions

Maintenance intervals:

1. After 300 operating hours
2. Once every month
3. Once every golf season

Maintenance intervals and instructions		1	2	3
1	Machine exterior			
1.1	Lubricate the eccentric lock, the lid and front hatch locks and the hinges of lid and front hatch with ordinary lubricating oil.		X	
1.2	Lubricate the eccentric lock, the lid and front hatch locks and the hinges of lid and front hatch with ordinary lubricating oil.			X
2	Machine interior:			
2.1	Tighten the fixation bolts of the grid.	X		
2.3	Lubricate the linking arms with ordinary lubricating oil.		X	
2.4	The collecting pan should be opened and cleaned regularly, to prevent grit and other debris from accumulating in the pan and gradually leading to corrosion and blockage.			X
2.5	If chemical fertilisers are used on the driving range, we recommend that the dispenser is cleaned thoroughly once a month to prevent corrosion of the machine's internal components. Cut the power supply to the machine, open the front hatch, remove grass and other debris and rinse with clean water.		X	
2.6	Empty the machine, sort out worn or damaged balls, stones and grit etc and clean the inside with normal clean water. (Do not spray water directly onto the electric motor.)			X
2.7	Clean and dry the ball duct (located after the grid).			X

5.3. Troubleshooting and repair

Although the operation of the machine is most reliable, problems may arise for various reasons.

Attention!

To reduce the time spent on troubleshooting, always start by checking that cables and connections are clean and tightened.

Symptoms	Possible fault	Corrective measures
The Ball dispenser does not start.	→ The power supply is not connected.	→ Connect the machine to the power supply.
	→ The ON/OFF switch on the circuit card is not "ON".	→ Set the switch in the "ON" position.
	→ Defective fuse(s) on the circuit card.	→ Replace the fuse(s) (2.5A/250V).
	→ Payment method is defective.	→ Check the voltage with Ohmmeter. The voltage should fall from 5VDC to 0VDC when active. All payment methods must be NO (Normally Open).
	→ One payment channel is active.	→ Measure the payment channel voltage and check that no channel is 0VDC.

Fig. 8: Problem - the Ball dispenser does not start.

The BA-99 control system requires at least one pulse from the micro-switch every ten seconds. Else the machine will make three quick starts and then close the feeding of balls.

Symptoms	Possible fault	Corrective measures
The Ball Dispenser does not stop.	→ The micro-switch no. 105500 is not in the correct position or is stuck in closed position.	→ Check that the micro-switch is correctly positioned and has not got jammed.
	→ The supply voltage to the machine varies.	→ Connect the machine to a separate wall socket.
	→ The magnetic coil no. 10540 is defective.	→ Check by disconnecting the automatic water feed. If the machine then works properly, replace the magnetic coil.

Figure 9: Problem - the ball dispenser does not stop.

Symptoms	Possible fault	Corrective measures
The machine is running but does not dispense any balls.	⇒ The machine is not standing on a level and firm surface.	⇒ Use a spirit level to check that the machine is level.
	⇒ The balls in the machine are dirty.	⇒ Empty the machine of balls. Clean the machine inside and rinse well. Fill the machine with clean balls - that have been run through the Range Servant washer.
	⇒ There may be ice build-up in Machine.	⇒ If ice has built up, disconnect the water supply so that the machine is emptied of water. Make sure the ice has melted before using the machine
	⇒ The ball cradle is jammed.	⇒ Open the front hatch and remove the object jamming the cradle.
	⇒ The shock absorber is defective.	⇒ Replace the shock absorber.
	⇒ The motor shaft is damaged.	⇒ Replace the motor.

Figure 10: Problem – no balls are delivered

Symptoms	Possible fault	Corrective measures
The balls are not rinsed with water.	⇒ The machine is not equipped with water feed.	⇒ Only models without the conical top are equipped with water feed (NOTE: not RS-4).
	⇒ The water supply has not been opened or it does not reach the machine.	⇒ Connect the water hose to the machine and open the supply.
	⇒ The switch marked "WATER" on the circuit card is not in the ON-position.	⇒ Set the switch to ON.
	⇒ The filter is clogged.	⇒ Clean or replace the filter.
	⇒ The holes in the sprinkler arm are clogged.	⇒ Clean or un-clog the holes with a drill.
	⇒ The magnetic coil no. 105400 is defective.	⇒ Replace the magnetic coil.

Figure 11: Problem – no rinsing water.

Symptoms	Possible defect	Corrective measures
The Ball Dispenser does not start.	<p>⇒ Token contacts do not close.</p>	<p>⇒ Check the voltage with Ohmmeter. The voltage should fall from 5VDC to 0VDC when active (=closed position). The token switch must be connected in the NO position (Normally Open).</p> <p>⇒ Check that the token cable is not damaged or has stuck.</p>
	<p>⇒ The (Mechanical) Coin Control switch does not close.</p>	<p>⇒ See above re. token switch.</p>
	<p>⇒ The coin output of Electronic Coin Control Cashflow 340 is not activated.</p>	<p>Activate coin output of Cashflow (acc. to 3.3.3.1 "Change of price, blocking of coins etc.").</p> <p>⇒ Measure payment channel with Ohmmeter. Voltage should fall from 5VDC to 0VDC when active. Check the price setting.</p>
	<p>⇒ The debits of the magnetic card reader EMC-30 do not appear in the display.</p>	<p>⇒ There are no dispenses left on the card. Try a new card.</p> <p>⇒ Check that resistor 33k Ohm is not defective.</p>
	<p>⇒ EMC-30 debit indications appear on the display but the displayed number does not change and dispensing does</p>	<p>⇒ Check that the mechanical switch of the reader unit is not closed.</p>

Figure 12: Problem – payment methods.

5.4. Function test

After maintenance or repair work the operation of the machine should be tested by running the machine with the front hatch open. Insert a coin/token or payment card and check that everything works to satisfaction.

6. Installation

6.1. Factory testing and configuration

The ball dispensers are always tested and configured before delivery to the customer. On this occasion all the parameters of the control system are adjusted according the customer's wishes.

Our objective when carrying out this final check is to verify that the product corresponds on all accounts to the requirements laid down by the customer when ordering and to prevent defective products from being brought onto the market.

6.2. Installation of the ball dispenser

For trouble free operation, place the ball dispenser on a firm and level surface.

We recommend that the machine be located under cover and that only the front of the machine be accessible to members of the public. If the machine is card-operated, it must stand under cover according to the terms of the warranty.

Place the ball dispenser on a firm and level surface.

Remove the keys tied to the electric cable (see A) and remove the cable.

ATTENTION! Don't plug in the cable before the machine is ready to start.

The keys are identical and are used for opening the control box (see B).

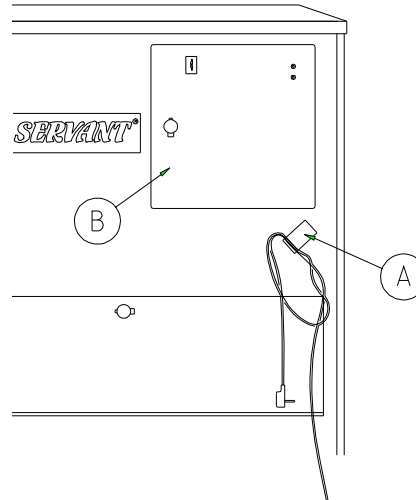

Figure 13: Location of the keys on delivery

Inside the control box there are another four keys, all identical, which fit the lid of the ball dispenser and the front inspection hatch.

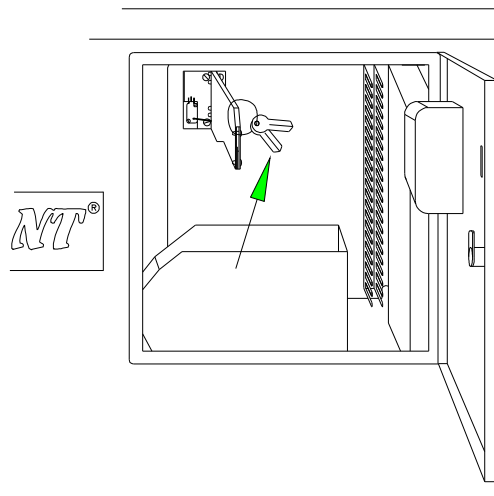

Figure 14: Location of keys in the control box.

Open the front inspection hatch and remove the package containing a plastic (PVC) pipe, a ball chute and the number of tokens you ordered for your machine.

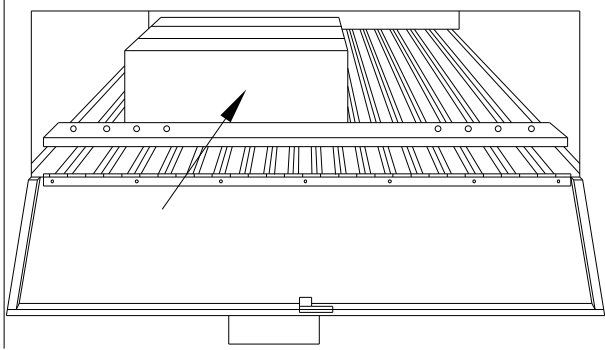

Fig. 15: Delivered material

Place the plastic tray inside the control box so that the tokens fall straight into the tray. If the machine is both token and coin operated, there will be two trays for sorting both forms of payment at source.

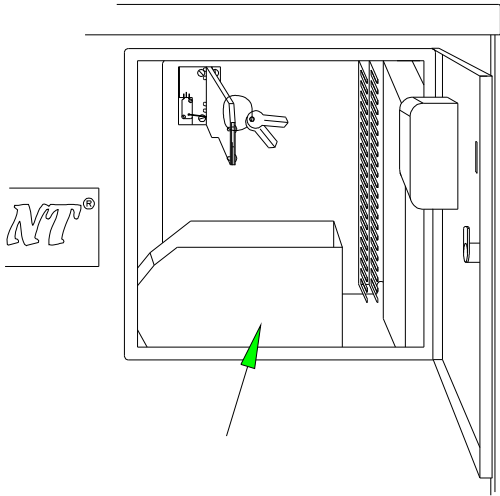

Fig. 16: Location of plastic tray.

Push the waste water pipe into place over the pipe at the rear right-hand side of the bottom plate and rotate it to face in the appropriate direction. Connect the curved pipe to your existing drainage system.

Use a 1/2" diameter hose to connect the water intake at the front right-hand side of the machine to a water tap, and turn the tap on full. The hose is not included with the machine.

ATTENTION! Don't plug in the cable before the machine is ready to start.

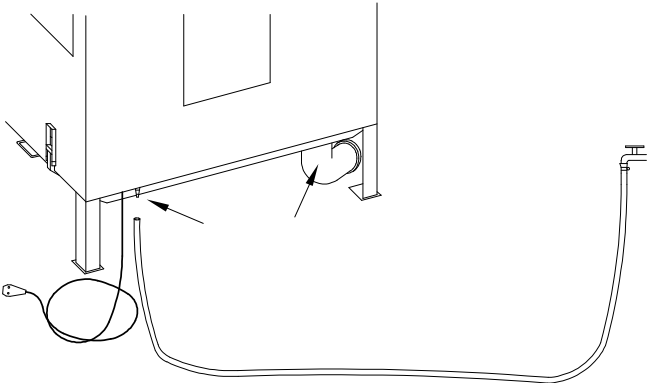

Fig. 17: Water and drain connection.

Screw the ball chute into place over the hole at the bottom front plate of the machine. Screw the top nuts through the holes. Then screw in the lower nuts from underneath after first opening the collecting tray.

Test a screw in each of the different holes on the front of the ball chute to find the best place to hang your ball buckets

Adjust the number of turns for the respective payment channels according to wish using the ball dispensing knobs as described in paragraph 3.2.2 "Getting started".

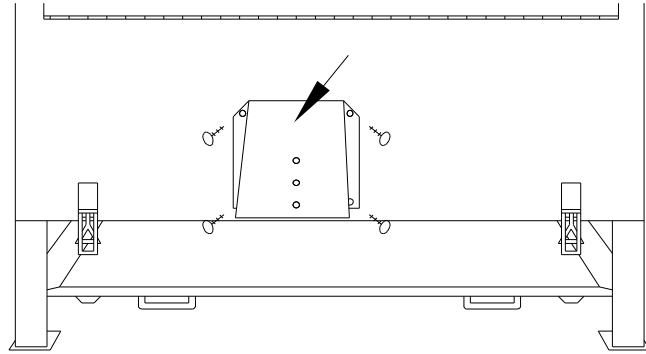

Fig: 18: Fastening the ball chute.

You are free to determine the number of balls to be dispensed upon each payment.

Block the number of ball ducts required to obtain the desired amount of balls to be delivered each time. This is done by adjusting the number of pins (A) along the horizontal retaining arm according to the adjoining drawing and place the enclosed plastic pipes (B) in the blocked ball ducts that is closed to the centre.

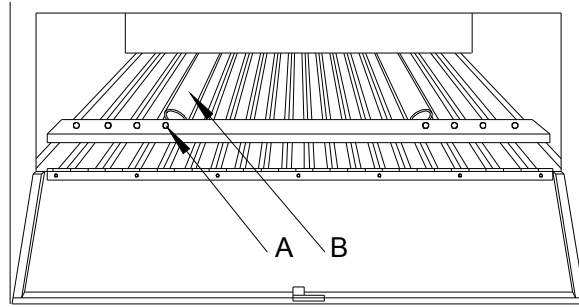

Fig. 19: Blocking of ball ducts

Below is a table helping you to find out how many balls may be dispensed upon each payment.

Possible number of balls upon each payment

Setting up number of balls on model RS-4/8/12/20/45

	1-turn	2- turn	3- turn	4- turn	5- turn	6- turn	7- turn	8- turn	9- turn
8 pins	9	18	27	35	45	54	63	72	81
7 pins	10	20	30	40	50	60	70	80	90
6 pins	11	22	33	44	55	66	77	88	99
5 pins	12	24	36	48	60	72	84	96	108
4 pins	13	26	39	52	65	78	91	104	117
3 pins	14	28	42	56	70	84	98	112	126
2 pins	15	30	45	60	75	90	105	120	135
1 pins	16	32	48	64	80	96	112	128	144
no pin	17	34	51	68	85	102	119	136	153

Fig. 20: Possible number of balls upon each payment

6.3. Installation – Wiring Diagram

To ensure safe and reliable operation, the control system must be correctly installed and grounded (earthed) and provided with good immunity against electronic noise.

6.3.1 Wiring Diagram for the connection of BA-99 to the Ball Dispenser

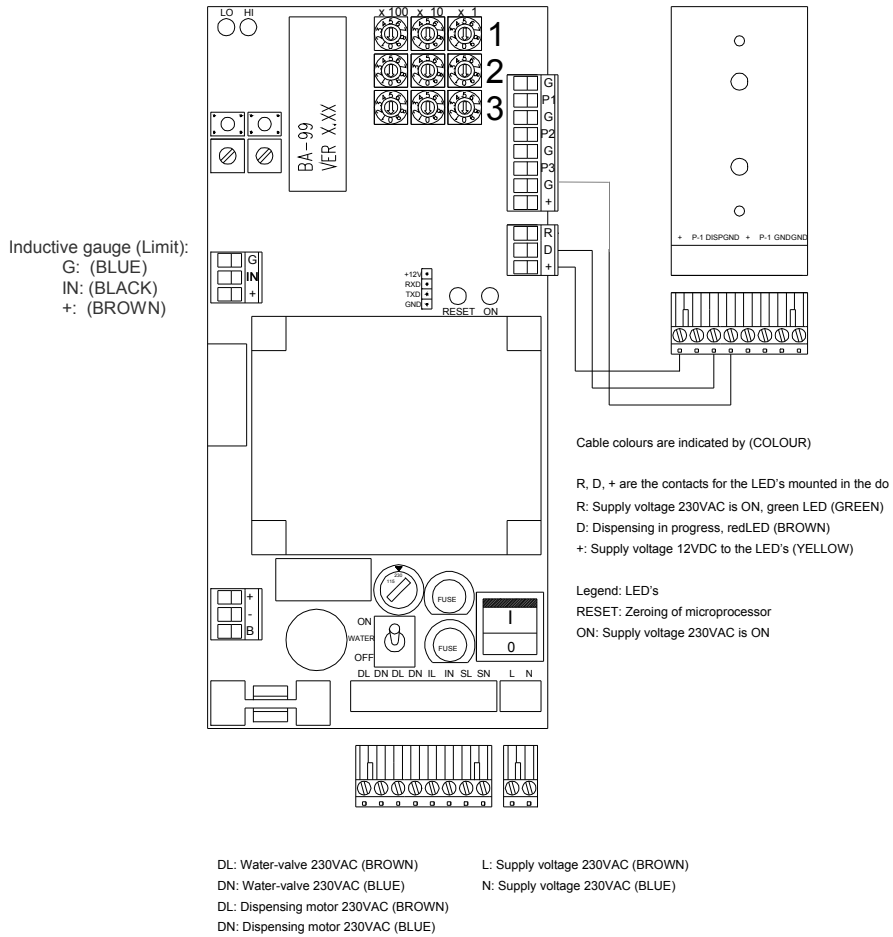

Figure 21: Wiring of the ball dispenser models RS-4, RS-8, RS-12, RS-18, RS-20, RS-45.

6.3.2 Wiring of Payment Systems

Token

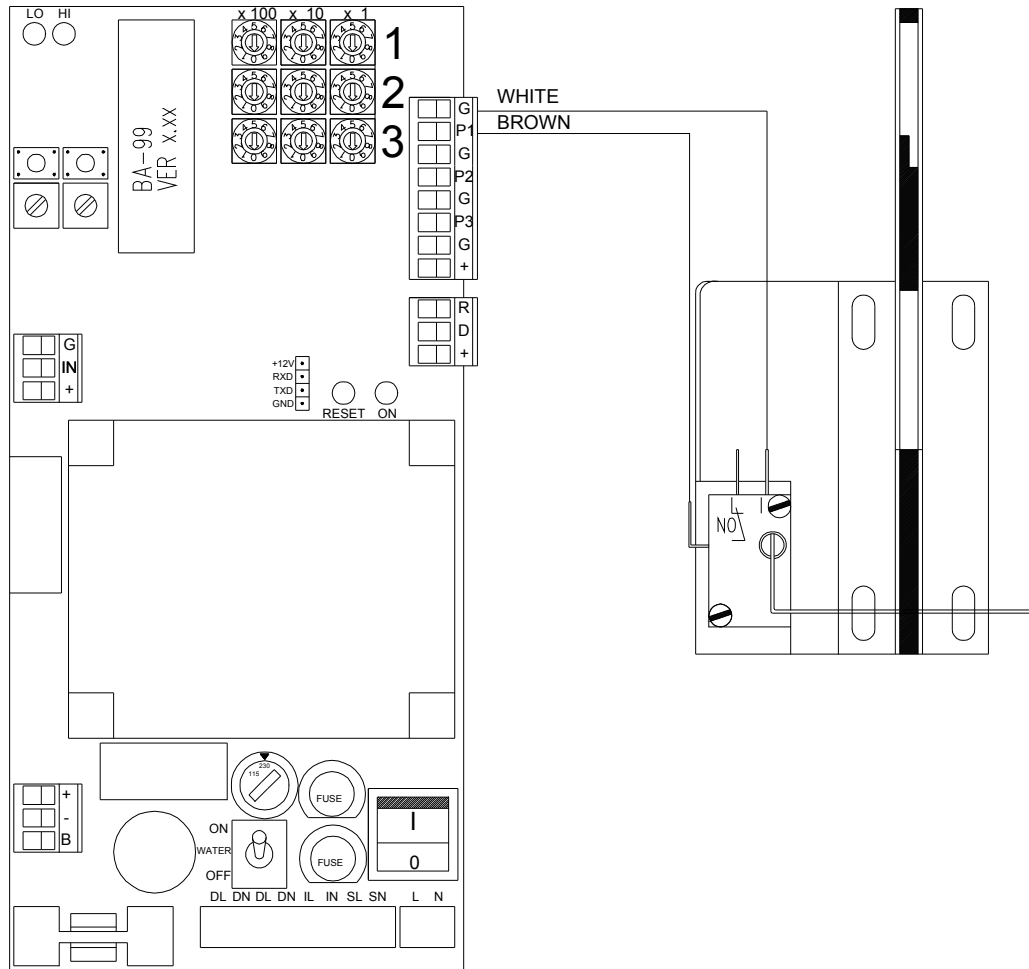

Figure 22: Wiring of the Range Servant Token Control.

The micro-switch for the token control must be connected as **NO** , Normally Open.

6.3.2.6 6.3.3.2 Power supply

All machines can be supplied with 230/115 VAC +/- 10% 50-60Hz.

7. Spare parts

In this chapter you will find detailed drawings of the ball dispenser showing the location of the different spare parts. The tables accompanying the drawings contain information about spare parts number and designation and the quantity of each spare part installed per machine model.

()= Optional accessories are marked with a parenthesis around the digit representing quantity.

- = The alternative marked with "-" depends on the customer's choice of equipment.

7.1. External

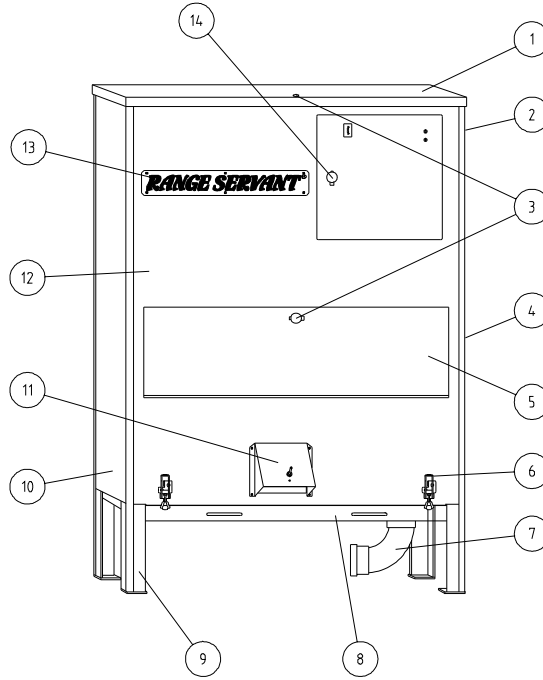

Figure 23: External RS-4

7.1.1 External RS-4

Pos.	Part No.	Designation	Quantity
1	186 600	Lid	1
	DJM0046	Lid hinges	2
	166 700	Lid retaining ribbon	1
2	150 500	Side panel, right	1
3	101 890	Pair of locks, with four keys	1
3	101 950	Straight Latch	2
4	151 101	Service hatch	1
5	101 800	Front hatch	1
6	102 100	Eccentric lock	2
7	• OAA 0001	Waste-water pipe	1
8	• 156 000	Collecting bowl	1
	156 011	Collecting tray	1
	DJM0047	Hinges, collecting tray	2
9	101 000	Legs	4
10	150 400	Side panel, left	1
11	102 000	Ball chute	1
12	181 500	Front panel	1
13	102 300	Sign, RANGE SERVANT	1
14	101 960	Bent Latch	1
	101 920	Spare key	1

• Ball Dispenser with water

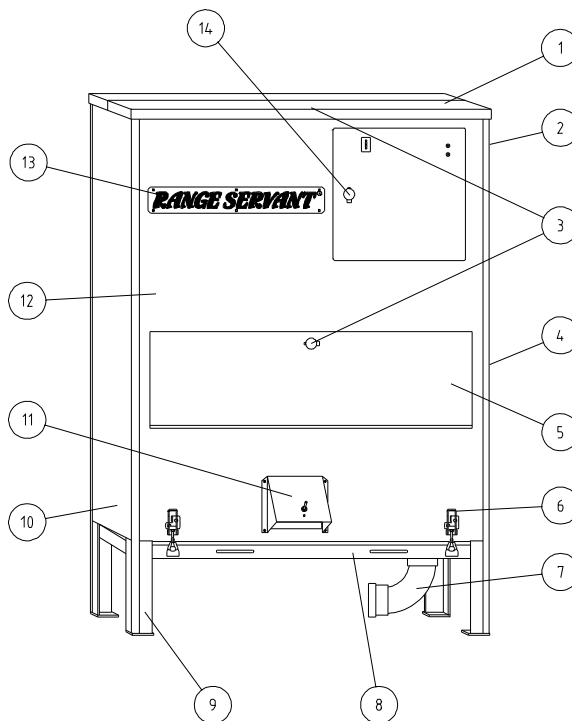

Figure 24: External RS-8

7.1.2 External RS-8

Pos.	Part N0	Designation	Quantity
1	186 600	Front portion of lid	1
1	186 500	Rear portion of lid	1
	DJM0046	Lid hinges	1
	166 700	Lid retaining ribbon	1
2	180 500	Side panel, right	1
3	101 890	Pair of locks with four keys	1
3	101 950	Straight latch	2
4	101 100	Service hatch	1
5	101 800	Front hatch	1
6	102 100	Eccentric lock	2
7	• OAA0001	Waste water pipe	1
8	• 186 000	Collecting bowl	1
9	101 000	Legs	4
10	180 400	Side panel, left	1
11	102 000	Ball chute	1
	186 010	Collecting tray	1
	DJM0047	Hinges, collecting tray	1
12	181 400	Front panel	1
13	102 300	Sign, RANGE SERVANT	1
14	101 960	Bent Latch	1
	101 920	Spare key	1

• Ball dispenser with water

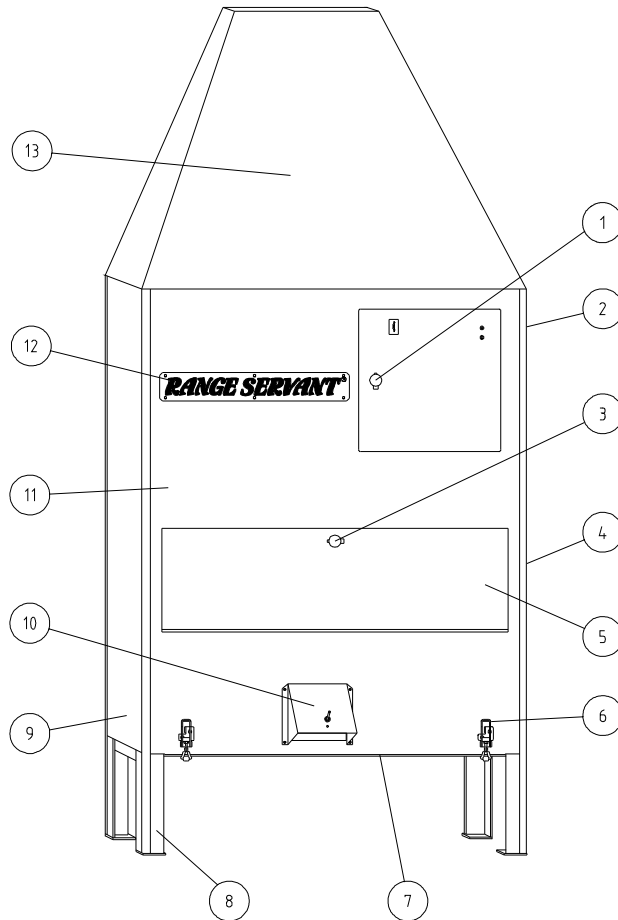

Figure 25: External RS-12

7.1.3 External RS-12

Pos.	Part No.	Designation	Quantity
1	101 900	Lock with two keys	2
1	101 960	Bent Latch	1
	101 920	Extra key	
2	180 500	Side panel, right	1
3	101 890	Pair of locks with four keys	
3	101 950	Straight Latch	1
4	101 100	Service hatch	1
5	101 800	Front hatch	1
6	102 100	Eccentric lock	2
7	186 010	Collecting tray	1
	DJM0047	Hinges, collecting tray	1
8	101 000	Legs	4
9	180 400	Side panel, left	1
10	102 000	Ball chute	1
11	181 400	Front panel	1
12	102 300	Sign, RANGE SERVANT	1
13	117 000	Top	1

• Ball dispenser with water

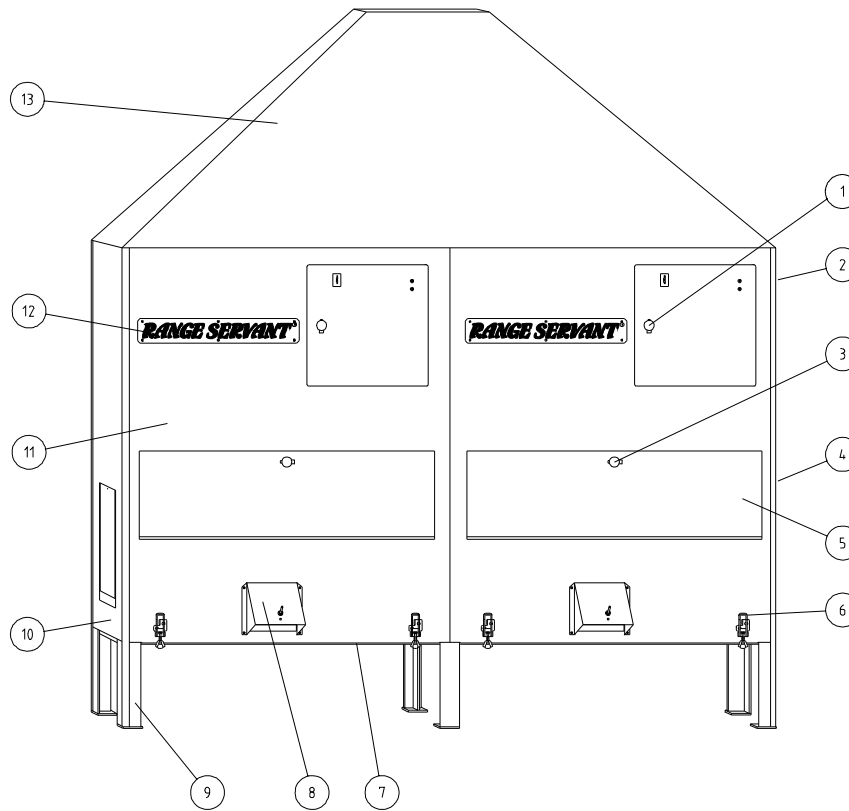

Figure 26: External RS-20

7.1.4 External RS-20

Pos.	Part No.	Designation	Quantity
1	101 900	Lock with two keys	2
1	101 960	Bent Latch	2
	101 920	Extra key	
2	120 500	Side panel, right	1
3	101 890	Pair of locks with four keys	
3	101 950	Straight Latch	2
4	101 100	Service hatch	2
5	101 800	Front hatch	2
6	102 100	Eccentric lock	4
7	186 010	Collecting tray	2
	DJM0047	Hinges, collecting tray	2
8	102 000	Ball chute	2
9	101 000	Legs	4
10	120 400	Side panel, left	1
11	121 400	Front panel	1
12	102 300	Sign, RANGE SERVANT	1
13	127 000	Top	1

• Ball dispenser with water

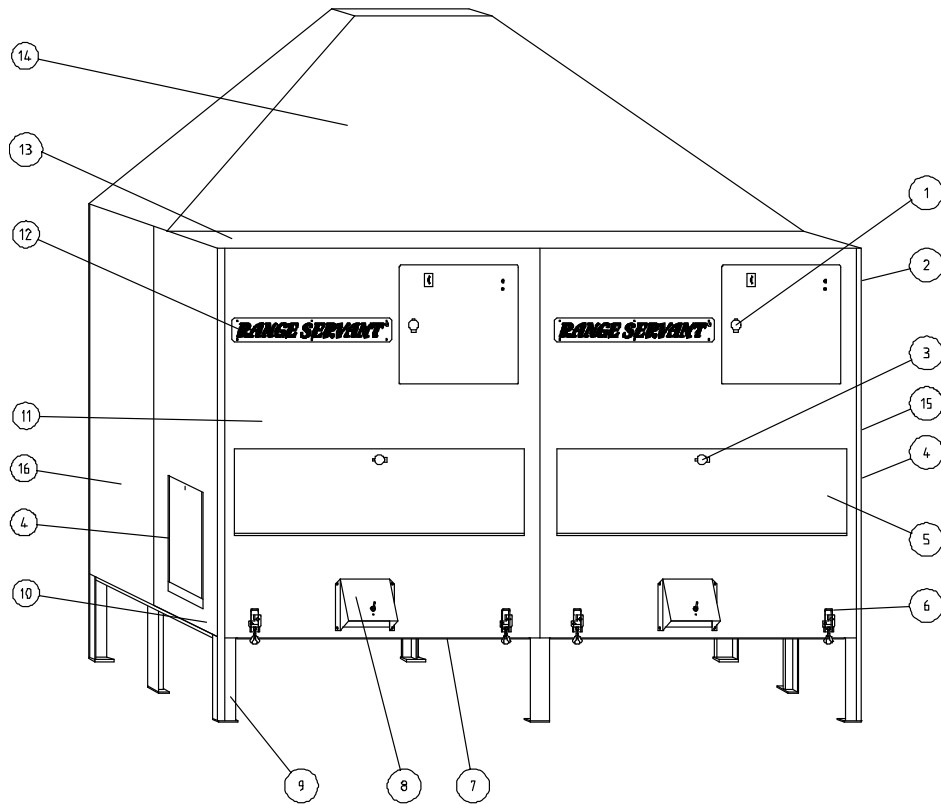

Figure 27: External RS-45

7.1.5 External RS-45

Pos.	Part Nr.	Designation	Quantity
1	101 900	Lock with two keys	2
1	101 960	Bent Latch	2
	101 920	Extra key	
2	120 500	Side panel, right	1
3	101 890	Pair of locks with four keys	
3	101 950	Straight Latch	1
4	101 100	Service hatch	2
5	101 800	Front hatch	2
6	102 100	Eccentric lock	4
7	186 010	Collecting tray	2
	DJM0047	Hinges, collecting tray	2
8	102 000	Ball chute	2
9	101 000	Legs	4
10	120 400	Side panel, left	1
11	121 400	Front panel	1
12	102 300	Sign, RANGE SERVANT	1
13	736 610	Lid	1
14	737 000	Top	1
15	720 500	Side panel, right	1
16	720 400	Side panel, left	1

7.2

Control box

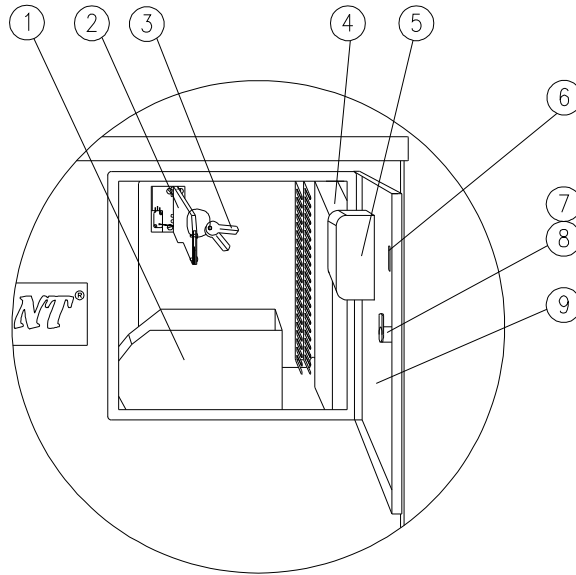

Fig. 28: Control box

Pos.	Part. No.	Designation	RS-4	RS-8/12	RS-20/45
1	109410	Token collecting tray, small	1	1	1
1	109400	Token collecting tray, large	(1)	(1)	(1)
2	108600	Token monitor	1	1	1
3	101920	Spare keys	-	-	-
4	930235	Printed circuit board BA-99	1	1	1
5	-	Coin monitor	-	-	-
6	-	Token slot	-	-	-
7	101900	Lock	1	1	1
8	101960	Bent Latch	1	1	1
9	-	Control box door	1	1	1

7.2. Internal

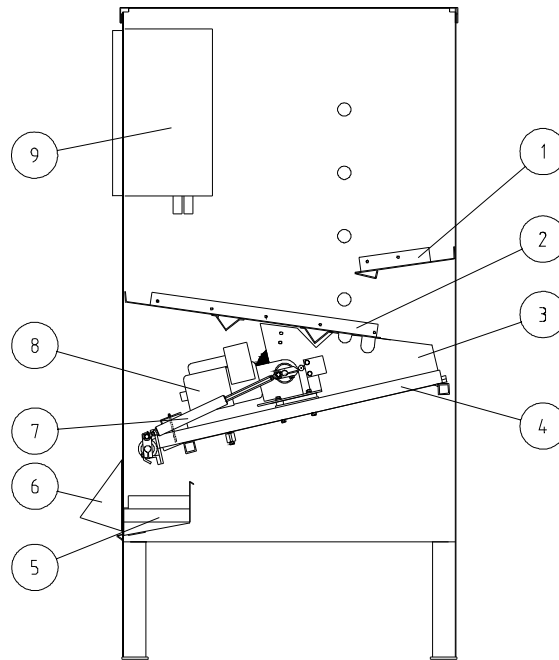

Figure 29: Cross section

Pos.	Part No.	Designation	RS-4	RS-8/12	RS-20/45*
1	102610	Upper inclined plate	1	1	1
2	152701	Lower inclined plate	1	-	-
2	102701	Lower inclined plate	-	1	1
3	154002	Side plate of grid	2	-	-
3	184002	Side plate of grid	-	2	2
4	153700	Grid	2	-	-
4	103700	Grid	-	2	2
5	183200	Ball duct	1	1	1
6	102000	Ball chute	1	1	1
7	104404	Shock absorber	1	1	1
8	105601	Dispensing motor	1	1	1
9	-	Control box	1	1	1

* Quantity per side

7.3.1 Grid

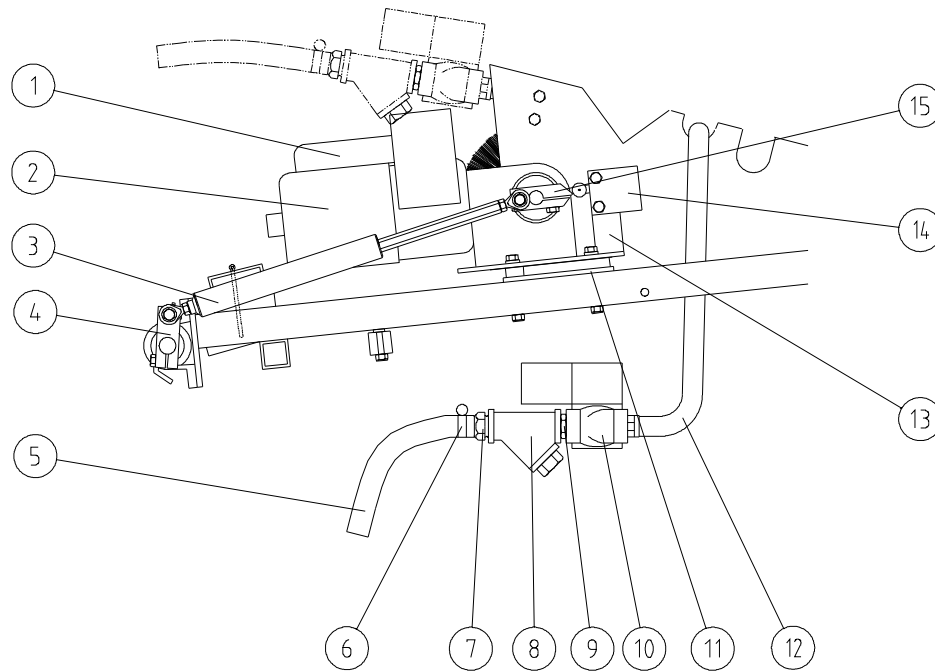

Figure 30: Grid viewed through the open front hatch

7.3.2 Side view of grid inside the ball dispenser

Pos.	Part No.	Designation	RS-4/8	RS-12	RS-20/45*
1	109 200	Capacitor 15 μ F	1	1	1
2	105 600	Motor 120V	1	1	1
3	184 400	Shock absorber	1	1	1
4	104 300	Lever	1	1	1
5	• 104 800	Water hose	1	-	-
6	• 104 900	Hose clamp	1	-	-
7	• 105 000	Hose nippel	1	-	-
8	• 105 100	Dirt sieve	1	-	-
9	• 105 200	Double nippel	1	-	-
10	• 105 300	Water valve 120V	1	-	-
11	DAM0002	Motor supporting plate	1	1	1
12	• 103 900	Sprinkler arm	1	-	-
13	104 700	Micro-switch holder	1	1	1
14	105 500	Micro-switch 14CE2-3	1	1	1
	125 500	Micro-switch, left	1	1	1
15	DAM0000	Eccentric with cam	1	1	1

• Ball dispenser with water

* quantity per side

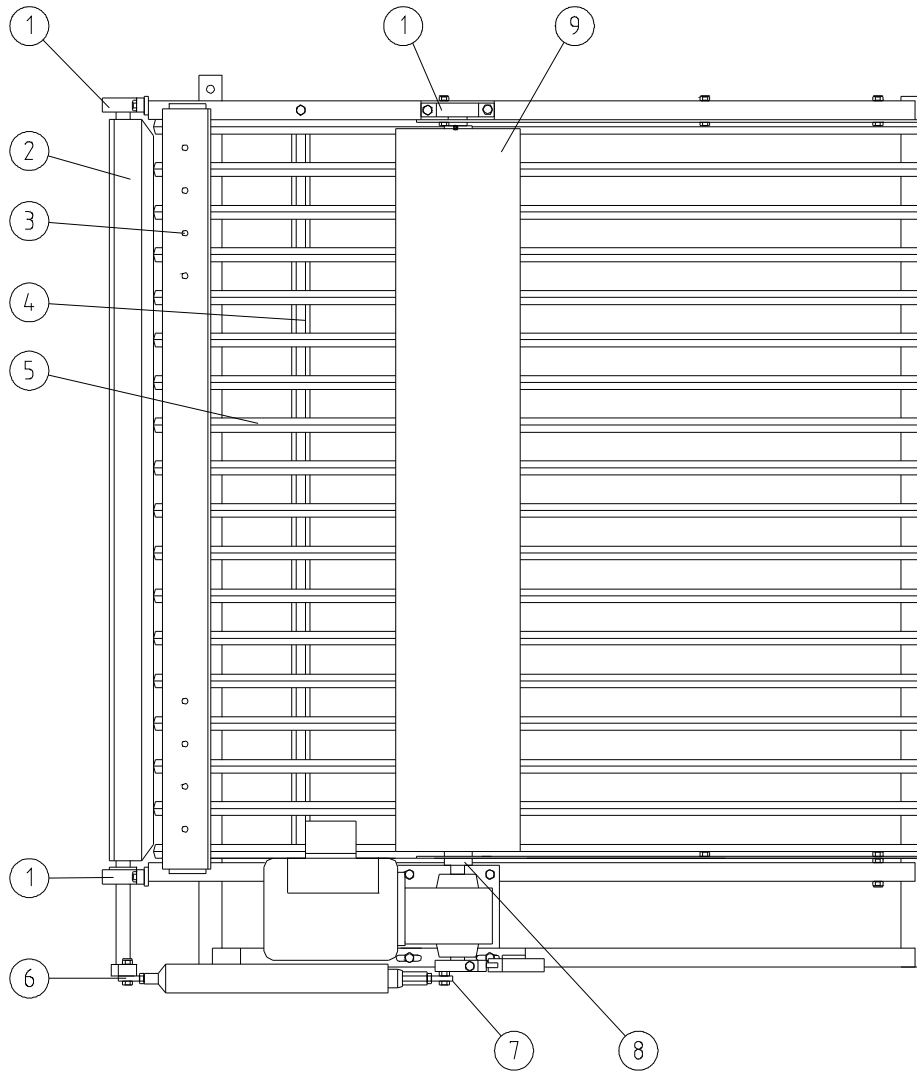

Figure 31: Grid viewed from above

7.3.3 Grid inside ball dispenser, viewed from above

Pos.	Part No.	Designation	RS-4	RS-8/12	RS-20/45*
1	104 650	Ball bearings	3	3	3
2	184 600	Ball cradle	1	1	1
3	51 000	6x65 cotter pins as end stops	8	8	8
4	• 183 800	Drip seal	1	-	-
5	183 700	Grid	-	1	1
5	153 700	Grid	1	-	-
76	104 510	Linking spindle, left-hand thread	1	1	1
87	104 500	Linking spindle, right-hand thread	1	1	1
8	104 130	Roller brush flange	1	1	1
9	184 100	Roller brush	1	1	1

- Ball dispenser with water
- quantity per side