

ACE II

Advanced Cryogenic Electronics

USER'S MANUAL



HP-307
October 2010

H **HOFFER FLOW CONTROLS, INC.**
PERFECTING MEASUREMENT

107 Kitty Hawk Lane, P.O. Box 2145, Elizabeth City, NC 27906-2145
800-628-4584 252-331-1997 FAX 252-331-2886
www.hofferflow.com E-mail: info@hofferflow.com

Notice

HOFFER FLOW CONTROLS, INC. MAKES NO WARRANTY OF ANY KIND WITH REGARD TO THIS MATERIAL, INCLUDING, BUT NOT LIMITED TO, THE IMPLIED WARRANTIES OF MERCHANTABILITY AND FITNESS FOR A PARTICULAR PURPOSE.

This manual has been provided as an aid in installing, connecting, calibrating, operating, and servicing this unit. Every precaution for accuracy has been taken in the preparation of this manual; however, HOFFER FLOW CONTROLS, INC. neither assumes responsibility for any omissions or errors that may appear nor assumes liability for any damages that may result from the use of the products in accordance with information contained in the manual.

HOFFER FLOW CONTROLS' policy is to provide a user manual for each item supplied. Therefore, all applicable user manuals should be examined before attempting to install or otherwise connect a number of related subsystems.

During installation, care must be taken to select the correct interconnecting wiring drawing. The choice of an incorrect connection drawing may result in damage to the system and/or one of the components.

Please review the complete model number of each item to be connected and locate the appropriate manual(s) and/or drawing(s). Identify all model numbers exactly before making any connections. A number of options and accessories may be added to the main instrument, which are not shown on the basic user wiring. Consult the appropriate option or accessory user manual before connecting it to the system. In many cases, a system wiring drawing is available and may be requested from HOFFER FLOW CONTROLS.

This document contains proprietary information, which is protected by copyright. All rights are reserved. No part of this document may be photocopied, reproduced, or translated to another language without the prior written consent of HOFFER FLOW CONTROLS, INC.

HOFFER FLOW CONTROLS' policy is to make running changes, not model changes, whenever an improvement is possible. This affords our customers the latest in technology and engineering. The information contained in this document is subject to change without notice.

RETURN REQUESTS / INQUIRIES

Direct all warranty and repair requests/inquiries to the Hoffer Flow Controls Customer Service Department, telephone number (252) 331-1997 or 1-800-628-4584. BEFORE RETURNING ANY PRODUCT(S) TO HOFFER FLOW CONTROLS, PURCHASER MUST OBTAIN A RETURNED MATERIAL AUTHORIZATION (RMA) NUMBER FROM HOFFER FLOW CONTROLS' CUSTOMER SERVICE DEPARTMENT (IN ORDER TO AVOID PROCESSING DELAYS). The assigned RMA number should then be marked on the outside of the return package and on any correspondence.

FOR **WARRANTY** RETURNS, please have the following information available BEFORE contacting HOFFER FLOW CONTROLS:

1. P.O. number under which the product was PURCHASED,
2. Model and serial number of the product under warranty, and
3. Repair instructions and/or specific problems relative to the product.

FOR **NON-WARRANTY** REPAIRS OR **CALIBRATIONS**, consult HOFFER FLOW CONTROLS for current repair/calibration charges. Have the following information available BEFORE contacting HOFFER FLOW CONTROLS:

1. P.O. number to cover the COST of the repair/calibration,
2. Model and serial number of the product, and
3. Repair instructions and/or specific problems relative to the product.

LIMITED WARRANTY

HOFFER FLOW CONTROLS, INC. ("HFC") warrants HFC's products ("goods") described in the specifications incorporated in this manual to be free from defects in material and workmanship under normal use and service, but only if such goods have been properly selected for the service intended, properly installed and properly operated and maintained. This warranty shall extend for a period of (1) year from the date of delivery to the original purchaser (or eighteen (18) months if the delivery to the original purchaser occurred outside the continental United States). This warranty is extended only to the original purchaser ("Purchaser"). *Purchaser's sole and exclusive remedy is the repair and/or replacement of nonconforming goods as provided in the following paragraphs.*

In the event Purchaser believes the goods are defective, the goods must be returned to HFC, transportation prepaid by Purchaser, within twelve (12) months after delivery of goods (or eighteen (18) months for goods delivered outside the continental United States) for inspection by HFC. If HFC's inspection determines that the workmanship or materials are defective, the goods will be either repaired or replaced, at HFC's sole determination, free of additional charge, and the goods will be returned, transportation paid by HFC, using the lowest cost transportation available.

Prior to returning the goods to HFC, Purchaser must obtain a Returned Material Authorization (RMA) Number from HFC's Customer Service Department within 30 days after discovery of a purported breach of warranty, but no later than the warranty period; otherwise, such claims shall be deemed waived. See the Return Requests/Inquiries Section of this manual.

If HFC's inspection reveals the goods are free of defects in material and workmanship or such inspection reveals the goods were improperly used, improperly installed, and/or improperly selected for service intended, HFC will notify the purchaser in writing and will deliver the goods back to purchaser upon (i) receipt of Purchaser's written instructions and (ii) the cost of transportation. If Purchaser does not respond within 30 days after notice from HFC, the goods will be disposed of in HFC's discretion.

HFC does not warrant these goods to meet the requirements of any safety code of any state, municipality, or any other jurisdiction, and purchaser assumes all risk and liability whatsoever resulting from the use thereof, whether used singly or in combination with other machines or apparatus.

This warranty shall not apply to any HFC goods or parts thereof, which have been repaired outside HFC's factory or altered in any way, or have been subject to misuse, negligence, or accident, or have not been operated in accordance with HFC's printed instructions or have been operated under conditions more severe than, or otherwise exceeding, those set forth in the specifications for such goods.

THIS WARRANTY IS EXPRESSLY IN LIEU OF ALL OTHER WARRANTIES, EXPRESSED OR IMPLIED, INCLUDING ANY IMPLIED WARRANTY OF MERCHANTABILITY OR FITNESS FOR A PARTICULAR PURPOSE. HFC SHALL NOT BE LIABLE FOR ANY LOSS OR DAMAGE RESULTING, DIRECTLY OR INDIRECTLY, FROM THE USE OF LOSS OF USE OF THE GOODS WITHOUT LIMITING THE GENERALITY OF THE FOREGOING, THIS EXCLUSION FROM LIABILITY EMBRACES THE PURCHASER'S EXPENSES FOR DOWNTIME, DAMAGES FOR WHICH THE PURCHASER MAY BE LIABLE TO OTHER PERSONS, DAMAGES TO PROPERTY, AND INJURY TO OR DEATH OF ANY PERSON. HFC NEITHER ASSUMES NOR AUTHORIZES ANY PERSON TO ASSUME FOR IT ANY OTHER LIABILITY IN CONNECTION WITH THE SALE OR USE OF HFC'S GOODS, AND THERE ARE NO AGREEMENTS OR WARRANTIES COLLATERAL TO OR AFFECTING THE AGREEMENT. *PURCHASER'S SOLE AND EXCLUSIVE REMEDY IS THE REPAIR AND/OR REPLACEMENT OF NONCONFORMING GOODS AS PROVIDED IN THE PRECEDING PARAGRAPHS. HFC SHALL NOT BE LIABLE FOR ANY OTHER DAMAGES WHATSOEVER INCLUDING INDIRECT, INCIDENTAL, OR CONSEQUENTIAL DAMAGES.*

Disclaimer:

Specifications are subject to change without notice.
Some pages are left intentionally blank.

Contents

Contents	i
Specifications	1
Overview	3
System Description	3
Front Panel	3
Model Number	5
Operation	7
Front Panel Operation	7
Display parameters	8
Contrast Adjust	8
Displaying Base Conditions	8
Displaying Software Version	8
Printing	8
Ticket Asterisks	9
Trip Report	9
Error Log	9
Audit Trail	9
Clearing	9
Auto Clear Feature	10
Error and Custom Messages	10
Passwords	10
Diagnostics	10
One-Minute Start Phase	10
Pump Interlock Option	10
Pump Service Timer	11
Pulse Security	11
CO ₂ Delivery	11
Net Accumulated Total	12
Programming	12
Reviewing Settings	13
Editing Program Settings	13
Menu Structure	15
Program Menu	16
Menu Fields	19
1. I/O Configuration	21
2. System Configuration	23
3. Channel Configuration	26
4. Meter Configuration	27
ACEII / PROVER Users	29

Diagnostics	31
Diagnostics Menu	31
Coil Resistance	31
RTD/ Analog Input	31
Analog Output.....	32
Digital I/O	33
Pulse Output.....	34
Heater Sensor	34
Base Conditions	34
Communications	35
Function Code 04 (Read Input Registers).....	35
Function Code 01 (Coil Status)	35
Installation	37
Location of the ACE II	37
Cable Installation	37
ACE II Program Setup	37
Printer Installation.....	37
WinConfig Program	39
Installation	39
Startup.....	39
Print.....	40
Configuration	40
I/O Configuration Menu	40
Pump Interlock Option.....	41
Meter Configuration Menu	42
Channel Configuration Menu	43
System Configuration Menu	44
Print Menu	45
ACE Menu	46
Downloading the Configuration	47
Configuration Files	47
Saving Configuration Files	47
Opening Configuration Files	47
Appendix A: Liquid Calculation Flow Chart	49
Appendix B: Units Of Measure	50
Appendix C: Error Messages	53
Appendix D: Reference Densities	54
Appendix E: Changing the Display Language	55
Appendix F: Drawings	56

Specifications

Environmental

Operating Temperature: -20°C to 70°C
-30°C to 70°C with optional heater
Storage Temperature: -40°C to 85°C
Humidity: 0-95% Non-condensing

Approvals and Regulatory Compliance

State of California Department of Weights and Measures
Standards:

AGA 7
OIML Tc 8 Sc 7, R117, R118
ISO 6551, 7637
NIST Handbook 44, 3.37

CE

Emissions EN55011

Im

munity EN61326

Enclosure

NEMA 4X
Optional Explosion Proof,

Power Supply

8 to 30 Volts DC, 400mA max
Optional 110/220 VAC, 50/60Hz, 250/500 mA

Display

128x64 graphical display
Easy scroll through list of up to 14 selectable process parameters
LED back light
Adjustable contrast

Keypad

3 soft keys + 2 arrow keys can be individually disabled

Optional Infra-Red Interface

Front panel infrared transmitter/receiver for remote operation and communication

Diagnostics

Multiple error messages
Failure detection for RTD and analog inputs
System configuration and diagnostics from a PC computer through RS-232 or IR port

Flow Compensation and Calculation Methods

5-point flow meter linearization
Up to 4 fluid properties tables

Security Features

Audit Trail with Time/Date/ID/New value/Old value for configuration changes

Flow Meter Input

Magnetic coil
Frequency range: 0.2 to 5,000 Hz.
Amplitude: 10mVrms to 50Vrms

Temperature Input

RTD selectable 100, 1000, 2500 Ohms
Accuracy 0.025%
Resolution 12 bit
Over voltage and over current protected

Analog Output

12 bit true D/A
Selectable 4-20mA, 1-5V

Pump Interlock Relay

240 Vac, 5A max.

RS232 Port

Printing or communication with a personal computer

Pressure Input

12 bit resolution
Selectable 4-20mA, 1-5V

Pulse Output

200 Hz max scaled to volume or mass units
0-5 V TTL, Open collector 30 Vdc, 250 mA max.

Clear Output

500mS pulse out
0-5 V TTL, Open collector 30 Vdc, 250 mA max.

Pulse Security Input

Quadrature input for magnetic coil, ISO6551 level B compliant
Frequency range: 0.2 to 5,000 Hz.
Amplitude: 10mVrms to 50Vrms

Overview

System Description

The ACE II, Advanced Cryogenic Electronics, is a truck mounted flow metering system for delivery of cryogenic fluids. The system uses an internal computer to record and display deliveries in the required units. An optional printer allows the system to print delivery information and ACE II setup parameters. ACE has been designed to meet the requirements of the cryogenic metering section of NIST HANDBOOK 44 and OIML R-81. Typical ACE II system consists of a turbine flowmeter, flow computer, a metering run mounted on the delivery truck, and an optional printer.

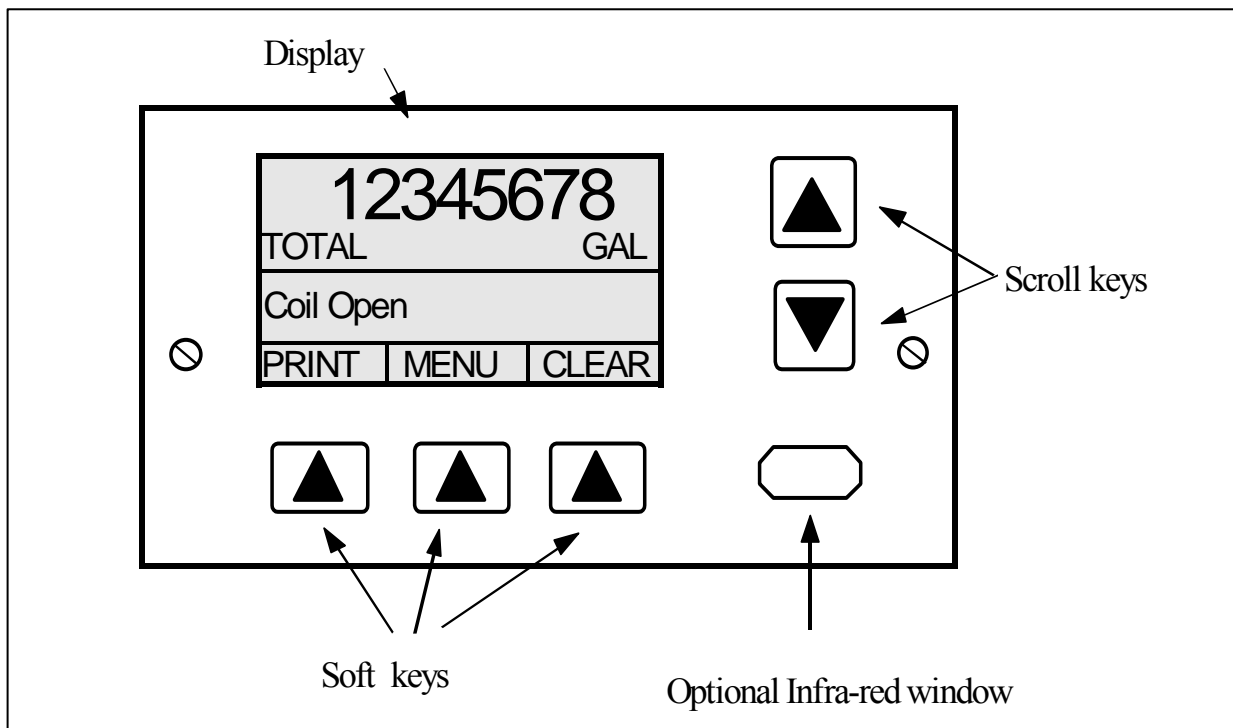

ACE II Front Panel

Front Panel

The ACE II flow computer has a graphical display with 64x128 pixel resolution. The display is divided into three sections: the upper section displays delivery total and other delivery parameters, the center section displays error and custom messages, and the lower section displays labels for the three software-controlled keys (soft-keys).

Below the display are three soft-keys, which functions vary with the ACE II mode of operation. The soft-key labels, which are displayed above the keys, change according to the key's function. On the right side of the display are the Up and Down SCROLL keys. These keys are used to select display parameters, and to navigate through the configuration menu. Under the SCROLL keys is an infrared window for communicating with a computer equipped with a compatible Serial to IR adapter or for printing to a model P7 printer.

This page intentionally left blank.

Model Number

The ACE II model number is provided by the Hoffer sales department based on the type of flow meter pick up coils, hardware options installed, power supply, enclosure type, and accessories supplied with a unit.

ACEII-(1T)-(P)-(Z)-(PS)-(12)-(H)-(S)-(SP)

SERVICE

Volumetric Products

- (1) LIN/ LOX/LAR
- (2) CO2
- (3) Nitrous Oxide
- (4) Liquid Hydrogen
- (5) LPG
- (6) LNG
- (7) (LIN/LNG/Ethylene
- (V) Volumetric
- (X) None

Temperature/Pressure

Compensation and RTD inputs

- (T) Add **T** after the number of the above product for temperature compensation
- (P) Add **P** after the number of all the products for pressure compensation
- (TP) Add **TP** after the number of products for both temperature and pressure

PUMP INTERLOCK

- (PI) 240 VAC, IMAX 5 AMPS
- (X) None

OUTPUT OPTION

Scaled Pulse or Analog Output

- (1) Open Collector
- (2) TTL/CMOS
- (7) 4-20mA output
- (8) 1-5Vdc output
- (X) None

SPECIAL FEATURES

- (SP) Any special features that are not covered in the model number
- (W) Windows, based RS-232 serial port configuration program with adapter and cable

ENCLOSURE STYLE

- (S) Standard-flat mount with shocks
- (T) Tilt bracket with shocks
- (E) Explosion-Proof with 5 switches on cover

HEATERS OPTIONAL

- (H) Heater required for below 32°F
- (X) No heater required

POWER INPUT

- (12) 12Vdc power input, 12 Vdc battery input
- (24) 24Vdc power input, 24 Vdc battery input
- (AC) 110/220 VAC input, 24Vdc power output

PULSE SECURITY INPUT

(PTB) OPTIONAL

- (PS) Quadrature Input per ISO6551 level B complaint (requires second mag coil on turbine)
- (X) None

This page intentionally left blank.

Operation

NOTE: This section applies only to ACE II units that have already been programmed. For initial programming and set up refer to the Menu Structure section of this manual.

Front Panel Operation

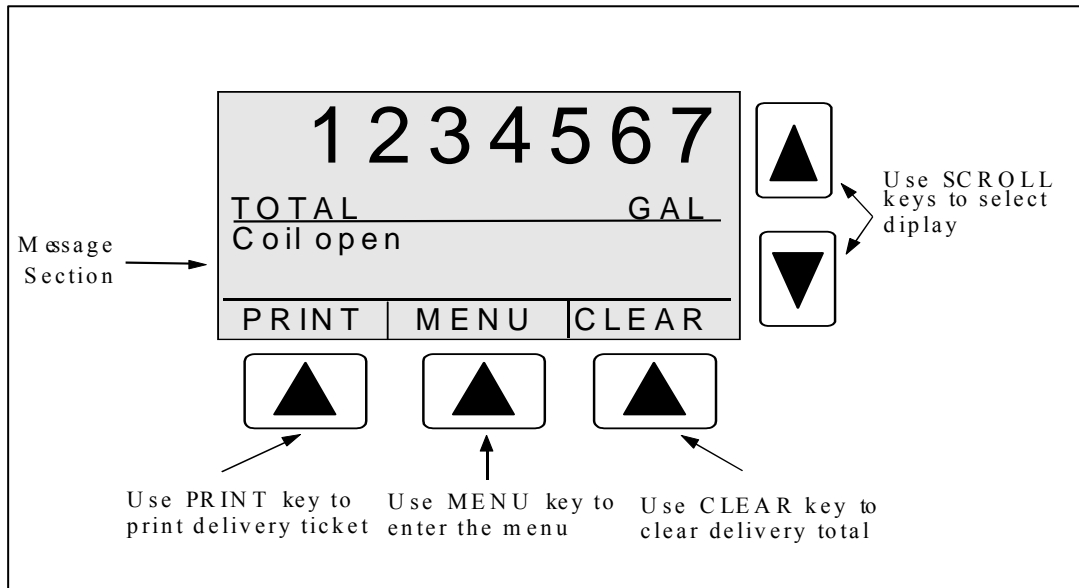

Display parameters

The following process parameters are available for display and may be selected using the Windows Configuration Program. Refer to the chapter on the WinConfig Program for more information on setting the display parameters.

Parameter Display		Description
Frequency	FREQ	Measured input frequency from turbine meter.
V/Rate	RATE	Flow rate, compensated to a selected reference condition, expressed in units of volume.
U/Rate	U/RATE	Uncompensated flow rate, expressed in units of volume.
V/Total	TOTAL	Compensated total, corrected to a selected reference condition, expressed in units of volume. ACEII always defaults to the total selected in Delivery Units.
U/Total	U/TOTAL	Uncompensated total, expressed in units of volume.
M/Rate	RATE	Compensated flow rate based on fluid density, expressed in units of mass.
M/Total	TOTAL	Compensated total based on fluid density, expressed in units of mass. ACEII always defaults to the total selected in Delivery Units.
M/Acc Total	ACTOT	Accumulated compensated total expressed in units of mass.
V/Acc Total	ACTOT	Accumulated compensated total expressed in units of volume.
U/Acc Total	U/ACTOT	Accumulated uncompensated total, expressed in units of volume.
Temp	TEMP	Measured flowing temperature. It will display a programmed default temperature when default temperature is being used for compensation, or "N/A" when temperature is not selected for compensation.
Press PRES		Measured flowing pressure. It will display a programmed default pressure whenever the default pressure is being used for calculation, or "N/A" when pressure is not selected for compensation.
Dens DENS		Measured flowing density. It will display a programmed default density whenever the default density is being used for calculation, or "N/A" when density is not selected for compensation.
Date and time	DATE	Current Date and Time

Contrast Adjust

Display contrast can be adjusted using the SCROLL keys during the first 15 seconds after power up. A message is displayed while the adjustment period is active. After the contrast adjustment period, the SCROLL keys are used to select display parameters or to navigate in the program menu.

Displaying Base Conditions

To display current Base/Reference Conditions press MENU key, scroll to item number 5 (Base Conditions) using the SCROLL key, and then press SELECT key.

Displaying Software Version

The software version number is displayed each time the ACE II is powered up.

Printing

Press the PRINT key to print a delivery ticket. A message will be displayed to ready printer. Press OK to print delivery ticket. To select other items for printing press the MORE key. Select a desired item for printing using SCROLL keys, and press the SELECT key. The printing function is available while flow is present.

ACE II detects when the printer is not connected, off line, or out of paper and displays a warning message.

Print Menu:

- Ticket
- Trip report
- Error Log
- Configuration data
- Audit Trail

NOTE: To print to a Model P7 printer via the IR port, Print Enable must be set to Infrared in the Utility Functions Menu.

Ticket Asterisks

Asterisks enclose the delivery total on all valid delivery tickets. If the feature is turned on, asterisks will be removed from the delivery ticket if any of the selected errors occur during the delivery, and exceeds the set accumulated error time. The errors can be viewed and selected in the Program / System Configuration / Utility Functions menu and the ACE menu in the WinConfig program. Asterisks are always removed when the delivery total does not reach the Minimum Delivery for a given meter size.

Trip Report

Trip Report registers stores up to 100 trip reports containing delivery information, and may be selected from the Print menu.

Error Log

Error conditions are recorded in the error log. The error log can be printed; it cannot be viewed on the display.

Audit Trail

Audit Trail records changes made to ACE II that affect the Delivery Total. Each record consists of sequential number, date, time, user ID, description of the field being changed, old value, and new value. The Audit Trail stores up to 1000 records. The records of the audit trail can be printed. A message prompts user to enter the number of records to be printed.

Clearing

To clear a delivery total press the CLEAR key. A message "Are you sure" will be displayed. Press YES key to confirm clearing. After pressing the YES key to confirm, information stored in the register will be lost. Press MORE key to select additional items for clearing.

Clear Menu: Total
Accumulated Total
Trip #

Clearing is not available while flow is present. A warning message will be displayed when the CLEAR key is pressed while flow is present.

Auto Clear Feature

After printing a delivery ticket, ACE II automatically clears the delivery total when the next delivery begins. Auto Clear feature is always active.

Error and Custom Messages

There are a number of warnings and error messages that guide the user in the event of an operational problem or conflict in the configuration parameters. When error conditions occur an error message is displayed in the message section of the display. If more than two error conditions occur simultaneously, the messages automatically scroll every three seconds. Refer to Appendix D for a list of error messages.

The message section can be used to display custom messages including fluid name, base conditions, compensation range. For further information on composing custom messages refer to the WinConfig section of this manual. A custom message is replaced by an error message when error conditions occur.

Errors are recorded in the ACE II error log for future printing.

Passwords

The ACE II has two levels of password protection: operator and supervisor. At each level there are five user ID numbers available. Any configuration parameter that may affect the flow calculation is protected with the supervisor password. Operator password allows clearing of Accumulated totals only. The unit is shipped unprotected, with all passwords set at 0000.

Diagnostics

To enter the diagnostic mode press MENU key, and select DIAGNOSTICS. Refer to Diagnostics section of this manual for further information about the diagnostics functions.

One-Minute Start Phase

During the first minute of operation, errors are displayed but are not recorded in the error log. This One-Minute Start Phase begins with the first indication that flow is present.

Pump Interlock Option

Pump Interlock is an optional feature that disables the pump when gas phase is detected in the meter run.

ACE II uses a Pump Cool Down Timer and Gas Detection feature to enable or disable the Pump Relay. If the Pump Interlock Option is selected, the temperature must drop below the Temperature Setpoint and liquid must be present at the pump before the relay will be enabled. When using default temperature method, the value assigned as the default temperature must be below the Temperature Setpoint for cool down to begin.

When the operating temperature drops below the programmed Setpoint value and liquid is detected, the Pump Cooling Timer is displayed in the Message Window which indicates "Pump Cooling Down *mm : ss*". This timer counts down from the programmed Delay Time value, enabling the Pump Relay when reaching zero. ACEII will not totalize and errors will not be recorded until the temperature has dropped below the Setpoint and the Pump Cooling Timer has reached 0. A Delay Time value of 0 disables the Pump Cooling Timer.

If at any time during the process gas is detected, the pump will be inhibited. This also applies to the One-Minute Start Phase. After the phase condition returns to a liquid state, ACE II will enable the Pump Interlock Relay.

There is a list of errors available to be selected for Pump Deactivation. The Pump relay is inhibited if selected errors exceed the programmed accumulated error time. The Accumulated Error Timer does not begin until the One-Minute Start Phase has concluded. The errors are as follows:

- Min Flow Error (50% of Min Flow Limit)
- Max Flow Error
- Pressure Signal Lost
- Gas Inhibit
- Compensation Range Error
- Probe Short Error
- Probe Open Error
- Coil Short Error
- Coil Open Error

Pump Service Timer

The pump service timer feature is designed to help with pump preventive maintenance schedule. When pump is serviced or installed the user enters the service date, the type of service and the maximum number of pump operational hours before the next service. ACE II will accumulate and display the total number of actual pump operational hours. If the number of operational hours exceeds the set number of Max Operate Hours an error message will be displayed. The error message will stay on until the actual hours display is reset to zero.

Pulse Security

ACEII provides an ISO6551 level B compliant quadrature input for pulse security. Error Detect must be turned on in the FLOWMETER Menu under I/O CONFIGURATION for pulse security to be active. "Pulse Frequency Error" will be displayed when an irregularity is detected on the input signal.

A dedicated input register is provided to count missing or double pulses deemed as "bad pulses". The % of Total During Error field in the UTILITY FUNCTIONS menu under SYSTEM CONFIGURATION is used to set the maximum allowable error based on a percentage of the delivery total. If this limit is exceeded at anytime during the delivery, "Bad Pulse Limit Exceeded" will be displayed in the message window. If the message is displayed at the end of the delivery, the error will be reported in the error log and ticket asterisks will be removed from the delivery ticket if this feature has been enabled. If the pump interlock option is enabled, "bad pulses" are not counted until the temperature has dropped below the Temperature Setpoint and the Pump Cooling Timer has reached 0.

CO₂ Delivery

ACE II systems specified for CO₂ service are equipped with a CO₂ Single Pipe Fluid table and CO₂ Dual Pipe Fluid table. The following describes in what manner each should be used.

SINGLE PIPE: The SINGLE hose delivery counts all product delivered through the meter on the totalizer. No correction is made for a vapor return or vapor balance line.

DUAL PIPE: A DUAL hose delivery occurs when a vapor return or vapor balance line is used in conjunction with the liquid delivery line. When the DUAL pipe method is selected, the totalizer automatically deducts the displaced vapor from the delivered total.

Net Accumulated Total

The net accumulated total is a difference between accumulated total after previous delivery and accumulated total after current delivery. The net accumulated total represents amount of fluid lost during cool down cycle. The net accumulated total is printed on the trip report.

$$\text{NET ACCUM TOTAL} = (\text{ACCUM TOTAL AFTER PREVIOUS DELIVERY}) - (\text{ACCUM TOTAL AFTER CURRENT DELIVERY})$$

Programming

The ACE II unit is shipped from the factory fully programmed per user specification; however, it is recommended to verify the program settings before installing the unit. Programming may be performed from the ACE II front panel, or from a personal computer using Hoffer configuration software. Connection to a personal computer may be established through the RS232 serial cable, or by using the infrared interface.

The program menu may not be entered while flow is present. This prevents parameters affecting the flow calculations to be changed during a delivery.

To enter the program mode press MENU key, and select Basic Settings or Advanced Settings. Software versions 1.00.6300 and later contain a Basic Settings Menu which has all of the most frequently used programming fields in a single top-level menu. The Advanced Settings menu is a multi-layer matrix of submenus and contains some of the least frequently needed menu items. Refer to the Menu Structure section for a detailed explanation of each programming field and a chart to assist in navigating through the menu to locate a desired menu item.

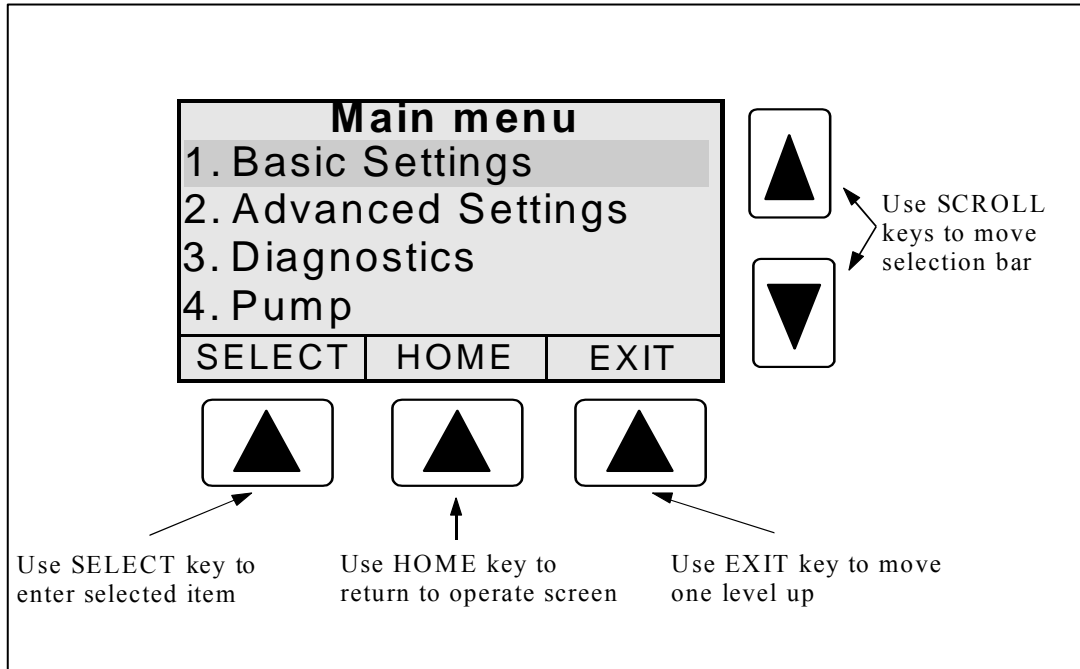

Main menu screen

Reviewing Settings

Program settings are displayed at the lowest level of the program menu. Once a menu item is selected, its value or setting can be changed using the EDIT key.

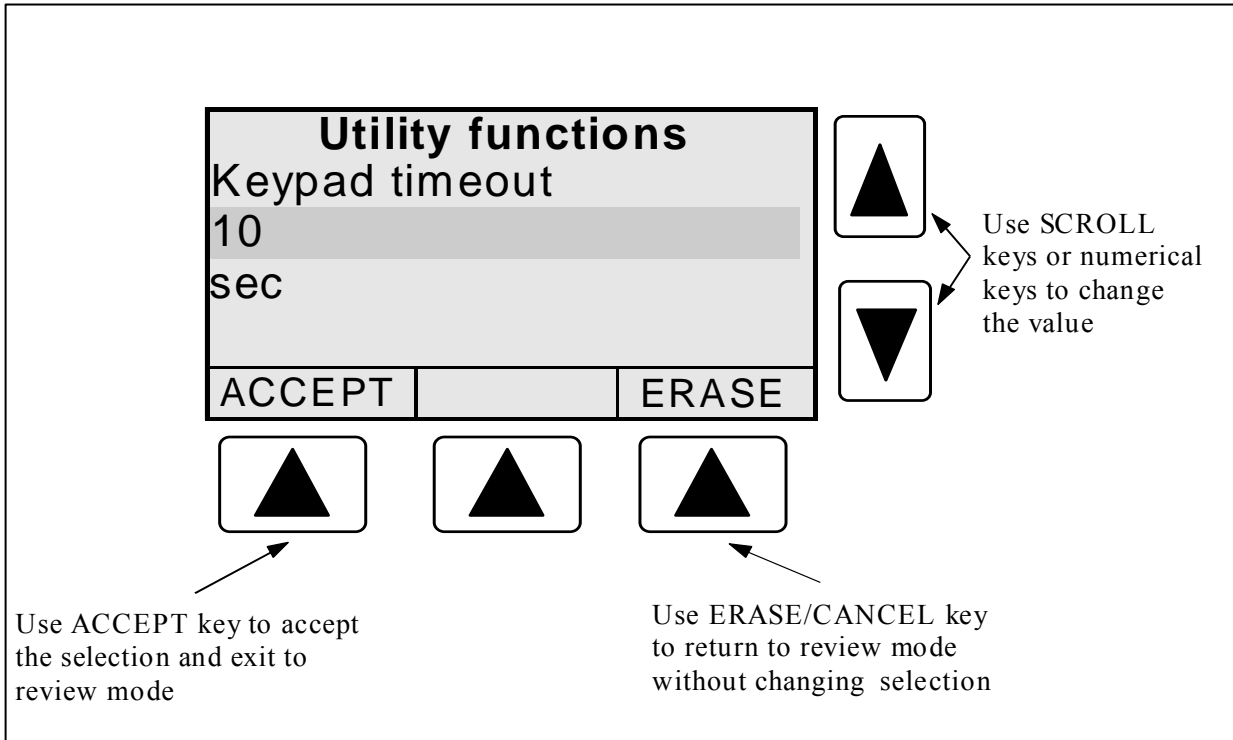

Editing Program Settings

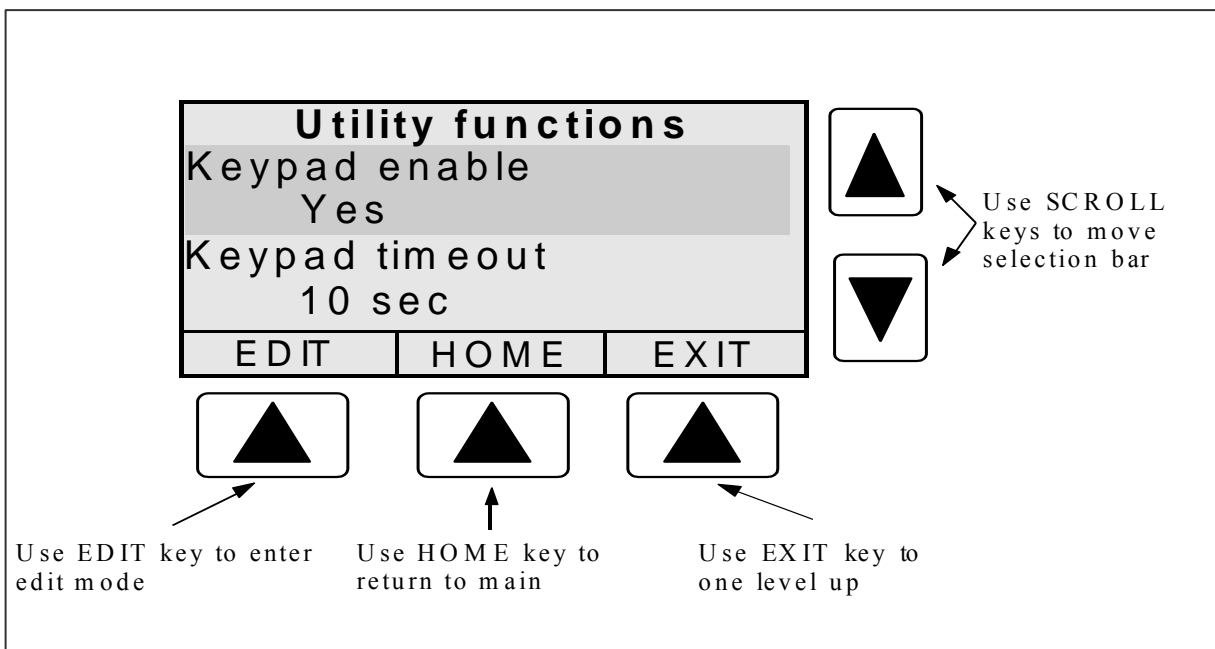

This page intentionally left blank.

Menu Structure

The menu structure varies depending on options installed and configuration of the ACE II unit. Not all of the menu items described in this manual may be available on all units.

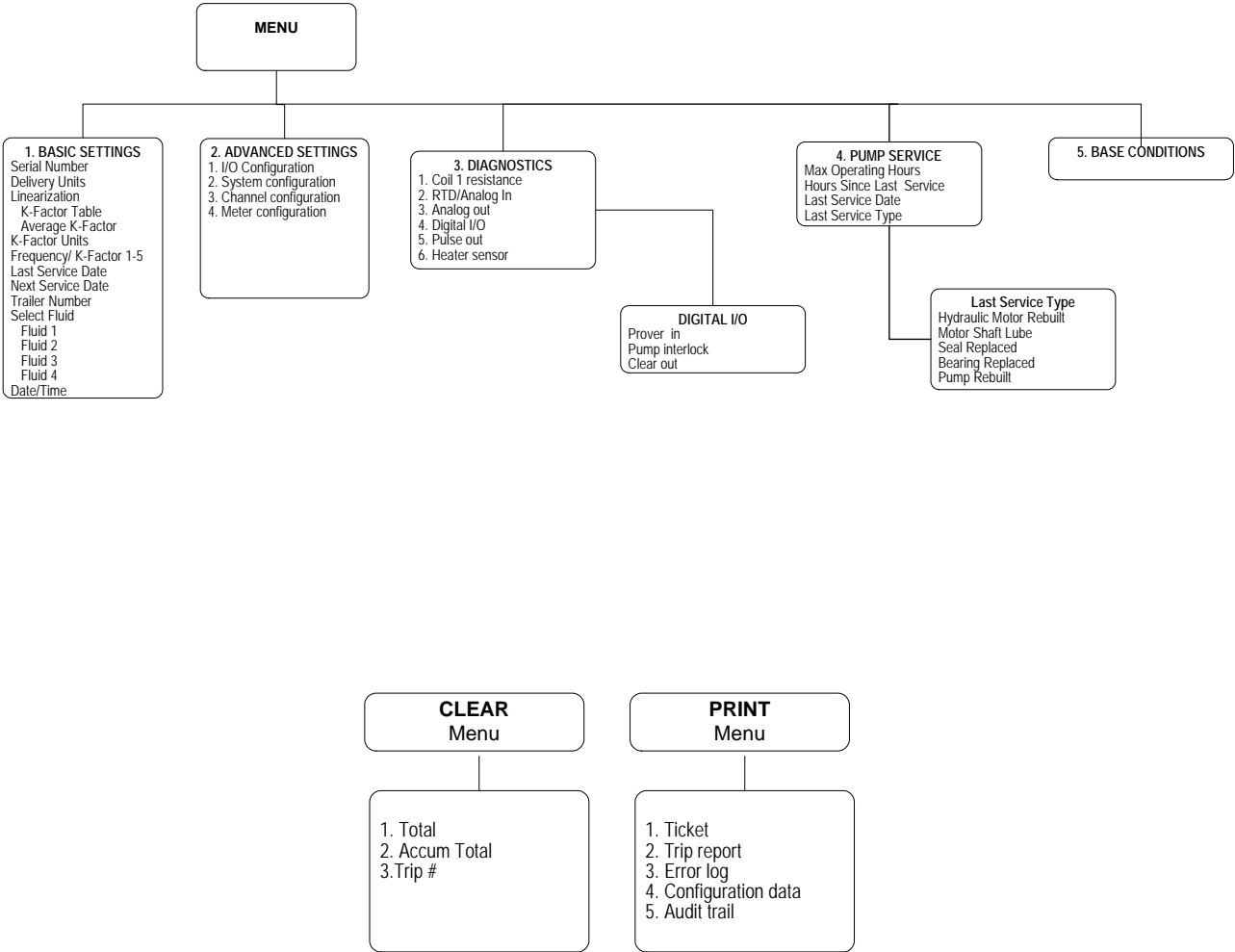

Advanced Settings Menu

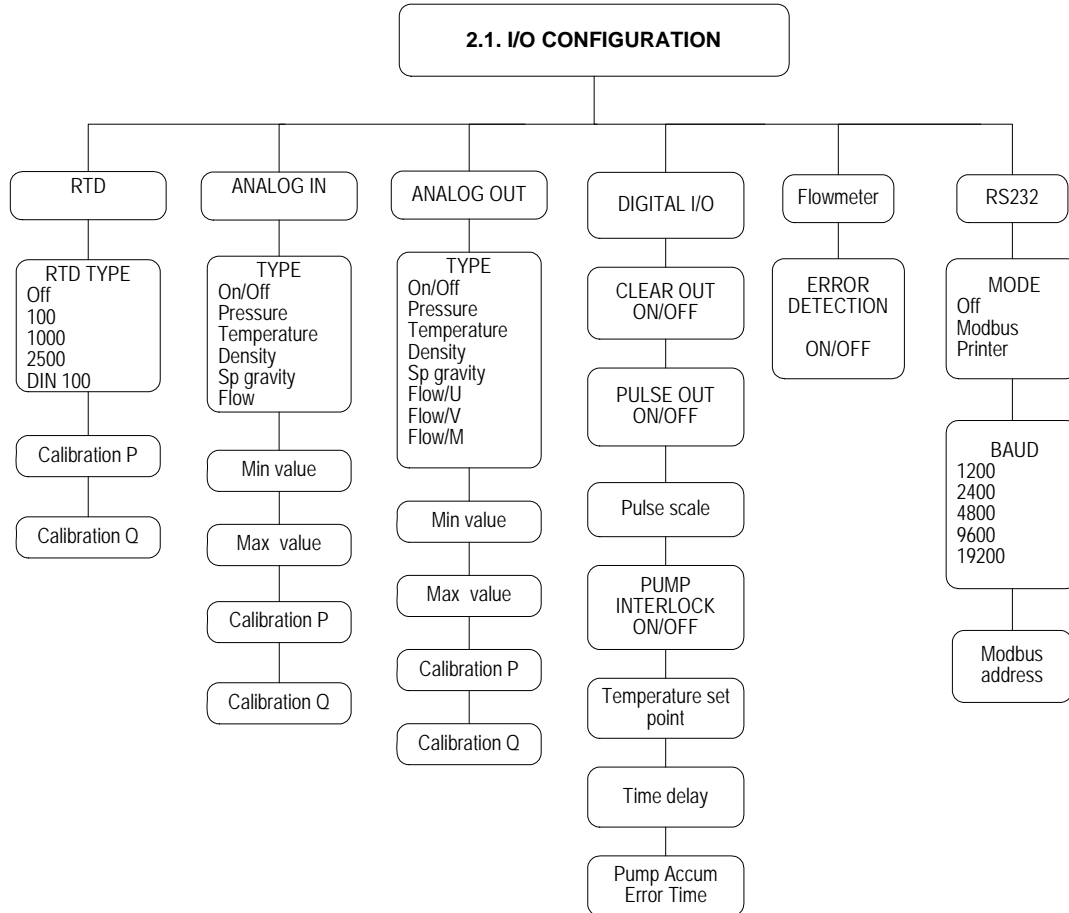

Advanced Settings Menu

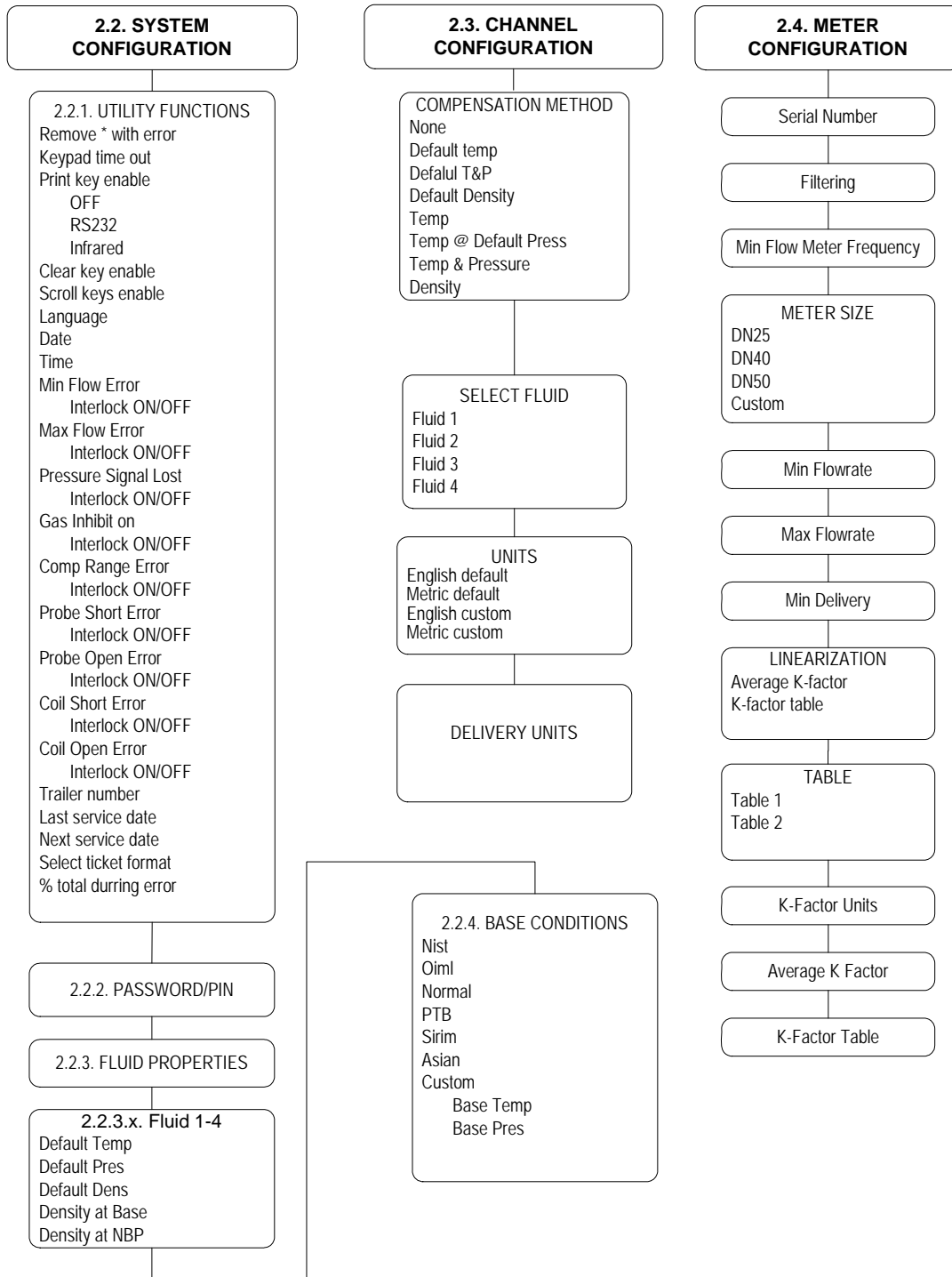

This page intentionally left blank.

Menu Fields

This section describes the program menu fields in detail. Whenever applicable the description is presented in the following format:

Menu Item	Selection	Comments
-----------	-----------	----------

Paragraph numbers in this chapter correspond to the menu field numbers in the ACE II.

A program menu item can be accessed by pressing the MENU key and then using SCROLL and SELECT keys as described in the Operation section of this manual.

Basic Settings

Software versions 1.00.6300 and later have a Basic Settings Menu containing the most frequently used Program fields in an easy to access top-level menu.

1. BASIC SETTINGS

<i>Menu</i>	<i>Selection</i>	<i>Comments</i>
Serial Number	Number	Enter the Flowmeter serial number. Alphanumeric entries can be made from WinConfig, but cannot be edited from the instrument.
Delivery Units	English Units Gallons @ NBP FT3 @ NTP LBS Metric Units Liters @ NBP M3 @ NTP KG	Select the default units displayed for Delivery Total. English / Metric units are available based on the type of units selected in the Channel Configuration in the Advanced Settings Menu.
Linearization	Average K K-Factor Table	Select whether a single Average K-Factor is used or a 5-point table of K-Factors over the flowmeters operating range.
K-factor units	Pulse / Gallon Pulse / Liter Pulse / FT3 Pulse / M3	Select units of measure for K-factor.
Average K-factor	Number	This menu is displayed when Average K-factor selected for linearization method. Enter a K-factor for the meter connected to this channel.
Last Service	Date	Enter the last service date.
Next Service	Date	Enter the next service date.
Trailer number	Number	Enter trailer number. Alphanumeric entries can be made from WinConfig, but cannot be edited from the instrument.

Menu Structure

<i>Menu</i>	<i>Selection</i>	<i>Comments</i>
Select fluid	Fluid 1 Fluid 2 Fluid 3 Fluid 4	Select a fluid table for the current application. Up to four different fluids can be programmed in the ACE II. Actual Fluid names will be displayed in this menu if service was specified at the time or order.
Date/Time	Enter date and time	This menu is used to set time and date.

2. ADVANCED SETTINGS

1. I/O Configuration

1.1. RTD

<i>Menu item</i>	<i>Selection</i>	<i>Comments</i>
RTD Type	Off 100 1000 2500 DIN	Select a type of RTD probe. 100, 1000, 2500 are platinum 3902 material DIN is 100 Ohm platinum 0385 material
Calibration P	Number	See calibration procedure
Calibration Q	Number	See calibration procedure

1.2. Analog Input

<i>Menu item</i>	<i>Selection</i>	<i>Comments</i>
Function Off	Pressure Temperature Density Sp gravity Flow	Select a desired function for the analog input.
Min value	Number	Enter a number corresponding to the minimum value for the input range, in the units selected for the input.
Max value	Number	Enter a number corresponding to the maximum value for the input range, in the units selected for the input
Calibration P	Number	See calibration procedure
Calibration Q	Number	See calibration procedure

1.3. Analog Output

<i>Menu item</i>	<i>Selection</i>	<i>Comments</i>
Function Off	Pressure Temperature Density Sp gravity Flow/M Flow/V Flow/U	Select a desired function for the analog output.
Min value	Number	Enter a number corresponding to the minimum value for the analog output range.
Max value	Number	Enter a number corresponding to the maximum value for the analog output range.
Calibration P	Number	See calibration procedure.
Calibration Q	Number	See calibration procedure.

1.4. Digital I/O

<i>Menu item</i>	<i>Selection</i>	<i>Comments</i>
Clear out	ON OFF	Select "ON" to enable the Clear Out function.
Pulse Out	Off Pulse/U Pulse/V Pulse/M	Select a desired function for the Pulse Out.
Pulse Out Scale	Number	Enter a scaling factor for pulse out. "1" means one pulse is output for each unit of measure.
Pump Interlock	ON OFF	Select "ON" to enable the Pump Interlock function.
Temp Set Point	Number	Enter a temperature set point to be reached during cool down cycle, before the timer starts counting.
Time Delay	Number	Enter a time delay in seconds before pump relay is enabled after reaching the temperature set point.
Pump Error Time	Number	Enter Pump accumulated error time in seconds. Refer to WinConfig program for a selection of errors for Pump Interlock function.

1.5. Flowmeter

<i>Menu item</i>	<i>Selection</i>	<i>Comments</i>
Error Detect	ON OFF	Select "ON" to enable the pulse error detection function. This function is available for dual coil meters only.

1.6. RS232 Port

<i>Menu item</i>	<i>Selection</i>	<i>Comments</i>
Mode Off	Modbus Printer	Select Modbus for communication with a PC computer or Modbus master. Select Printer for printing function.
Baud 1200	2400 4800 9600 19200	Select a desired baud rate.

2. System Configuration

2.1. Utility Functions

<i>Menu item</i>	<i>Selection</i>	<i>Comments</i>
Remove* with error	Yes No	Select “Yes” to remove asterisks with selected errors.
Keypad time out	Enter a number of seconds Range: 0-	If the unit is left in the program mode, it will switch back to the operate mode when limit is reached. Zero means the time out function is disabled.
Print key enable	Off RS232 Infrared	If “No” is selected the front panel Print key is disabled. To enable, press any key and enter a password when prompted.
Clear key enable	Yes No	If “No” is selected the front panel Clear key is disabled. To enable, press any key and enter a password when prompted.
Scroll Keys enable	Yes No	If “No” is selected the front panel Scroll keys is disabled. To enable, press any key and enter a password when prompted.
Language Engl	ish Spanish Portuguese	Select a desired language.
Date Format	mm/dd/yy dd/mm/yy	Select a desired date format.
Date/Time	Enter date and time	This menu is used to set time and date. Also available in Basic Settings.

<i>Menu item</i>	<i>Selection</i>	<i>Comments</i>
Minimum Flow Error Maximum Flow Error Pressure Signal Lost Gas Inhibit Error Compensation Range Error Probe Short Error Probe Open Error Coil Short Error Coil Open Error	On/Off	Pump Interlock on / Pump Interlock off.
Trailer number	Number	Enter trailer number. Also available in Basic Settings.
Last service date	Date	Enter the last service date. Also available in Basic Settings.
Next service date	Date	Enter the next service date. Also available in Basic Settings.
Ticket format	Ticket 1 Ticket 2	Select a ticket format for printed tickets.
% total error	Number	Enter allowable percentage of error for pulse security function (pulse error detect).

2.2. Password/Pin

<i>Menu item</i>	<i>Selection</i>	<i>Comments</i>
Supervisor pin #1-5	Number	Enter a 4 digit for each supervisor pin number.
Reenter password	Number	Enter the supervisor password again to confirm.
Supervisor password	Number	Enter a 4 digit for supervisor password.
Operator pin #1-5	Number	Enter a 4 digit for each operator pin number.
Operator password	Number	Enter a 4 digit for operator password.
Reenter password	Number	Enter the operator password again to confirm.

2.3. Fluid Properties

Fluid 1

<i>Menu item</i>	<i>Selection</i>	<i>Comments</i>
Default Temperature	Number	Default temperature for Fluid 1.
Default Pressure	Number	Default pressure for Fluid 1.
Default Density	Number	Default density for Fluid 1.
Density at Base	Number	Density at reference temperature for Fluid 1.

Density at NBP	Number	Density at the normal boiling point for Fluid 1.
----------------	--------	--

Fluid 2

Menu item	Selection	Comments
Default Temperature	Number	Default temperature for Fluid 2.
Default Pressure	Number	Default pressure for Fluid 2.
Default Density	Number	Default density for Fluid 2.
Density at Base	Number	Density at reference temperature for Fluid 2.
Density at NBP	Number	Density at the normal boiling point for Fluid 2.

Fluid 3

Menu item	Selection	Comments
Default Temperature	Number	Default temperature for Fluid 3.
Default Pressure	Number	Default pressure for Fluid 3.
Default Density	Number	Default density for Fluid 3.
Density at Base	Number	Density at reference temperature for Fluid 3.
Density at NBP	Number	Density at the normal boiling point for Fluid 3.

Fluid 4

Menu item	Selection	Comments
Default Temperature	Number	Default temperature for Fluid 4.
Default Pressure	Number	Default pressure for Fluid 4.
Default Density	Number	Default density for Fluid 4.
Density at Base	Number	Density at reference temperature for Fluid 4.
Density at NBP	Number	Density at the normal boiling point for Fluid 4.

2.4. Base Conditions

Menu item	Selection	Comments
Base conditions	NIST OIML NORMAL PTB SIRIM ASIAN CUSTOM	Select a predefined set of base conditions, or select “custom” to enter user defined base conditions. Base conditions are used to calculate corrected volume.

3. Channel Configuration

Menu item	Selection	Comments
Compensation method	Default temperature Default T&P Temperature Temp & Default P T&P Density	Select an appropriate compensation method. For T, P, D compensation an associated sensor has to be connected and an analog input has to be programmed accordingly. When a sensor fails, the default value is used for calculations.
Select fluid	Fluid 1 Fluid 2 Fluid 3 Fluid 4	Select a fluid table for the current application. Up to four different fluids can be programmed in the ACE II. Actual Fluid names will be displayed in this menu if service was specified at the time or order. Also available in Basic Settings.
Units	English default English custom Metric default Metric custom	Select a desired set of units of measure. For a complete list of available units and conversion factors refer to Appendix B.

4. Meter Configuration

Menu item	Selection	Comments
On/off	On Off	“On” has to be selected to activate the flow channel operation.
Serial number	Number	Enter up to a 10- digit flow meter serial number. Also available in Basic Settings.
Filtering	Number (0-100)	Enter a whole number between 0 and 100. This number represents the amount of filtering applied to the input signal coming from a meter. Default value is 0.
Minimum meter frequency	Number	Enter a frequency in Hz that is below an operating range of input frequency. Any signal at frequency below the Minimum value is considered “noise” and it will be rejected. Default value is 0.
Meter size	DN25 DN40 DN50 Custom	Select meter size installed in the ACE II system.
Min Flow rate	Number	Enter Min Flow rate value for custom size meter.
Max Flow rate	Number	Enter Max Flow rate value for custom size meter.
Min Delivery	Number	Enter Min Delivery value for custom size meter.
Linearization Average	K-factor K-factor table	Select an applicable method. The menus below will be displayed only when the associated method is selected. Also available in Basic Settings.
Table 1 Table 2	Table 1 Table 2	Select K-Factor Table 1 or Table 2 to use for linearization. Multiple tables allow for easy switching between two different turbine meters.
K-factor units		Select units of measure for K-factor. Also available in Basic Settings.
Average K-factor	Number	This menu is displayed when Average K-factor selected for linearization method. Enter a K-factor for the meter connected to this channel. Also available in Basic Settings.

Flowmeter Size Selection

ACE II provides Flowmeter Size Selection in the Meter Menu to set values for Minimum Flowrate, Maximum Flowrate, and Minimum Delivery. The following table lists the meter size options and the corresponding parameters.

FLOWMETER SIZE	MIN FLOWRATE L/min (gal/min)	MAX FLOWRATE L/min (gal/min)	MIN DELIVERY Kg (lbs)
DN25	46 (12.152)	230 (60.760)	10 (22.046)
DN40	100 (26.417)	500 (132.086)	100 (220)
DN50	170 (44.909)	850 (224.546)	100 (220)
CUSTOM	User Defined	User Defined	User Defined

ACEII / PROVER Users

NOTE: *Hoffer Flow Controls recommends programming the ACEII with a 5-point K-Factor table as calculated by the prover calibration and indicated on the Final Calibration Report printout.*

After all 5 prover calibration points have been calculated, the new K/M-FACTOR must be entered into the ACEII from the METER CONFIGURATION menu using the following procedure.

1. Press MENU
2. Select BASIC SETTINGS
3. SCROLL down to LINEARIZATION and press EDIT
4. Select K-FACTOR TABLE and press ACCEPT
5. SCROLL down to TBL1 POINT #1 – FREQ
6. EDIT TBL1 POINT #1 – FREQ and enter point #1 Freq from the Final Calibration Report printout
7. Press ACCEPT
8. EDIT TBL1 POINT #1 – FACTOR and enter point #1 K-Factor from the Final Calibration Report printout
9. Press ACCEPT
10. Continue entering the calibration data in this manner until all 5 points have been entered
11. Press HOME
12. Select YES at Save Data prompt
13. Select RESET at Reset prompt

This page intentionally left blank.

Diagnostics

Diagnostics Menu

ACE II provides diagnostic functions for testing Inputs and Outputs to verify hardware functionality. To access Diagnostics functions press MENU, scroll to Diagnostics, and press SELECT.

Diagnostics functions:

- Coil Resistance
- RTD/Analog In
- Analog Out
- Digital I/O
- Pulse Out
- Heater Sensor

Coil Resistance

The coil resistance diagnostic displays the resistance measurement ($\pm 10\%$) of the flowmeter pickup coil in Ohms. Normal coil resistance should be in the range of 1500 – 2500 Ohms.

RTD/ Analog Input

RTD and Analog diagnostic screen displays the A/D (analog to digital converter) counts for both the RTD input and the Analog Input (AI). A/D counts for a configured input should always be between 0 and 4095 during normal operation. As the transmitter signal increases, the number of A/D counts should also increase. As the RTD temperature increases, the number of A/D counts should also increase. If the count displayed is 0 or 4095, it means that either the input has not been configured or calibrated, or there is an RTD or Transmitter failure.

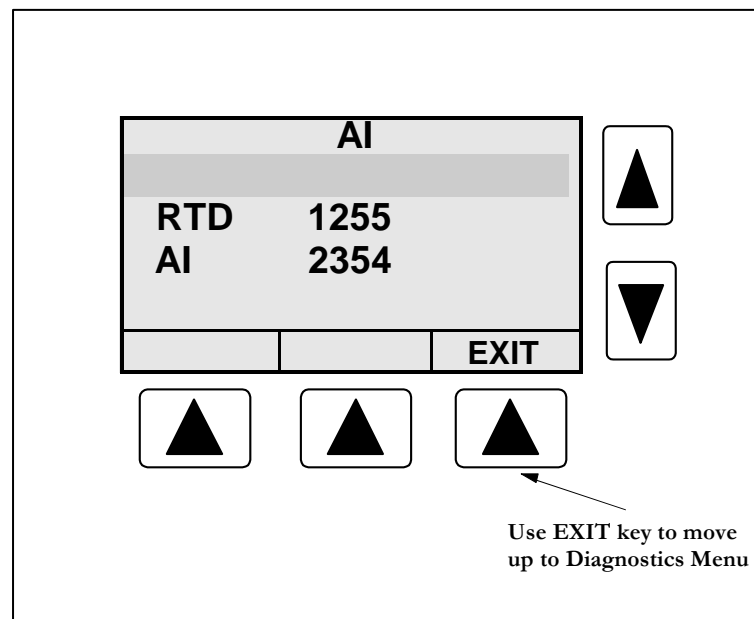

Figure 2. RTD/Analog Input Diagnostics Screen

Analog Output

The Analog Output may be tested by connecting a milliamp meter, to pins A and B of the analog output connector located on the ACE II rear panel. Pressing the SELECT key selects the output. Use the SCROLL keys to increase or decrease the number of D/A counts. As the number increases, the output current should increase. As the number decreases, the output current should decrease. The range of D/A counts is from 0 to 4095. At 0 counts the output current should be close to 4 mA; at 4095 the current should be close to 20 mA.

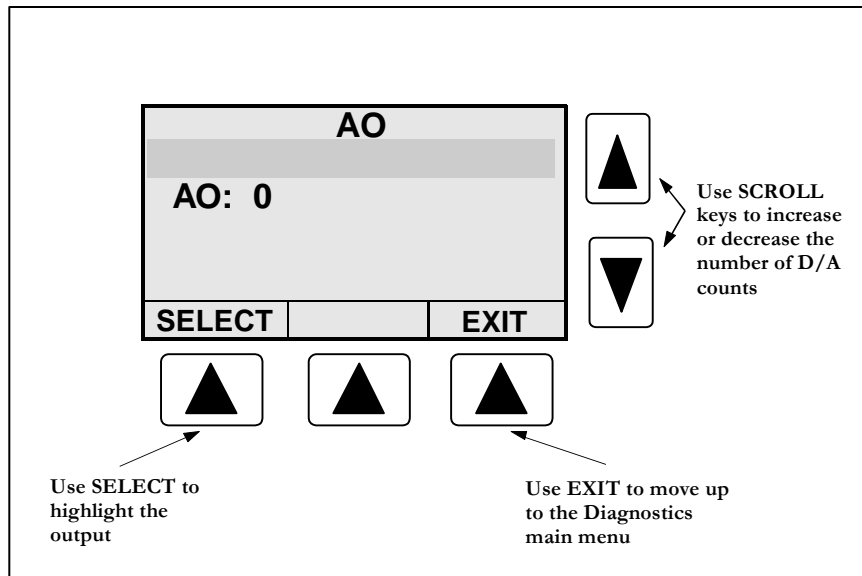

Figure 3. Analog Output Diagnostics Screen.

Digital I/O

The Digital I/O diagnostics is used to verify operation of the digital inputs and outputs. The state of the Prover input is displayed as a 1 or a 0. A 1 represents a high signal level and 0 a low signal level. When a signal is applied to an input, the corresponding digit will toggle accordingly. For the Pump Interlock and Clear Outputs, press SELECT to highlight the desired output and use the SCROLL keys to toggle the output between high and low levels. The output may be monitored with a meter connected to the corresponding output connector on the ACE II rear panel.

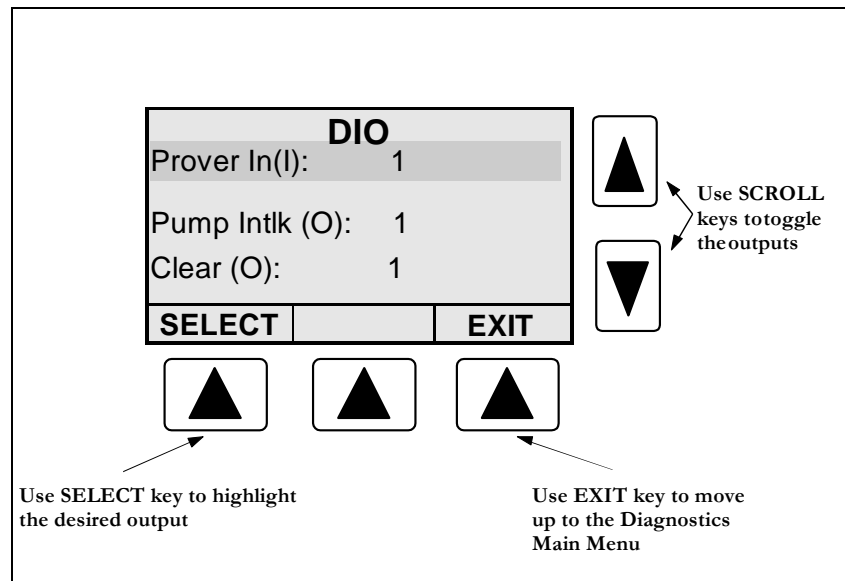

Figure 4. Digital I/O Diagnostics Screen

Pulse Output

The pulse output may be tested by connecting an oscilloscope or a voltmeter to the output connector on the ACE II rear panel. Press the SELECT key to highlight the output and the SCROLL Keys toggle the output between high and low states. A 1 outputs a high signal and a 0 outputs a low signal.

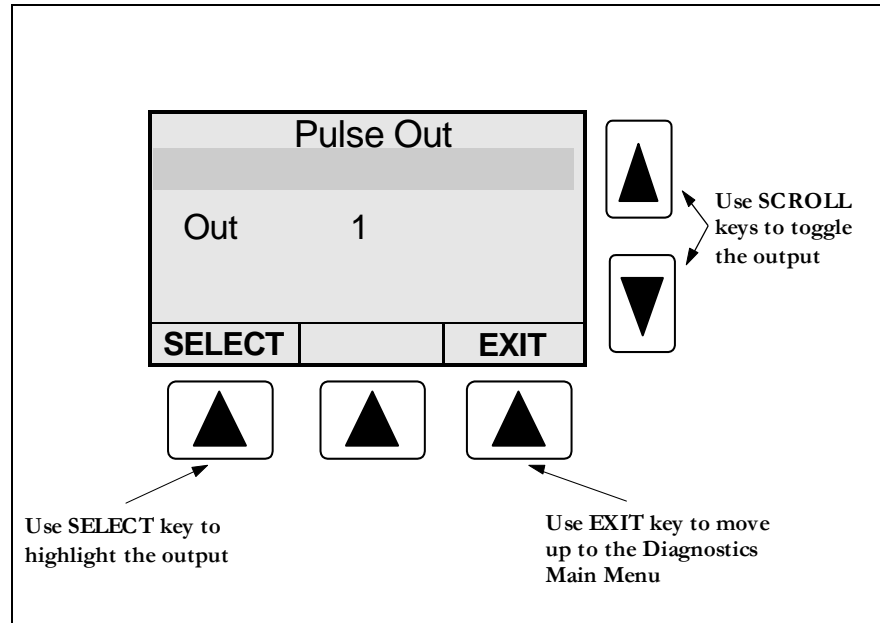

Figure 5. Pulse Output Diagnostics Screen.

Heater Sensor

This diagnostic feature displays the temperature (°C) measured by the digital temperature sensor on the ACE II front panel.

Base Conditions

Base temperature and pressure selected in the program menu can be viewed in this menu. ACE II uses base conditions to calculate corrected total volume and corrected flow rate.

Communications

ACE II is equipped with RS232 serial port and the optional infra-red port. The serial port has to be configured for either printing or Modbus functions in the ACE menu at Program/IO Configuration/RS232. It can be used for printing, programming the ACE II settings, communication with a personal computer, or with a Modbus master device. For programming ACE II from a personal computer using Hoffer configuration program, refer to the WinConfig section of this manual.

ACE II supports standard MODBUS RTU (binary) encoding. The following tables list Modbus addresses for the available Modbus commands.

Function Code 04 (Read Input Registers)

ABSOLUTE ADDRESS	DESCRIPTION
30001	Uncorrected Rate (X1, X10, X100 or X1000)
30002	High Word of Uncorrected Total
30003	Low Word of Uncorrected Total (X1, X10, X100 or X1000)
30004	High Word of Uncorrected Accum Total
30005	Low Word of Uncorrected Accum Total
30006	Corrected Rate (Mass or Volume) (X1, X10, X100 or X1000)
30007	High Word of Corrected Total
30008	Low Word of Corrected Total (X1, X10, X100 or X1000)
30009	High Word of Corrected Accum Total
30010	Low Word of Corrected Accum Total
30011 Pressure	
30012	Density X 1000
30013 Temperature	perature (Kelvin)
30014 OPEN	
30015 OPEN	
30016 OPEN	

Function Code 01 (Coil Status)

ABSOLUTE ADDRESS	DESCRIPTION
00002-00008 OPEN	
00009	Clear Totals
00010	Clear Accum Totals

This page intentionally left blank.

Installation

This section includes information specific to the ACE II flow computer installation. For installation information on the turbine flowmeter, temperature probe, pressure probe, or other equipment refer to the individual item's technical manuals.

Location of the ACE II

The ACE should be mounted at operator eye-level for the best viewing angle. Install the ACE on a horizontal surface near the access door of the trailer. Allow enough clearance for easy access to the signal cables.

CAUTION !

ACE II MUST BE INSTALLED IN THE HORIZONTAL POSITION. MOUNTING IN THIS POSITION IS CRITICAL TO ALLOW THE SHOCK MOUNTS TO FUNCTION PROPERLY AND PREVENT DAMAGE CAUSED BY TRUCK VIBRATION.

WARNING !

DO NOT OVER-TIGHTEN MOUNTING BOLTS. RECOMMENDED TIGHTENING TORQUE IS 105 LBS-IN. OVER-TIGHTENING MAY CAUSE SHOCK MOUNTS TO BREAK.

Cable Installation

- Install and secure cables to avoid contact with cold pipes.
- Attach cables to the appropriate connector on the back of the ACE.
- The power cable is a three-wire cable. Red lead connects to positive (+) battery lead. Black lead connects to negative (-) lead. White lead connects to chassis ground.
- The ACE has no power switch. Hoffer recommends providing the ACE II with a direct power lead from the battery. This will reduce interference from other operating systems. If a switch is required, HFC recommends using the main power switch on the trailer.
- Install dust caps on any unused connections.
- Tighten all cable assemblies.

ACE II Program Setup

After the installation of components is complete, the setup parameters must be reviewed prior to using the ACE II for customer delivery.

Printer Installation

The ACE II printer requires two cables for proper operation; one for connection to the ACE II RS232 port and the other for connection to the DC power supply.

For further information on the ACE II installation refer to the installation drawings located in the back of this manual.

This page intentionally left blank.

WinConfig Program

The Nova-Flow WinConfig Program allows for quick, easy configuration of the ACE II using a personal computer. All programmable fields available locally on the ACE II are also accessible through the WinConfig program. This chapter provides guidelines for basic operations available through WinConfig.

Installation

Minimum system requirements:

486 Processor running Windows 95/NT and a Communications Port.

Installation:

Insert the provided disk into the computer.

Click on the “Start” menu on the Windows desktop taskbar and select “Run”.

Click on “Browse” and search for the drive in which the disk is located.

Select “Setup”, and let the Setup Wizard guide the installation process.

Startup

Below is an illustration of the “Startup” screen that will appear when the WinConfig program is invoked. Make certain that ACE II is powered up before attempting to establish communications. Connection may be made to the ACE II via RS-232 communications cable or the infrared interface. Click on “Communications” then on “Initialize” and select the appropriate Com port designation and Com port type. After making the appropriate selections, click on “OK” and verify that the COMM Window in the bottom right corner of the screen displays “OK”. After establishing Communications, the Startup screen will display the detected Unit Type and software version.

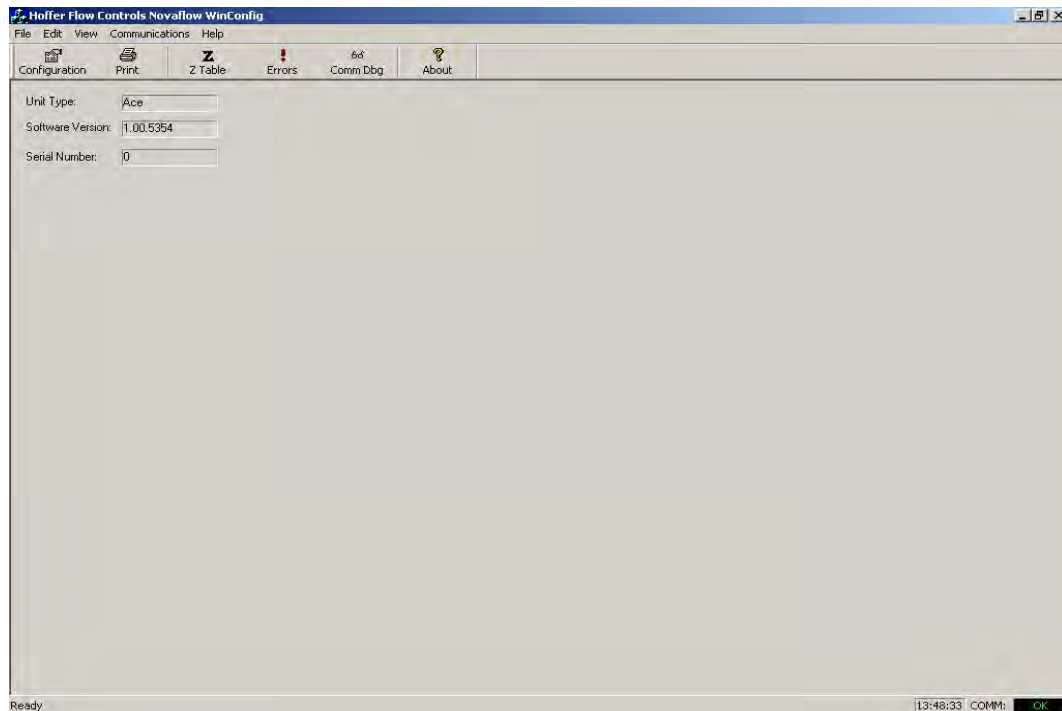

Figure 1. WinConfig Startup Screen

Print

Clicking on “Print” in the Startup screen will print a copy of the program med configuration parameters to a printer connected to the personal com puter. A preview of the printout m ay be display ed by selecting “File” and then “Print Preview”.

Configuration

After communications have been established, clicking on “Configuration” uploads program information from ACE II. Once the upload is com plete, the I/O m enu will be displayed. Other available m enu items may be selected by clicking on the appropriate tabs at the top of the screen.

I/O Configuration Menu

The I/O Configuration Menu consists of two sub menus, Analog I/O and Digital I/O. The Configuration Menu is used to assign, configure, and calibrate inputs and out puts. Some diagnostic functions are also available in the I/O Menu.

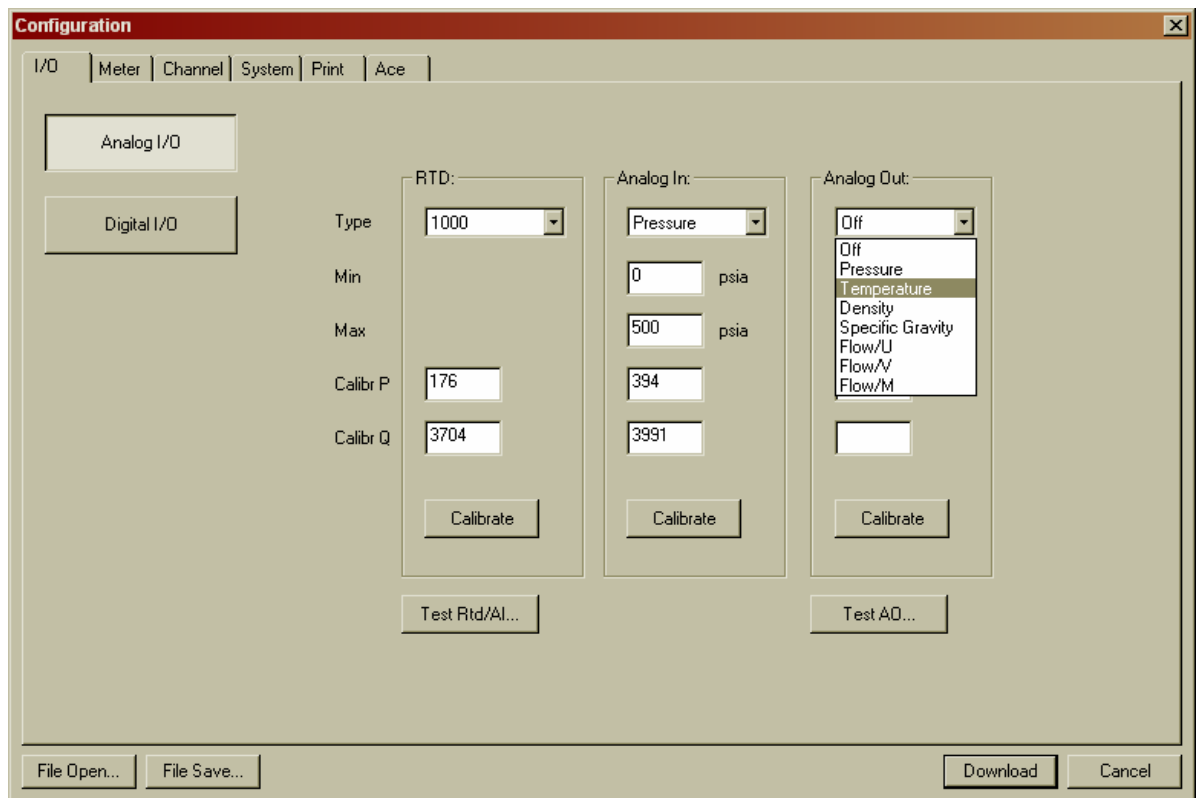

Figure 2. Analog I/O Configuration Menu.

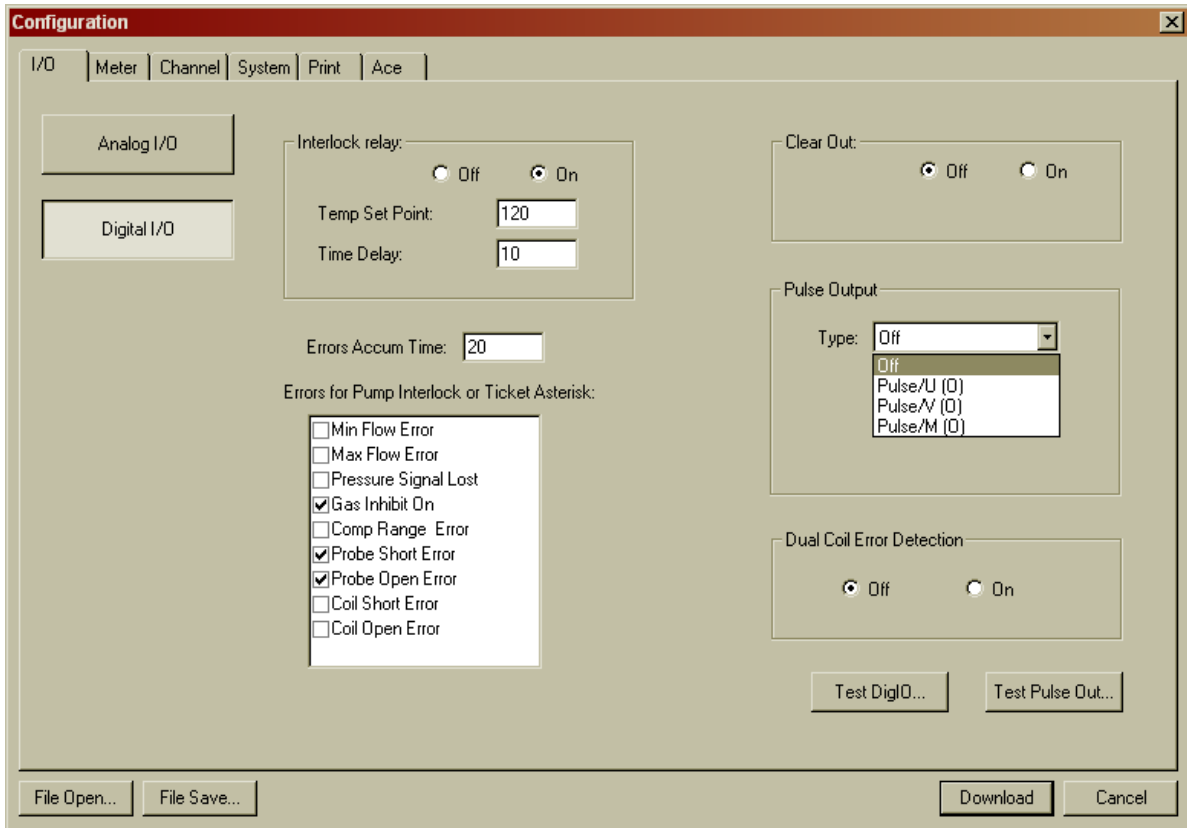

Figure 3. Digital I/O Configuration Menu.

Pump Interlock Option

A list of error conditions is provided, so that the user may select specific operational errors that will disable the pump relay and/or remove asterisks from the ticket printout. When the selected operating error occurs for a period exceeding the entry in the Errors Accumulated Time field, the pump relay will be disabled and flow stopped.

Meter Configuration Menu

The Meter Configuration Menu is used to configure all parameters associated with the connected flow meter(s). Included in this menu are fields for the meter serial number, meter size settings, and linearization parameters.

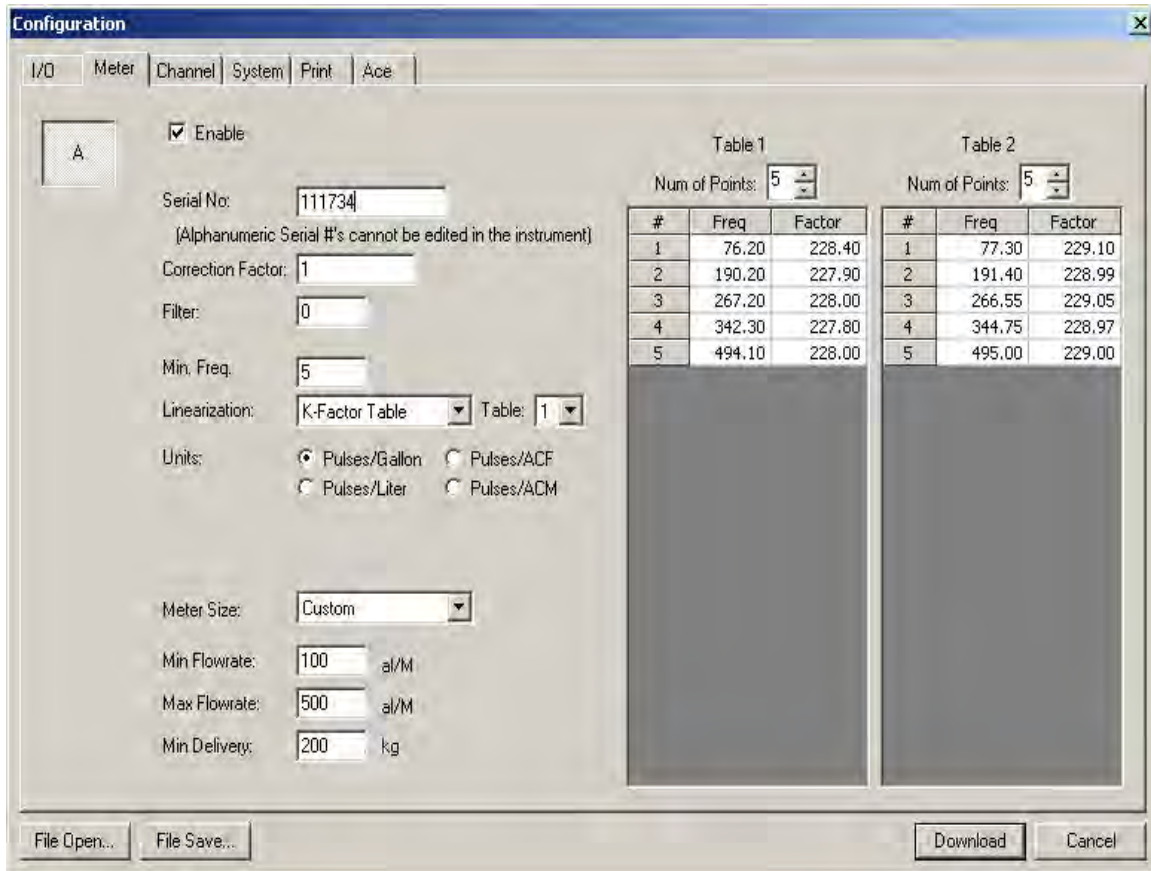

Figure 4. Meter Configuration Menu.

Channel Configuration Menu

The Channel Configuration Menu is used to configure metrological specifics such as compensation methods, fluid selection and unit selections. Modbus multipliers are

available for Total and Flowrate to increase the resolution of data retrieved via serial Modbus communications. See the Communications chapter for more information on Modbus protocol.

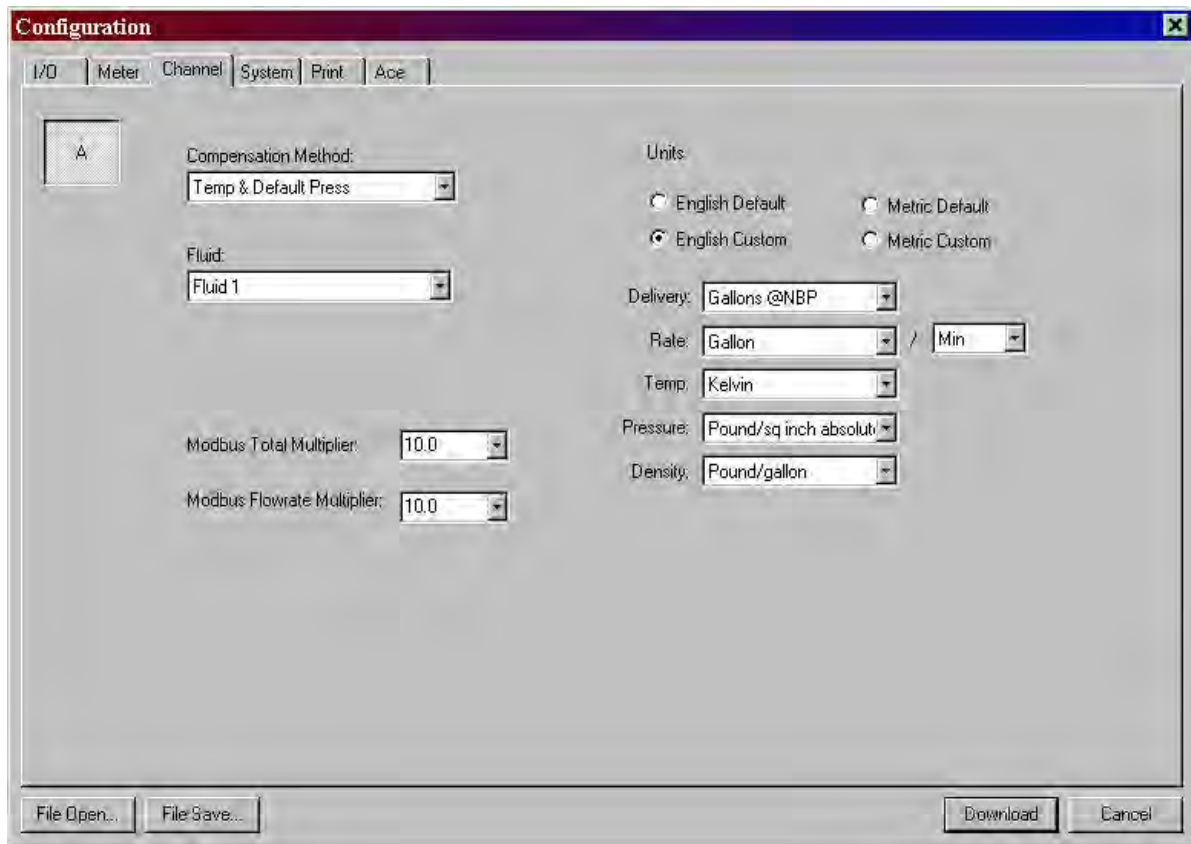

Figure 5. Channel Configuration Menu.

System Configuration Menu

The System Configuration Menu provides four lower level menus as follows:

Utility Functions: Program the Menu timeout feature and lock front panel buttons.

Password/Pin: Program two levels of password protection for up to ten users.

Fluid Properties: Provides configuration parameters for up to four different fluids.

Base Conditions: Select the appropriate operating conditions.

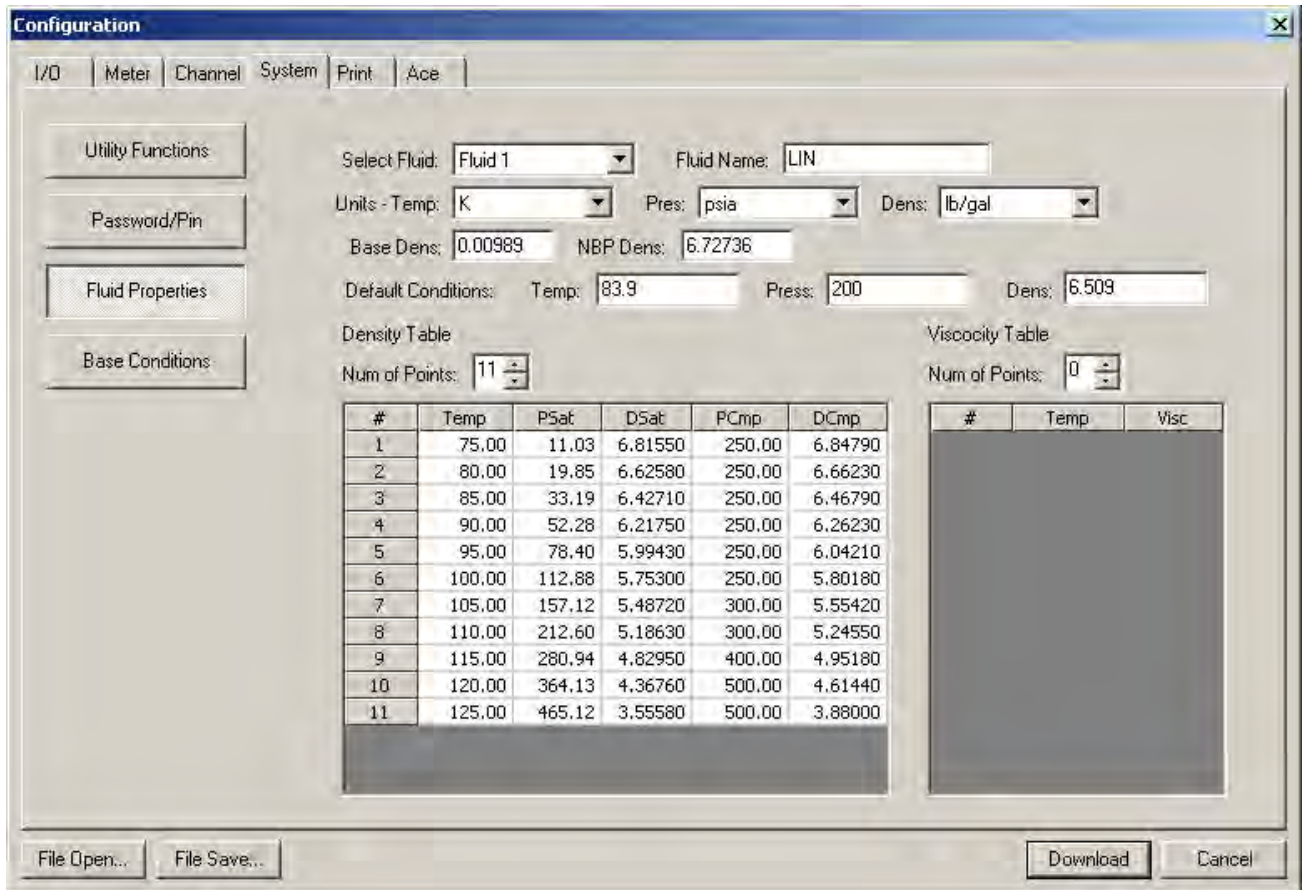

Figure 6. System Configuration Menu (Fluid Properties Shown).

Print Menu

The Print Menu is used to select the printer that is connected to the ACE II, define the associated column width, and select the ticket format for printing.

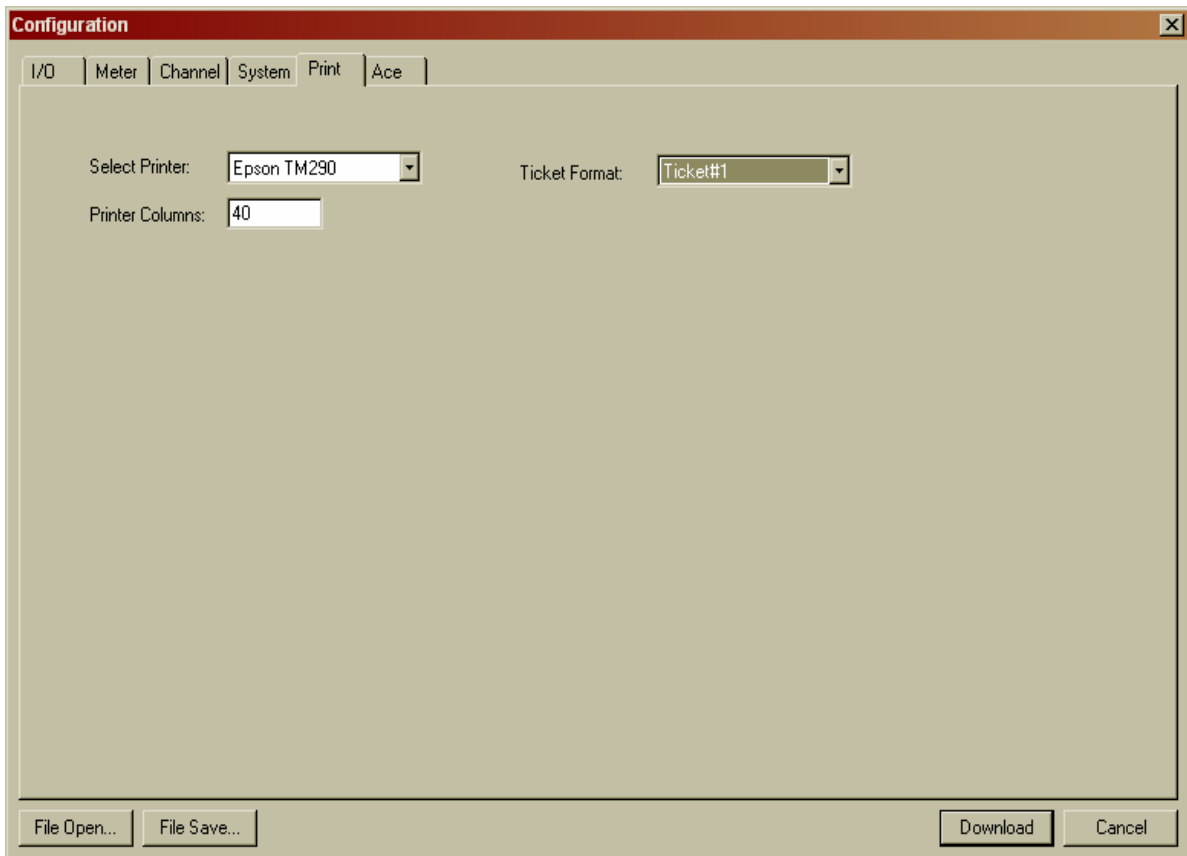

Figure 7. Print Menu.

ACE Menu

The ACE menu provides special configuration parameters for the ACE II. The trailer number may be entered, service dates recorded, and selections made for parameters to be displayed. There is also a tool to configure custom messages that will appear on the ACE II display as well as the ticket printout. Specifying codes are used for fluid name, temperature range and base conditions. This allows the display to automatically update when operating parameters change. These special messages are only configurable using the Windows Configuration Program.

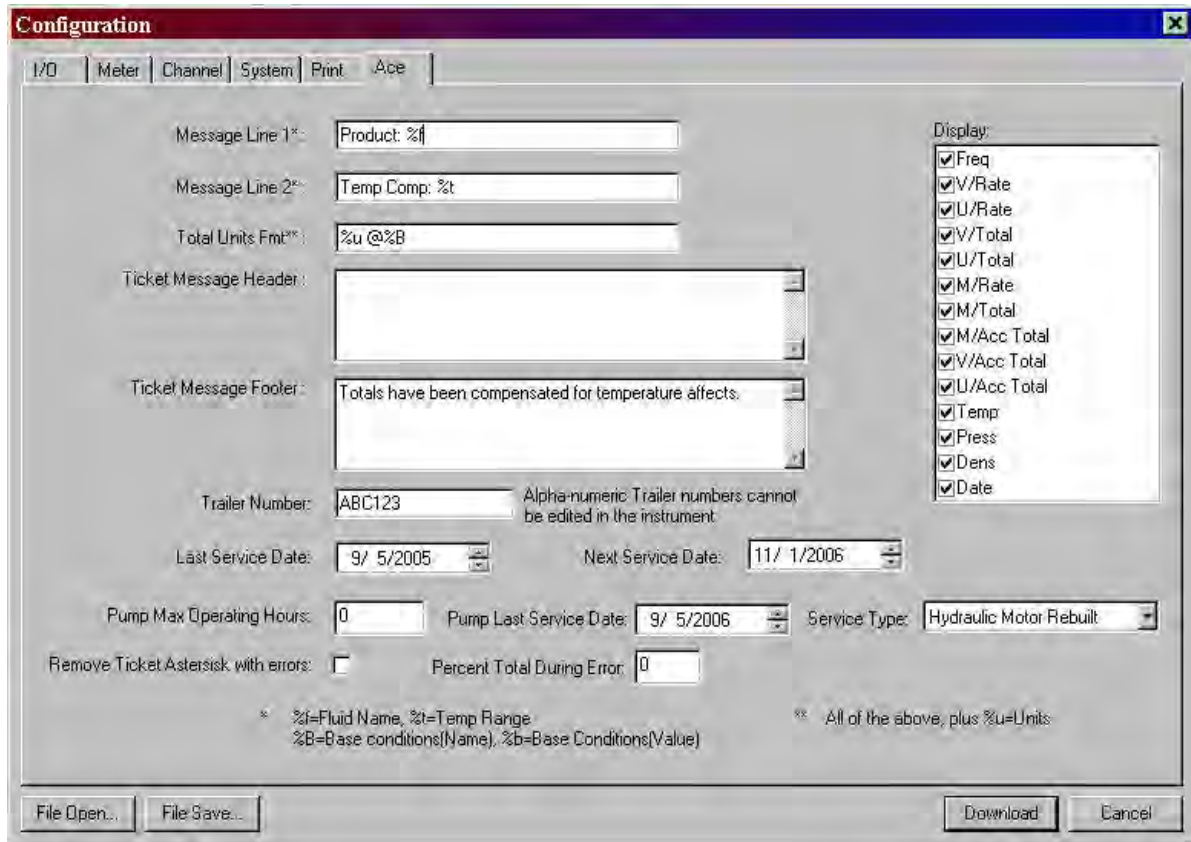

Figure 8. ACE Menu.

Downloading the Configuration

When all required parameters have been programmed, the configuration may be downloaded to the ACE II by clicking on the “Download” button located in the bottom right corner of the configuration screens. After the configuration has been downloaded, a software reset is required on the ACE II for the new configuration to take affect.

Configuration Files

WinConfig allows configurations to be saved as a file for future use. The two available file functions are File Open and File Save, which are described below.

Saving Configuration Files

After all required parameters have been programmed, click on the “File Save” button located in the bottom left corner of the configuration screens. When the “Save As” window appears, select the destination drive and directory, provide a name for the file and click on “Save”. All configuration files are given an .HFC extension.

Opening Configuration Files

To recall previous configurations, click on the “File Open” button located in the bottom left corner of the configuration screens. When the “Open” window appears, select the proper drive and directory, select the desired .HFC file, and then click on “Open”.

This page intentionally left blank.

Appendix A: Liquid Calculation Flow Chart

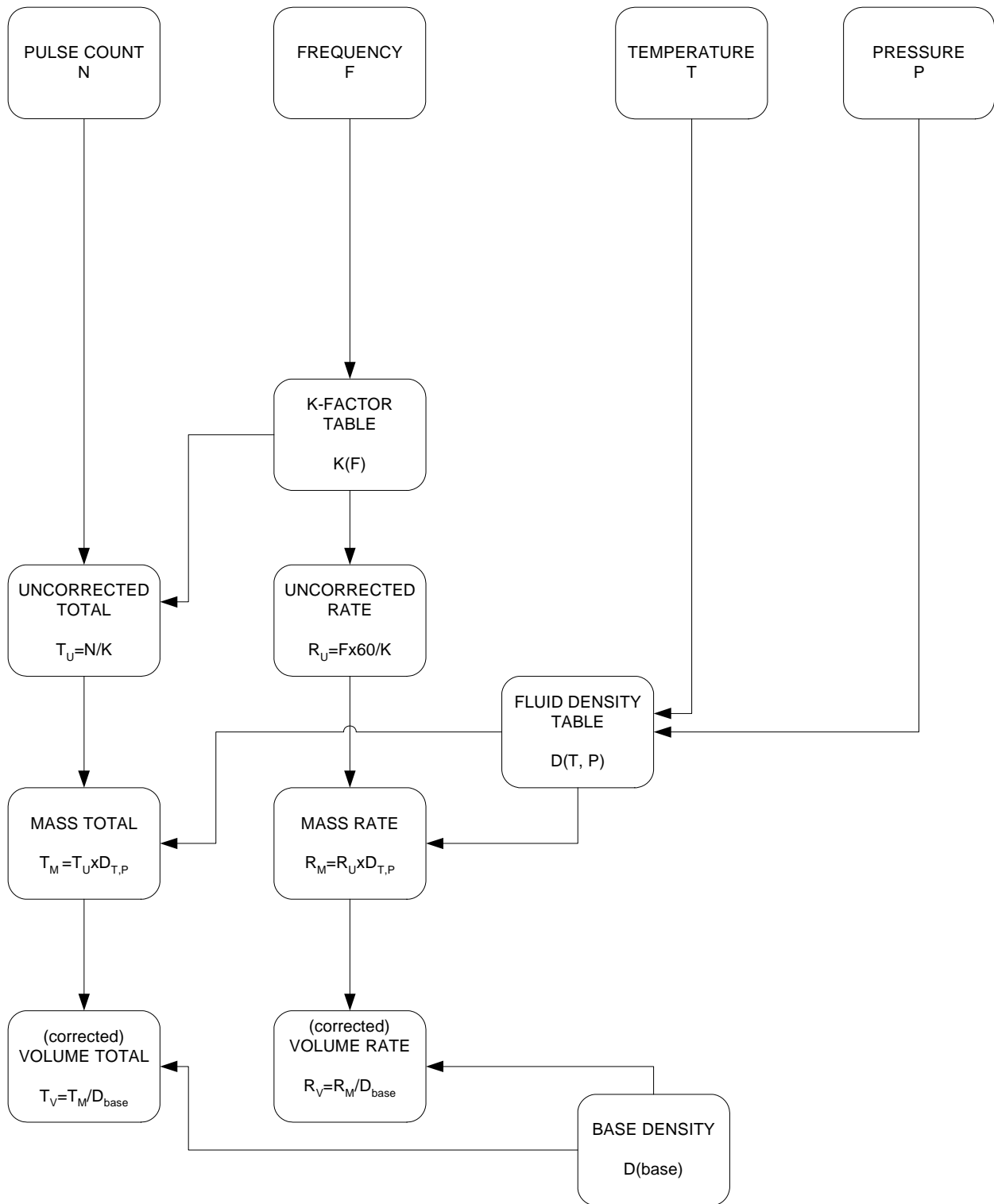

Appendix B: Units Of Measure

Liquid Volume

Full Name	Abbr. Name	Multiplier
Gallons GAL		1
Liter L		3.785411784
Milliliter ML	3785.411784	
Cubic feet	FT3	0.133680556
Pint PT		8
Fluid ounce	FLOZ	128
Barrel (oil)	BBL	.02380952381
Cubic meter	M3	0.003785412
Cubic centimeter	CC	3785.411784
Quart QT		4
Imperial gallon	IGAL	0.832674

Liquid Mass

Full Name	Abbr. Name	Multiplier
Pounds LB		1
Kilograms KG		0.45359237
Once OZ		16
Ton TON		0.0005
Metric ton	MTON	.00045
Gram G		453.59237

Temperature

Full Name	Abbr. Name	Multiplier	Offset
Fahrenheit F		1	0
Celsius C		0.555555556	-32.00
Kelvin K		0.555555556	+459.67
Rankine R		1	+459.67

Pressure

Full Name	Abbr. Name	Multiplier	Offset
Pound/sq inch absolute	PSIA	1	0
Atmosphere ATM		0.068045964	0
Pound/sq inch gauge	PSIG	1	-14.69595
Bar gauge	BAR-G	0.068947573	-0.944302
Bar absolute	BAR-A	0.068947573	0
Kilo Pascal gauge	KPA-G	6.894757293	-94.43024
Kilo Pascal absolute	KPA-A	6.894757293	0
Mega Pascal gauge	MPA-G	0.006894757	-0.09443
Mega Pascal absolute	MPA-A	0.006894757	0
kG/cm2-g KG/	CM2-G	0.070306958	-0.96292
kG/cm2-a KG/	CM2-A	0.070306958	0
Millimeter of water column	MM W.C.		
Inch of water column	IN W.C.	27.7075924	0
Millimeter of mercury	MM HG	51.71493257	0
Inch of mercury	IN HG	2.036020967	0

Density

Full Name	Abbr. Name	Multiplier
Pound/gallon LB/	GAL	1
Kilogram/liter KG/L		0.119826427
Pound/cubic feet	LB/FT3	7.480519481
Kilogram/cubic meter	KG/M3	119.8264273

K-factor

Full Name	Abbr. Name	Multiplier
Pulse/gallon PULSE/GALLON		1
Pulse/liter PULSE	E/LITER	0.264172052
Pulse/ft3 PULSE/	FT3	7.480519481
Pulse/m3 PULSE/	M3	264.1720524

Appendix B: Units Of Measure

Time

Full Name	Abbr. Name	Multiplier
Second	SEC	1
Minute	MIN	
Hour	HR	
Day	DAY	

Appendix C: Error Messages

MESSAGE	COMMENTS	Error reported on trip report.	
1	TEMP SHORT	Temperature probe resistance input is less then 5 OHMS.	
2	TEMP OPEN	Temperature probe resistance input is more then 15K OHMS.	
3	PRESS FAIL	Pressure Analog signal input is not detected. The computed value of the analog input value is equal to zero volts.	
4	TEMP FAIL	Temperature signal analog input is not detected. The computed value of the analog input value is equal to zero volts.	
5	TEMP COMP	Temperature of the selected channel is out of range specified for analog input. It means the fluid temperature is out of accurate measurement range. This message will appear in normal operation during cool down and after the delivery is complete.	Yes
6	PRES COMP	Pressure is out of range specified for analog input. It means the fluid pressure is out of accurate measurement range. This message will appear in normal operation during cool down and after the delivery is complete.	Yes
7	PULSE FREQUENCY ERROR	Pulse error condition is detected in a dual coil system.	Yes
8	TWO PHASE WARNING	Pressure is between saturated pressure and 5 psia above the saturated pressure. It means that the liquid is approaching a point where it may contain bubbles, which will cause delivery error. It is normal to see this message while the meter is being cooled down.	
9	GAS INHIBIT	Pressure is equal or below the saturated pressure. It means there is no longer liquid in the meter run. It is normal to see this message before and during cool down and after the delivery has been completed. If it appears during a delivery, it is possible that the pump has lost prime.	Yes
10	FLOWMETER RUNNING	Displayed if the operator attempts to clear totals or make configuration changes while flow is present.	
11	CONFIG CHANGED RESET REQUIRED	Configuration parameters have been changed and saved. The unit must be reset for the changes to take effect.	
12	Min delivery error	This message is PRINTED on the delivery ticket only.	
13	Printer out of paper	No paper is detected in the printer.	
14	Printer off	Printer is off line.	
15	FLOW HH	Flow Rate has exceeded the limit defined in the High Flow limit field. This message may appear if the meter is being gas spun by cold gas. This can occur even if the delivery total is inhibited by the gas cutout feature.	Yes
16	FLOW LL	Flow Rate has exceeded the limit defined in the Low Flow limit field. It is normal to see this error message when cooling down and when switching over from recirculation to product delivery.	
17	COIL OPEN	Coil resistance is above the specified range	
18	COIL SHORT	Coil resistance is below the specified range	
19	BAD PULSE LIMIT EXCEEDED	“Bad Pulses” have exceeded the limit set for % of Total During Error.	

Appendix D: Reference Densities

Reference Densities for LIN, LOX, LAR and CO2 (Per NIST 2004)

Reference Condition	Fluid	Temp Deg C	Press PSIA	Press BAR-abs	Density LB/FT3	Density LB/GAL	Density KG/M3
NIST <i>21° C, 101.325 Kpas</i>	LIN	21.00	14.696	1.013	0.072470	0.009688	1.160858
	LOX	21.00	14.696	1.013	0.082820	0.011071	1.326649
	LAR	21.00	14.696	1.013	0.103390	0.013821	1.656149
	CO2	21.00	14.696	1.013	0.114430	0.015297	1.832993
OIML <i>15° C, 101.325 Kpas</i>	LIN	15.00	14.696	1.013	0.073984	0.009890	1.185110
	LOX	15.00	14.696	1.013	0.084550	0.011303	1.354361
	LAR	15.00	14.696	1.013	0.105550	0.014110	1.690749
	CO2	15.00	14.696	1.013	0.116860	0.015622	1.871918
PTB <i>15° C, 1 BAR</i>	LIN	15.00	14.504	1.000	0.073016	0.009761	1.169604
	LOX	15.00	14.504	1.000	0.083444	0.011155	1.336645
	LAR	15.00	14.504	1.000	0.104170	0.013926	1.668643
	CO2	15.00	14.504	1.000	0.115320	0.015416	1.847249
SIRIM <i>30° C, 101.325 Kpas</i>	LIN	30.00	14.696	1.013	0.070313	0.009400	1.126306
	LOX	30.00	14.696	1.013	0.080353	0.010742	1.287132
	LAR	30.00	14.696	1.013	0.100310	0.013410	1.606812
	CO2	30.00	14.696	1.013	0.110980	0.014836	1.777729
ASIAN <i>27° C, 101.325 Kpas</i>	LIN	27.00	14.696	1.013	0.071018	0.009494	1.137599
	LOX	27.00	14.696	1.013	0.081159	0.010849	1.300042
	LAR	27.00	14.696	1.013	0.101320	0.013545	1.622991
	CO2	27.00	14.696	1.013	0.112100	0.014986	1.795670
NBP (1 ATM)	LIN	-195.80	14.696	1.013	50.324	6.727363	806.113
	LOX	-182.97	14.696	1.013	71.243	9.523835	1141.203
	LAR	-185.85	14.696	1.013	87.113	11.645353	1395.416
	CO2	-78.40	14.696	1.013	N/A	N/A	N/A
NORMAL <i>0° C, 101.325 Kpas</i>	LIN	0.00	14.696	1.013	0.078059	0.010435	1.250385
	LOX	0.00	14.696	1.013	0.089212	0.011926	1.429039
	LAR	0.00	14.696	1.013	0.111370	0.014888	1.783976
	CO2	0.00	14.696	1.013	0.123410	0.016498	1.976839

Appendix E: Changing The Display Language

ENGLISH	CZECH	POLISH	GERMAN	FRENCH	SPANISH (MX)	PORTUGUESE (BR)
To change the displayed language:	Abyste změnil zobrazený jazyk:	Aby zmienić wyświetlany język:	Gehen Sie folgendermaßen vor, um die angezeigte Sprache zu Ändern:	Pour modifier la langue affichée	Par a cambiar el idioma mostrado:	Para alterar o idioma exibido:
MENU	MENU MENU		MENU	MENU MENU		MENU
SCROLL	KLAVESY PRO PRESUN	PRZEWIJANIA ROLL	TASTE	DEFILER	TECLAS CON FLECHA	ROLAGEM
ADVANCED SETTINGS	ROZSIRENA NASTAVENI	USTAWIENIA ZAAWANSOWANE	ERWEITERTE EINSTELLUNGEN	PARAMETRES AVANCES	CONFIGURACION AVANZADA	CONFIGURACOES AVANÇADAS
SELECT VYBRAT		WYBIERZ	AUSWAHL	SELECT	SEL	SELECIONAR
SCROLL	KLAVESY PRO PRESUN	PRZEWIJANIA ROLL	TASTE	DEFILER	TECLAS CON FLECHA	ROLAGEM
SYSTEM CONFIGURATION	KONFIGURACE SYSTEMU	KONFIG. SYST.	SYSTEMKONFIG	SYSTEME	CONFIG. DEL SISTEMA	CONFIGURACAO DO SISTEMA
SELECT VYBRAT		WYBIERZ	AUSWAHL	SELECT	SEL	SELECIONAR
UTILITY FUNCTIONS	POMOCNE FUNKCE	DZIALANIE PROGR. NARZ.	DIENSTPROGR. FUNKTIONEN	FONCTIONS UTILITAIRES	FUNCIONES DE UTILIDAD	FUNCOES UTILITARIAS
SELECT VYBRAT		WYBIERZ	AUSWAHL	SELECT	SEL	SELECIONAR
SCROLL	KLAVESY PRO PRESUN	PRZEWIJANIA ROLL	TASTE	DEFILER	TECLAS CON FLECHA	ROLAGEM
LANGUAGE JAZYK		JEZYK	SPRACHE	LANGUE	IDIOMA	IDIOMA
EDIT UPRAVIT		EDYTUJ	BEARB	MODIFIER	EDITAR	EDITAR
SCROLL	KLAVESY PRO PRESUN	PRZEWIJANIA ROLL	TASTE	DEFILER	TECLAS CON FLECHA	ROLAGEM
ACCEPT PRIJMOUT		AKCEPTUJ	ANNEHMEN	ACCERTER	ACEPTAR	ACEITAR
HOME DOMU		NA POCZ	HOME	ACCUEIL	INICIO	HOME
SAVE ULOZIT		ZAPISZ	SPAREN	SAUVEGARDER	SALVAR	SALVAR
RESET RESET		KASOWANIE	REINICIALIZAR	REAJUSTE	REINICIAR	REINICIALIZAR

Appendix F: Drawings

4

3

2

1

DWG NO.	ACE-325	SH 1	REV A
---------	---------	------	-------

REVISIONS

ZONE	REV	DESCRIPTION	DATE	APP
	A	REVISED PER ECP 553, REMOVED IR	090224	V.K.

D

D

C

C

ACE II FRONT PANEL

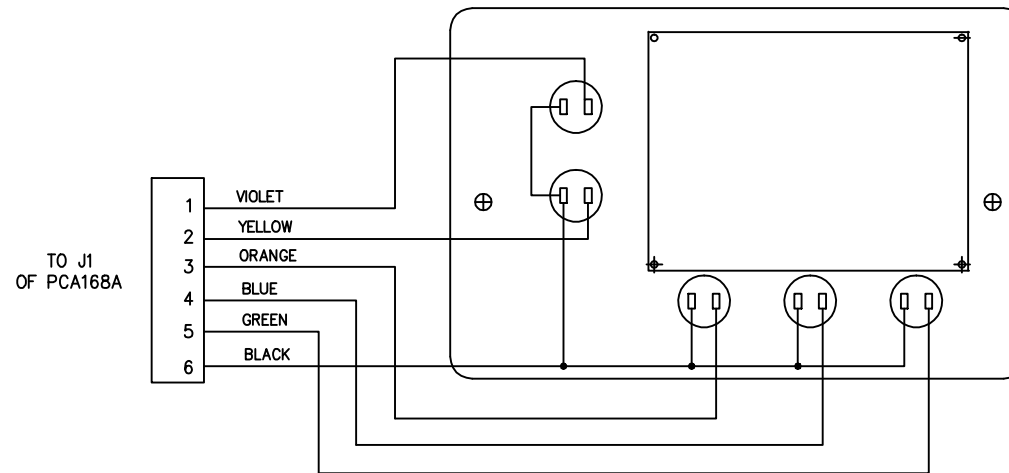
TO J1
OF PCA168A

B

B

A

A

		MATERIAL	DRAWN SWEET	DATE 020314	 H OFFER FLOW CONTROLS, INC ELIZABETH CITY, NC 27909												
			CHECK J.JERNIGAN	020314													
			PROJ ENG KRH	020314													
		FINISH			TITLE												
					FRONT PANEL WIRING, ACE II												
					<small>UNLESS OTHERWISE SPECIFIED DIMENSIONS ARE IN INCHES. TOLERANCES OTHER THAN THE SIZE OF RAW MATERIAL SHALL BE HELD AS FOLLOWS:</small> 2 PLACE DECIMALS ± .01 3 PLACE DECIMALS ± .005 FRACTIONAL ± 1/64 ANGULAR ± 1/2°												
	NEXT ASSY	USED ON			<small>CONFIDENTIAL PROPERTY OF HOFFER FLOW CONTROLS, INC. (HFC) NOT TO BE DISCLOSED TO OTHERS, REPRODUCED, OR USED FOR ANY OTHER PURPOSE, EXCEPT AS AUTHORIZED IN WRITING BY HFC. MUST BE RETURNED ON DEMAND, ON COMPLETION OF ORDER OR OTHER PURPOSE FOR WHICH LENT.</small>												
	APPLICATION				<table border="1"> <tr> <td>SIZE</td> <td>CAGE CODE</td> <td>DWG NO</td> <td>REV</td> </tr> <tr> <td>C</td> <td>33321</td> <td>ACE-325</td> <td>A</td> </tr> <tr> <td>SCALE</td> <td colspan="2">NONE</td> <td>SHEET 1 OF 1</td> </tr> </table>	SIZE	CAGE CODE	DWG NO	REV	C	33321	ACE-325	A	SCALE	NONE		SHEET 1 OF 1
SIZE	CAGE CODE	DWG NO	REV														
C	33321	ACE-325	A														
SCALE	NONE		SHEET 1 OF 1														

4

3

2

1

REVISIONS			
REV	DESCRIPTION	DATE	APP
A	PER ECP 500-11, ADDED 2 PIN HOUSING AND WIRING.	030627	V.K.
B	REVISED OER ECO 553, REMOVED IR	090224	V.K.

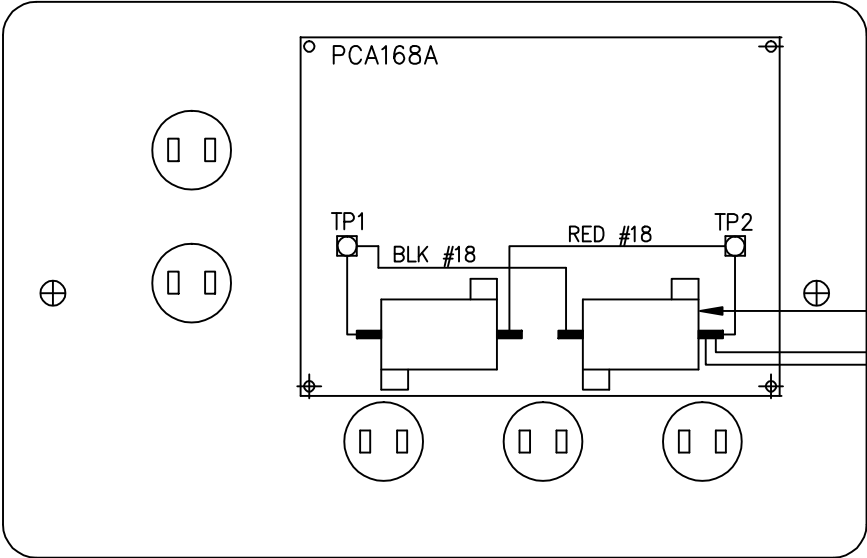

12V INPUT: 25 OHM 10W
STOCK # 100-0240 (2 PLACES)

24V INPUT: 100 OHM 10W
STOCK # 100-0241 (2 PLACES)

← RED 22 AWG
TWISTED PAIR
APPROX. 9" LONG

← 2 PIN HOUSING
STOCK # 100-0250

		MATERIAL	DRAWN SWEET	DATE 020313	 HOFFER FLOW CONTROLS, INC. ELIZABETH CITY, NC 27909
			CHECK J.JERNIGAN	020313	
		FINISH	PROJ ENG KRH	020314	
					TITLE
					FRONT PANEL, HEATER WIRING- ACE II
		CONFIDENTIAL PROPERTY OF HOFFER FLOW CONTROLS, INC. (HFC) NOT TO BE DISCLOSED TO OTHERS, REPRODUCED, OR USED FOR ANY OTHER PURPOSE, EXCEPT AS AUTHORIZED IN WRITING BY HFC. MUST BE RETURNED ON DEMAND, ON COMPLETION OF ORDER OR OTHER PURPOSE FOR WHICH LENT.	UNLESS OTHERWISE SPECIFIED DIMENSIONS ARE IN INCHES, TOLERANCES OTHER THAN RAW MATERIAL SHALL BE HELD AS FOLLOWS:		
			2 PLACE DECIMAL ±.01		SIZE A
			3 PLACE DECIMAL ±.005		CAGE CODE 33321
			FRACTIONAL ±1/64		DWG NO ACE-326
			ANGULAR ±1/2'		REV B
NEXT ASSY	USED ON				SCALE NONE
APPLICATION					SHEET 1 OF 1

NOTES:
 1. RELAY COIL VOLTAGE SHOULD BE THE SAME AS VDC IN. SPECIFY +12 OR +24V.
 2. 3-WIRE RTD, "TEMP. SHORT" IS DISPLAYED WHEN 2-WIRE CABLE IS CONNECTED.

REVISIONS				
ZONE	REV	DESCRIPTION	DATE	APP
	A	CORRECTED PRESSURE INPUT, ADDED 3rd WIRE FOR TEMPERATURE	040825	V.K
	B	REVISED PER ECP 500-31	080606	V.K
	C	ADDED OPTIONAL BLUE TOOTH CONNECTOR PER ECP 566	100331	JJ
	D	PER ECP 571, ADDED OPTION POWER SWITCH.	100930	JJ

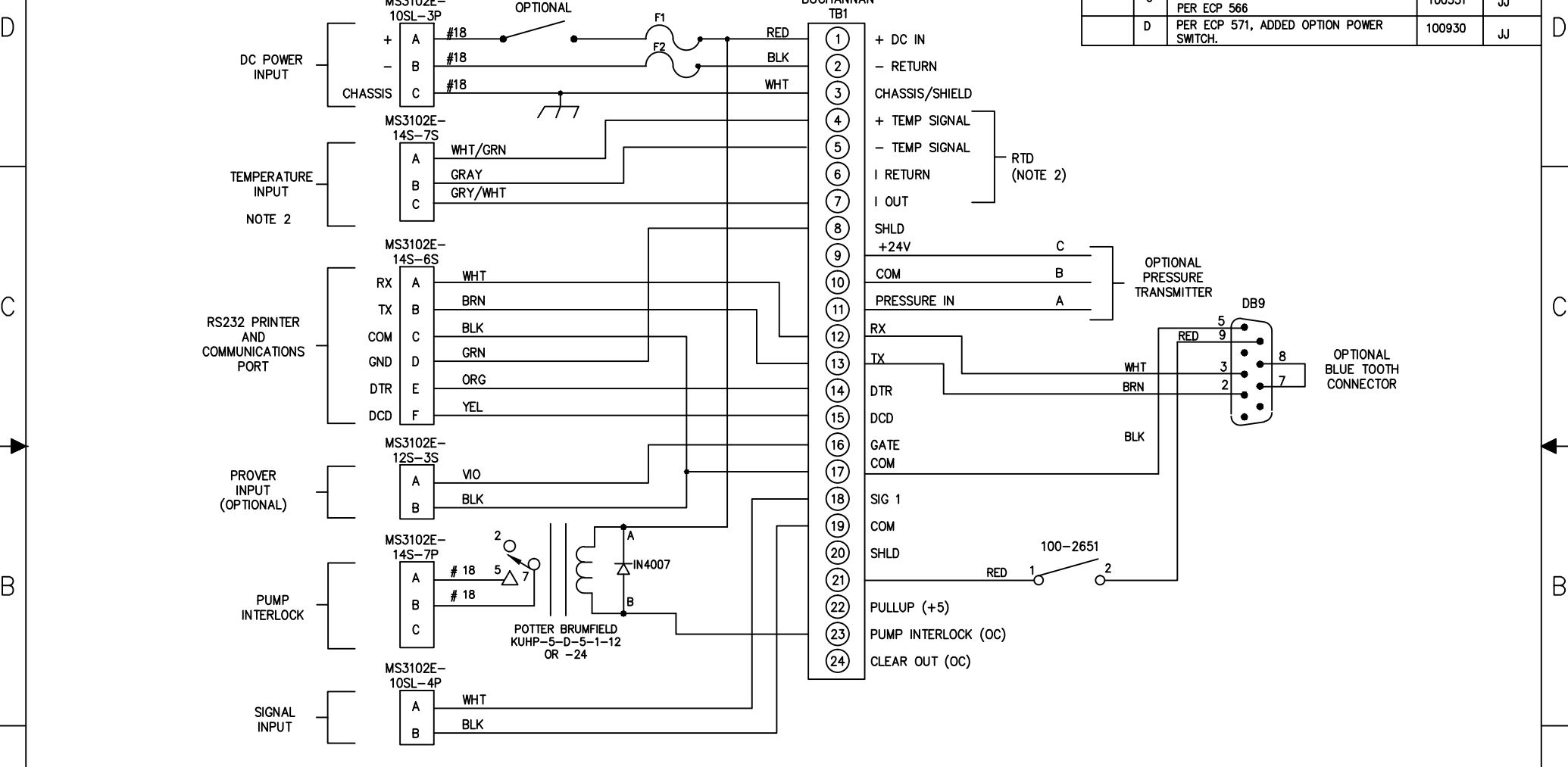

MATERIAL	DRAWN	SWEET	DATE
	CHECK	V.KEPKA	020717
	PROJ ENG	V.KEPKA	020717
FINISH			
<p>CONFIDENTIAL PROPERTY OF HOFFER FLOW CONTROLS, INC. (HFC) NOT TO BE DISCLOSED TO OTHERS, REPRODUCED, OR USED FOR ANY OTHER PURPOSE, EXCEPT AS AUTHORIZED IN WRITING BY HFC. MUST BE RETURNED ON DEMAND, ON COMPLETION OF ORDER OR OTHER PURPOSE FOR WHICH LENT.</p> <p>UNLESS OTHERWISE SPECIFIED DIMENSIONS ARE IN INCHES. TOLERANCES OTHER THAN THE SIZE OF RAW MATERIAL SHALL BE HELD AS FOLLOWS:</p> <p>2 PLACE DECIMALS ± .01 3 PLACE DECIMALS ± .005 FRACTIONAL ± 1/64 ANGULAR ± 1/2°</p>			
NEXT ASSY	USED ON		APPLICATION

H HOFFER FLOW CONTROLS, INC.
 ELIZABETH CITY, NC 27909

TITLE
 CASE WIRING-
 ACE II

SIZE	CAGE CODE	DWG NO	REV
C	33321	ACE-327	D
SCALE	NONE		SHEET 1 OF 1

REVISIONS				
ZONE	REV	DESCRIPTION	DATE	APP
	A	ADDED OPTIONAL PRESSURE, ADDED PUMP INTERLOCK	050518	JJ
	B	REVISED PER ECP 500-31	080606	V.K.
	C	ADDED OPTIONAL BLUE TOOTH CONN. PER ECP 566	100331	JJ
	D	PER ECP 571, ADDED OPTIONAL POWER SWITCH	100930	JJ

- NOTES:
 1. RELAY COIL VOLTAGE SHOULD BE THE SAME AS VDC IN. SPECIFY +12 OR +24V.
 2. 3-WIRE RTD, "TEMP. SHORT" IS DISPLAYED WHEN 2-WIRE CABLE IS CONNECTED.

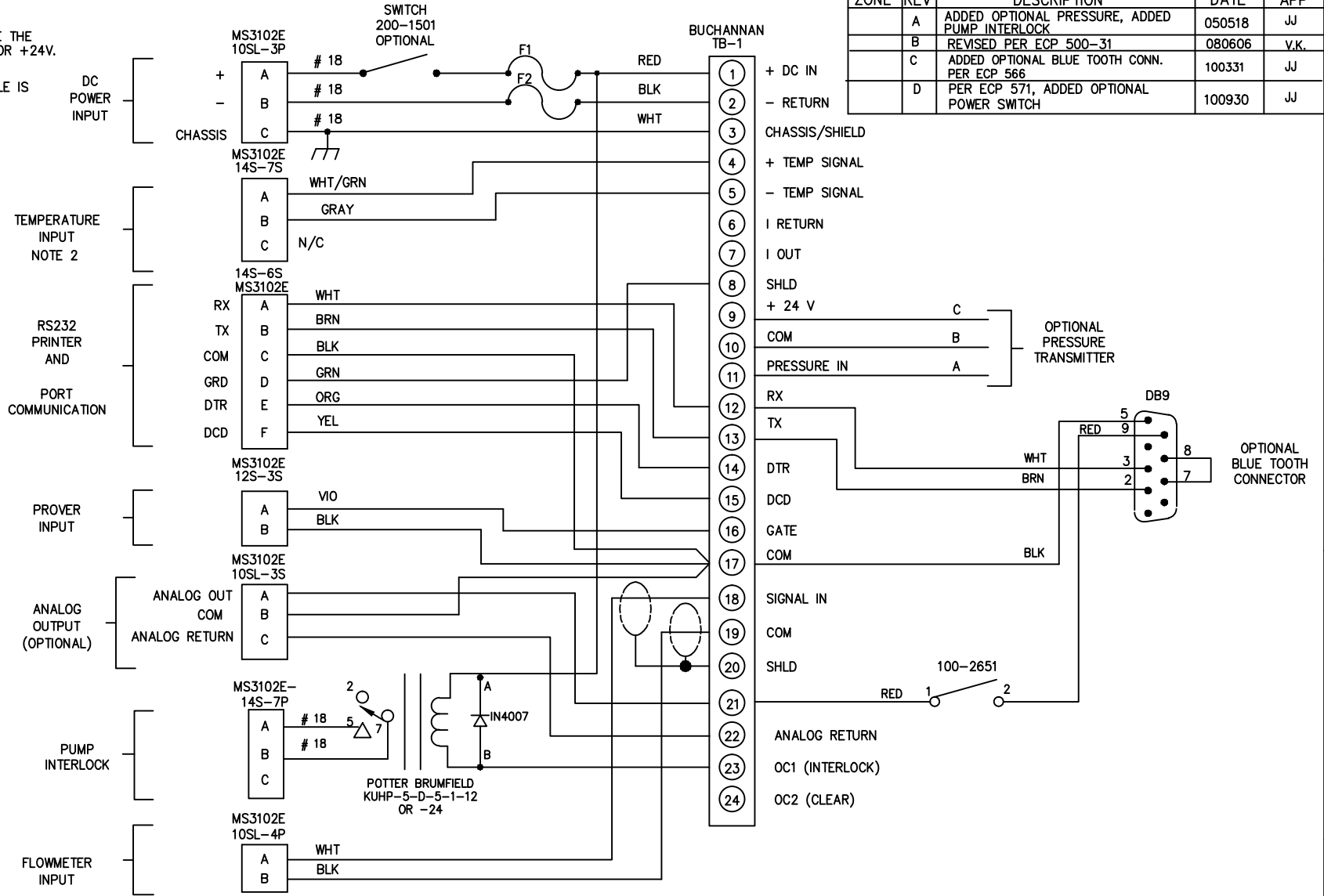

MATERIAL		DRAWN SWEET	DATE 020717
FINISH		CHECK V.KEPKA	020717
		PROJ ENG V.KEPKA	020717
NEXT ASSY	USED ON	UNLESS OTHERWISE SPECIFIED DIMENSIONS ARE IN INCHES. TOLERANCES OTHER THAN THE SIZE OF RAW MATERIAL SHALL BE HELD AS FOLLOWS: 2 PLACE DECIMALS ± .01 3 PLACE DECIMALS ± .005 FRACTIONAL ± 1/64 ANGULAR ± 1/2	
APPLICATION			

H HOFFER FLOW CONTROLS, INC
 ELIZABETH CITY, NC 27909

ACEII CASE WIRING,
 ANALOG OUTPUT

SIZE C	CAGE CODE 33321	DWG NO. ACE-328	REV D
SCALE NONE	SHEET 1 OF 1		

DWG NO.	ACE-942	SH 1	REV A	1
REVISIONS				
ZONE	REV	DESCRIPTION	DATE	APP
	A	REVISED PER ECP 553, REMOVED IR	090224	V.K.

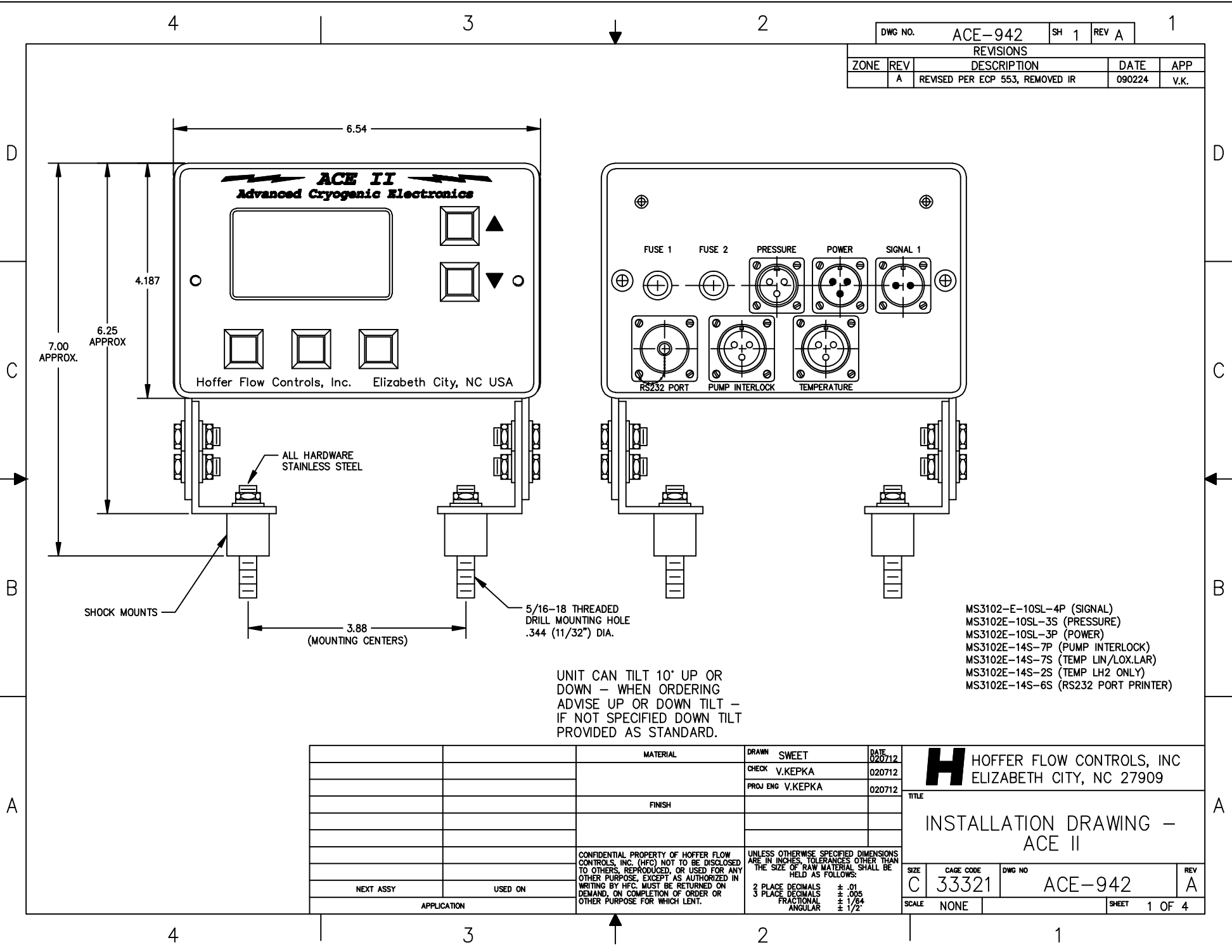

- MS3102-E-10SL-4P (SIGNAL)
- MS3102E-10SL-3S (PRESSURE)
- MS3102E-10SL-3P (POWER)
- MS3102E-14S-7P (PUMP INTERLOCK)
- MS3102E-14S-7S (TEMP LIN/LOX.LAR)
- MS3102E-14S-2S (TEMP LH2 ONLY)
- MS3102E-14S-6S (RS232 PORT PRINTER)

UNIT CAN TILT 10° UP OR DOWN - WHEN ORDERING ADVISE UP OR DOWN TILT - IF NOT SPECIFIED DOWN TILT PROVIDED AS STANDARD.

		MATERIAL	DRAWN SWEET	DATE 020712
			CHECK V.KEPKA	020712
			PROJ ENG V.KEPKA	020712
		FINISH		
NEXT ASSY	USED ON			
APPLICATION				
		CONFIDENTIAL PROPERTY OF HOFFER FLOW CONTROLS, INC. (HFC) NOT TO BE DISCLOSED TO OTHERS, REPRODUCED, OR USED FOR ANY OTHER PURPOSE, EXCEPT AS AUTHORIZED IN WRITING BY HFC. MUST BE RETURNED ON DEMAND, ON COMPLETION OF ORDER OR OTHER PURPOSE FOR WHICH LENT.	UNLESS OTHERWISE SPECIFIED DIMENSIONS ARE IN INCHES. TOLERANCES OTHER THAN THE SIZE OF RAW MATERIAL SHALL BE HELD AS FOLLOWS: 2 PLACE DECIMALS ± .01 3 PLACE DECIMALS ± .005 FRACTIONAL ± 1/64 ANGULAR ± 1/2°	

H HOFFER FLOW CONTROLS, INC
ELIZABETH CITY, NC 27909

TITLE
INSTALLATION DRAWING - ACE II

SIZE C	CAGE CODE 33321	DWG NO ACE-942	REV A
SCALE NONE	SHEET 1 OF 4		

DWG NO.		ACE-942	SH 2	REV A	1
REVISIONS					
ZONE	REV	DESCRIPTION	DATE	APP	

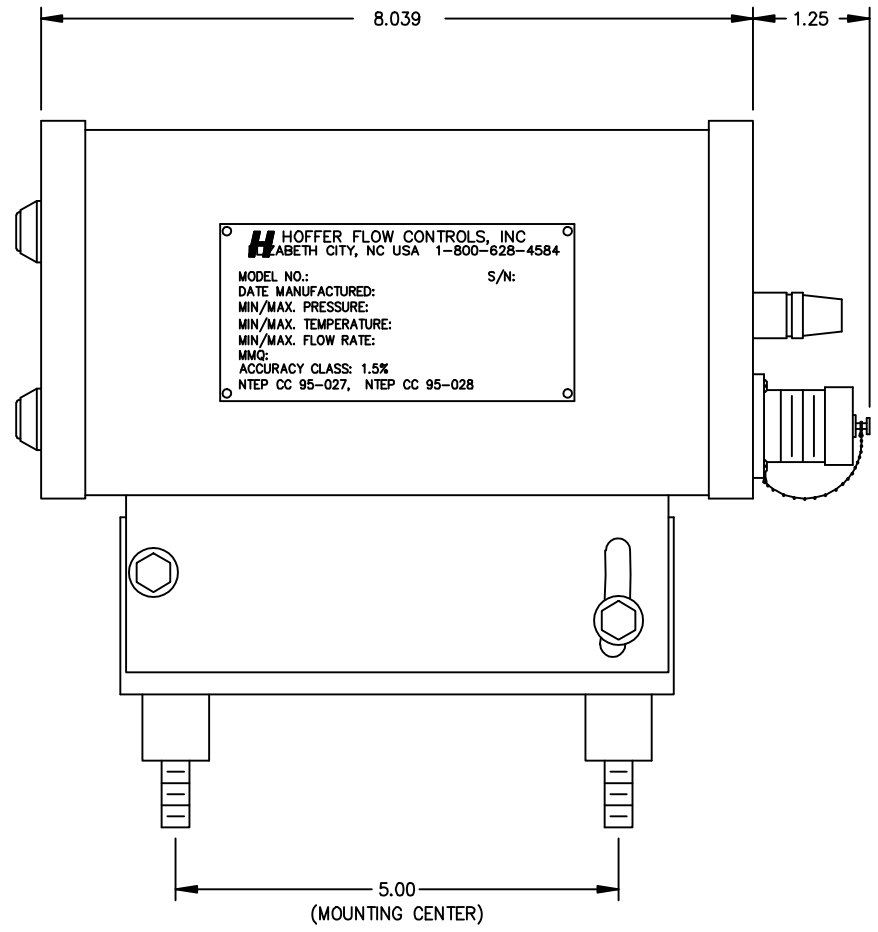

H HOFFER FLOW CONTROLS, INC
 WELLSBORO, NC USA 1-800-628-4584
 MODEL NO.: S/N:
 DATE MANUFACTURED:
 MIN/MAX. PRESSURE:
 MIN/MAX. TEMPERATURE:
 MIN/MAX. FLOW RATE:
 MMG:
 ACCURACY CLASS: 1.5%
 NTEP CC 95-027, NTEP CC 95-028

NOTE:
ALLOW AN ADDITIONAL 4" MINIMUM
BEHIND UNIT FOR MATING CONNECTORS
AND CABLES.

ACE INSTALLATION
SIDE VIEW

DRAWN	SWEET	SIZE	C	CAGE CODE	33321	DWG NO.	ACE-942	REV	A
CHECKED	V.KEPKA	SCALE	NONE	SHEET		2 OF 4			

DWG NO. ACE-942 SH 3 REV A

REVISIONS				
ZONE	REV	DESCRIPTION	DATE	APP

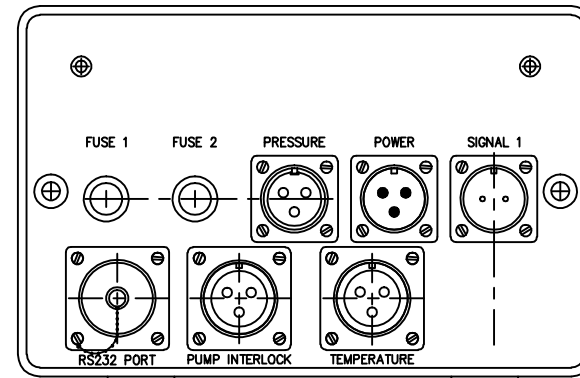
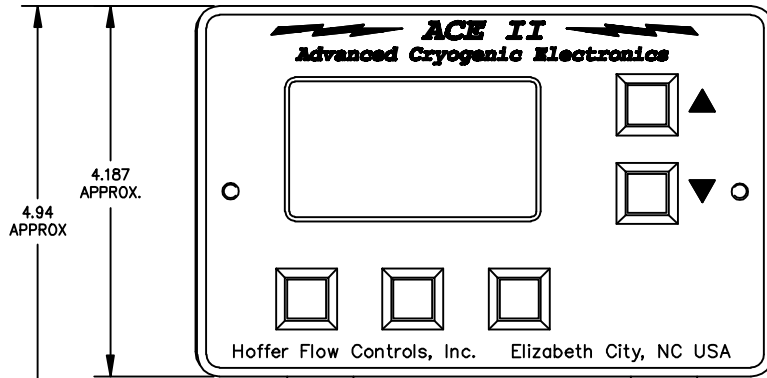

SHOCK MOUNTS

3.88
(MOUNTING CENTERS)

5/16-18 THREADED
DRILL MOUNTING HOLE
.344 (11/32") DIA.

- MS3102-E-10SL-4P (SIGNAL)
- MS3102E-10SL-3S (PRESSURE)
- MS3102E-10SL-3P (POWER)
- MS3102E-14S-7P (PUMP INTERLOCK)
- MS3102E-14S-7S (TEMP LIN/LOX.LAR)
- MS3102E-14S-2S (TEMP LH2 ONLY)
- MS3102E-14S-6S (RS232 PORT PRINTER)

ACE INSTALLATION
FRONT AND REAR VIEWS

DRAWN SWEET	SIZE C	CAGE CODE 33321	DWG NO ACE-942	REV A
CHECKED V.KEPKA	SCALE NONE	SHEET 3 OF 4		

DWG NO. ACE-942 SH 4 REV A 1

REVISIONS				
ZONE	REV	DESCRIPTION	DATE	APP

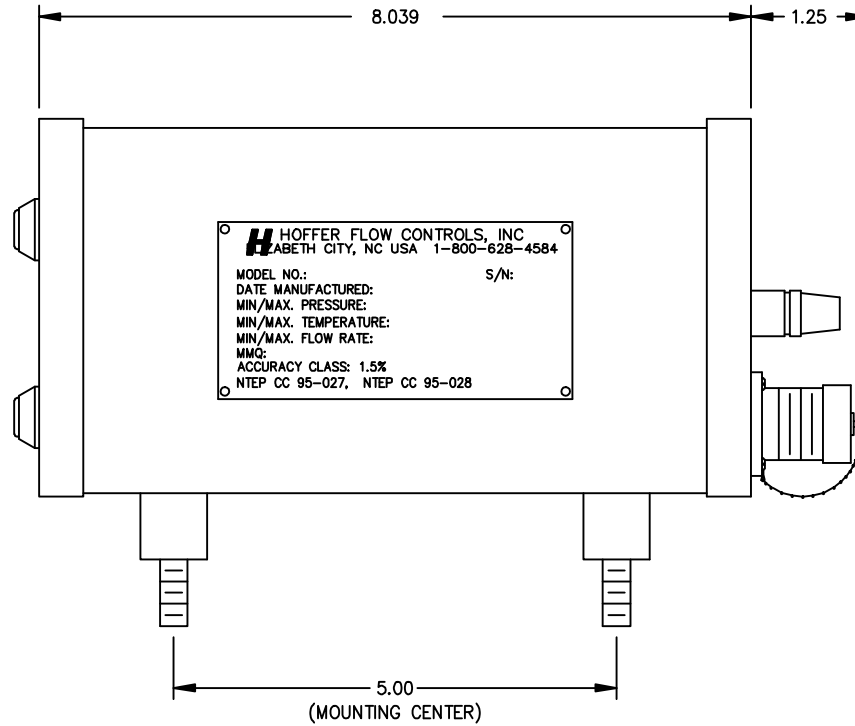

NOTE:
ALLOW AN ADDITIONAL 4" MINIMUM
BEHIND UNIT FOR MATING CONNECTORS
AND CABLES.

ACE INSTALLATION
SIDE VIEW

DRAWN SWEET	SIZE C	CAGE CODE 33321	DWG NO. ACE-942	REV A
CHECKED V.KEPKA	SCALE NONE	SHEET 4 OF 4		