

F0-04AD-1 4-Channel Analog Current Input

In This Chapter. . . .

- Module Specifications
 - Setting the Module Jumper
 - Connecting and Disconnecting the Field Wiring
 - Wiring Diagram
 - Module Operation
 - Special V-memory Locations
 - Using the Pointer in Your Control Program
 - Detecting Input Signal Loss
 - Scale Conversions
 - Special Relays
-

Module Specifications

The F0-04AD-1 Analog Input module offers the following features:

- The DL05 reads all four channels in one scan.
- The removable terminal block makes it possible to remove the module without disconnecting the field wiring.
- Analog inputs can be used as process variables for the (4) PID loops included in the DL05 CPU.
- Field device burn-out is detected on all four channels when 4–20mA range is selected.
- On-board active analog filtering and RISC-like microcontroller provide digital signal processing to maintain precise analog measurements in noisy environments.



NOTE: The DL05 CPU's analog feature requires *DirectSOFT32* Version 3.0c (or later) and firmware version 2.1 (or later). See our website for more information: www.automationdirect.com.



The following tables provide the specifications for the F0-04AD-1 Analog Input Module. Review these specifications to make sure the module meets your application requirements.

Input Specifications

Number of Channels	4, single ended (one common)
Input Range	0 to 20 mA or 4 to 20 mA current (jumper selectable)
Resolution	12 bit (1 in 4096) for 0-20mA, scaled for 4-20mA
Step Response	25.0 mS (typ) to 95% of full step change
Crosstalk	-80 dB, 1/2 count maximum *
Active Low-pass Filtering	-3 dB at 40Hz (-12 dB per octave)
Input Impedance	125 Ohm \pm 0.1%, 1/8 W current input
Absolute Maximum Ratings	-30 mA to +30 mA, current input
Converter type	Successive approximation
Linearity Error (End to End)	\pm 1 count (0.025% of full scale) maximum *
Input Stability	\pm 1 count *
Full Scale Calibration Error (Offset error not included)	\pm 10 counts maximum, @ 20mA current input *
Offset Calibration Error	\pm 5 counts maximum, @ 4mA current input *
Maximum Inaccuracy	\pm .4% @ 25°C (77°F) \pm .85% 0 to 60°C (32 to 140°F)
Accuracy vs. Temperature	\pm 80 ppm/°C maximum full scale calibration (including maximum offset change)
Recommended Fuse (external)	0.032 A, Series 217 fast-acting, current inputs

* One count in the specification table is equal to one least significant bit of the analog data value (1 in 4096).

General Specifications

PLC Update Rate	4 channels per scan
16-bit Data Word	12 binary data bits, 2 channel ID bits, 2 diagnostic bits
Operating Temperature	0 to 60° C (32 to 140° F)
Storage Temperature	-20 to 70° C (-4 to 158° F)
Relative Humidity	5 to 95% (non-condensing)
Environmental air	No corrosive gases permitted
Vibration	MIL STD 810C 514.2
Shock	MIL STD 810C 516.2
Noise Immunity	NEMA ICS3-304

Setting the Module Jumper

The position of jumper J3 determines the input signal level. You can choose between 4–20mA and 0–20mA. The module ships with the jumper *not* connecting the two pins. In this position, the expected input signal is 4–20mA. To select 0–20mA signals, use the jumper to cover both pins.

The default jumper setting selects a 4–20mA signal source. The default jumper setting does *not* connect the two pins.

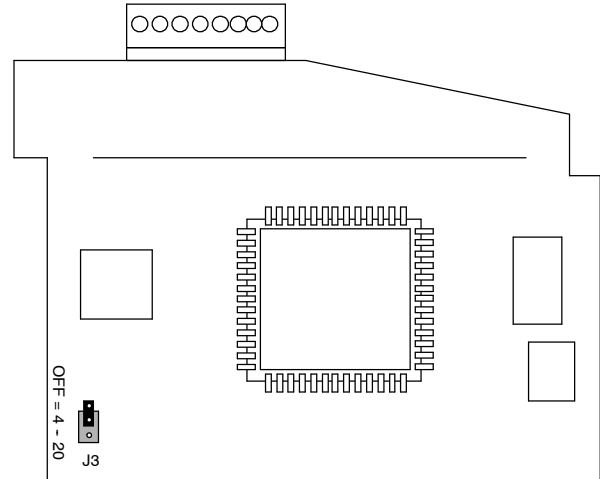

WARNING: Before removing the analog module or the terminal block on the face of the module, **disconnect power** to the **PLC** and **all field devices**. Failure to disconnect power can result in damage to the PLC and/or field devices.

Connecting and Disconnecting the Field Wiring

Wiring Guidelines Your company may have guidelines for wiring and cable installation. If so, you should check those before you begin the installation. Here are some general things to consider:

- Use the shortest wiring route whenever possible.
- Use shielded wiring and ground the shield at the transmitter source. *Do not* ground the shield at both the module and the source.
- Do not run the signal wiring next to large motors, high current switches, or transformers. This may cause noise problems.
- Route the wiring through an approved cable housing to minimize the risk of accidental damage. Check local and national codes to choose the correct method for your application.

The F0-04AD-1 does not supply power to field devices. You will need to power transmitters separately from the PLC.

To remove the terminal block, disconnect power to the PLC and the field devices. Pull the terminal block firmly until the connector separates from the module.

You can remove the analog module from the PLC by folding out the retaining tabs at the top and bottom of the module. As the retaining tabs pivot upward and outward, the module's connector is lifted out of the DL05 socket. Once the connector is free, you can lift the module out of its slot.

Wiring Diagram

Use the following diagram to connect the field wiring. If necessary, the F0-04AD-1 terminal block can be removed to make removal of the module possible without disturbing field wiring.

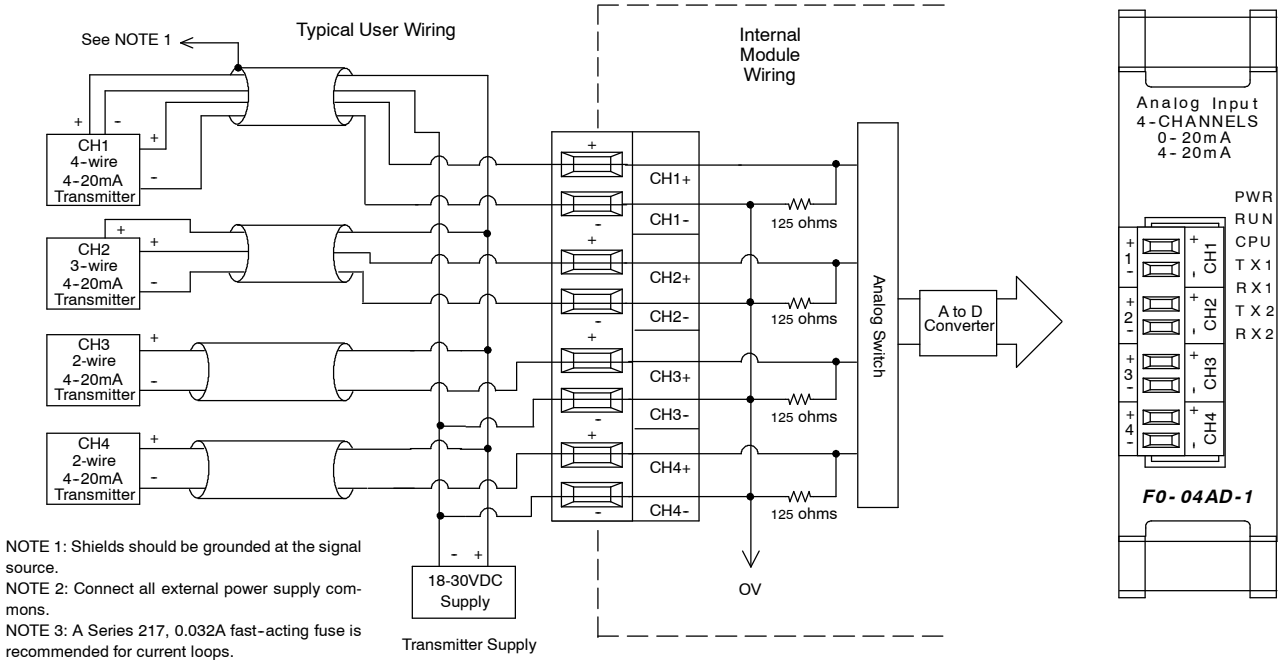

Current Loop Transmitter Impedance

Manufacturers of transmitters and transducers specify a wide variety of power sources for their products. Follow the manufacturer's recommendations.

In some cases, manufacturers specify a minimum loop or load resistance that must be used with the transmitter. The F0-04AD-1 provides 125 ohm resistance for each channel. If your transmitter requires a load resistance below 125 ohms, you do not have to make any changes. However, if your transmitter requires a load resistance higher than 125 ohms, you need to add a resistor in series with the module.

Consider the following example for a transmitter being operated from a 30 VDC supply with a recommended load resistance of 750 ohms. Since the module has a 125 ohm resistor, you need to add an additional resistor.

R	Tr	Mr	R = resistor to add
R	750	125	Tr = Transmitter Requirement
R	625		Mr = Module resistance (internal 125 ohms)

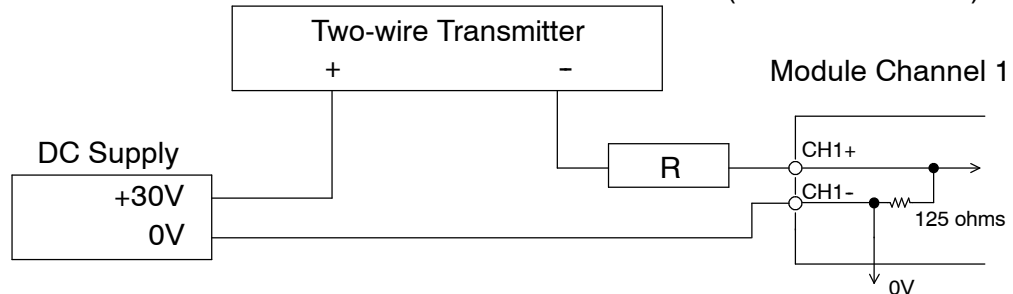

Module Operation

Channel Scanning Sequence with a DL05

The DL05 reads all four channels of input data during each scan. The CPU supports special V-memory locations that are used to manage the data transfer. This is discussed in more detail in the section on Writing the Control Program.

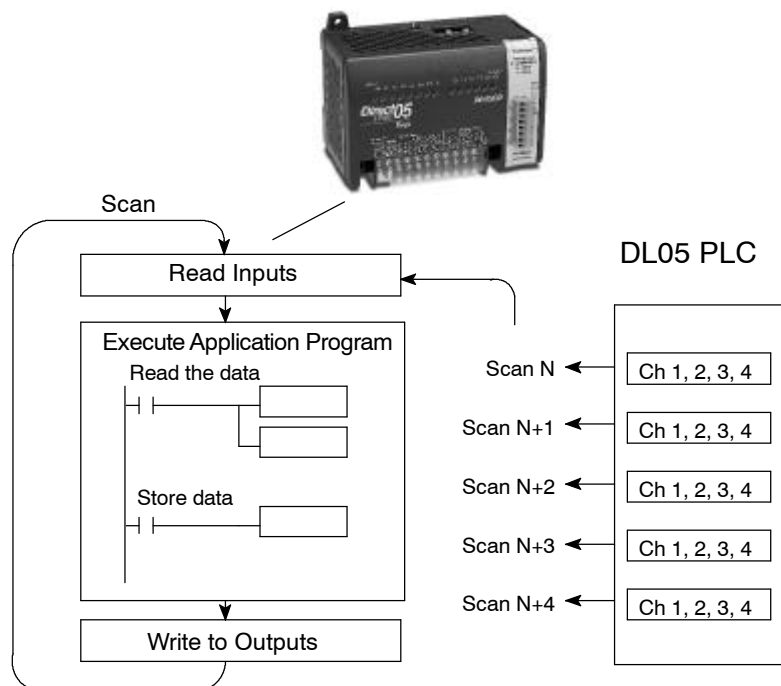

Analog Module Updates

Even though the channel updates to the CPU are synchronous with the CPU scan, the module asynchronously monitors the analog transmitter signals and converts each signal into a 12-bit binary representation. This enables the module to continuously provide accurate measurements without slowing down the discrete control logic in the RLL program.

The module takes approximately 25 milliseconds to sense 95% of the change in the analog signal. For the vast majority of applications, the process changes are much slower than these updates.



NOTE: If you are comparing other manufacturers' update times (step responses) with ours, please be aware that some manufacturers refer to the time it takes to convert the analog signal to a digital value. Our analog to digital conversion takes only a few microseconds. It is the settling time of the filter that is critical in determining the full "update time." Our update time specification includes the filter settling time.

Special V-memory Locations

Data Formatting

The DL05 series has two special V-memory locations assigned to the analog input module. These V-memory locations allow you to:

- specify the data format (binary or BCD)
- specify the number of channels to scan (4 channels for the F0-04AD-1)
- specify the V-memory locations to store the input data

The table below shows the special V-memory locations used by the DL05 PLC for analog input modules.

Analog Input Module V-memory Locations	
Data Type and Number of Channels	V7700
Storage Pointer	V7701

Structure of V7700

The DL05 PLC allows the use of bits 8 - 15 for identifying the number of input channels and the data type (binary or BCD). The F0-04AD-1 module actually uses only bits 10 and 15, as shown in the diagram below. Bit 10 identifies the module as a 4 channel analog input module. This bit should be set to 1 for the F0-04AD-1 module. Bit 15 is used to distinguish BCD (= 0) and binary (= 1).

Loading a constant of 0400h into V7700 puts a "1" in bit 10. This identifies a 4 channel analog input module in the DL05 option slot, and stores the input data values as BCD numbers.

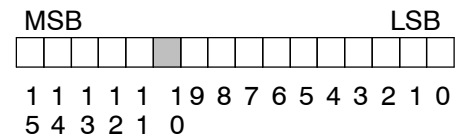

Loading a constant of 8400h into V7700 puts a "1" in bit 15 and bit 10. This identifies a 4 channel analog input module in the DL05 option slot, and stores the input values as binary numbers.

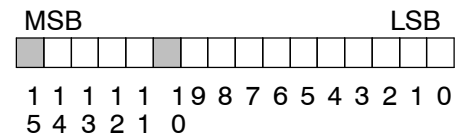

Structure of V7701

The DL05 PLC uses V7701 as a pointer to a V-memory location used for storing analog input data. The value loaded in V7701 is an octal number identifying the first word in a contiguous range of V-memory locations. For the F0-04AD-1 module, you will identify the first of four V-memory locations since it is a 4 channel module. For example, loading O2000 causes the pointer to write channel 1's data value to V2000, channel 2's data value to V2001, channel 3's data value to V2002, and channel 4's data value to V2003.

You will find an example program that loads appropriate values to V7700 and V7701 on page 10-9.

Analog Data Bits

The first twelve bits represent the analog data in binary format.

Bit	Value	Bit	Value
0	1	6	64
1	2	7	128
2	4	8	256
3	8	9	512
4	16	10	1024
5	32	11	2048



Module Resolution

Since the module has 12-bit resolution, the analog signal is converted into 4096 counts ranging from 0 - 4095 (2^{12}). For example, a 4mA signal would be 0 and a 20mA signal would be 4095. This is equivalent to a binary value of 0000 0000 0000 to 1111 1111 1111, or 000 to FFF hexadecimal. The diagram to the right shows how this relates to the signal range.

Each count can also be expressed in terms of the signal level by using the equation shown.

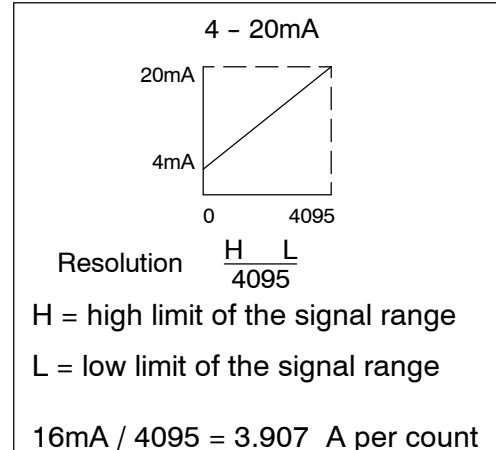

Using the Pointer in Your Control Program

Using the program below, the CPU examines the pointer values (the beginning memory location identified in V7701) on the first scan only.

The example program below shows how to setup these locations. Place this rung anywhere in the ladder program or in the initial stage if you are using stage programming instructions.

This is all that is required to read the analog input data into V-memory locations. Once the data is in V-memory you can perform math on the data, compare the data against preset values, and so forth. V2000 is used in the example but you can use any user V-memory location.

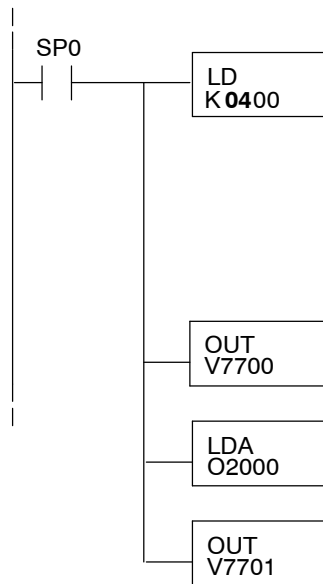

- or - LD
K8400

Loads a constant that specifies the number of channels to scan and the data format. The upper byte selects the data format (i.e. 0=BCD, 8=Binary) and the number of channels (set to 4 for the F0-01AD-1). The binary format is used for displaying data on some operator interfaces. The DL05 PLCs support binary math functions.

Special V-memory location assigned to the expansion slot contains the data format and the number of channels to scan.

This loads an octal value for the first V-memory location that will be used to store the incoming data. For example, the O2000 entered here would designate the following addresses.

Ch1 - V2000, Ch2 - V2001, Ch3 - V2002, Ch 4 - V2003

The octal address (O2000) is stored here. V7701 is assigned to the expansion slot and acts as a pointer, which means the CPU will use the octal value in this location to determine exactly where to store the incoming data.

Detecting Input Signal Loss

Analog Signal Loss

The F0-04AD-1 analog module can sense the loss of analog input signals in 4-20mA loops. The Special Relays described on page 10-12 allow you to use this feature in your ladder program. For example, in the rung below SP610 is used to pull-in coil Y1, which would be used to open or close an external circuit.



The Special Relay SP610 detects a loss of input signal to channel 1. Use SP610 to trigger an alarm or shut down a machine.



NOTE: The F0-04AD-1 analog module cannot sense the loss of analog input signals in 0-20mA loops. See page for information about setting the jumper to select your input type.

Scale Conversions

Scaling the Input Data

Many applications call for measurements in engineering units, which can be more meaningful than raw data. Convert to engineering units using the formula shown to the right.

You may have to make adjustments to the formula depending on the scale you choose for the engineering units.

$$\text{Units} = A \frac{H - L}{4095}$$

H = High limit of the engineering unit range

L = Low limit of the engineering unit range

A = Analog value (0 - 4095)

For example, if you wanted to measure pressure (PSI) from 0.0 to 99.9 then you would have to multiply the analog value by 10 in order to imply a decimal place when you view the value with the programming software or a handheld programmer. Notice how the calculations differ when you use the multiplier.

Analog Value of 2024, slightly less than half scale, should yield 49.4 PSI

Example without multiplier

$$\text{Units} = A \frac{H - L}{4095}$$

$$\text{Units} = 2024 \frac{100 - 0}{4095}$$

Units 49

Handheld Display

V 2001	V 2000
0000	0049

Example with multiplier

$$\text{Units} = 10 A \frac{H - L}{4095}$$

$$\text{Units} = 20240 \frac{100 - 0}{4095}$$

Units 494

Handheld Display

V 2001	V 2000
0000	0494

This value is more accurate

The Conversion Program

The following example shows how you would write the program to perform the engineering unit conversion. This example assumes you have BCD data loaded into the appropriate V-memory locations using instructions that apply for the model of CPU you are using.

Note: this example uses SP1, which is always on. You could also use an X, C, etc. permissive contact.

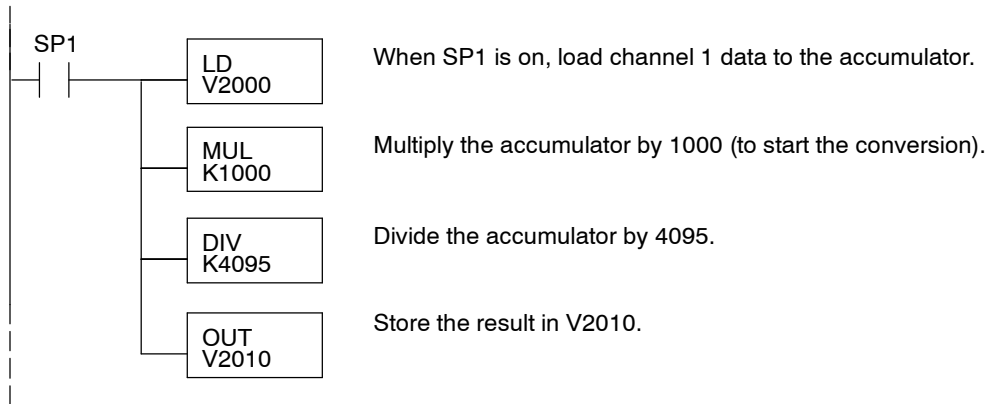

Analog and Digital Value Conversions

Sometimes it is useful to convert between the signal levels and the digital values. This is especially helpful during machine startup or troubleshooting. The following table provides formulas to make this conversion easier.

Range	If you know the digital value...	If you know the analog signal level...
4 to 20mA	$A = \frac{16D}{4095} - 4$	$D = \frac{4095}{16}(A + 4)$
0 to 20mA	$A = \frac{20D}{4095}$	$D = \frac{4095}{20}A$

For example, if you have measured the signal as 10mA, you can use the formula to determine the digital value that will be stored in the V-memory location that contains the data.

$$D = \frac{4095}{16}(A + 4)$$

$$D = \frac{4095}{16}(10\text{mA} - 4)$$

$$D = (255.93) (6) \quad D = 1536$$

Special Relays

The list of other Special Relays associated with the DL05 PLC is contained in the DL05 User Manual. The following special relays are new and relate to the status of the F0-04AD-1 module or one of its input channels.

SP600	Chan 1 input type	0 = 0 - 20mA	1 = 4 - 20mA
SP601	Chan 2 input type	0 = 0 - 20mA	1 = 4 - 20mA
SP602	Chan 3 input type	0 = 0 - 20mA	1 = 4 - 20mA
SP603	Chan 4 input type	0 = 0 - 20mA	1 = 4 - 20mA
SP610	Chan 1 input open	0 = xmitter signal open	1 = xmitter signal good
SP611	Chan 2 input open	0 = xmitter signal open	1 = xmitter signal good
SP612	Chan 3 input open	0 = xmitter signal open	1 = xmitter signal good
SP613	Chan 4 input open	0 = xmitter signal open	1 = xmitter signal good