

**USER MANUAL**  
**REFRIGERANT RECOVERY UNIT**

**RECO25 SERIES**

**TABLE OF CONTENTS**

GENERAL SAFETY GUIDELINES .....	2
SPECIFICATIONS .....	4
STANDARD LIQUID/VAPOR RECOVERY PROCEDURE .	5
SELF-PURGE PROCEDURE .....	7
LIQUID PUSH/PULL PROCEDURE.....	8
TANK COOLING PROCEDURE (OPTIONAL) .....	9
ALTERNATIVE COOLING PROCEDURE(OPTIONAL) .....	10
OIL SEPARATING PROCEDURE .....	11
TROUBLESHOOTING.....	12
WIRING DIAGRAM .....	13
PARTS DIAGRAM .....	14

## GENERAL SAFETY GUIDELINES

1. Read all safety, operating guidelines and instructions before operating this recovery machine.
2. Always think before acting, familiarity breeds carelessness, and carelessness can be harmful to your health, or worse, result in death.
3. Only a qualified technician should operate this Recovery machine.
4. Read all safety information regarding the safe handling of refrigerant and refrigerant oil, including the Material Safety Data Sheet. MSDS sheets can be obtained from your refrigerant supplier.
5. Always wear safety goggles and protective gloves when working with refrigerants to protect your skins and eyes from refrigerant gases and refrigerant liquid. Avoid getting in touch with causticity liquid or gas.
6. Be sure that any room where you are working is thoroughly ventilated.
7. Use ONLY authorized refillable refrigerant tanks. It requires the use of recovering tanks with a minimum of 27.6 bar working pressure.
8. Do not overfill the storage tank. Tank is full at 80% volume. There should be enough space for liquid expansion—overfilling of the tank may cause a violent explosion. A scale or a 80% O.F.P. Kit must be used to avoid over filling the storage tank.
9. Do not exceed the working pressure of Recovering Tank cylinder.
10. Do not mix different refrigerants together in one tank, or they could not be separated or used.
11. Before recovering the refrigerant, the tank should achieve the vacuum level: -0.1 mpa, which is for purging non-condensable gases.  
Each tank was full of nitrogen when it was manufactured in the factory, thus the nitrogen should be evacuated before the first use.
12. When the recovery machine is not used, all the valves should be closed. Because the air or the moisture of the air may harm the recovery result and shorten the service life of the recovery machine.
13. When using an extension cord, it should be a 14AWG minimum and no longer than 7.62 meters (25feet), or it may make the voltage drop and damage the compressor.

## **GENERAL SAFETY GUIDELINES**

14. A dry filter must always be used and should be replaced frequently. And each type of refrigerant must have its own filter. For the sake of assuring the normal operation of the unit, please use the filter specified by our company. High quality dry filters will bring high quality services.

15. Special care should be taken when recovering from a "burned-out" system. Use two high acid capacity filters, in series. When you have finished recovering from the system, flush the recovery machine with a small amount of clean refrigerant and refrigerant oil to purge off any foreign substances left in the machine.

16. This recovery machine has a Pressure Shut Off Switch. If the pressure inside the system should go above 38bars, the system will automatically shut itself off. The shut off switch must be manually reset.

17. If the tank pressure exceeds 20.7bar, use the TANK COOLING PROCEDURE to reduce the tank pressure.

18. To maximize recovery rates, use the shortest possible length of 3/8" or larger hose. A hose no longer than 0.9 meter is recommended.

19. When recovering large amounts of liquid, use the LIQUID PUSH/PULL PROCEDURE.

20. After recovering, make sure there's no refrigerant left in the machine. Read the SELF-PURGING PROCEDURE carefully.

Liquid refrigerant remained may be expanded and destroy the components.

21. If this recovery machine is to be stored or not used for any length of time, we recommend that it be completely evacuated of any residual refrigerant and purged with dry nitrogen.

22. To reduce the risk of injury, care should be taken when moving this machine.

## SPECIFICATIONS

<b>Refrigerants</b>	Cat. III: R-12, R-134a, R-401C, R-406A, R-500 Cat. IV: R-22, R-401A, R-401B, R-402B, R-407C, R-407D, R-408A, R-409A, R-411A, R-411B, R-412A, R-502, R-509 Cat. V: R-402A, R-404A, R-407A, R-407B, R-410A, R-507		
<b>Voltage</b>	220-240VAC 50/60Hz	110-127VAC 60Hz	
	100VAC 50/60Hz	110/220VAC 50/60Hz	
<b>Compressor</b>	1/2 HP Oil-less		
<b>Max current</b>	4A @ 50Hz	8A @ 60Hz	
<b>HP Shut-off</b>	38bar/550psi		
<b>Recovery Rate</b>	Cat. III	Cat. IV	Cat. V
Vapor	0.23kg/min	0.25kg/min	0,26kg/min
Liquid	1.57kg/min	1.81kg/min	1.85kg/min
Push/Pull	4.64kg/min	5.57kg/min	6.22kg/min
<b>LP Shut-off</b>	Optional		
<b>80% Capacity Shut-off</b>	Optional		
<b>Operating Temp.</b>	0-40°C		
<b>Case</b>	Blow Molded High Impact Polyethylene		
<b>Dimensions</b>	19.1" L x 8.7" W x 14.4" H (485mm x 220mm x 365mm)		
<b>Net Weight</b>	33 lbs (15kg)		

## STANDARD LIQUID/VAPOR RECOVERY PROCEDURE

1. Make sure this recovery machine is in good operating condition.
2. Make sure all connections are correct and tight.
3. Open the liquid port of the storage tank.
4. Make sure the MODE valve is set on RECOVER.
5. Open the output port of the recovery machine.
6. Open the liquid port on your manifold gauge set; opening the liquid port will remove the liquid from the system first. After the liquid has been removed, open the manifold vapor port to finish evacuating the system.

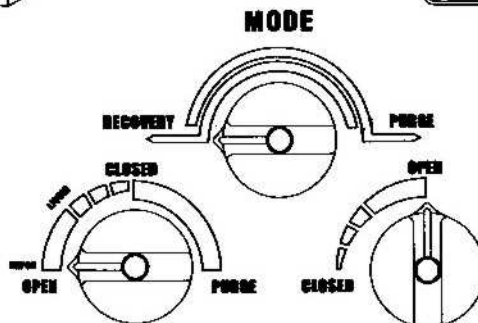
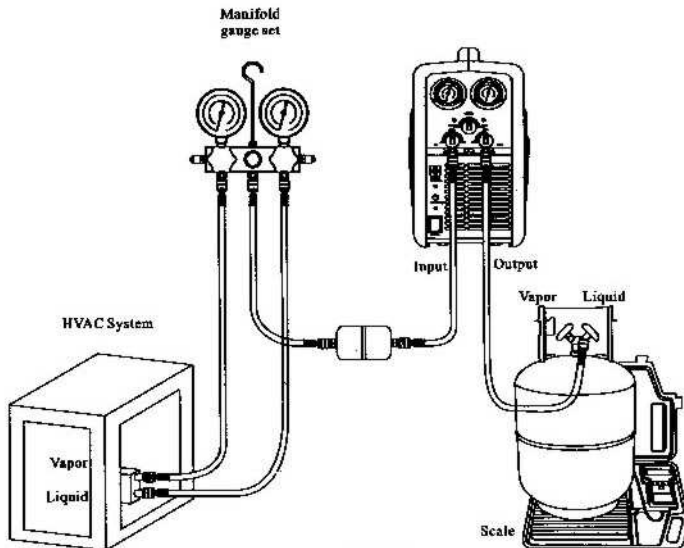

## STANDARD LIQUID/VAPOR RECOVERY PROCEDURE

7. Connect the recovery unit to a right outlet. (See the nameplate on the machine)  
Switch the power switch to the ON position, to start the compressor.
8. Slowly open the input port on the machine.
  - 1) If the compressor starts to knock, slowly throttle back the input valve until the knocking stops.
  - 2) If the input valve was throttled back, it should be fully opened once the liquid has been removed from the system (the manifold gauge set vapor port should also be opened at this time).
9. Run until desired vacuum is achieved.
  - 1) Close the manifold gauge sets vapor and liquid ports.
  - 2) Turn off the machine.
  - 3) Close the unit's input port and proceed with the SELF-PURGE PROCEDURE on the next page.

### Note:

**If the recovery machine fails to start, rotate the INPUT valve and the MODE valve to purge position. Then rotate the MODE valve back to recovery position, and open the INPUT valve.**

### Caution:

**Always purge the unit after each use. Failure to purge the remaining refrigerant from the unit could result in the acidic degradation of internal components, ultimately causing premature failure of the unit.**

## SELF-PURGING PROCEDURE

Procedure for purging remaining refrigerant from this machine.

1. Close the ports of the system being serviced that are connected to the input port of the machine.
2. Turn off the recovery machine.
3. Turn the Input valve to the PURGE position.
4. Turn the MODE valve to the PURGE position.
5. Restart the machine.
6. Run until desired vacuum is achieved.
7. Close the ports on the recovery tank and the machine.
8. Turn the machine off.
9. Return the MODE valve to the RECOVER position.
10. Disconnect and store all hoses and dry filter.

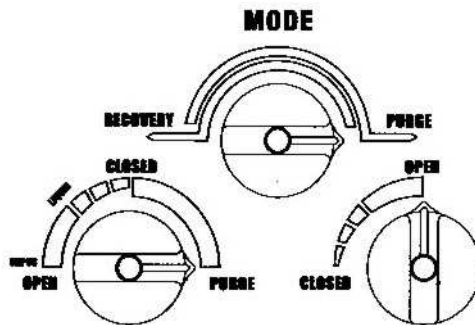

## LIQUID PUSH/PULL PROCEDURE

Push/pull procedure only works with large systems where the liquid refrigerant is no less than 6.8kg (15lbs.).

1. put MODE valve knob on RECOVER.
2. Open OUTPUT valve.
3. Open INPUT valve.
4. When the scale stops rising close all ports.
5. Switch off the machine.

### CAUTION:

When using the "Push/pull" method, a scale must be used to avoid over filling the storage tank, once the siphon is started, it can continue and overflow the storage tank even if the tank is equipped with a float level sensor. The siphon can continue even when the machine is turned off. You must manually close the valves on the tank and the unit to prevent overflowing of the recovery tank.

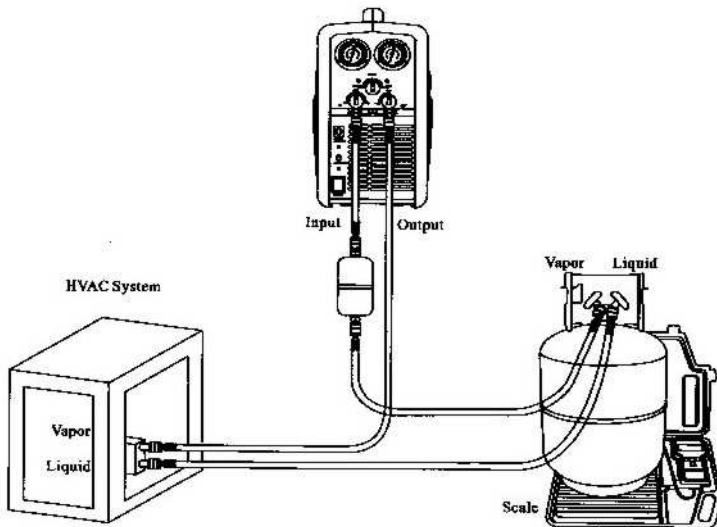



## TANK COOLING PROCEDURE (OPTIONAL)

In order for this procedure, you must have a minimum of 5 lbs. (2.3kg) of liquid refrigerant in the storage tank.

1. Connect the hoses as shown
2. Turn the MODE valve to the Recover position.
3. Open the Vapor and Liquid valve of the storage tank.
4. Power on, and start the compressor.
5. Open the INPUT valve and OUTPUT valve of the machine.
6. Throttle the OUTPUT valve of the machine so that the output pressure is 100psi greater than the input pressure, but never more than 300psi.
7. Run until tank is cold.

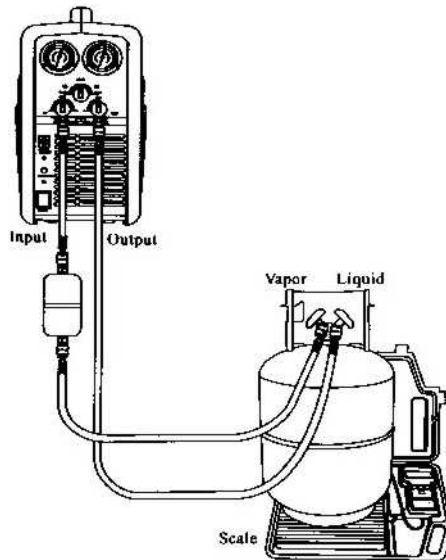

## ALTERNATIVE/COOLING PROCEDURE (OPTIONAL)

Set up your equipment as shown, it is possible to cool the storage tank during the recovery procedure if necessary.

1. Open the vapor valve of the storage tank (it is closed while recovering).
2. Close the two valves of the manifold gauge set.
3. Follow the sixth and seventh items of the tank Cooling Procedure.

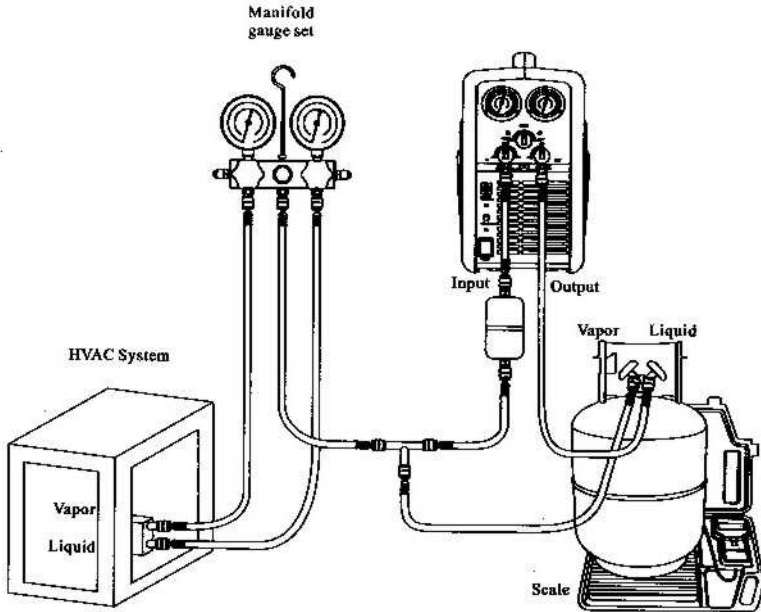

## OIL SEPARATING PROCEDURE

This procedure is only for RECO25 O.S. (Recovery & Recycling)

1. Make sure all connections are correct and tight.
2. Make sure the port of drain valve is closed.
3. Make sure the MODE valve on RECOVERY position.
4. Open the liquid port of the storage tank.
5. Open the output port of the unit and liquid port on the manifold gauge set.
6. Turn the power switch to ON. Open the input valve slowly to liquid position. Run until the recovery is achieved.
7. Turn the power switch to OFF. Open the port of oil drain valve, and drain the oil into a suitable container, and then close the oil drain port.
8. Disconnect all hoses.

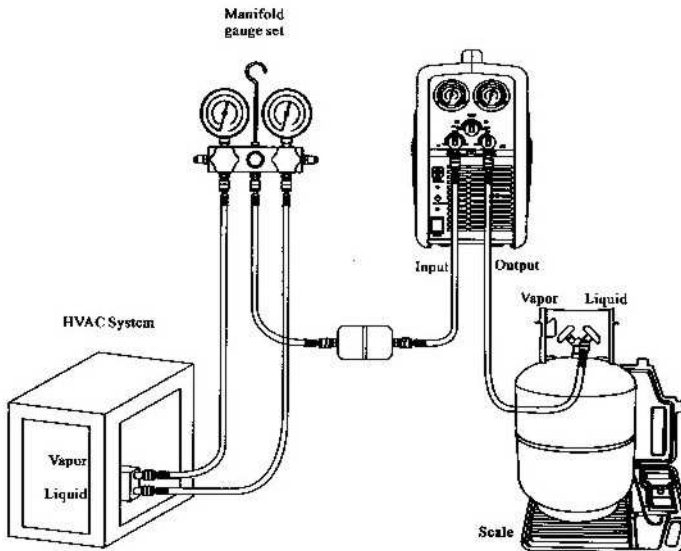

## TROUBLESHOOTING

<b>PROBLEM</b>	<b>CAUSE</b>	<b>ACTION</b>
Fan does not run when Power Switch is in ON position	Power supply cord not attached voltage is not right	Attach the power supply cord. Check power supply at job site.
	The circuit breaker has cut off	Press the button to reset
Fan runs but compressor does not start	The recovery machine is in high pressure shut off	Reduce pressure and then press the button of the High Pressure Switch.
	Output pressure is too high	Rotate INPUT valve and MODE valve to PURGE, then rotate INPUT valve back to OPEN, and MODE valve to RECOVER
	Failure in motor, or in other electrical components.	Factory service required
Compressor starts but cuts off within a few minutes	MODE valve is in PURGE position	Rotate MODE valve to RECOVER
	Output valve is not open and high pressure activates	Rotate OUTPUT valve to OPEN
	Recovery tank valve is not open	Open recovery tank valve
Recovery process too slow	Head pressure too high	Reduce tank temperature with TANK COOLING PROCEDURE
	Compressor seals are worn	Factory service required
Recovery machine does not pull out a vacuum	Connecting hoses are loose	Tighten the connecting hoses
	Leakage in unit	Factory service required

# WIRING DIAGRAM

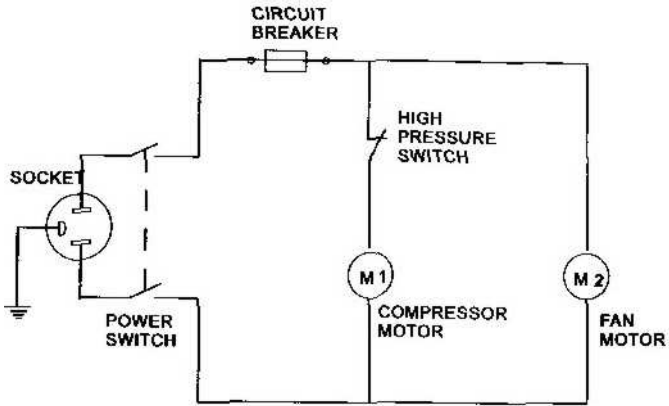

Wiring Diagram --- Standard

---

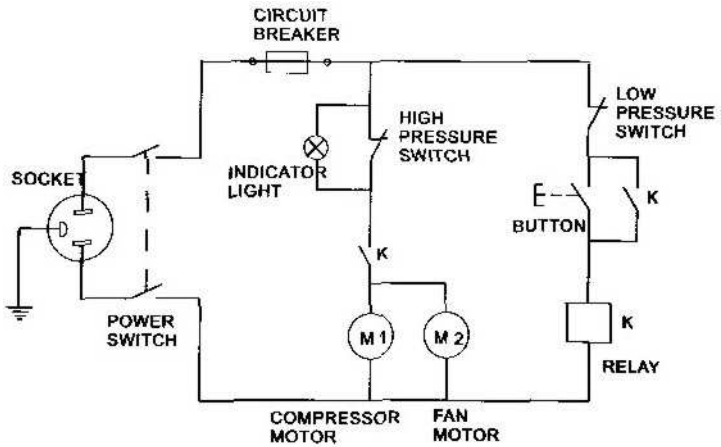

Wiring Diagram --- Low pressure shut off function

## PARTS DIAGRAM

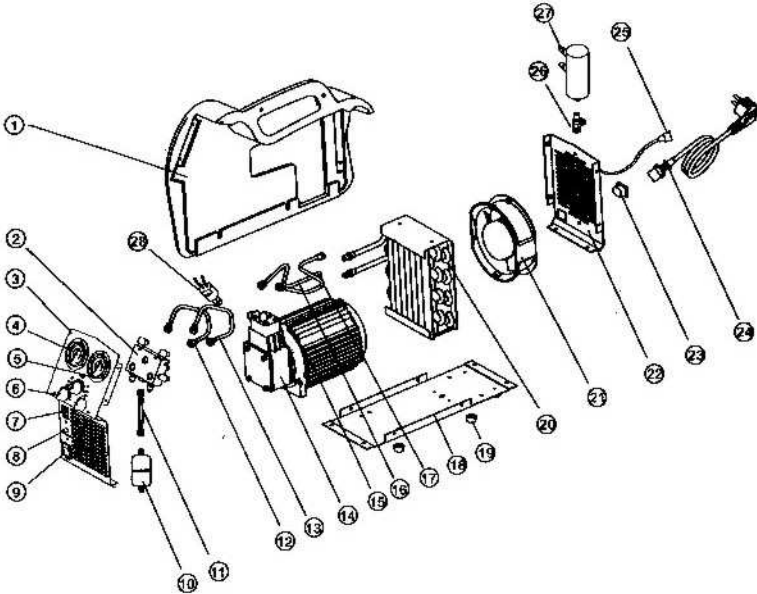

1. PLASTIC CASE	9. POWER SWITCH	17. TUB
2. CONTROL VALVE	10. DRYER/FILTER	18. BASE
3. FRONT PANEL	11. HOSE	19. RUBBER FOOT
4. INPUT GAUGE	12. TUB	20. CONDENSER
5. OUTPUT	13. TUB	21. FAN
6. KNOB	14. COMPRESSOR	22. BACK PANEL
7. CIRCUIT BREAKER	15. MOTOR	23. SOCKET
8. HP SWITCH	16. TUB	24. POWER SUPPLY CORD

---

### Optional

- 25. 80% O.F.P. SHUT OFF CORD (for RECO25 O.F.P.)
- 26. OIL DRAIN VALVE (for RECO25 O.S)
- 27. OIL SEPARATOR (for RECO25 O.S)
- 28. LP SWITCH (low pressure shut off function)