

Problems	Possible Cause / Solution
1. Recorder not working or stopped working	<ul style="list-style-type: none"> • Unplug the power connector wait 30 seconds then plug it back in. make sure the connector is plugged in securely. Be sure to observe the Green LED light turns ON. • Be sure MX9000 card is inserted all the way into it's slot securely
2. No audio	<ul style="list-style-type: none"> • Check audio cord; try re-inserting it again, adjust the volume on Recorder clockwise if needed to hear it. Check the volume on the headset(if any) Be sure MX9000 card is inserted all the way into it's slot securely
3. Audio quality is poor	<ul style="list-style-type: none"> • Verify that the "Audio In" cord is plugged in securely Make sure the source audio volume is not too loud, adjust the volume on your audio source to correct the problem..

INVO Tel User Manual
Audiolmage™ SX9100 Rev 01
Digital Audio System Player/Recorder

- Insert the blank MX9000 "True Audio Card" into the slot as shown (be sure to insert the card all the way into the blue connector)
- Connect the audio source to the "Audio Input" jack of the SX9100 using the provided 3.5mm to 3.5mm audio cord and "Y" patch connector.
- Plug one end of the RCA audio cable into the Red RCA connector, Plug the other end of the audio cable into your PBX phone system RCA connector usually labeled as "MOH". If you have regular Non-PBX telephones, plug the other end into the Music-On-Hold adapter "Audio In" RCA connector instead.
- Adjust the "Volume" up by rotating the control clock wise as shown.
- Plug the included AC adapter. (110V AC to 9V AC)

Warranty

This product is warranted against defects for a period of Three (3) years from the date of original invoice. We will repair/replace the product with no charge for parts or labor within this time. To obtain warranty service the product needs to be returned freight prepaid by the customer with a copy of original invoice. This warranty does not apply if in the sole opinion of Innovative Telecommunication Technology, the product has been tampered with or damaged by lightning or any other acts of nature, misuse, neglect or unauthorized service.

EXCEPT AS SPECIFICALLY PROVIDED IN THIS AGREEMENT, THERE ARE NO OTHER WARRANTIES, EXPRESSED OR OTHERWISE, INCLUDING, BUT NOT LIMITED TO ANY IMPLIED WARRANTIES OR MERCHANTABILITY OR FITNESS FOR A SPECIAL PURPOSE. IN NO EVENT SHALL INNOVATIVE TELECOMMUNICATION TECHNOLOGY (INVOTEL) BE LIABLE FOR LOSS OF PROFITS OR BENEFITS, INDIRECT, SPECIAL, CONSEQUENTIAL OR OTHERWISE ARISING FROM ANY BREACH OF THIS WARRANTY OR OTHERWISE.

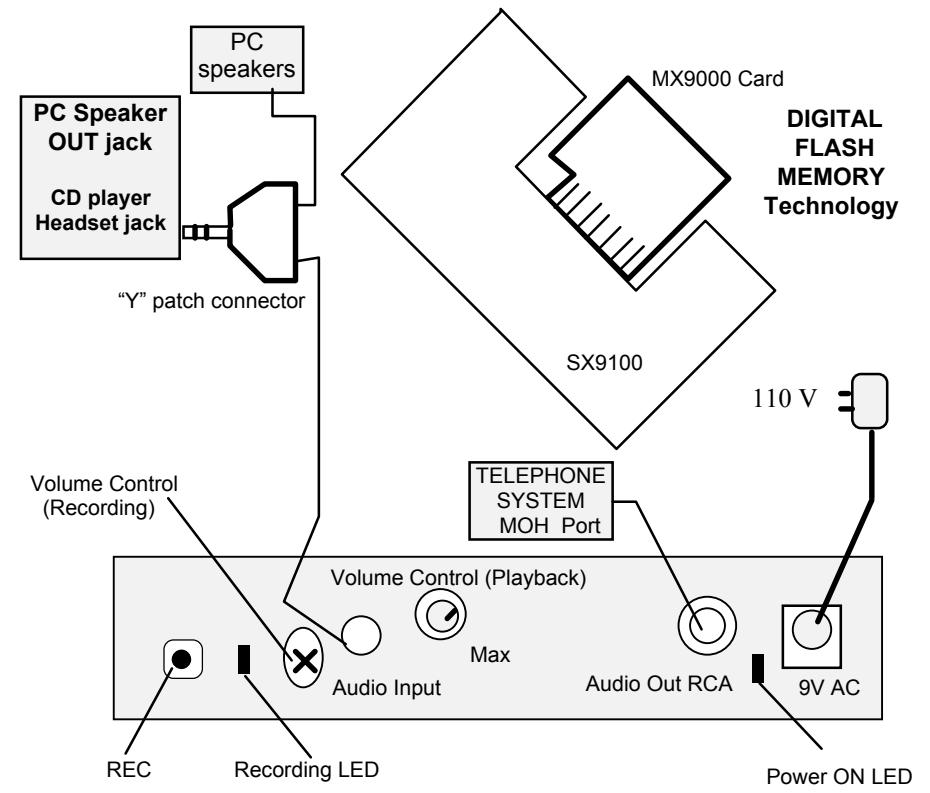

Package Content

SX9100 Digital Player/Recorder unit
Power Adapter 110v AC to 9V AC 100 ma
Audio cord 3.5mm to 3.5mm 12 feet long
“Y” patch connector (3.5mm plug to 2 x 3.5mmjacks) 1inch
RCA to RCA audio cord 6 feet long
User’s Manual
MX9000 True Audio Card (optional)

Playback

Audio playback starts automatically as soon as the power is connected, the Green LED light turns On to indicate the device is ON and is playing.

Adjusting Output Level

Use the Volume control to adjust the output level. If the Music On Hold volume is too low turn the Volume control clockwise; If the Music On Hold sounds too loud turn the Volume control counter clockwise to desired level.

Recording

Please NOTE: Recording will write over the existing audio in the MX9000 card, be sure to use a **Blank MX9000 card** or have the audio source file ready for re-recording if needed.

Before you start - adjust the volume on your audio source (PC, CD player, etc.) to about 60 to 70% level up.

- Press REC, play back stops Green LED turns OFF.
- Start your music/audio & press the REC button on the SX9100, the RED LED light turns ON and the recording starts.

You can monitor the recording via the speakers/headset of your source. You may press REC any time to STOP the recording; the playback automatically resumes. To re-record do the above steps.

To prevent accidental recording remove the 3.5 mm audio cord when done. Pressing REC button now stops/re-starts the playback and will not record.

Audio Quality If the audio quality is not acceptable the PC or other audio source volume level may be too low or too high, when the volume of the audio source is too high, the recordings may have some distortion specially

during spoken words, when the recordings are too soft the volume on the audio source is too low. Adjust the audio level on your PC or other audio source accordingly, re-record if needed.

Adjusting Recording Volume

The SX9100 is factory calibrated for recording at a mid level audio from a PC or other sound source, therefore the recording adjustment on the SX9100 does not need to be changed. If for some unforeseen reason your audio source is too low (even after you crank up the volume on it), you can rotate this adjustment pot with a Philips screw driver clock wise to increase the recording volume. (or counter clock wise to reduce the recording volume)

MX9000 Card “True Audio Card”

The MX9000 card is a Flash card that holds the recordings. Make sure the power is OFF prior to inserting this card into the slot. If you need to re-insert the MX9000 card or record another MX9000 card be sure to remove the power by un plugging the 9V from the player, then insert the new MX9000 card (Multi MX9000 gang recorder is available)

Unlike other Flash based cards that compress the audio, voice and audio signals are recorded directly into solid state memory in the MX9000 card in their natural, uncompressed form, providing superior quality voice and music reproduction. MX9000 card has 100 -year retention time at zero power and can be re-recorded 100,000 times.

Specifications:

File Formats: supports file formats such as Windows .wav, MP3, WMA,
Frequency response 20Hz to 20 KHz.

Sampling rate: supports both 8-bit and 16-bit uncompressed PCM sampled at 8, 11, 12, 16, 22, 24, 32, 44 & 48 KHz

Distortion: less than 0.1% THD

Audio Quality: supports better than CD Quality at 188 KB/s

Special effects: can record from Media player turning ON SRS & WOW Effects

Memory Capacity (MX9000 card) 1 to 16 minutes

Maximum audio storage 8 minutes 40 seconds (high quality mode)

Size: 4” x 2” x 0.9” (L x W x H)

Size MX9000 1.5” x 1.5” x 0.37” (L x W x H)

Color: Black

Weight: 0.2 pounds (0.50 pounds with power supply)