

Liebert.PEX Condenser

User Manual

Version	V1.6
Revision date	October 27, 2008
BOM	31011645

Emerson Network Power provides customers with technical support. Users may contact the nearest Emerson local sales office or service center.

Copyright © 2008 by Emerson Network Power Co., Ltd.

All rights reserved. The contents in this document are subject to change without notice.

Emerson Network Power Co., Ltd.

Address: No.1 Kefa Rd., Science & Industry Park, Nanshan District 518057, Shenzhen China

Homepage: www.emersonnetworkpower.com.cn

E-mail: support@emersonnetwork.com.cn

Contents

Chapter 1 Overview	1
1.1 Classification And Model.....	1
1.2 Model Description	1
1.3 Main Component.....	1
1.4 Technical Parameter.....	2
1.4.1 Mechanical Parameter.....	2
1.4.2 Mounting base dimension.....	3
1.4.3 Parameters Of Operating Environment	4
1.4.4 Parameters Of Storage Environment.....	4
Chapter 2 Installation	5
2.1 Moving, Unpacking And Inspection.....	5
2.2 Installation Notes	6
2.3 Space Requirements	6
2.4 Installation Procedures	7
Chapter 3 Application Of Fan Speed Controller	9
3.1 Wiring Terminals.....	9
3.2 HMI	10
3.3 Operation Description Of HMI.....	11
3.3.1 Initial Interface	11
3.3.2 Main Menu Interface	11
Chapter 4 Maintenance And Troubleshooting	14
4.1 Maintenance	14
4.2 Troubleshooting	15
Appendix 1 Circuit Diagram.....	16

Chapter 1 Overview

This chapter introduces the classification, model, model description, main components and technical parameters of Liebert.PEX condenser (condenser for short).

1.1 Classification And Model

The condenser is classified into two types: single system and double system. The single system has a set of discharge / liquid pipe to match the single refrigeration system of indoor unit. The double system has two sets of discharge / liquid pipes to match the two separate refrigeration systems of indoor unit.

The condenser is available in 15 models. The classification and models are listed in Table 1-1.

Table 1-1 Condenser models

Classification	Model
Single system	LSF24, LSF32, LSF38, LSF42, LSF52, LSF62, LSF70, LSF76, LSF85
Double system	LDF42, LDF52, LDF62, LDF70, LDF76, LDF85

1.2 Model Description

Taking LSF62 as an example, the model description of the condenser is shown in Figure 1-1.

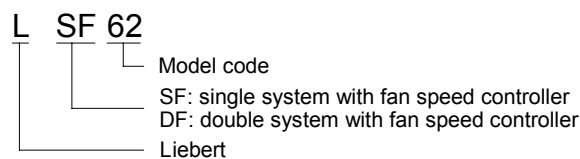

Figure 1-1 Model description

1.3 Main Component

The main components of the condenser include heat exchanger, fan, fan speed controller and pressure sensor. The heat exchanger is inside the condenser, and the appearance and position of other components are shown in Figure 1-2 and Figure 1-3.

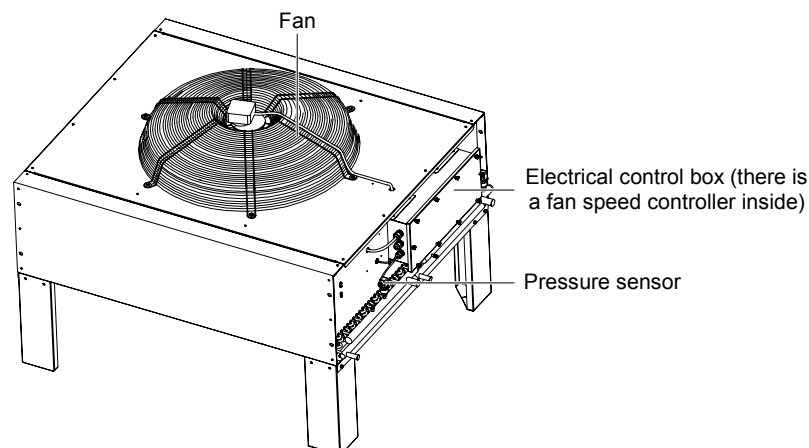

Figure 1-2 PEX condenser (single fan)

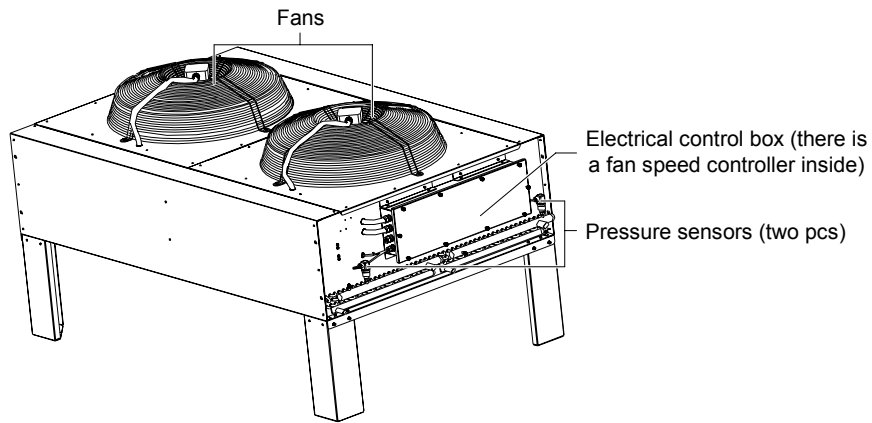

Figure 1-3 PEX condenser (double fans)

1.4 Technical Parameter

1.4.1 Mechanical Parameter

The condenser structure is shown in Figure 1-4. The mechanical parameters of each model are listed in Table 1-2.

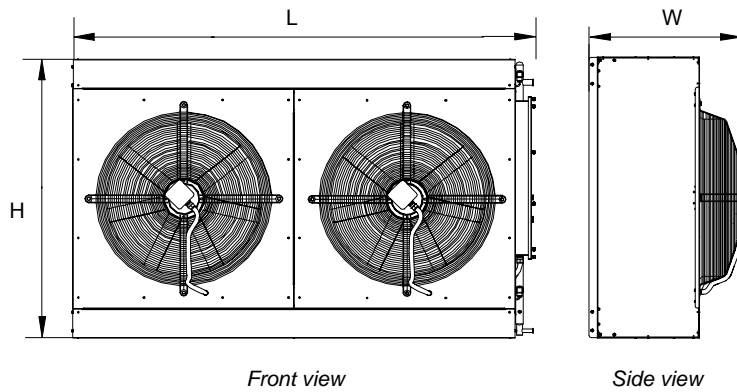

Figure 1-4 Structure (double fan)

Table 1-2 Mechanical dimensions

Model	Weight (kg)	Fan diameter (mm)	Fan number	Dimension (mm)		
				L	H	W
LSF24	105	710	1	1374	990	689
LSF32	110	710	1	1374	990	689
LSF38	120	800	1	1374	990	695
LSF42	130	800	1	1574	1273	695
LSF52	140	800	1	1574	1273	695
LSF62	150	710	2	1874	1273	689
LSF70	150	710	2	1874	1273	689
LSF76	220	800	2	2374	1273	695
LSF85	230	800	2	2374	1273	695
LDF42	130	800	1	1574	1273	695
LDF52	140	800	1	1574	1273	695
LDF62	160	710	2	2074	1273	689
LDF70	160	710	2	2074	1273	689
LDF76	220	800	2	2374	1273	695
LDF85	230	800	2	2374	1273	695

1.4.2 Mounting base dimension

Mounting base dimension for horizontal installation

The mounting base for horizontal installation is shown in Figure 1-5, and the detailed mounting base dimensions of each model are listed in Table 1-3.

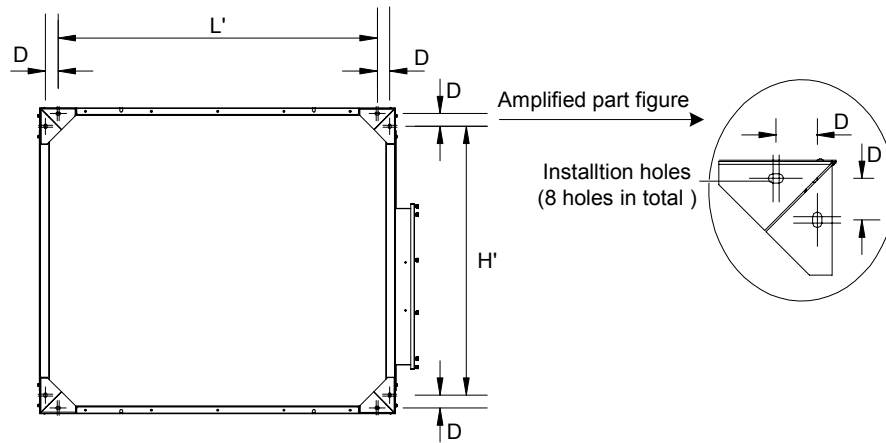

Figure 1-5 Mounting base figure for horizontal installation

Table 1-3 Mounting bases dimensions for horizontal installation (unit: mm)

Model	Dimension (L' × H' × D)	Model	Dimension (L' × H' × D)
LSF24	1126 × 837 × 53	LSF85	2126 × 1120 × 53
LSF32	1126 × 837 × 53	LDF42	1326 × 1120 × 53
LSF38	1126 × 837 × 53	LDF52	1326 × 1120 × 53
LSF42	1326 × 1120 × 53	LDF62	1826 × 1120 × 53
LSF52	1326 × 1120 × 53	LDF70	1826 × 1120 × 53
LSF62	1626 × 1120 × 53	LDF76	2126 × 1120 × 53
LSF70	1626 × 1120 × 53	LDF85	2126 × 1120 × 53
LSF76	2126 × 1120 × 53		

Note

The installation holes are long and flat holes. It is recommended to use M10 × 20 bolts to fix the mounting base.

Mounting base dimension for vertical installation

The mounting base dimensions for vertical installation is shown in Figure 1-6.

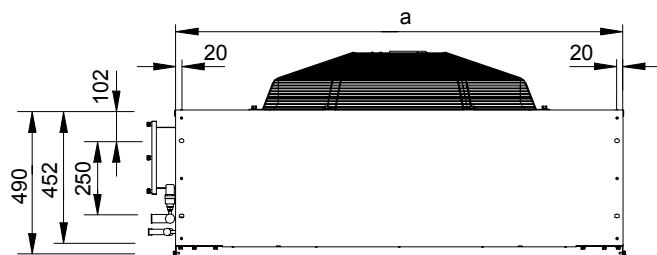

Figure 1-6 Mounting base figure for vertical installation (top view)

Table 1-4 Mounting bases dimensions for vertical installation (unit: mm)

Model	a dimension
LSF24, LSF32, LSF38	1280
LSF42, LDF42, LSF52, LDF52	1480
LSF62, LSF70	1780
LDF62, LDF70	1980
LSF76, LDF76, LSF85, LDF85	2280

 **Note**

1. The installation holes are long and flat holes. It is recommended to use M10 × 20 bolts to fix the mounting base.
2. The over condenser must be installed on a rack during vertical installation and the cushion pads should be used between the condenser and the rack for damping. It is prohibited to stack two condensers through screw connection.

1.4.3 Parameters Of Operating Environment

The operation environment parameters of the condenser meet GB/T4798.3-1990 and GB/T19413-2003. See Table 1-5 for details.

Table 1-5 Parameters of operation environment

Item	Requirement
Installation position	The standard equivalent distance between the indoor unit and condenser is 30m. The vertical difference* ΔH : $-5m \leq \Delta H \leq 20m$. The installation mode: horizontal or vertical mode
Environmental temperature	Outdoor temperature: $-20^{\circ}\text{C} \sim +45^{\circ}\text{C}$. Low temperature accessories are required if the temperature is $-35^{\circ}\text{C} \sim -20^{\circ}\text{C}$
Environmental humidity	Outdoor: 5%RH ~ 95%RH
Operation power	380V \pm 10%, 50Hz
Altitude	$\leq 1000\text{m}$. Derating is required if the altitude exceeds 1000m
Protection level	Electrical control box: IP55; unit: IP20
Note*: The value is positive if the condenser is installed higher than the indoor unit; and negative if the indoor unit is installed higher than the condenser	

 **Note**

When the equivalent distance between the indoor unit and condenser exceeds 30m, refer to 5.1 Refrigerant Tubing System in Liebert.PEX Series Air Conditioner Technical Manual for the detailed requirement for the line equivalent length.

1.4.4 Parameters Of Storage Environment

The storage environment parameters of the condenser meet GB/T4798.1-2005 and GB/T19413-2003. See Table 1-6 for details.

Table 1-6 Parameters of storage environment

Item	Requirement
Storage environment	Clean indoor environment with good ventilation and no dust
Environmental temperature	$-40^{\circ}\text{C} \sim +70^{\circ}\text{C}$
Environmental humidity	5%RH ~ 85%RH
Storage time	The total storage time should not exceed 6 months. Otherwise, the performance needs to be re-calibrated

Chapter 2 Installation

This chapter introduces the moving, unpacking, inspection, installation notes, space requirements and installation procedures.

2.1 Moving, Unpacking And Inspection

Moving

It is recommended to use mechanical transport equipment such as forklift or crane when unloading and transferring the condenser closest to the installation site.

When a forklift is used, insert the tines of the forklift as shown in Figure 2-1 (taking single fan condenser for example).

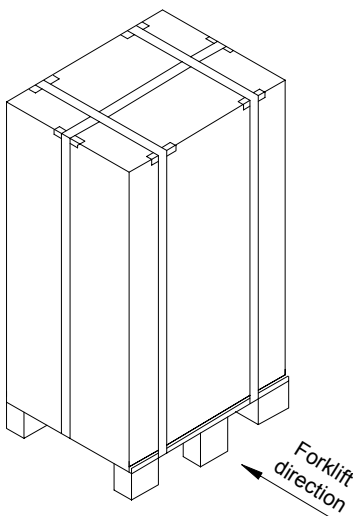

Figure 2-1 Forklift direction

When a crane is used, refer to Figure 2-2 to lift the package (taking the double fan condenser for example).

Note

When lifting the package, fix the cable by leading it through the slot at the bottom of the pallet. Otherwise, the cable may slide during the lifting process, and the package may fall to the ground, damaging the pipes within and resulting in system leakage.

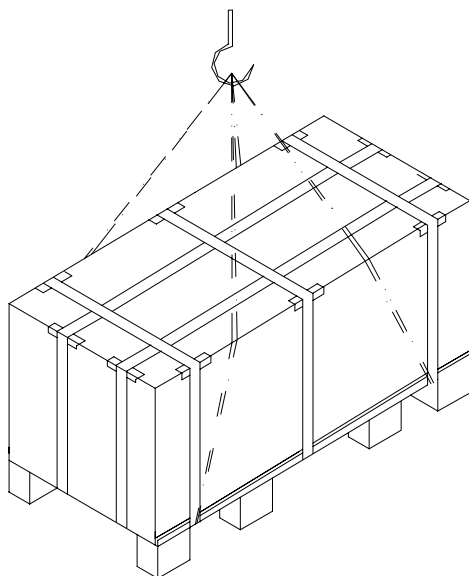

Figure 2-2 Crane lifting

Unpacking

Remove the paper package and foam of the condenser but reserve the protection cardboard of fins. The protection cardboard of fins and the cushion pad of U tube on the end of the condenser should be removed after the condenser is in its installation position.

Note

1. If the condenser is to be placed horizontally, you should complete the installation of legs while the condenser is located vertically.
2. When moving the condenser by hand, to avoid distortion and system leakage, do not touch the copper pipes.

Inspection

After receiving the product, you should check the accessories against the packing list. If any parts are found missing or damaged, please report to the carrier immediately. If any covert damage is found, please report to the carrier and the distributor too.

2.2 Installation Notes

The installation notes of the condenser are as follows:

1. To ensure the heat dissipation capacity, install the condenser in the place with smooth air flow. Do not install it where the coil of the condenser may be obstructed by dust and snow. Ensure that there is no steam or waste heat around.
2. If possible, the horizontal installation is recommended to reduce the noise.
3. The condenser should be installed as far away as possible from residential areas ($\geq 15\text{m}$).
4. Be careful not to damage the waterproof layer and observe the local rules and regulations when the condenser is installed on the roof of building.
5. Position the condenser higher than the indoor unit to ensure normal oil return.
6. Follow the installation arrows on the condenser for the installation direction.

2.3 Space Requirements

Note

1. A 4000mm clearance is required around the condenser air outlet.
2. The 600mm service spaces are required on the four sides of the condenser.

The condenser needs sufficient installation and service space around the installation place. The detailed space requirements are shown in Figure 2-3 and Figure 2-4.

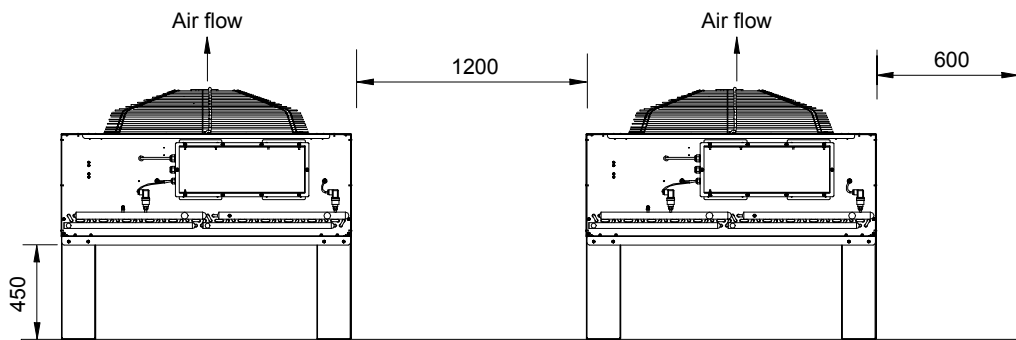

Figure 2-3 Horizontal installation space requirement (unit: mm)

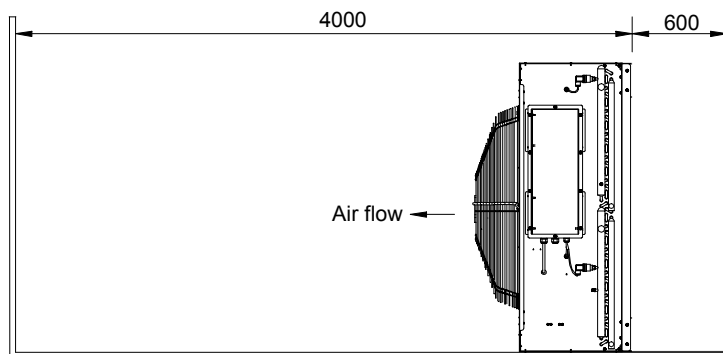

Figure 2-4 Vertical installation space requirement (unit: mm)

2.4 Installation Procedures

Note

To ensure the safety, before welding the pipeline and patching welding, all nitrogen of air condition system must be discharged to release the system pressure.

Installing pipelines

Note

1. The copper pipes should be heat preserved. When the copper pipes pass through the wall or other obstacles, take isolation measure such as using the shock pad to avoid direct contact with the wall. Prevent the dust, water vapor and solid particles from entering the copper pipes.
2. To ensure the quality of welding, the silver-based solder with good quality is required to weld the elbow- pipe. The nitrogen protection should be done while welding.

1. Identifying the pipe sizes

Refer to 2.6 *Installing Unit Pipes* in *Liebert.PEX Series Air Conditioner User Manual* for pipe sizes.

2. Identifying the condenser installation height

Refer to 2.6 *Installing Unit Pipes* in *Liebert.PEX Series Air Conditioner User Manual* for the installation height.

3. Installing pipes

Install the pipes according to the factual conditions and industry standard.

Connecting external power (external power supply of the condenser)

1. Identifying the cable specifications

Select the power supply cables and the start/stop signal cables of the condenser according to the fan rated operation current (see Table 2-1) and the site conditions, such as the distance between indoor unit and condenser.

Table 2-1 Operation current of fan under 380V voltage

Condenser Model	Rated current (A)
LSF24	1.65
LSF32	1.05
LSF38, LSF42, LSF52, LDF42, LDF52	2.4
LSF62, LSF70, LDF62, LDF70	3.3
LSF76, LSF85, LDF76, LDF85	4.8

Note

1. The 20AWG (0.52mm²) start / stop signal cable of the condenser is recommended.
2. The protected tube or shielded line is required for the outdoor part of the connection cable between the indoor unit and the condenser. The ground cable should be connected to the ground nearby, and the length cannot exceed 3m.
3. The cables cannot contact with hot objects, such as the copper tube and water pipe without insulation, to avoid damaging the insulation layers.
4. The cables should be connected in accordance with the local regulations.

2. Connecting cables

See Figure 2-5, Figure 2-6 and *Appendix 1 Circuit Diagram* for the connections of external power cables.

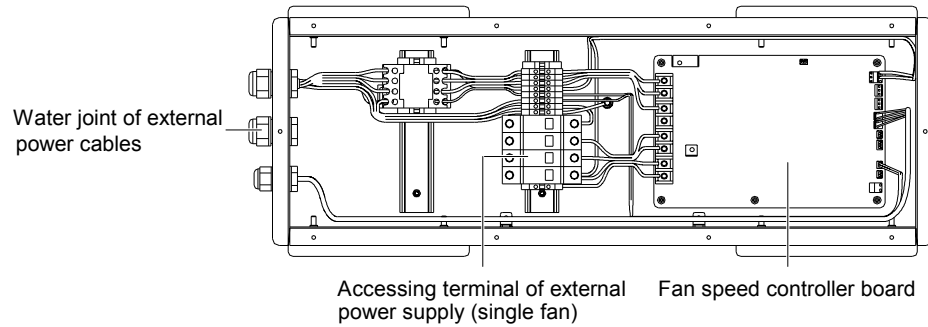

Figure 2-5 Connection figure of single fan external power cables (taking LDF42 for example)

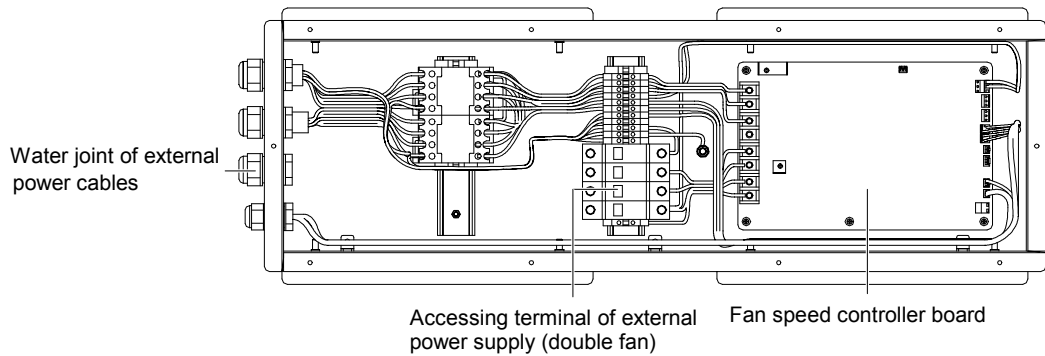

Figure 2-6 Connection figure of double fan external power cables (taking LDF62 for example)



Note

1. The external power lines and compressor signal lines enter the electrical controlling box through the water joint of external power cables whose inside diameter is $\Phi 10\text{mm}$.
2. After connecting the external power lines, the waterproof sealant treatment is required to ensure the good waterproof performance of electrical controlling box.
3. The phase order of three-phase AC input (L1, L2, L3) must be correct. Otherwise, the fan speed controller will generate the phase loss alarm, and there will be no AC output.
4. For the condensers with double system (such as LDF42, LDF52, LDF62, LDF70, LDF76 and LDF85), the four condenser start / stop signal lines should be paralleled at the terminal block of indoor unit before connection; For the condensers with single system, the two condenser start / stop signal lines can be connected directly.

Charging refrigerant and adding cooling oil

Refer to 2.6 *Installing Unit Pipes* in *Liebert.PEX Series Air Conditioner User Manual* for charging refrigerant and adding cooling oil.

Chapter 3 Application Of Fan Speed Controller

This chapter introduces the use of the fan speed controller, which includes the definitions of wiring terminals, introduction of Human-Machine Interface (HMI) and operation of HMI. This chapter is mainly for the factory maintenance personnel. It is recommended that users should not operate the fan speed controller unless necessary.

Note

The fan number configured must be the same as the factual fan number, or else the alarm will be generated. Refer to *Configuration data main menu interface in 3.3.2 Main Menu Interface* for detailed setting.

3.1 Wiring Terminals

The wiring terminals are located on the fan speed controller board (see Figure 2-5 and Figure 2-6). Their distribution is shown in Figure 3-1 and the definitions are listed in Table 3-1. Refer to *Appendix 1 Circuit Diagram* for detailed connections.

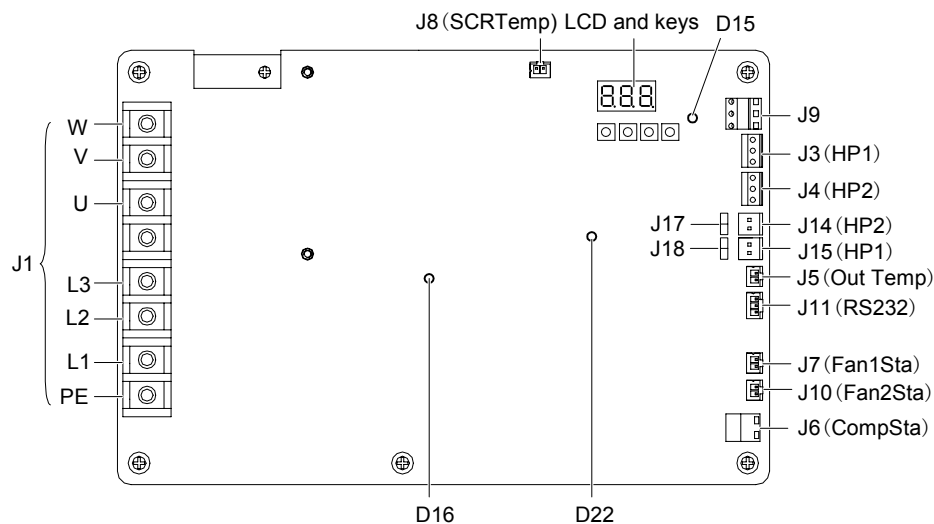

Figure 3-1 Layout of wiring terminals

Table 3-1 Definitions of wiring terminals

Silk print	Definition	Definition of pins
J1	AC I/O terminal	PE: protection earth L1, L2, L3: three-phase AC input U, V, W: three-phase AC output, which connects with the power supply terminals The middle terminal pin without logo is reserved
J9	Passive dry contactor relay output (for the power switch of fan power supply contactor)	Pin 1: normally closed terminal of relay, which is reserved Pin 2: common terminal of relay, which is used for AC input Pin 3: normally open terminal of relay, which is used for AC output
J3 (HP1)	Input terminal of voltage pressure sensor 1 (spare)	Pin 1: positive terminal of 5V power Pin 2: input terminal of 0.5V ~ 4.5V pressure voltage signal Pin 3: negative terminal of 5V power
J4 (HP2)	Input terminal of voltage pressure sensor 2 (spare)	
J15 (HP1)	Input terminal of current pressure sensor 1	Pin 1: positive terminal of 12V power Pin 2: input terminal of 4mA ~ 20mA pressure current signal
J14 (HP2)	Input terminal of current pressure sensor 2	
J17, J18	Shorting jumpers of current pressure sensor	Current pressure sensor: the short circuit ring must be installed on the shorting jumpers Voltage pressure sensor: the open state of short jumpers must be kept

Silk print	Definition	Definition of pins
J5 (Out Temp)	Input terminal of environment temperature sensor (spare)	Pin 1: input terminal of temperature signal Pin 2: signal ground
J11 (RS232)	Serial communication interface (used for maintenance)	Pin 1: communication ground Pin 2: reception terminal of communication Pin 3: transmission terminal of communication
J7 (Fan1Sta)	Detecting terminal of fan 1 over temperature state	Pin 1: output terminal of 19V AC signal Pin 2: return terminal of 19V AC signal
J10 (Fan2Sta)	Detecting terminal of fan 2 over temperature state	
J6 (CompSta)	Detecting terminal of compressor state	
Note : J8 (SCRTemp) in Figure 3-1 is the interface of fan speed controller board, and not to be used by users		

3.2 HMI

The fan speed controller can realize the HMI function through indicators, RS232 serial communication port, keys and LCD.

Indicators

There are three indicators (see Figure 3-1) on the fan speed controller board. See Table 3-2 for the functions of indicators.

Table 3-2 Functions of indicators

Silk print	Definition	Color	State	Function
D16	Power indicator	Green	On	The CPU circuit of fan speed controller board is supplied with 5V power
			Off	There is a faulty on fan speed controller board
D22	Run indicator	Green	On or off	There is a faulty on fan speed controller board
			Blinking at 1Hz (slowly)	The system is running normally without alarm
			Blinking at 5Hz (quickly)	There is an alarm or the compressor is shut down
D15	Power switch controlling indicator of AC contactor	Red	On	The control switch which supplies the AC contactor with the driving power is open
			Off	The control switch which supplies the AC contactor with the driving power is closed

RS232 serial communication port

RS232 serial communication port provides a port to interface the computer using factory-defined protocol. It is used in factory commissioning and maintenance.

Keys and LCD

The keys and LCD, which can realize the functions in Table 3-3, provide the HMIs for maintenance personnel. Refer to 3.3 Operation Description Of HMI for the detailed operations of keys and LCD HMI.

Table 3-3 Function descriptions of keys and LCD

NO.	Function	Description
1	Inquire the acquisition data in real time	The inquired acquisition data includes condensing pressure, environment temperature, SCR temperature, output percentage
2	Inquire the current alarm data in real time	The inquired current alarm data includes phase loss alarm, SCR over temperature, fan 1 over temperature, fan 2 over temperature, pressure sensor failure, EEPROM read fault alarm, SCR temperature sensor failure and abnormal frequency
3	Inquire the historical alarm data in real time	The present 100 historical alarms saved can be inquired
4	Change the configured parameters in real time	The changeable configured parameters include running pressure, pressure controlling range, minimum voltage, maximum voltage, fan number, pressure sensor type; or resume the default values

The keys and LCD are on the upper right corner of the fan speed controller, as shown in Figure 3-1. Their appearance is shown in Figure 3-2.

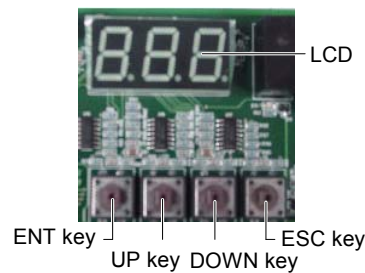

Figure 3-2 Keys and LCD

3.3 Operation Description Of HMI

3.3.1 Initial Interface

The LCD will display alternately 'F01' and the bigger one of condensing pressure 1 and condensing pressure 2 when the fan speed controller is powered on initially. The 'F01' is the maximum pressure logo. However, the pressure value will be displayed as '88.8' on the LCD upon the following occasions:

1. The pressure sensor is not installed,
2. The short jumper cap of current pressure sensor is not installed.
3. The pressure sensor is disabled.

The show order is shown in the following figure (the '16.1' is only an example, and the actual value is determined by the sampling result).



3.3.2 Main Menu Interface

Press the ESC key on the initial interface, the main menu interface will appear on the LCD. The main menu interface includes the analog main menu interface, current alarm main interface, historical alarm main menu interface and configuration main menu interface. Press the UP key and DOWN key to select the different main menu interface, and press the ENT key to enter the submenu of the current main menu on the main interface. The switching operation processes and orders of the main menus are shown in the following figure.

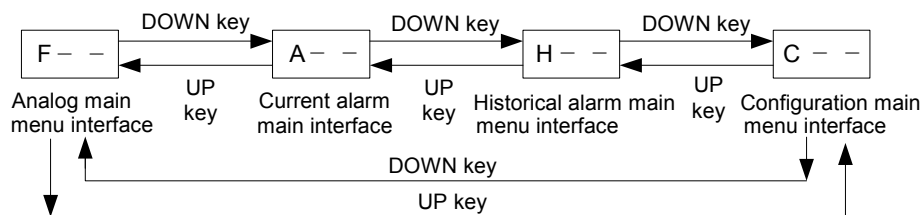

Analog main menu interface

Press the ENT key to enter the analog submenu interface when the current main interface shows 'F--' (the symbol of analog main menu). The switching operation processes and orders of the analog submenu are shown in the following figure.

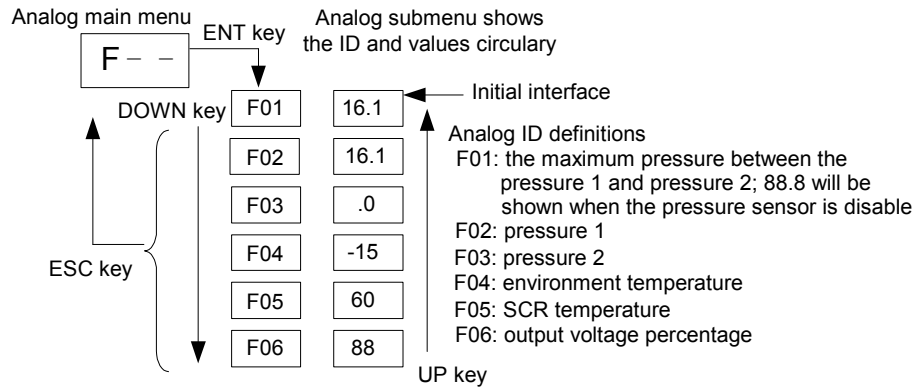

Current alarm main interface

Press the ENT key to enter the current alarm submenu interface when the current main interface shows 'A--' (the symbol of current alarm main menu). The switching operation processes and orders of the current alarm submenu are shown in the following figure.

See Table 4-1 for generating conditions and troubleshooting.

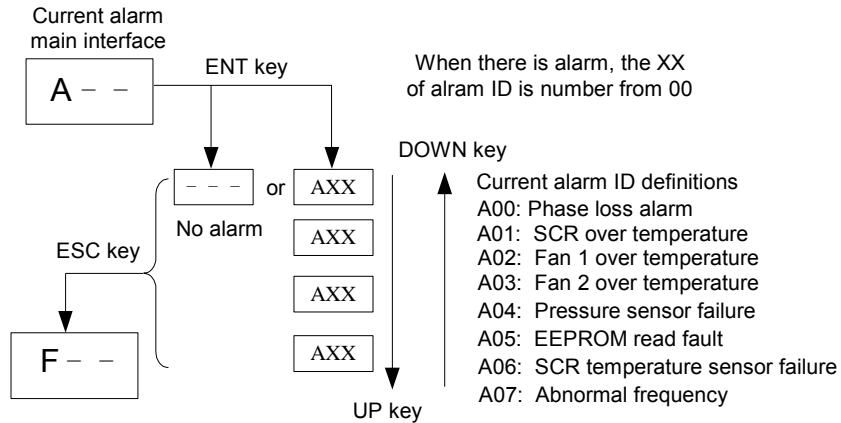

Historical alarm main menu interface

Press the ENT key to enter the historical alarm submenu interface when the current main interface shows 'H--' (the symbol of historical main menu). The switching operation processes and orders of the historical main menu are shown in the following figure.

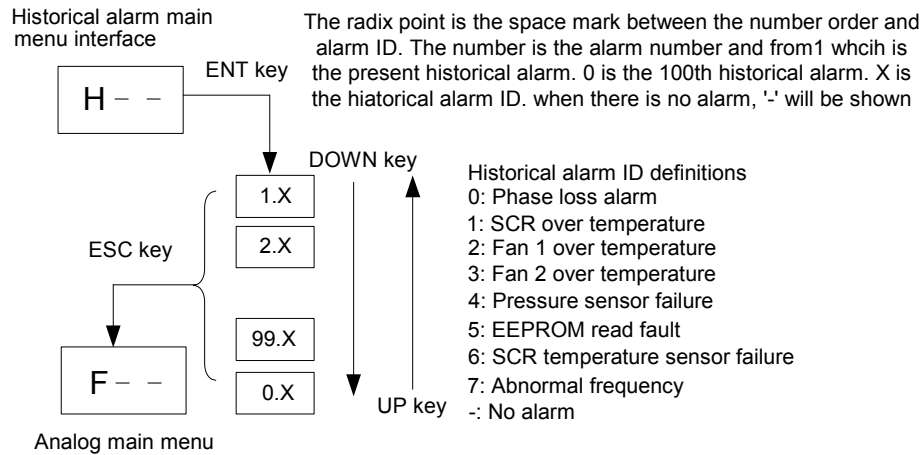

Configuration data main menu interface

Note

The configuration data main menu interface is designed only for maintenance personnel to set parameters, others are prohibited to operate it.

Press the ENT key to enter the configuration data submenu interface when the current main interface shows 'C--' (the symbol of configuration data main menu). The switching operation processes and orders of the configuration data main menu are shown in the following figure.

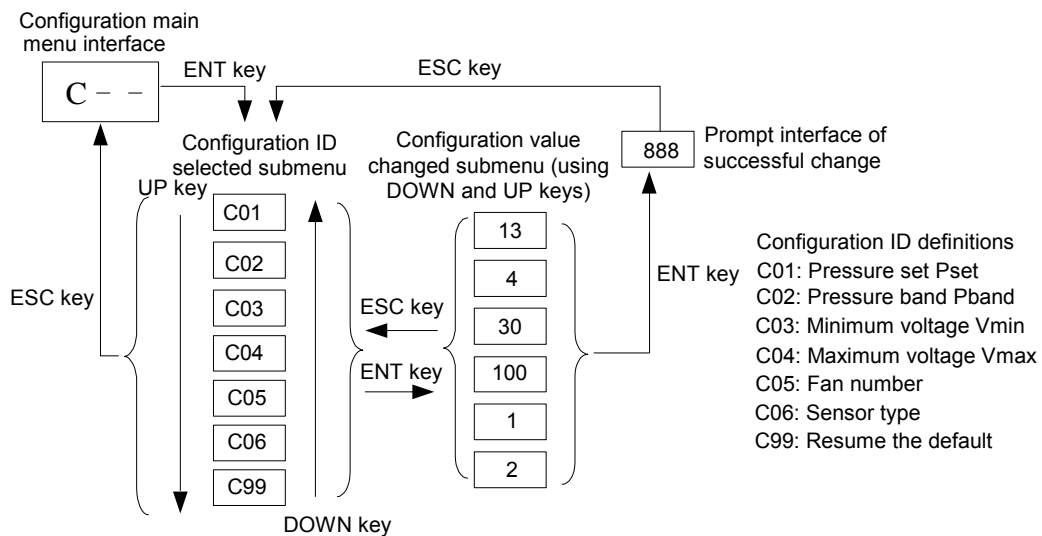

Chapter 4 Maintenance And Troubleshooting

This chapter introduces the maintenance and troubleshooting of the condenser. Users should check the condenser regularly and solve the problems in time.

Note

1. The maintenance of the condenser must be done by technicians.
2. Except for the commissioning items that must be carried out with power on, during maintenance, the power of the indoor unit and the air switch of the condenser must be cut off.

4.1 Maintenance

Refrigeration system

1. Check that the refrigeration pipes are firmly fixed. The refrigeration pipes shall not shake with the vibration of wall, earth or equipment frame. Otherwise reinforce the refrigeration pipes with fastening objects.
2. Check that there is no oil on the accessories of all refrigeration pipes, and make sure that the pipes do not leak.

Heat exchanger

1. Clean the fin of heat exchanger regularly.
2. Clean the fin of heat exchanger with compressed air or fin detergent (weakly alkaline) if the condenser air flow is blocked. The direction of inverse air flow is good when the compressed air is used.
3. Check for damaged fins and maintain them in time.
4. Avoid snow accumulation around the condenser in winter.

Fan

Check whether the fan runs normally, check it for problems such as abnormal noise, vibration and bearing failure.

Fan speed controller

Check whether the fan speed controller board operates normally. If not, replace it as illustrated in the following paragraph.

Note

Note that the position of bolt installation holes on the fan speed controller could be different on the actual product.

The fan speed controller is inside the electrical control box (see Figure 1-2 and Figure 1-3). Remove the cover plate of electrical control box before removing the fan speed controller board. Except for the seven bolts in Figure 4-1, other bolts are prohibited to be removed. The bolt 1 and bolt 2, which are used to fix the heat sink on the fan speed controller board, must be fastened firstly. The heat sink must cling to the floor of the electrical control box. After installing the heat sink, use the other five bolts to fix the fan speed controller board.

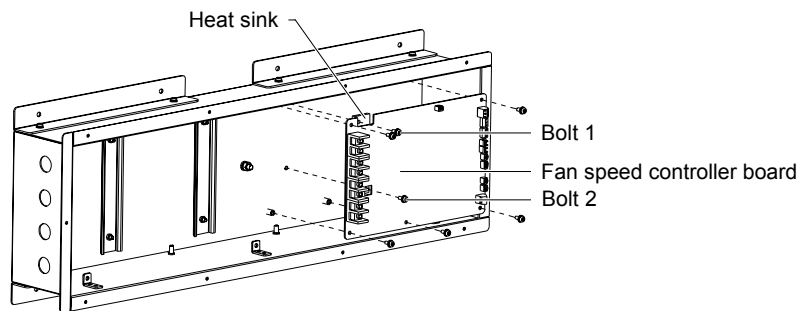

Figure 4-1 Removing the fan speed controller board

4.2 Troubleshooting

See Table 4-1 for alarm troubleshooting.

Table 4-1 Table of alarm troubleshooting

Alarm number ID	Alarm name	Cause	Troubleshooting
A00	Phase loss alarm	1. One phase or two phase of three-phase voltage is lost	1. Measure that the three-phase voltage is correct
		2. The input connection is reversed	2. Check the input order of wire
		3. The fan speed controller board has hardware fault	3. Replace the fan speed controller board and compare the result of two boards
A01	SCR over temperature	1. The fan cannot run normally	1. Check that the fan runs normally
		2. The fan speed controller board has hardware fault	2. Replace the fan speed controller board and compare the result of two boards
A02, A03	Fan 1 over temperature, Fan 2 over temperature	1. The fan cannot run normally	1. Check that the fan runs normally
		2. The AC contactor supplying power for fan has fault or its wire cuts off	2. Check the wiring of AC contactor; detect the auxiliary contact state of AC contactor
		3. Fan speed controller board has hardware fault (the detecting circuit or SCR power supplying circuit has fault)	3. Replace the fan speed controller board and compare the result of two boards
A04	Pressure sensor failure	1. The pressure sensor is not installed or its terminal connection is poor	1. Check the wiring of pressure sensor
		2. Jumper caps are not used at shorting terminals J17 and J18 of current pressure sensor	2. Install the jumper cap when the current pressure sensor is configured
		3. The pressure sensor failed	3. Replace the pressure sensor and compare the result of two boards
		4. The fan speed controller board has hardware fault	4. Replace the fan speed controller board and compare the result of two boards
A05	EEPROM read fault	The fan speed controller board has hardware fault	Replace the fan speed controller board and compare the result of two boards
A06	SCR temperature sensor failure	1. The SCR temperature sensor is not installed or its terminal connection is poor	1. Check the wiring of SCR temperature sensors (J8 SCRTemp, see Figure 3-1 for whose position)
		2. The SCR temperature sensor failed	2. Replace the SCR temperature sensor and compare
		3. The fan speed controller has hardware fault	3. Replace the fan speed controller board and compare the result of two boards
A07	Abnormal frequency	1. The frequency of power supply voltage is wrong 2. The fan speed controller has hardware fault	Replace the fan speed controller board and compare the result of two boards

Appendix 1 Circuit Diagram

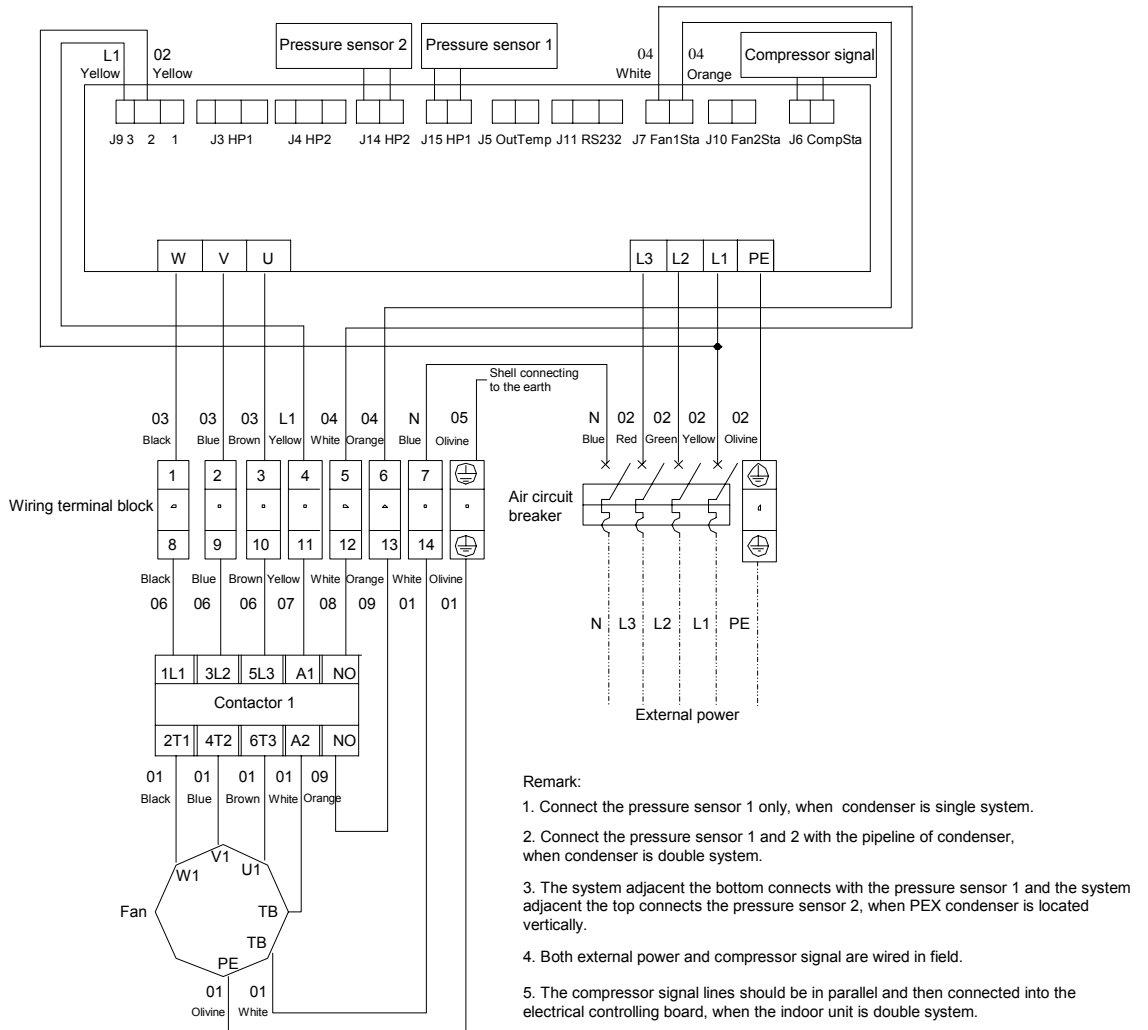

Figure 1 Circuit diagram of the condenser with single fan

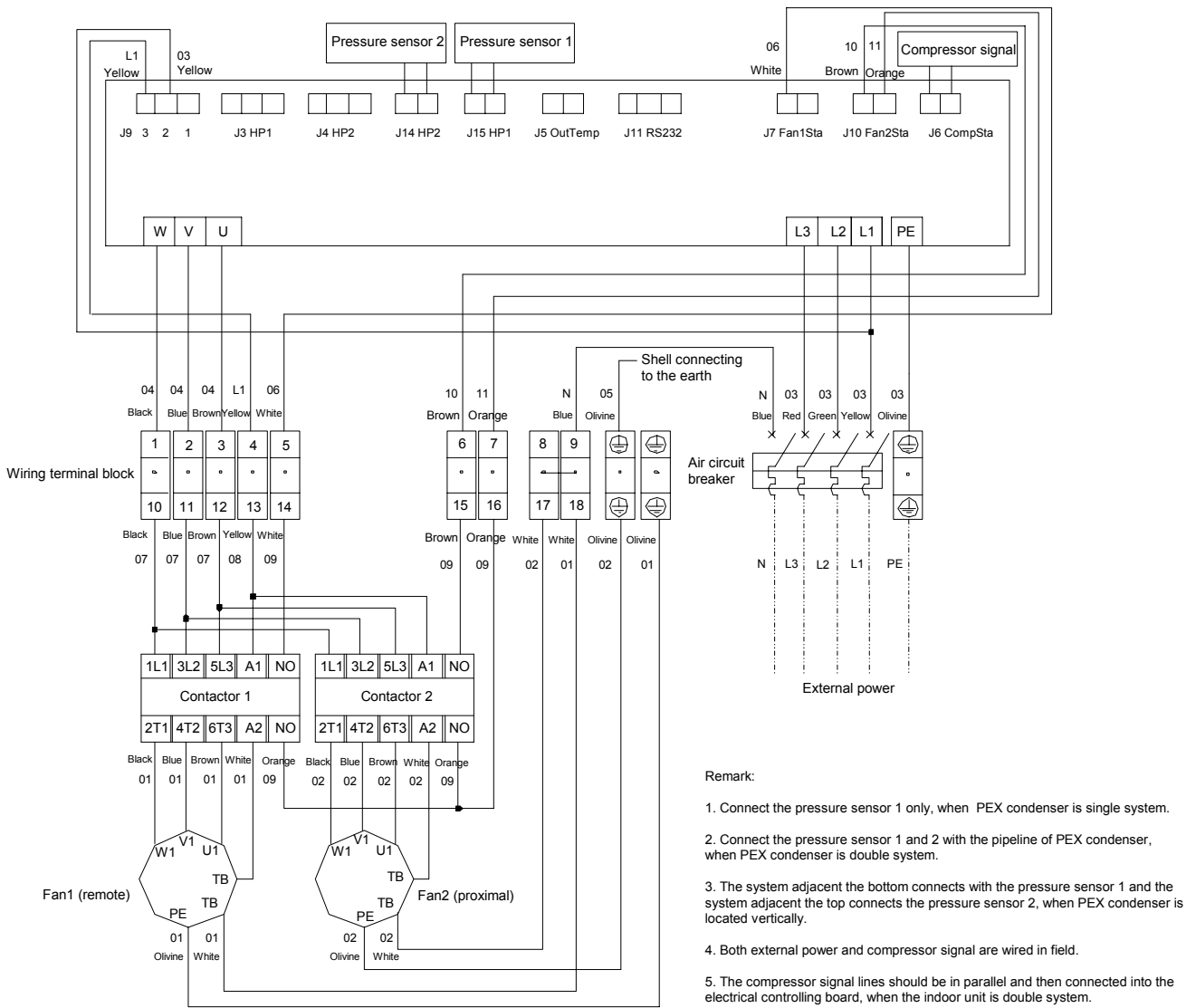

Figure 2 Circuit diagram of the condenser with double fan