

**MCUez FOR
SERIAL DEBUG INTERFACE
USER'S MANUAL**

© Copyright 1997 HIWARE AG; All Rights Reserved

**For More Information On This Product,
Go to: www.freescale.com**

Freescale Semiconductor, Inc.

Important Notice to Users

While every effort has been made to ensure the accuracy of all information in this document, Motorola assumes no liability to any party for any loss or damage caused by errors or omissions or by statements of any kind in this document, its updates, supplements, or special editions, whether such errors are omissions or statements resulting from negligence, accident, or any other cause. Motorola further assumes no liability arising out of the application or use of any information, product, or system described herein; nor any liability for incidental or consequential damages arising from the use of this document. Motorola disclaims all warranties regarding the information contained herein, whether expressed, implied, or statutory, *including implied warranties of merchantability or fitness for a particular purpose*. Motorola makes no representation that the interconnection of products in the manner described herein will not infringe on existing or future patent rights, nor do the descriptions contained herein imply the granting or license to make, use or sell equipment constructed in accordance with this description.

Information contained in this document applies to REVision (0) MCUez.

The computer program contains material copyrighted by Motorola Inc., first published 1997, and may be used only under a license such as the License For Computer Programs (Article 14) contained in Motorola's Terms and Conditions of Sale, Rev. 1/79.

Trademarks

This document includes these trademarks:

MCUez is a trademark of Motorola Inc.

EXORciser is a trademark of Motorola Inc.

The MCUez development, emulation, and debugging application is based on HI-WAVE; a software technology developed by HIWARE. HI-WAVE is a registered trademark of HIWARE AG.

AIX, IBM, and PowerPC are trademarks of International Business Machines Corporation.

SPARC is a trademark of SPARC international, Inc.

Sun and SunOS are trademarks of Sun Microsystems, Inc.

UNIX is a trademark of Novell, Inc., in the United States and other countries, licensed exclusively through X/Open Company, Ltd.

X Window System is a trademark of Massachusetts Institute of Technology.

Motorola and the Motorola logo are registered trademarks of Motorola Inc.

Motorola Inc. is an Equal Opportunity/Affirmative Action Employer.

**For More Information On This Product,
Go to: www.freescale.com**



CONTENTS

CHAPTER 1 GENERAL INFORMATION

1.1 INTRODUCTION 1-1
1.2 OVERVIEW 1-1

CHAPTER 2 INTERFACING YOUR SYSTEM TO A TARGET

2.1 INTRODUCTION 2-1
2.2 SYSTEM POWER 2-2

CHAPTER 3 COMMUNICATION CONFIGURATION

3.1 INTRODUCTION 3-1
3.2 COMMUNICATION DEVICE 3-1
3.3 DATA FORMAT 3-2

CHAPTER 4 DEFAULT TARGET SETUP AND MENUS

4.1 INTRODUCTION 4-1
4.2 SETTING A TARGET 4-2
4.3 THE MCUEZ STATUS BAR FOR THE SDI 4-2
4.4 ADVANCED SDI ENVIRONMENT SETUP 4-3
 4.4.1 SDI Default Environment 4-3
 4.4.2 Parameters Override 4-3
 4.4.3 IMODULE 4-3
 4.4.4 COMDEV 4-3
 4.4.5 SDI Target Startup File 4-3
 4.4.6 SDI Reset Command File 4-4

CHAPTER 5 SDI TARGET COMPONENT MENU ENTRIES

5.1 INTRODUCTION 5-1
5.2 LOADING AN APPLICATION 5-1

5.3 COMMUNICATIONS BAUD RATE	5-1
5.3.1 Communication	5-1
5.3.2 Maximum Baud Rate	5-2
5.3.3 Show Protocol	5-2
5.3.4 MCU Selection	5-2
5.3.5 MCU E-Clock Frequency	5-3
5.3.6 Memory Configuration	5-4

CHAPTER 6 LOADING THE SDI COMPONENT

6.1 INTRODUCTION	6-1
6.2 ON-CHIP HARDWARE BREAKPOINT	6-1
6.3 EEPROM PROGRAMMING	6-1

CHAPTER 7 OPERATING THE EVB WITH THE SDI

7.1 INTRODUCTION	7-1
7.2 OPERATING THE SDI WITH THE MC68HC812A4EVB	7-1
7.3 OPERATING THE SDI WITH THE M68HC912B32EVB	7-1
7.4 EXAMPLES	7-1

CHAPTER 8 SDI COMMANDS

8.1 INTRODUCTION	8-1
8.2 COMMANDS	8-1

CHAPTER 9 OPERATING PROCEDURE

9.1 PERIODIC UPDATE FROM DATA COMPONENT CONTENT	9-1
9.2 PERIODIC UPDATE FROM MEMORY COMPONENT CONTENT	9-1

FIGURE

Figure 1-1. The Serial Device Interface (SDI)	1-1
Figure 2-1. Serial Port Connector	2-1
Figure 3-1. Communication Device Window	3-1
Figure 4-1. Example of project.ini File	4-1



Figure 4-2. Selecting the Motosil Target Component 4-2

Figure 4-3. The SDI Target Menu 4-2

Figure 4-4. SDI Status Bar 4-2

Figure 5-1. Communication Device Window 5-1

Figure 5-2. MCU Selection Window 5-2

Figure 5-3. Setting the MCU Speed 5-3

Figure 5-4. Memory Configuration Window 5-4





CHAPTER 1

GENERAL INFORMATION

1.1 INTRODUCTION

The Serial Device Interface (SDI) is an interface developed by Motorola and used by MCUEz to communicate with an external system called the *target system*.

1.2 OVERVIEW

With this interface, you can download an executable program from the MCUEz environment to an external target system based on a Motorola MCU which will execute the program. You will also have the feedback of the real target system behavior to MCUEz.

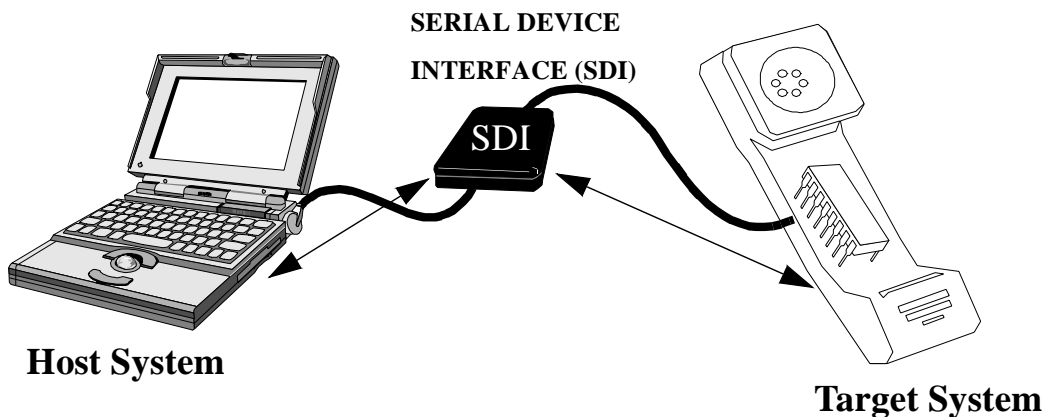

Figure 1-1. The Serial Device Interface (SDI)

MCUEz supervises and monitors the target system's MCU (for example, controls the CPU execution). You can read and write to internal/external memory (even when the CPU is running), single-step run and stop the CPU, and set breakpoints in the code.



CHAPTER 2

INTERFACING YOUR SYSTEM TO A TARGET

2.1 INTRODUCTION

The SDI interface is designed around a serial communication link. The interface is supported by any communication device on your PC or SUN system. The SDI target driver automatically loaded with the SDI target component handles the communication protocol between the SDI and your system. However, you can adapt your target system to the SDI interface. The SDI target system communication is serial. The SDI serial port 6-pin connector for the HC12 target system is shown below. The SDI interface includes two serial port 6-pin connectors. One serial port is the connector used for the HC12.

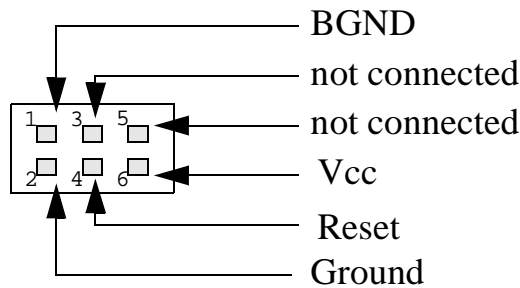

Figure 2-1. Serial Port Connector for the HC12

The serial port connector for the CPU16/32 is shown below. The HC16 and 683xxx chip series use a 10-pin connector as shown below.

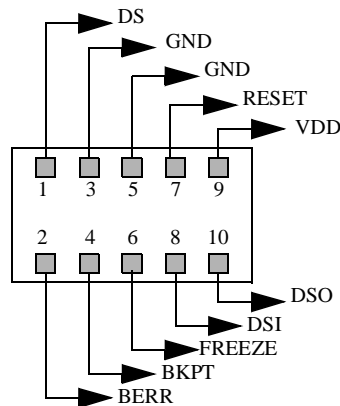

Figure 2-2. Serial Port Connector for the CPU16/32



The communication protocol is defined by Motorola in the *CPU 12 Reference Manual*, section 8 (*Development and Debug Support*).

2.2 SYSTEM POWER

The target system supplies power to the SDI. This power supply must conform to the TTL standard. If it does not conform to the standard, the SDI must have its own power supply.

CHAPTER 3

COMMUNICATION CONFIGURATION

3.1 INTRODUCTION

The communication between the MCUEz application and the SDI interface is set automatically. If the default communication settings are used, the dialog shown in Figure 3-1 pops up. You must make sure that the parameters on your host computer are configured correctly. Also check that the SDI interface is set correctly, otherwise, there will be no communication between the MCUEz application and the target.

3.2 COMMUNICATION DEVICE

If the host and target are not connected, or the connection is not made via the communication device, a dialog box pops up in the MCUEz application as shown below.

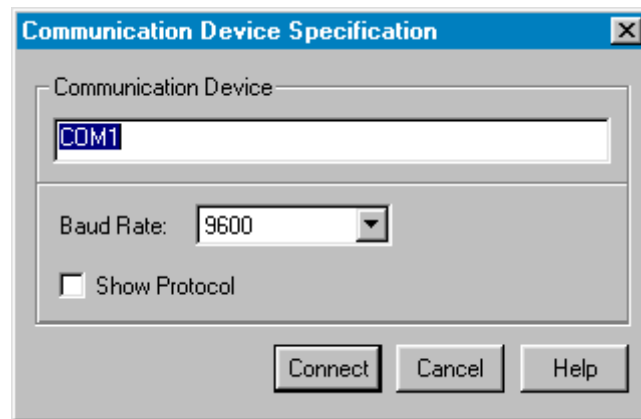

Figure 3-1. Communication Device Window

Choose an available communication device and enter it in the *Communication Device* edit box. Set the baud rate with the drop down menu and click *Connect*. This command only tries the communication device you selected.

If the connection is not established, a message box displays. Once the message box displays, you can try a new communication device. Eventually, the chosen communication device that makes a connection is saved for future debugging sessions. Click *Cancel* to quit the dialog box and the environment. The default device is COM1.



NOTE

The communication device and the baud rate saved through this dialog override the BAUDRATE and COMDEV environment variables of the default.env file.

3.3 DATA FORMAT

The data format used is 8 data bits, 1 stop bit, no parity, and variable baud rate. The default speed is 9600 baud unless defined using the *SDI | Communication...* menu option in the Target menu.



CHAPTER 4

DEFAULT TARGET SETUP AND MENUS

4.1 INTRODUCTION

The *Target* menu loads the SDI target component. It can also be set as a default target in the `project.ini` file. The `project.ini` file is located in the working directory. See the *MCUez Debugger User's Manual* for more information about the `project.ini` file. The following illustration shows an example of a `project.ini` file.

```
[DEFAULTS]

Window0=Source      0   0  50  40
Window1=Assembly   50   0  50  40
Window2=Register   50  40  50  30
Window3=Memory     50  70  50  30
Window4=Data       0   40  50  25
Window5=Command    0   65  50  20
Window6=Module     0   85  50  15

Target=Motosil
```

Figure 4-1. Example of project.ini File

4.2 SETTING A TARGET

The target is usually set in the `project.ini` file as shown in Figure 4-1. If the target is not defined, load the SDI target component by opening the *Component* menu, choosing *Set Target...* and selecting the *Motosil* target component.

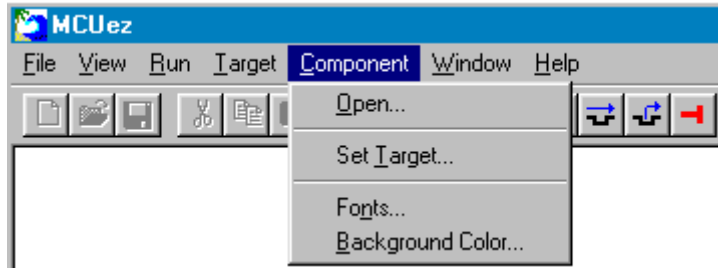

Figure 4-2. Selecting the Motosil Target Component

After loading the Motosil target component, the *Target* menu item is replaced with the *SDI* menu item.

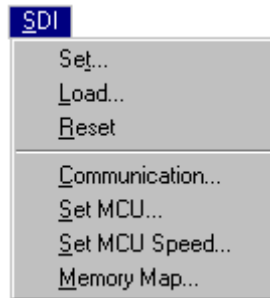

Figure 4-3. The SDI Target Menu

The different items on the SDI menu are explained in detail in the *SDI Target Component Menu Entries* on page 5-1.

4.3 THE MCUEz STATUS BAR FOR THE SDI

When you have loaded the SDI target component, the MCUEz status bar displays the current status of the SDI target component. Reading from the left to the right are the baud rate of the serial communication, the MCUEz running mode, the clock frequency of the target, and also the current MCU-ID.



Figure 4-4. SDI Status Bar



4.4 ADVANCED SDI ENVIRONMENT SETUP

The communication between MCUEz and SDI is automatically set at startup. However, it is possible to manually set your communication and other parameters as described in the following sections.

4.4.1 SDI Default Environment

As with any MCUEz component, you can set parameters for the SDI target component through the `default.env` file which must be located in the working directory. The section shown below is a sample of the `default.env` file concerning the SDI (example).

```
BAUDRATE=57600
IMODULE=SIM
```

4.4.2 Parameters Override

If you do not specify these parameters, the default value is assumed (see below). This default value can be changed individually if needed.

4.4.3 IMODULE

The MCU-ID provides the default values for the integration module. To override these values, you must specify one of the following module types using the `IMODULE` parameter:

SIM, SCIM, RPSCIM, SCIM2, LIM_N_MUX, LIM_MUX, SLIM_N_MUX, SLIM_MUX.

Example: `IMODULE=SIM`

4.4.4 COMDEV

This parameter specifies the device to use between host and SDI. `COM1` is the default communication device for PCs and `/dev/ttya` is the default for UNIX systems. You can set a different device from the following lists:

For a PC: Any valid communication device (`COM1`, `COM2`, etc.).

Example: `COMDEV=COM3`

For SUN: Any valid communication device (`/dev/ttya`, etc.).

Example: `comdev=/dev/ttyb`

4.4.5 SDI Target Startup File

The `startup.cmd` file is executed by MCUEz after the SDI target driver loads. This file must be located in the working directory. You can use any MCUEz command in this file and take advantage of the wide set of commands listed in the *MCUEz User's Guide*.



Example of a `startup.cmd` file content:

```
wb 0x0035 0x00  
wb 0x0012 0x11
```

4.4.6 SDI Reset Command File

The `reset.cmd` file is executed when the Debugger is launched or when you choose *Reset* in the *Target/SDI* menu. This file must be located in the working directory. You can use any MCUEz command in this file.

CHAPTER 5

SDI TARGET COMPONENT MENU ENTRIES

5.1 INTRODUCTION

The following sections describe all SDI target component menu entries.

5.2 LOADING AN APPLICATION

Choose the *SDI | Load...* menu option to load the application to debug, (for example, a .ABS file).

5.3 COMMUNICATIONS BAUD RATE

The baud rate at which the host computer communicates with the SDI must be chosen early in a session, because the system operates most efficiently when the baud rate is at the maximum rate supported by the host computer. This baud rate is set automatically when MCUEz starts to communicate with the SDI. However, you can modify this baud rate as explained below.

5.3.1 Communication

Select the *SDI | Communication...* menu option to display the dialog box shown below. If you know the maximum rate your host supports, select it from the drop down menu (115200 is not supported on the SDI). Otherwise, select 57600. If communication fails, the baud rate reduces automatically until communication works with the host computer.

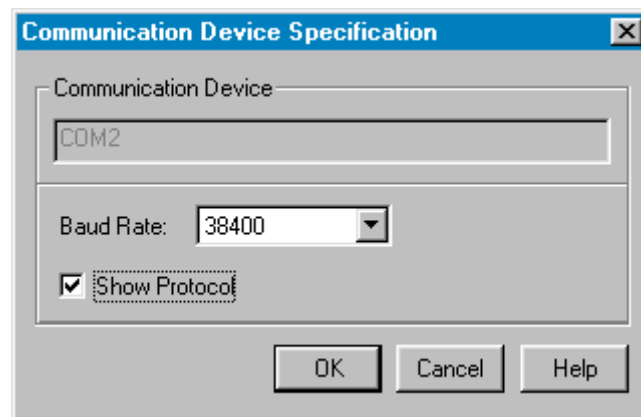

Figure 5-1. Communication Device Window

5.3.2 Maximum Baud Rate

The maximum baud rate depends on the speed and interrupt load of the host computer. On slow notebook computers or on computers running on a network, the maximum baud rate can be as low as 19200. A buffered I/O card allows the maximum rate of 57600 on any host computer. The default value is 9600.

5.3.3 Show Protocol

If the *Show Protocol* box is checked, all the commands and responses sent and received are reported in the command line window. This feature is used by support personnel from Motorola.

5.3.4 MCU Selection

Choose the *SDI | Set MCU...* menu option to open this dialog.

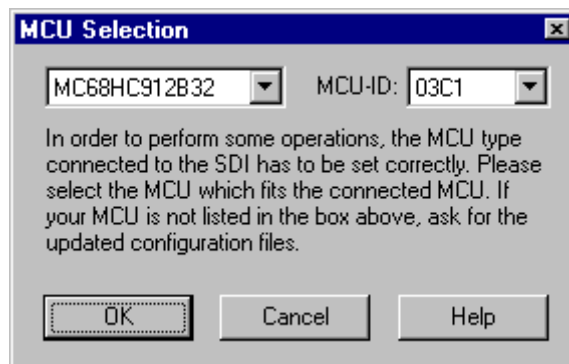

Figure 5-2. MCU Selection Window

This dialog allows you to select the MCU currently used. There are two drop down menus on the Combo controls. They show the currently selected MCU name and MCU-ID. The information will be taken from the MDSEMCU.INI file. If a specific MCU is not found in this file, you must update your installation. This will save your selection to use as the default for the next session.



5.3.5 MCU E-Clock Frequency

Choose the *SDI | Set MCU Speed...* menu option to open this dialog.

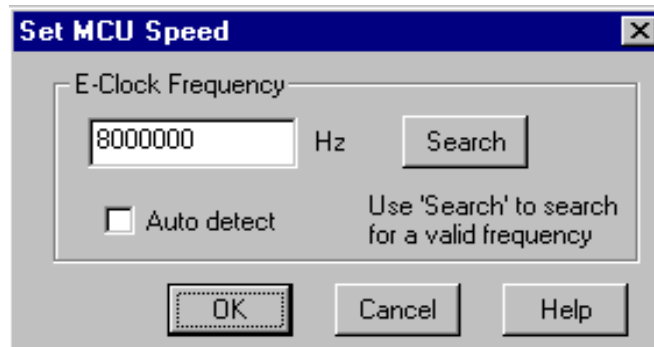

Figure 5-3. Setting the MCU Speed

This dialog shows the current setting of the E-clock frequency to be used by the MCU. This frequency must be known by the SDI for proper communication through the BDM. This is typically half of the crystal oscillator frequency for CPU12.

In the Edit box, you can specify the frequency to be used. When *Select* is clicked, the debugger tries to verify the communication and if it fails, it will search for a valid frequency in the following order:

16 MHz, 8 MHz, 4 MHz, 2 MHz, 1 MHz, 12 MHz, 6 MHz, 3 MHz, 1.5 MHz, 14 MHz, 10 MHz, 7 MHz, 5 Mhz.

If the communication cannot be verified, a message displays.

At startup, the debugger uses the specified frequency. When the debugger fails and the check box *Auto detect* is checked, it will also try to find a fitting frequency. If it was not possible to establish proper communication, an error message displays, followed by this dialog.

Selections are saved and used as defaults for the next session.

5.3.6 Memory Configuration

Choose the *SDI | Memory Map...* menu option to open this dialog.

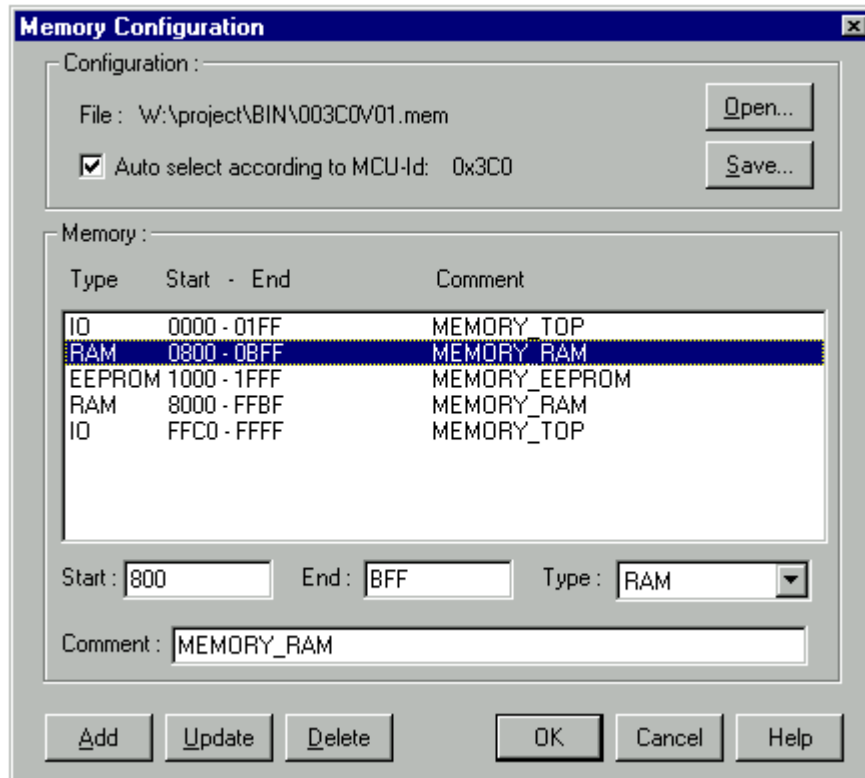

Figure 5-4. Memory Configuration Window

The memory configuration window contains the physical setup of the target. This setup loads automatically if the *Auto select* box is checked. MCUEz identifies the setup through the MCU-ID given in the previous dialog. However, you can modify this configuration, save it, or load a different one. You can also add new fields, remove fields, or edit them.



CHAPTER 6

LOADING THE SDI COMPONENT

6.1 INTRODUCTION

The MCUEz target component monitors the SDI interface. The SDI driver loads when you load the SDI target component. The SDI target DLL is not included in the MCUEz base installation. The SDI target component is loaded through the `project.ini` file or through the *Component | Set Target...* menu option by choosing *Motosil*.

6.2 ON-CHIP HARDWARE BREAKPOINT

An on-chip hardware breakpoint module can be used to implement breakpoints. To invoke this module to take advantage of hardware breakpoints, you must initialize the environment variable `HWBPMODULEADR` in the `default.env` file with the address in memory of the hardware breakpoint module. Make sure that the line is not in remark. If you are not using hardware breakpoints and the associated module, comment out the line shown below:

Example:

```
HWBPMODULEADR=0x20
```

The SDI hardware breakpoint can only handle two breakpoints at the same time. Additional breakpoints will be considered as software breakpoints. If you are debugging your code in flash, you should not set more than two breakpoints.

Some actions like “stepping over” or “stepping out” use one internal breakpoint. For efficient operation reduce the number of hardware breakpoints needed to one.

6.3 EEPROM PROGRAMMING

In order to download code or data into the EEPROM, MCUEz has to know the location of this EEPROM. To identify the location of this EEPROM, you must define the following two environment variables:

EEPROM_START Defines the address of the first byte of the EEPROM memory.

EEPROM_END Defines the address of the last byte of the EEPROM memory.

Example:

```
EEPROM_START=0x0D00
```

```
EEPROM_END=0xFFF
```



This specifies the memory range of the EEPROM as 0xD000 to 0x0FFF. When writing to these addresses, the EEPROM is automatically programmed to download a program or to modify the memory or the variables interactively.

NOTE

The SDI does not currently support Flash programming. This feature is reserved for future use.



CHAPTER 7

OPERATING THE EVB WITH THE SDI

7.1 INTRODUCTION

The SDI can be used together with any target system that is equipped with a Background Debug Connector. The SDI also operates with the M68HC812A4EVB and M68HC912B32EVB HC12 evaluation board. The EVB supports the HC124A and HC129B32 controllers.

7.2 OPERATING THE SDI WITH THE MC68HC812A4EVB

To run the SDI with MC68HC812A4EVB, you must remove the BGND jumper in the EVB, and you must disable the ROM chip (monitor program) by removing the chip select jumper from the ROM socket. You must also make sure that both operating modes, MODA and MODB, are set to low.

However, you can replace the default ROM chips with RAM chips. Consult the *EVB User's Manual* to get the correct setup for the chip select jumper and other jumpers on the EVB.

NOTE

When you connect the SDI cable to the EVB, make sure that the red-colored side of the cable is aligned with the odd-numbered connector pins on the board.

7.3 OPERATING THE SDI WITH THE M68HC912B32EVB

To run the SDI with the M68HC912B32EVB, you must connect the SDI cable to the BDM IN connector on the evaluation board. You must also set the operating mode as EVB or PAD. When you select the PAD operating mode, you can then use the SDI in debugging procedures on the target system. For detailed information, see the *M68HC912B32EVB User's Manual*.

7.4 EXAMPLES

To run MCUEz demo with A4EVB, you must place the jumper in the CSPO pin 2 and 3 on the RAM socket to allocate memory from \$8000. All demo programs delivered on the SDI installation disk can be loaded and run with SDI on the EVB Board.





CHAPTER 8

SDI COMMANDS

8.1 INTRODUCTION

The following sections describe all SDI commands.

8.2 COMMANDS

The SDI incorporates two commands: BAUD and RESET.

BAUD

Short:	baud rate
Syntax:	BAUD [rate]
	<p>rate: Specifies the new baud rate, and must be an integer constant with one of the following specific values (decimal):</p> <p>1200, 2400, 4800, 9600, 19200, 28800, 38400, 57600.</p>

Description:

The **BAUD** command sets or displays the baud rate for communication between the system controller and the host computer. For maximum performance, you must set the baud rate as high as the host computer can accommodate. The maximum rate is 57600; the default baud rate is 9600.

If you do not enter a baud rate, the command displays the Communications Baud Rate Specification dialog window for interactive selection of the baud rate. If the host computer is unable to support the requested baud rate, an “Out of synchronization” alert dialog box with two options displays. If you select the ABORT option, the host software exits to windows. If you choose the RETRY option, the 9600 baud rate is used. You can also select the baud rate dialog window from the menu.

Example: BAUD 57600

Changes the communication baud rate to 57600, the maximum rate.



RESET

Short:	target reset
Syntax:	RESET

Description: Resets the SDI target specified in the hardware reset and executes the `reset.cmd` file. This command can be executed when loading the Command Line Component or in any other command file.

NOTE

Refer to Chapter 5 of the *MCUez Debugger User's Manual* for detailed command line information.



CHAPTER 9

OPERATING PROCEDURE

9.1 PERIODIC UPDATE FROM DATA COMPONENT CONTENT

You can configure the debugger to periodically refresh the Data component, while the application is running. Since the emulator ensures non intrusive access on emulated RAM, your application continues to run in real time.

For the debugger to periodically update the content of the Data component:

- Right click in the Data Component and select the entry 'Mode | Periodical' to open the "Update Rate" dialog box.
- Enter 10 in the Rate edit box and click 'OK'. The content of the Data component will refresh each second.
- Start the application. The Data component content is periodically refreshed during program execution.

NOTE

Due to hardware restrictions, periodic refresh of the Data component is not possible when hardware breakpoints or triggers are used in the emulator.

9.2 PERIODIC UPDATE FROM MEMORY COMPONENT CONTENT

To periodically update the content of the Memory component:

- Right click in the Memory Component and select the entry 'Mode | Periodical' to open the "Update Rate" dialog box.
- Enter 10 in the Rate edit box and click 'OK'. The Memory component content will refresh each second.
- Start the application. The content of the Memory component is periodically refreshed during program execution.

NOTE

Due to hardware restrictions, periodic refresh of Memory component is not possible when hardware breakpoints or triggers are used in the emulator.





INDEX

B	P
BAUD 8-1	Protocol 2-1, 2-2, 5-2
Baud Rate 5-1	
Baud rate 3-2	R
BAUDRATE 3-2, 4-3	RESET 8-2
	Reset.cmd 4-4
C	S
COMDEV 3-2, 4-3	SDI 1-1
Communication 2-1, 5-1	Connection 3-1
Communication Baud Rate 5-1	Default target 4-1
Communication Configuration 3-1	Interfacing 2-1
Communication device 3-1	Loading 6-1
	Memory Configuration 5-4
D	Menu 4-2
Data Format 3-2	Menu entries 5-1
Default.env 3-2, 4-3	Menus 4-1
	Port 2-1
E	Power supply 2-2
Environment variables 4-3	Reset command file 4-4
EVB 7-1	Setup 4-3
EVB Examples 7-1	Startup file 4-3
	Status Bar 4-2
H	Target Configuration 5-1
Hardware reset 8-2	SDI driver 2-1
	Serial communication 2-1
I	Startup.cmd 4-3
IMODULE 4-3	System interfacing 2-1
L	T
Loading an application 5-1	Target 1-1
M	V
MCU 1-1	Variable 4-3
MCU frequency 5-3	
MCU selection 5-2	
mcuez.ini 4-1	
Memory Map... 5-4	
Menus 4-1	
Motosil 4-1	