

SCS-WB INSPIRE

ASSEMBLY AND OPERATION MANUAL

SCS-PC
PREACHER CURL
OPTION

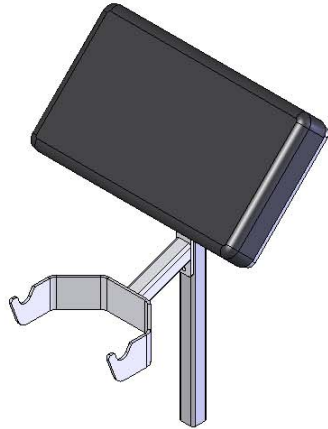

SCS-LE
LEG EXTENSION
OPTION

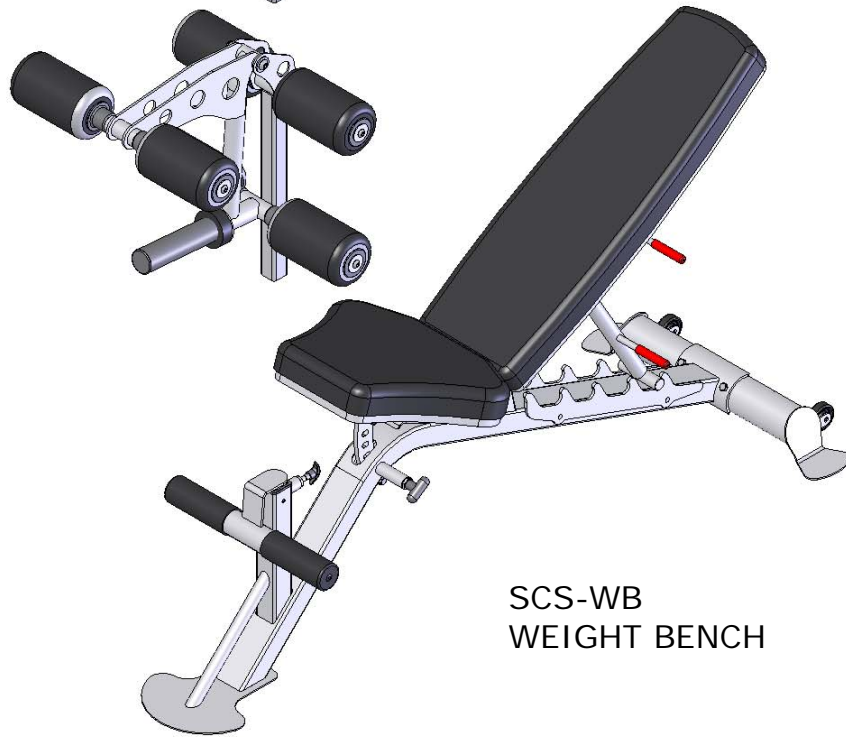
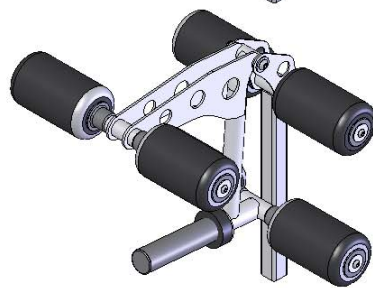

SCS-WB
WEIGHT BENCH

RECORD SERIAL NUMBER HERE

(SCS-PC and SCS-LE sold separately)

CONGRATULATIONS... You've just taken the first step to a healthier and stronger body. This Smith Cage System Weight Bench by Inspire Fitness offers the key to unlocking your body's potential. Regular strength training has been shown to deliver a host of benefits including: increased muscle tone, decreased body fat, improved energy levels, a reduction in stress, and improved cardiac output. Once again, congratulations, you are on your way to improving your self image, overall health, and quality of life.

BEFORE ASSEMBLING YOUR SCS WEIGHT BENCH

IMPORTANT: Read this entire manual before attempting to build or use this equipment. This manual contains step by step instructions for proper assembly.

Use the parts list included in this manual to verify that all parts are accounted for before assembly. If any parts are missing, contact the retailer of this Smith Cage System for replacement parts. Or, call Inspire Fitness at 714-738-1729 or 877-738-1729.

A rubber mat is recommended for use under your Smith Cage System Weight Bench to protect wood flooring or carpeting from damage during assembly and usage.

This Smith Cage System Weight Bench is intended for indoor use only. In addition, garages and screened in porches are not recommended due to high humidity or dust. Rust could form on certain parts in a humid environment resulting in impaired function.

Service of your Smith Cage System Weight Bench should only be performed by an authorized Inspire Fitness retailer. Service performed by anyone else can result in loss of warranty. If you need help finding an authorized retailer, please contact us directly:

Inspire Fitness
637 S. State College Blvd.
Fullerton, CA 92831
Ph: 714-738-1729 or 877-738-1729
Fx: 714-738-1728
www.inspirefitness.net

TABLE OF CONTENTS

Section Description.....	Page
Important Safety Instructions.....	1
Tools Required.....	1
Parts & Hardware List.....	2
Hardware Chart	3
Assembly Instructions, Weight Bench	5
Assembly Instructions, Leg Extension Option	7
Assembly Instructions, Preacher Curl Option	8
General Maintenance Information and Schedule	9
Limited Warranty.....	10

IMPORTANT SAFETY INSTRUCTIONS

Please read this entire manual and familiarize yourself with all decals and warnings before using this Weight Bench.

- **WARNING!** It is necessary to inspect this Weight Bench regularly to maintain safety and proper function. Please use the maintenance schedule included towards the back of this manual. Immediately replace any and all defective or worn parts. Pay special attention to moving parts and connections to accessories. See General Maintenance section for complete details.
- Use this Weight Bench for its intended purpose as described in this Operation Manual or the exercise chart. Do not use attachments not recommended by the manufacturer.
- Make sure bystanders are at least 5 feet away from the Weight Bench while it is in use.
- Keep children off the Weight Bench at all times.
- Keep the Weight Bench away from walls and clear of any obstructions and furniture.
- Stop immediately if you experience shortness of breath, pain, or dizziness during your workout. Inspire Fitness strongly recommends consulting your doctor before starting an exercise program.

TOOLS REQUIRED FOR ASSEMBLY

- Standard socket set (including 9/16" & 3/4" sockets)
- 9/16" wrench
- 3/4" wrench
- Tape Measure
- Rubber Mallet
- 6mm Allen wrench – supplied

PARTS & HARDWARE LIST

WEIGHT BENCH

Item	Parts Description SCS-WB Box	Qty	Qty Rec'd
1	Main Frame Assembly	1	
2	Rear Base Assembly	1	
3	Seat Pad	1	
4	Back Pad	1	
5	Ankle Support	1	
6	Touch-up paint	1	

Item	Hardware in SCS-WB Box	Qty	Qty Rec'd
1	Bolt, 3/8-16 x 1" L	2	
2	Bolt, 3/8-16 x 1 1/2" L	1	
3	Bolt, 3/8-16 x 2 1/4" L	2	
4	Bolt, 3/8-16 x 4" L	2	
5	3/8" Washer	8	
6	3/8-16 Locknut	2	
7	3/8-16 Thin Locknut	1	
8	5/8" Barrel Spacer	1	

LEG EXTENSION OPTION

	Parts Description SCS-LE Box		
1	Leg Extension Assembly	1	
2	Roller Shaft, 1" diameter	2	
3	Roller Shaft, 1 1/4" diameter	1	
4	Foam Roller with Collar	4	
5	Foam Roller	2	
6	Plastic Washer	8	
7	Touch-up Paint	1	

	Hardware in SCS-LE Box		
1	Bolt, 3/8-16 x 1" L (Button Head with Blue Dot)	6	
2	3/8" x 1 1/2" Washer	6	
3	6mm Allen Wrench	1	

PREACHER CURL OPTION

	Parts Description SCS-PC Box		
1	Weight Support bracket	1	
2	Preacher Curl Extension	1	
3	Arm Pad	1	
4	Touch-up Paint	1	

	Hardware in SCS-PC Box		
1	Bolt, 3/8-16 x 1" L	2	
2	Bolt, 3/8-16 x 2 1/2" L	2	
3	3/8" Washer	6	
4	3/8-16 Locknut	2	

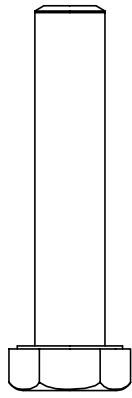
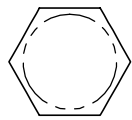
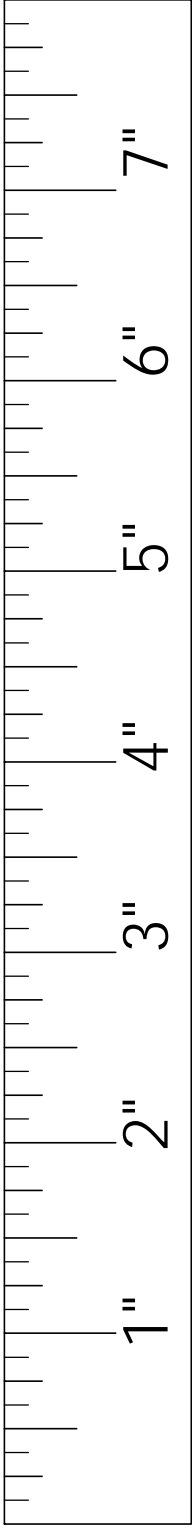

3/8" DIA. Bolt

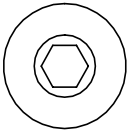

3/8" DIA. Button Head Bolt

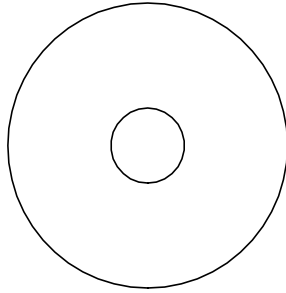
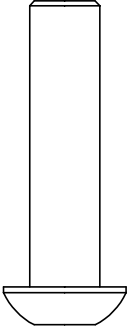

3/8" x 1 1/2" Dia. Washer

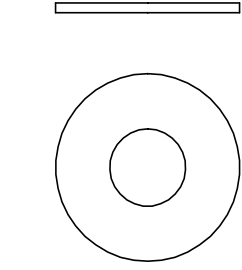

3/8" Washer

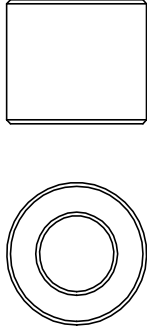

5/8" Barrel Spacer

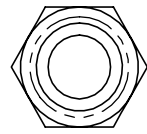

3/8" Locknut

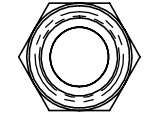

3/8" Thin Locknut



Allen Wrench

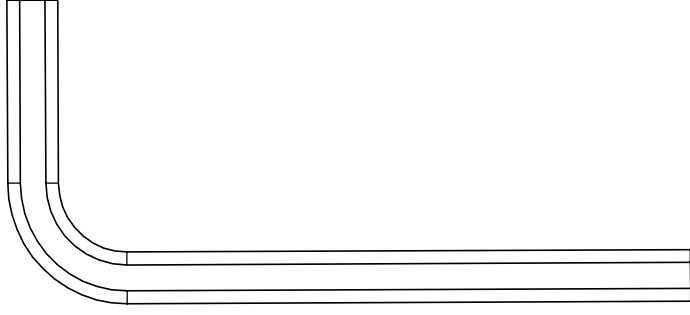

ACTUAL PARTS MAY BE SMALLER OR LARGER THAN SHOWN

ASSEMBLY INSTRUCTIONS



Weight Bench Assembly Instructions

Step 1

- 2 – 3/8" x 4" Hex Bolts
- 4 – 3/8" Flat Washers
- 2 – 3/8" Lock Nuts

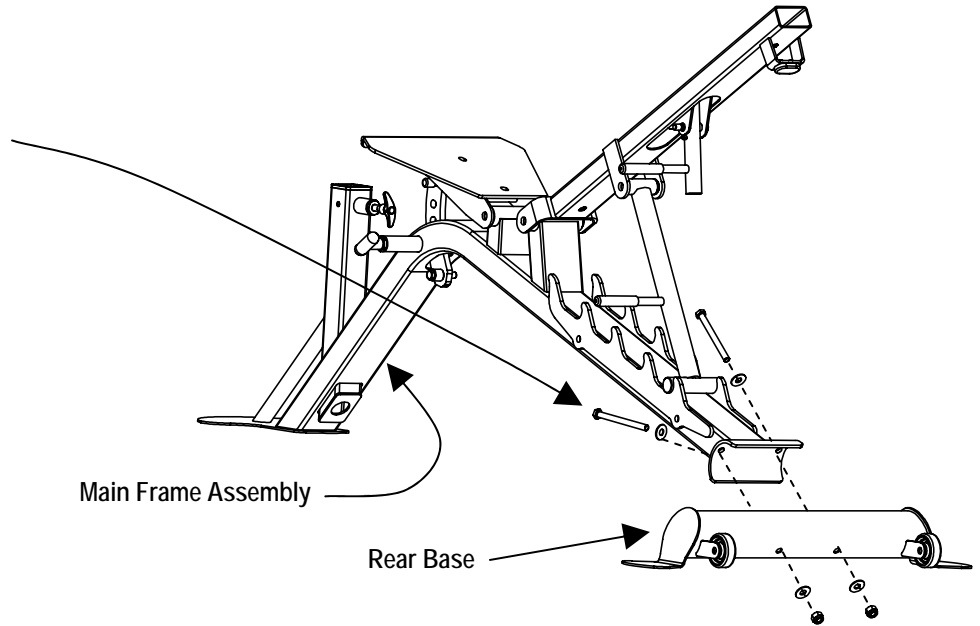

Step 2

- 2 – 3/8" x 2 1/4" Hex Bolts
- 2 – 3/8" Flat Washers

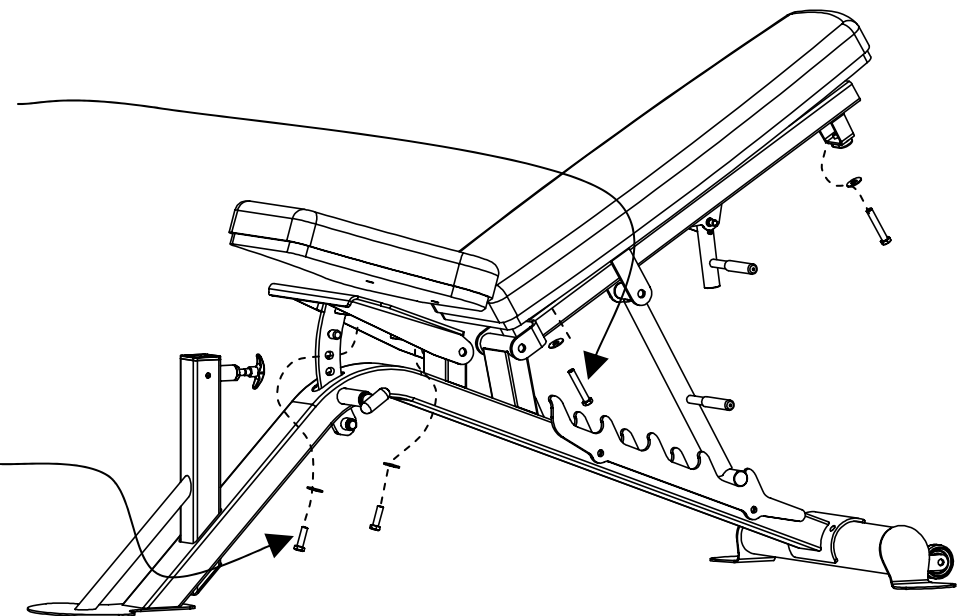

Step 3

- 2 – 3/8" x 1" Hex Bolts
- 2 – 3/8" Flat Washers

Step 1: Attach Rear Base to Main frame Assembly using:

Two (3/8" x 4" Hex Bolts)
Four (3/8" Flat Washers)
Two (3/8" Lock Nuts)

Step 2: Attach Back Pad to Back Support and Seat Pad to Seat base using:

Two (3/8" x 2 1/4" Hex Bolts)
Two (3/8" Flat Washers)

Step 3: Attach Seat Pad to Seat Base using:

Two (3/8" x 1" Hex Bolts)
Two (3/8" Flat Washers)

Note: Wrench Tighten Everything Now

Step 4

- 1 - 3/8" x 1 1/2" Hex Bolt
- 1 - 5/8" Barrel Spacer
- 1 - 3/8" Thin Lock Nut

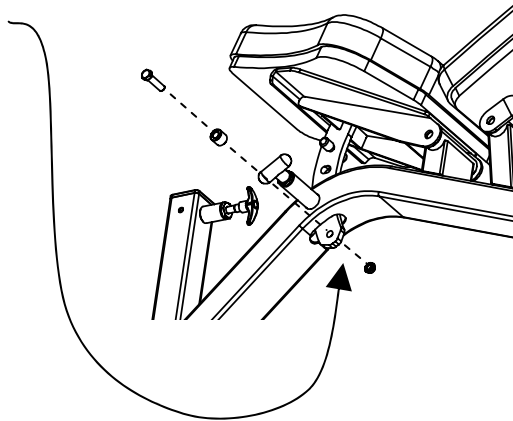

Step 4: Install Seat Pivot Restraint Bolt and 5/8" Barrel Spacer into the last hole in the seat base selector stem using:

- One (3/8" x 1 1/2" Hex Bolt)**
- One (5/8" Barrel Spacer)**
- One (3/8" Thin Lock Nut)**

Note: Wrench Tighten Now

Leg Extension Option Assembly Instructions

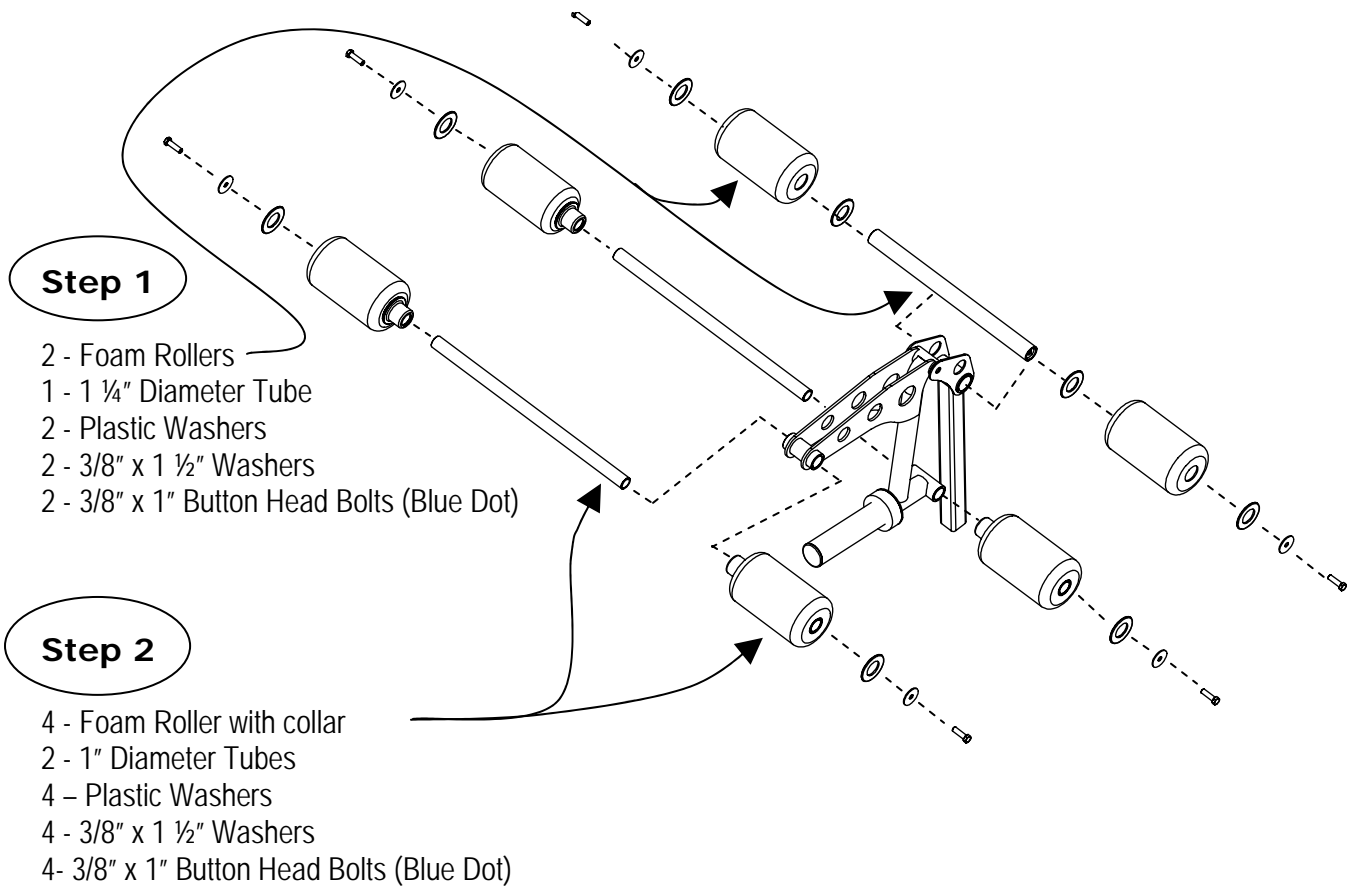

Step 1: Assemble Two Foam Rollers onto the 1 1/4" Diameter Tube using:

Four (Plastic washers)
Two (3/8" x 1" Button Head Bolts with Blue Dot)
Two (3/8" x 1 1/2" Flat Washers)

Step 2: Assemble Four Foam Roller Assemblies with collar onto the 1" Diameter Tubes using:

Four (Plastic Washers)
Four (3/8" x 1" Button Head Bolts with Blue Dot)
Four (3/8" x 1 1/2" Flat Washers)

(Wrench Tighten Bolts Now)

Note: "(Blue Dot)" means there is a blue dot of thread locking compound on the bolt thread.

Preacher Curl Option Assembly Instructions

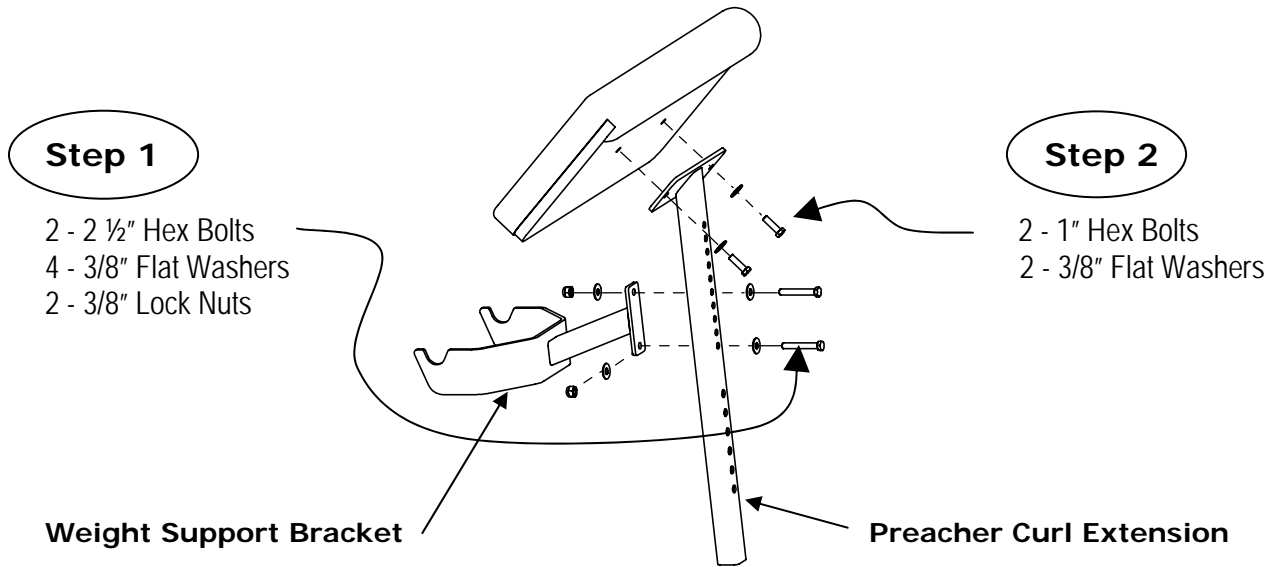

Step 1: Attach the Weight Support Bracket to the Preacher Curl Extension Using:

Two (3/8" x 2 1/2" Hex Bolts)
Four (3/8" Flat Washers)
Two (3/8" Lock Nuts)

Note: There are several sets of mounting holes in the Preacher Curl Extension to allow the user to position the Weight Support Bracket at the most comfortable height.

Step 2: Attach the Arm Pad to the Preacher Curl Extension Using:

Two (3/8" x 1" Hex Bolts)
Two (3/8" Flat Washers)

Note: Wrench Tighten Now

Training Tips

CONSULT A PHYSICIAN BEFORE STARTING ANY EXERCISE PROGRAM

1. **Always warm up** before you start weight training. This helps get your muscles warm and prevents injury. You can warm up with light cardio or by doing a light set of each exercise before going to heavier weights.
2. **Control the weight.** Always work with a weight that you can handle through a full range of motion. Slow and steady movements are recommended.
3. **Breathe.** Don't hold your breath during your set. Holding your breath builds internal pressure which increases your change for broken blood vessels, as well as a hernia.

GENERAL MAINTENANCE INFORMATION AND SCHEDULE

- Regularly inspect product for loose hardware, wear, or damaged parts. If wear or damage exists, replace immediately.
- Replace damaged or worn Seat Pad, Back Pad, and Foam Rollers immediately.
- Do not use or store equipment outdoors.
- Locate and familiarize yourself with all warning decals on the Weight Bench and Options.

ROUTINE	HOME MAINTENANCE	ENTRY DATE							
Clean: Seat and Back Pads, Foam Rollers	WEEKLY								
Inspect: All Nuts and Bolts. Tighten if Needed	3 MONTHS								
Inspect: All Decals	3 MONTHS								
Clean and Wax: All Glossy Finishes	YEARLY								

LIMITED WARRANTY



In-Home Lifetime Warranty.

This Warranty applies only in the United States to Inspire strength products manufactured or distributed by Health In Motion LLC. The warranty period to the original purchaser is lifetime of the original purchaser.

Health In Motion warrants that the Product you have purchased for non-commercial, personal, family or household use from Health In Motion LLC or from an authorized Health In Motion reseller is free from defects in materials or workmanship under normal use during the warranty period. Your sales receipt, showing the date of purchase of the Product, is your proof of the date of purchase. This warranty extends only to you, the original purchaser. It is not transferable to anyone who subsequently purchases the Product from you. It excludes expendable parts such as paint and finish. This Warranty becomes VALID ONLY if the Product is assembled / installed according to the instructions / directions included with the Product.

Replacement and repair of parts.

During the warranty period Health In Motion will at no additional charge, repair or replace the Product if it becomes defective, malfunctions, or otherwise fails to conform with this Warranty under normal non-commercial, personal, family, or household use. In repairing the product Health In Motion may replace defective parts with, at the option of Health In Motion, serviceable used parts that are equivalent to new parts in performance, or new parts. All exchanged parts and Products replaced under this warranty will become the property of Health In Motion. Health In Motion reserves the right to change manufacturers and or specification of any part to cover any existing warranty.

Service procedures.

To obtain warranty parts, you must return the parts to Health In Motion or an authorized Health In Motion retailer in its original container (or equivalent). You must pre-pay any shipping charges, taxes, or any other charges associated with transportation of the Product. In addition, you are responsible for insuring any Product shipped or returned. You assume the risk of loss during shipment. You must present Health In Motion with proof-of-purchase documents (including the date of purchase, Model, and Serial Number). Any evidence of alteration, erasing or forgery of proof - of-purchase documents will be cause to void this Warranty.

Conditions and Exceptions.

This Warranty does not extend to any Product not purchased from Health In Motion LLC or from an authorized Health In Motion reseller. This Warranty does not extend to any Product that has been damaged or rendered defective; (a) as a result of accident, misuse, or abuse; (b) by the use of parts not manufactured or sold by Health In Motion; (c) by modification of the Product; (d) as a result of service by anyone other than Health In Motion, or an authorized Health In Motion warranty service provider; (e) product that has not been properly maintained (follow maintenance schedule found on product). Should any product submitted for Warranty service be found to be ineligible, an estimate of repair cost will be furnished and the repair will be made if requested by you upon Health In Motion receipt of payment or acceptable arrangement of payment.

Disclaimer

EXCEPT AS EXPRESSLY SET FORTH IN THIS WARRANTY HEALTH IN MOTION MAKES NO OTHER WARRANTIES; EXPRESSED OR IMPLIED INCLUDING ANY IMPLIED WARRANTIES OF MERCHANTABILITY AND FITNESS FOR A PARTICULAR PURPOSE. HEALTH IN MOTION EXPRESSLY DISCLAIMS ALL WARRANTIES NOT STATED IN THIS WARRANTY. ANY IMPLIED WARRANTIES THAT MAY BE IMPOSED BY LAW ARE LIMITED TO THE TERMS OF THIS WARRANTY. NEITHER HEALTH IN MOTION NOR ANY OF ITS AFFILIATES SHALL BE RESPONSIBLE FOR INCIDENTAL OR CONSEQUENTIAL DAMAGES. HEALTH IN MOTION IS NOT RESPONSIBLE FOR THE REPAIR OR REPLACEMENT OF ANY PARTS THAT HEALTH IN MOTION DETERMINES HAVE BEEN SUBJECTED AFTER THE DATE OF MANUFACTURE TO ALTERATION, NEGLIGENCE, ABUSE, MISUSE, NORMAL WEAR & TEAR, ACCIDENT, DAMAGE DURING TRANSIT OR INSTALLATION, FIRE, FLOOD, OR ANY ACT OF GOD. SOME STATES DO NOT ALLOW LIMITATIONS ON HOW LONG AN IMPLIED WARRANTY LASTS OR THE EXCLUSION OR LIMITATION OF INCIDENTAL OR CONSEQUENTIAL DAMAGES, SO THE ABOVE LIMITATIONS OR EXCLUSION MAY NOT APPLY TO YOU. This Warranty gives you specific legal rights and you may also have other rights that may vary from state to state. This is the only express warranty applicable to Health In Motion's "Inspire" branded strength products. Health In Motion neither assumes nor authorizes anyone to assume for it any other express warranty.