

NC-811 PC/104 Ethernet Module

USER'S MANUAL

COPYRIGHT NOTICE

Thank you for purchasing our high performance Ethernet Adapter (NC-811) This guide is to provide the installation and usage of The NC-811 for network installers or users. The Product combines three type of Ethernet cabling-RJ45, connectors for maximum flexibility. Extensive driver support for commonly used network operating systems is available.

This manual is copyrighted 2001. You may not reproduce by any way.

1-1 Hardware Overview

The Product is a 16-bit Ethernet PC/104 Module which offers users the highest performance in the Full-Duplex architecture. It is a PC/104 bus and plug & play + jumperless + Full-Duplex Ethernet card, you can use the enhance drivers provided for the LAN cards or the same Novell NE2000 drivers. Furthermore, by using the single Ethernet Chipset, this card consumes only 10% of the power of a typical Ethernet card so that you can keep your computer's "Energy Star Logo" by using this Green Ethernet Card. The Product with RJ45 connector. It allows users to configure the hardware by using software, or Plug & Play mode and the auto-setup feature makes the Ethernet Card to be truly "Plug & Play" .

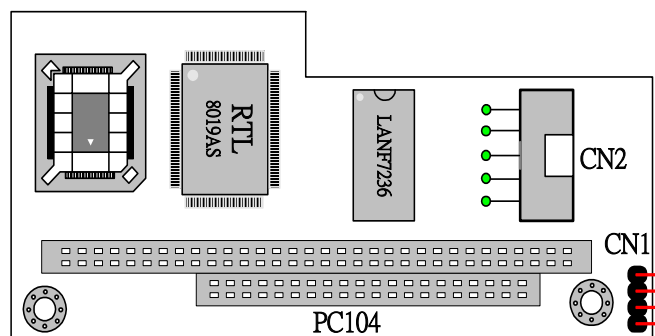

CN1: LED function Connector

Pin1	VCC	Pin2	LED0
Pin3	VCC	Pin4	LED1

CN2: Ethernet Connector

PIN1	TX+	PIN2	TX-
PIN3	AX+	PIN4	NC
PIN5	NC	PIN6	AX-
PIN7	NC	PIN8	NC
PIN9	NC	PIN10	NC

1-2 Technical Specifications

Topology	:	Star / Bus
Protocol	:	CSMA / CD (Carrier Sense Multiple Access with Collision Detection) .
Connector Supported	:	RJ-45.
Standard	:	IEEE 802.3 10 Base-T
Transmission Rate	:	10Mbps or 20Mbps
Hardware	:	PC/104 compliant PCs
Distance	:	UPT cable 100 meters for link segment . 500 multiple Hubs .
IRQ Line	:	2, 3, 4, 5, 10, 11, 12, 15
I/O Address	:	200-21FH , 220 – 23FH , 240-25FH , 260 –27FH 280-29FH , 2A0– 2BFH , 2C0-2DFH ,2E0 –2FFH 300-31FH , 320 – 33FH , 340-35FH , 360 –37FH 380-39FH , 3A0– 3BFH , 3C0-3DFH ,3E0 –3FFH
Software	:	Novell NetWare 3.X, 4.X, NDIS driver for Microsoft LAN Manager, Windows for Workgroups, Microsoft Windows NT, Packet driver for TCP/IP. Win95, Win98, WinXp, SCOUNIX driver, Artisoft Lantastic driver.
Temperature	:	0°C to 70°C (Operating) -65°C to 140°C (Storage)
Humidity	:	10% to 90% (Non –condensing) .
Power	:	1.5 Watts (MAX) .

1-3 Features & Benefits

- 100-pin PQFP
- RTL8019 software compatible
- Supports PnP auto detect mode
- Compliant to Ethernet II and IEEE802.3 10Base5, 10Base2, 10BaseT
- Software compatible with NE2000 on both 8 and 16-bit slots
- Supports Microsoft's Plug and Play configuration for jumperless mode
- Supports Full-Duplex Ethernet function to double channel bandwidth
- Built-in data prefetch function to improve performance
- Supports auto polarity correction for 10BaseT
- Use 9346 (64*16-bit EEPROM) to store resource configurations and ID parameters
- Support 8 IRQ and 16 level I/O address.
- 16-bit high performance PC/104 Module Ethernet Card.
- Support Netware ODI & IPX, NDIS driver for LAN Manager, Microsoft Windows for Workgroups, Microsoft NT, Win95, Win98, WinXp, SCOUNIX driver & Packet driver for TCP/IP.
- Provides diagnostic software and two LEDs to indicate network activity.
- 16k byte SRAM built in 8019AS
- Support Plug & Play Full-Duplex (UPT only) function.
- Using turbo drivers to enhance transfer rate.
- Configuration by software.
- Plug & Play, auto-setup IRQ and I/O address.
- Media type auto detection RJ-45

Warning:

Stresses beyond those listed under "Absolute Maximum Ratings" may cause permanent damage to the device. These are stress ratings only.

Functionality at or above these limits is not recommended and extended exposure to "Absolute Maximum Ratings" may affect device reliability.