

Kramer Electronics, Ltd.



USER MANUAL

Model:

908

40W Per Channel Stereo Audio Amplifier

Contents

1	Introduction	1
2	Getting Started	1
2.1	Quick Start	2
3	Overview	3
4	Your 908 Stereo Amplifier	4
5	Connecting the 908 Stereo Amplifier	5
5.1	Connect the 10V CONTROL Port to an External Controller	6
5.2	Connecting a PC	7
5.3	Connecting the 908 via the Ethernet Port	7
6	Operating the 908	9
6.1	Using the Front Panel Buttons	9
6.2	Using Serial Commands	9
6.3	Using the Embedded Web Server	9
6.4	Using the RC-IR3 Infrared Remote Controller	14
7	Updating the 908 Firmware	14
8	Default Communication Parameters	14
9	Technical Specifications	15
10	908 Commands in Protocol 3000	16
10.1	Operating Commands	16
10.2	Help Commands	16
10.3	Device Initiated Messages	16
10.4	Result and Error Codes	16
10.5	Basic Routing Commands	17
10.6	Audio Parameters Commands	17
10.7	Identification Commands	18
10.8	Network Setting Commands	19
10.9	Machine Information Commands	19
10.10	Protocol 3000 Syntax	20
10.10.1	Host Message Format	20
10.10.2	Simple Command	20
10.10.3	Command String	20
10.10.4	Device Message Format	20
10.10.5	Device Long Response	20
10.10.6	Command Terms	21
10.10.7	Entering Commands	21
10.10.8	Command Forms	22
10.10.9	Command Chaining	22
10.10.10	Maximum String Length	22

Figures

Figure 1: 908 40W Per Channel Stereo Audio Amplifier	4
Figure 2: Connecting the 908 40W Per Channel Stereo Audio Amplifier	6
Figure 3: Connecting the 10V VOL Terminal Block Connector	6
Figure 4: Connecting to a PC	7
Figure 5: Local Area Properties Window	8
Figure 6: Internet Protocol (TCP/IP) Properties Window	8
Figure 7: Java Test Page Success Message	10
Figure 8: Entering the IP Number in the Address Bar	10
Figure 9: Loading the Embedded Web Server	11
Figure 10: First Time Security Warning	11
Figure 11: The 908 Control Window	12
Figure 12: Control Settings	13
Figure 13: Ethernet Settings	13

Tables

Table 1: 908 40W Per Channel Stereo Audio Amplifier Functions	4
Table 2: Default Communication Parameters	14
Table 3: 908 Technical Specifications	15

1 Introduction

Welcome to Kramer Electronics! Since 1981, Kramer Electronics has been providing a world of unique, creative, and affordable solutions to the vast range of problems that confront the video, audio, presentation, and broadcasting professional on a daily basis. In recent years, we have redesigned and upgraded most of our line, making the best even better! Our 1,000-plus different models now appear in 11 groups¹ that are clearly defined by function.

Thank you for purchasing the Kramer MegaTOOLS® **908 40W Per Channel Stereo Audio Amplifier**, which is ideal for:

- Presentation rooms and multimedia applications for quick, local audio amplification
- Personal audio listening (for example, a PC and portable CD player)

The package includes the following items:

- **908 40W Per Channel Stereo Audio Amplifier**
- Kramer **RC-IR3** Infrared Remote Control Transmitter (including the required battery and a separate user manual)
- Power supply (24V DC)
- This user manual²

2 Getting Started

We recommend that you:

- Unpack the equipment carefully and save the original box and packaging materials for possible future shipment
- Review the contents of this user manual
- Use Kramer high-performance high-resolution cables³

1 GROUP 1: Distribution Amplifiers; GROUP 2: Switchers and Matrix Switchers; GROUP 3: Control Systems; GROUP 4: Format/Standards Converters; GROUP 5: Range Extenders and Repeaters; GROUP 6: Specialty AV Products; GROUP 7: Scan Converters and Scalers; GROUP 8: Cables and Connectors; GROUP 9: Room Connectivity; GROUP 10: Accessories and Rack Adapters; GROUP 11: Sierra Products

2 Download up-to-date Kramer user manuals from our Web site at <http://www.kramerelectronics.com>

3 The complete list of Kramer cables is on our Web site at <http://www.kramerelectronics.com>

2.1 Quick Start

This quick start chart summarizes the basic setup and operation steps.

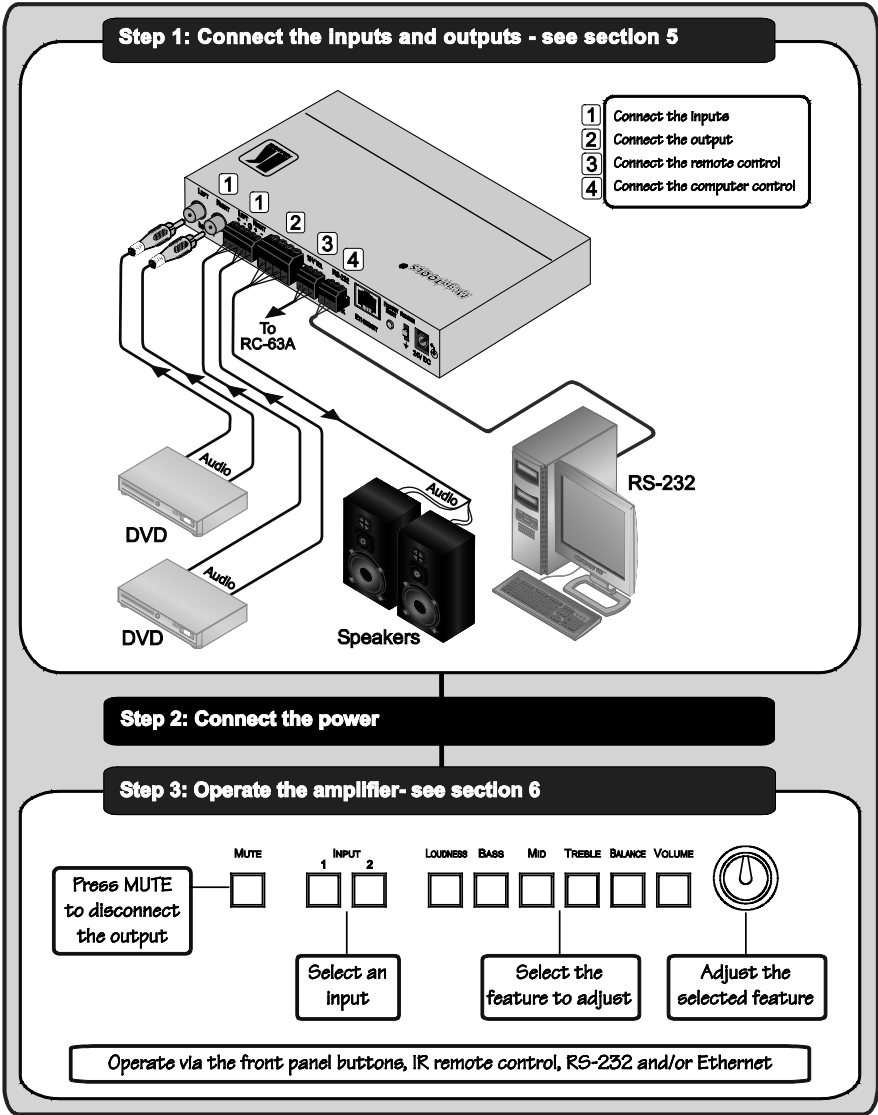

3 Overview

The Kramer **908** is a high-performance audio amplifier for line-level stereo audio signals. It accepts either a stereo audio signal on RCA connectors or a balanced stereo audio signal on a terminal block connector. It delivers a speaker output of 2x40 watts RMS per channel into an 8Ω load on a 10A 4-pin terminal block connector. The **908** features:

- Two input selector buttons and a mute button
- One gain knob for adjusting the audio output levels for loudness, bass, middle, treble, balance and the volume
- A USB connector for firmware upgrade
- RS-232 and Ethernet ports
- A 10V control port for adjusting the audio gain via an external connector¹

The **908** can be controlled:

- Directly, via the front panel push buttons and adjustment knob
- By RS-232 serial commands transmitted by a touch screen system, PC, or other serial controller
- Via an external 10V controller (for volume)
- Via the Ethernet using the embedded Web server
- Remotely, from the infrared remote control transmitter

The **908** is housed in a Kramer MegaTOOLS™ enclosure and is fed by a 24V DC power supply.

To achieve the best performance:

- Use only good quality connection cables² to avoid interference, deterioration in signal quality due to poor matching, and elevated noise levels (often associated with low quality cables).
- Avoid interference from neighboring electrical appliances that may adversely influence signal quality and position your Kramer **908** away from moisture, excessive sunlight and dust

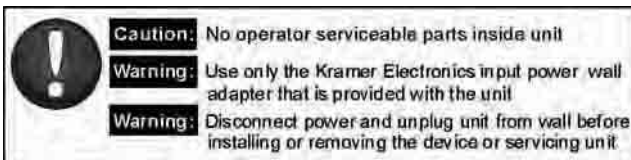

¹ For example, the Kramer RC-63A

² Available from Kramer Electronics on our Web site at <http://www.kramerelectronics.com>

4 Your 908 Stereo Amplifier

Figure 1 and Table 1 define the 908.

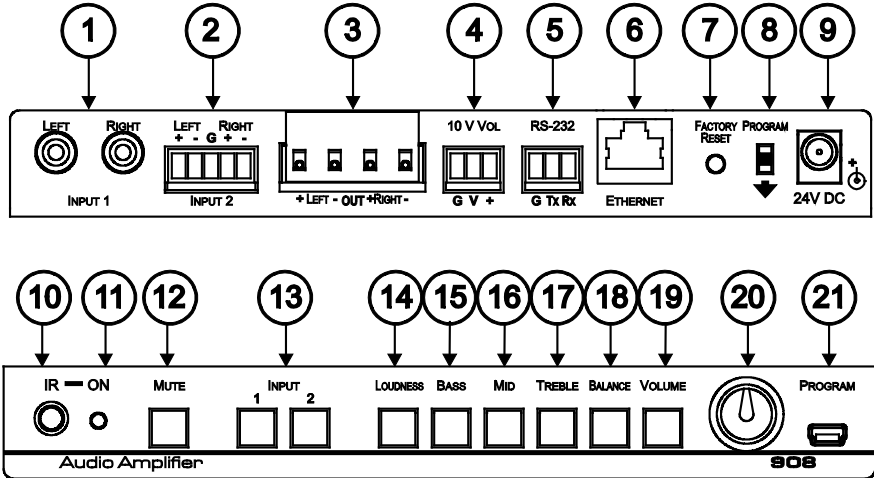

Figure 1: 908 40W Per Channel Stereo Audio Amplifier

Table 1: 908 40W Per Channel Stereo Audio Amplifier Functions

#	Feature	Function
1	INPUT 1 L and R RCA Connectors	Connect to the left and right unbalanced stereo analog audio acceptor
2	INPUT 2 Terminal Block Connector	Connect to the balanced stereo audio source
3	OUTPUT Terminal Block Connector	Connect to a balanced stereo acceptor (speakers)
4	10V VOL G, V, + Terminal Block Connector	Connect to a controller ¹ to adjust the volume via the controller
5	RS-232 G Tx Rx Terminal Block Connector	Control connector
6	ETHERNET Port	Connects to your LAN ²
7	FACTORY RESET Button	Press to return the device to its factory default settings
8	PROGRAM Switch	Switch down before performing a firmware upgrade, leave up (the default) for normal operation
9	24V DC Connector	+24V DC for powering the unit
10	IR IN Receiver	Accepts IR remote commands
11	ON LED	Illuminates green when receiving power, flashes when receiving IR commands
12	MUTE Button	Press to disable/enable the audio output. The button illuminates when the audio output is disabled

¹ For example, the Kramer RC-63A

² Local Area Network (that is, computers sharing a common communications line or wireless link, which often share a server within a defined geographic area)

#	Feature	Function
13	<i>INPUT SELECTOR</i> Buttons	Press to select the input audio source 1 or 2
14	<i>LOUDNESS</i> Button	Press to select the loudness adjustment, adjust with the level knob
15	<i>BASS</i> Button	Press to select the bass adjustment, adjust with the level knob
16	<i>MID</i> Button	Press to select the mid range adjustment, adjust with the level knob
17	<i>TREBLE</i> Button	Press to select the treble adjustment, adjust with the level knob
18	<i>BALANCE</i> Button	Press to select the balance between right and left speakers, adjust with the level knob
19	<i>VOLUME</i> Button	Press to select the volume adjustment, adjust with the level knob
20	Level Adjustment Knob	Increase and decrease the level of the previously selected function
21	<i>PROGRAM (USB)</i> Connector	Connect to a computer to upgrade the firmware

5 Connecting the 908 Stereo Amplifier

To connect the **908**, as illustrated in the example in [Figure 2](#), do the following:

1. Connect an unbalanced stereo audio source (for example, the unbalanced stereo audio output of a DVD player) to the L and R INPUT 1 RCA connectors.
2. Connect a balanced stereo audio source (for example, the balanced stereo audio output of a DVD player) to the INPUT 2 terminal block connector.
3. Connect the OUTPUT terminal block to a pair of loudspeakers: Connect the “L+” and the “L-” terminal block connectors to the left loudspeaker, and the “R+” and the “R-” terminal block connectors to the right loudspeaker. **Do not ground the loudspeakers.**
4. Connect the 24V DC power adapter to the power socket and connect the adapter to the mains electricity (not shown in [Figure 2](#)).
5. If required, connect:
 - The 10V CONTROL terminal block connector to an external controller¹ (see section [5.1](#))
 - The RS-232 port to a PC and/or serial controller (see section [5.2](#))
 - The Ethernet port to a PC or a network hub or router (see section [5.3](#))

¹ For example, the Kramer RC-63A

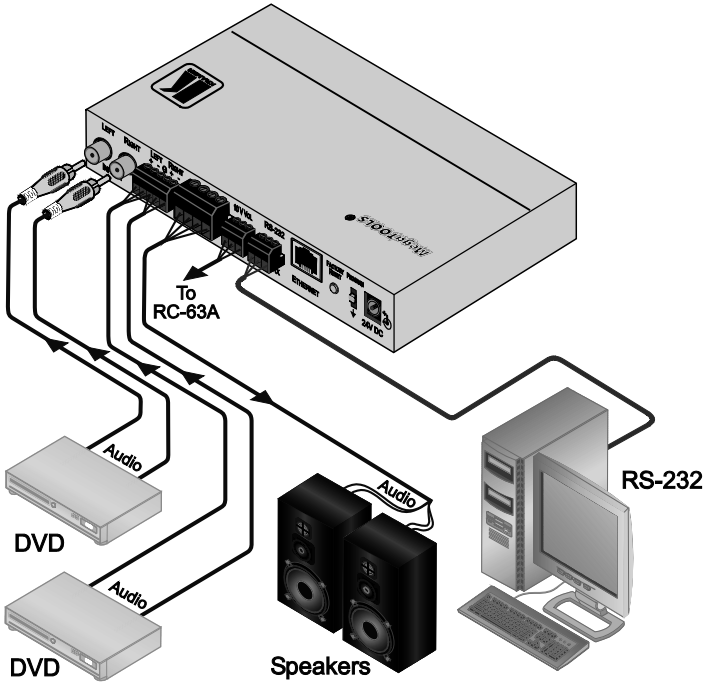

Figure 2: Connecting the 908 40W Per Channel Stereo Audio Amplifier

5.1 Connect the 10V CONTROL Port to an External Controller

You can connect the **908** 10V VOL terminal block connector to a controller (for example, the Kramer **RC-63A**) as illustrated in [Figure 3](#):

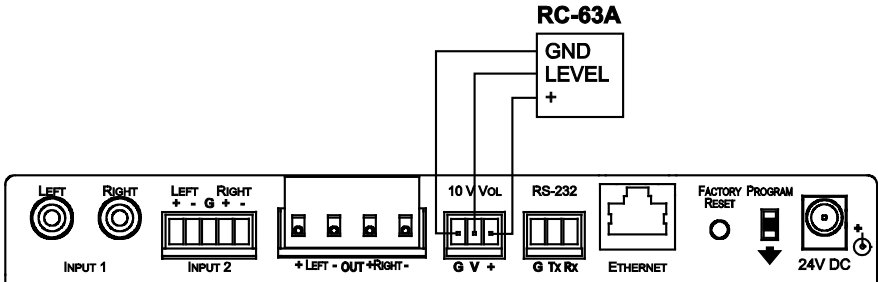

Figure 3: Connecting the 10V VOL Terminal Block Connector

5.2 Connecting a PC

You can connect a PC (or other controller) to the **908** via the RS-232 terminal block connector.

To connect a PC to a **908** unit, connect the RS-232 terminal block connector on the **908** unit to the RS-232 9-pin D-sub port on your PC, see [Figure 4](#):

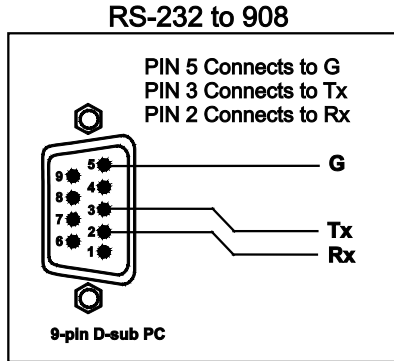

Figure 4: Connecting to a PC

5.3 Connecting the 908 via the Ethernet Port

To connect the **908** via the Ethernet port, do the following:

- When connecting to the Ethernet port on a network hub or network router, use a straight-through cable with RJ-45 connectors
- When connecting to the Ethernet port of a PC, use a crossover cable with RJ-45 connectors

If you are connecting the **908** directly to your computer (not through the network) you may need to reconfigure the PC network settings.

To reconfigure the PC network settings:

1. Navigate to *Start > Settings > Network Connections*.
2. Click on the appropriate *Local Area Connection*.
3. Right-click the *Local Area Connection* and click *Properties*.
The Local Area Properties Window appears:

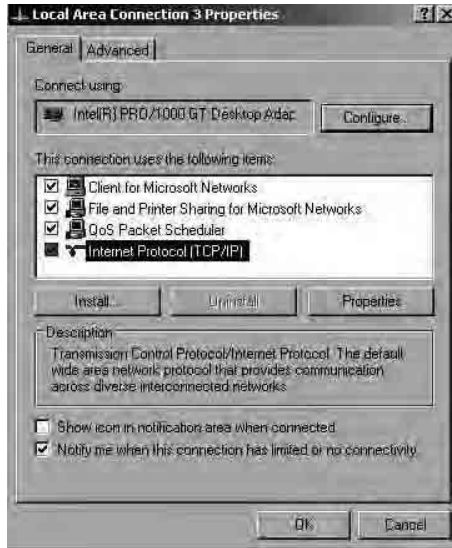

Figure 5: Local Area Properties Window

4. Select *Internet Protocol (TCP/IP)* and click *Properties*. The Internet Protocol (TCP/IP) Properties Window appears:

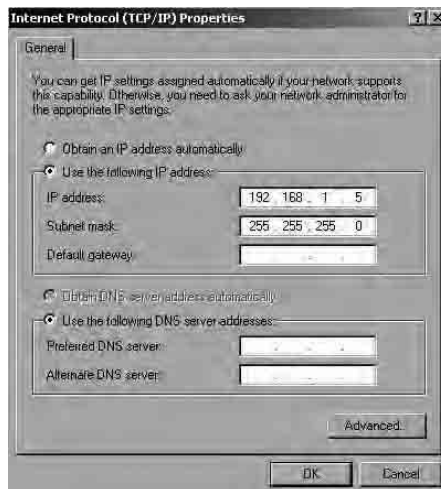

Figure 6: Internet Protocol (TCP/IP) Properties Window

5. Click *Use the following IP address* and enter the IP address and Subnet mask shown above. Click *OK* and *OK* to close both windows and save the settings.

6 Operating the 908

You can operate your **908** using:

- The front panel buttons (see section [6.1](#))
- PC, touch screen system, or other serial controller via RS-232 serial commands (see section [6.2](#))
- The Ethernet via the embedded Web server (see section [6.3](#))
- The included RC-IR3 Infrared Remote Controller (see section [6.4](#))

6.1 Using the Front Panel Buttons

The front panel buttons let you:

- Select an input, by pressing the INPUT 1 or the INPUT 2 button
- Adjust the sound
- Mute the sound by pressing the MUTE button

To adjust the sound of the output signal:

1. Press the sound component that you want to adjust (LOUD, BASS, MID, TREBLE, BAL or VOLUME). The button illuminates.
2. Turn the adjustment knob to adjust the setting.

6.2 Using Serial Commands

To operate your device using serial commands, you need to install Kramer's control software¹.

For an explanation of all control commands, see section [10](#).

6.3 Using the Embedded Web Server

You can remotely operate the **908** using a Web browser via the Ethernet connection (see section [5.3](#)). To be able to do so, you must use a supported Web browser; Microsoft (V6.0 and higher), Chrome or Firefox (V3.0 and higher).

To check that Java is installed correctly and running, browse to:

<http://www.java.com/en/download/help/testvm.xml>

This page runs a test and displays a Java success (see [Figure 7](#)) or failure message.

¹ Download control software from our Web site at <http://www.kramerelectronics.com>



Figure 7: Java Test Page Success Message

If you do not see the success message, follow the instructions on the page to:

- Load and enable Java
- Enable Javascript in your browser

Make sure that your PC is connected via the Ethernet connection to the **908** (see section [5.3](#)) and do the following:

1. Open your Internet browser.
2. Enter the unit's IP number¹ or name in the Address bar of your browser. If you are using DHCP, you must enter the name.



Figure 8: Entering the IP Number in the Address Bar

The following window appears:

¹ The default IP number is 192 168 1 39, and may be changed by the system integrator



Figure 9: Loading the Embedded Web Server

3. Check that Java and JavaScript is enabled in your browser.
The following window appears:



Figure 10: First Time Security Warning

4. Click Run.
The **908** Control Window opens (see [Figure 11](#)):

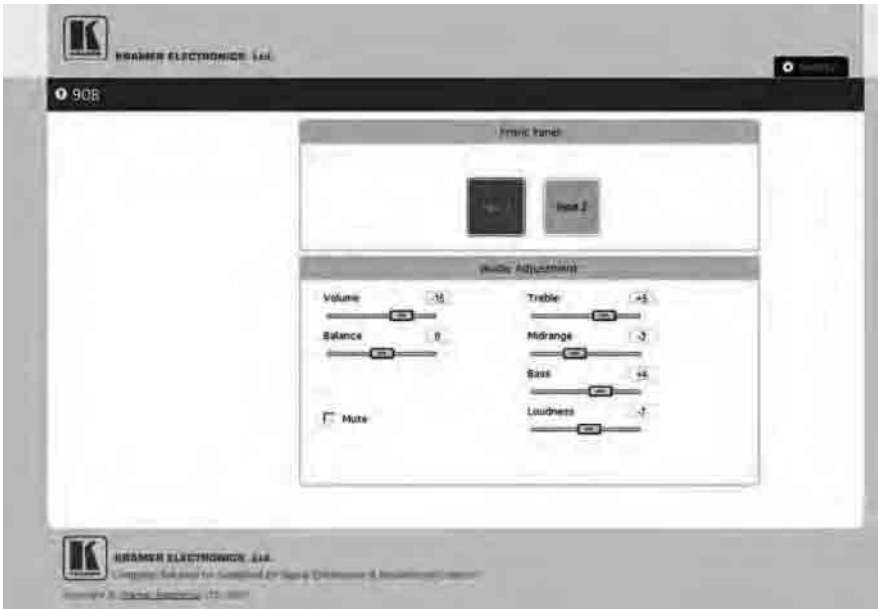

Figure 11: The 908 Control Window

5. To choose the desired input, click on *Input 1* or *Input 2* (see [Figure 12](#)). Each input has its own set of audio adjustments.
6. To adjust each function, click and hold each slider and drag to the right to increase or to the left to decrease the shown value.
7. To mute the output, check the Mute box.

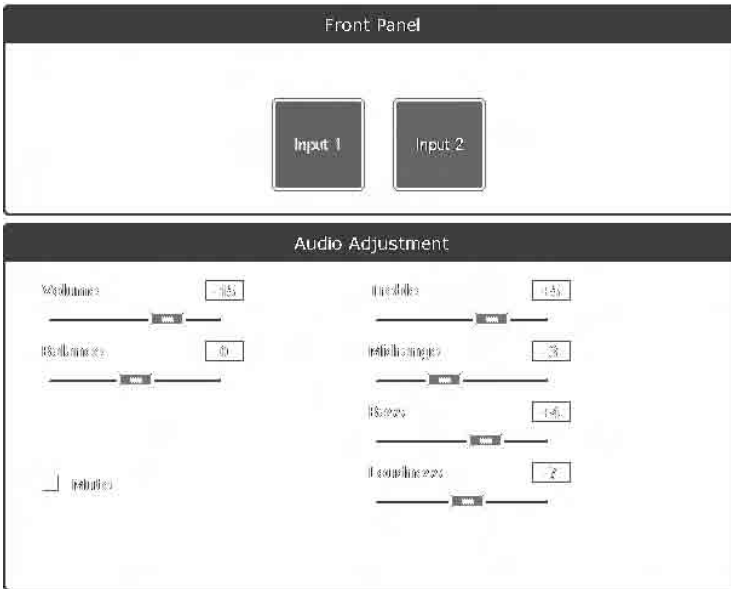

Figure 12: Control Settings

8. To change the Ethernet settings, click the *Settings* tab at the top of the Control Window. The Ethernet settings display (see Figure 13):

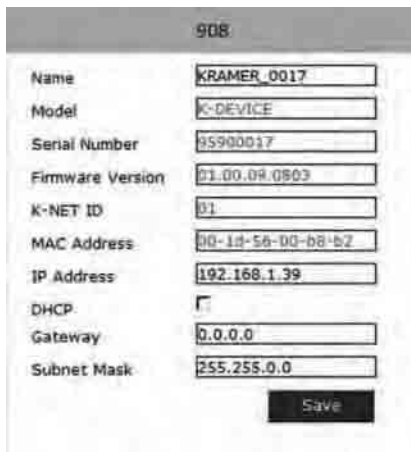

Figure 13: Ethernet Settings

9. Make any necessary changes and click *Save* to save the settings.
10. To return to the Control Window, click *908* under the Kramer logo.

6.4 Using the RC-IR3 Infrared Remote Controller

You can use the **RC-IR3** remote controller to make some¹ of the adjustments that are made using the front panel buttons:

- To choose an input, press button 1 or 2
- To toggle muting, press the OFF button
- To increase the volume, press + (▶)
- To decrease the volume, press – (◀)

7 Updating the 908 Firmware

The **908** functions by means of a device microcontroller that runs firmware located in FLASH memory.

If required, you can download² and upgrade to the latest version of firmware³.

8 Default Communication Parameters

Table 2 lists the communication parameters as used in Kramer Electronics products.

Table 2: Default Communication Parameters

RS-232	
Protocol 3000 (Default)	
Baud Rate:	115,200
Data Bits:	8
Stop Bits:	1
Parity:	None
Command Format:	ASCII
Ethernet Factory Default Values	
IP Address: 192.168.1.39 Mask: 255.255.255.0 Gateway: 192.168.1.1	Power cycle the unit while pressing the Factory Reset button, located on the rear panel of the unit.
TCP Port #: 5000	
UDP Port #: 50000	

¹ Loudness, bass, mid, treble and balance adjustments are not adjustable using the IR remote

² From the Kramer Web site www.kramerelectronics.com

³ The firmware is installed using the P3K software that is also available from the Kramer Web site

9 Technical Specifications

908 technical specifications are shown in Table 3:

Table 3: 908 Technical Specifications¹

INPUTS:	1 unbalanced stereo audio input on RCA connectors 1 balanced stereo audio input on a 5-pin terminal block connector 1 USB connector
OUTPUTS:	1 speaker stereo audio output on a 4-pin terminal block connector
INPUT SENSITIVITY:	Unbalanced: 360mVpp; balanced: 220mVpp
MAX. VOLTAGE GAIN:	Unbalanced: 35dB; balanced: 40.5dB
OUTPUT POWER:	40W per channel into 8Ω
BANDWIDTH (-3dB):	22kHz
CROSSTALK:	<-57dB @20kHz
CONTROLS:	Level: <-30dB to 35.5dB; balance: -30dB to 0dB; loudness: -14dB to 0dB @ 1kHz; bass: -15dB to 12dB @ 100Hz; mid: -15dB to 11dB @ 1kHz; treble: -14dB to 13dB @ 10kHz; input selector buttons, mute button, loudness, bass, mid, treble, balance, volume buttons, IR, RS-232, K-NET, Ethernet, 10V volume control
COUPLING:	Input: AC, output: DC
AUDIO THD + NOISE:	0.15%
AUDIO 2nd HARMONIC:	0.06%
SIGNAL/NOISE RATIO:	63dB, 80dB @ 10% distortion
AMPLIFIER TYPE:	Class D
POWER SOURCE:	24V DC, 2A
DIMENSIONS	18.8cm x 11.4cm x 2.4cm (7.4" x 4.5" x 0.94") W, D, H
WEIGHT:	0.6kg (1.32lbs)
ACCESSORIES:	Power supply, RC-IR3 remote controller
OPTIONS:	RK-T2B 19" rack adapter

¹ Specifications are subject to change without notice

10 908 Commands in Protocol 3000

This RS-232/RS-485 communication protocol lets you control the machine from any standard terminal software (for example, Windows® HyperTerminal Application) and uses a data rate of 115200 baud, with no parity, 8 data bits, and 1 stop bit.

This section describes all commands sent to the **908**. For an explanation of the syntax and use of Protocol 3000, see section [10.10](#).

10.1 Operating Commands

Following are the specific commands that the room controller (RC device) sends to the **908** to operate the external devices.

10.2 Help Commands

Command	Syntax	Response
Protocol handshaking	# <code>CR</code>	~OK <code>CRLF</code>

10.3 Device Initiated Messages

Command	Syntax
Start message	Kramer Electronics LTD. , <code>Device Model</code> Version <code>Software Version</code>

Switcher actions:

Audio channel has switched (breakaway mode)	AUD <code>IN>OUT</code>
---	----------------------------

10.4 Result and Error Codes

	Syntax
Command ran successfully, no error.	<code>COMMAND</code> <code>PARAMETERS</code> OK

Protocol Errors:

Syntax error	ERR001
Command not available for this device	ERR002
Parameter is out of range	ERR003
Unauthorized access (command run without the matching login).	ERR004

10.5 Basic Routing Commands

Command	Syntax	Response
Switch audio only	AUD <u>IN</u> > <u>OUT</u> , <u>IN</u> > <u>OUT</u> , ... Short form: A <u>IN</u> > <u>OUT</u> , <u>IN</u> > <u>OUT</u> , ...	AUD <u>IN</u> > <u>OUT</u> , <u>IN</u> > <u>OUT</u> , ... <u>RESULT</u>
Switch audio only	AUD <u>IN</u> > <u>OUT</u> , <u>IN</u> > <u>OUT</u> , ... Short form: A <u>IN</u> > <u>OUT</u> , <u>IN</u> > <u>OUT</u> , ...	AUD <u>IN</u> > <u>OUT</u> , <u>IN</u> > <u>OUT</u> , ... <u>RESULT</u>
Read audio connection	AUD? <u>OUT</u> Short form: A? <u>OUT</u> AUD? *	AUD <u>IN</u> > <u>OUT</u> AUD <u>IN</u> >1, <u>IN</u> >2, ...

Parameter Description:

IN = Input number or '0' to disconnect output.

'>' = Connection character between in and out parameters.

OUT = Output number or "*" for all outputs.

10.6 Audio Parameters Commands

Command	Syntax	Response
Set simple audio volume	VOLUME <u>VOLUME</u> Short form: VOL <u>VOLUME</u>	VOLUME <u>VOLUME</u> <u>RESULT</u>
Increase/decrease simple audio volume	VOLUME <u>+/-</u> Short form: VOL <u>+/-</u>	VOLUME <u>+/-</u> <u>RESULT</u>
Read simple audio level	VOLUME? Short form: VOL?	VOLUME <u>VOLUME</u>
Set audio level in specific amplifier stage.	AUD-LVL <u>STAGE</u> , <u>CHANNEL</u> , <u>VOLUME</u> Short form: ADL <u>STAGE</u> , <u>CHANNEL</u> , <u>VOLUME</u>	AUD-LVL <u>STAGE</u> , <u>CHANNEL</u> , <u>VOLUME</u> <u>RESULT</u>
Read audio volume level	AUD-LVL? <u>STAGE</u> , <u>CHANNEL</u> Short form: ADL? <u>STAGE</u>	AUD-LVL <u>STAGE</u> , <u>CHANNEL</u> , <u>VOLUME</u>

Advanced commands for controlling each stage of audio amplification:

Set audio bass level	BASS <u>CHANNEL</u> , <u>BASS</u> Short form: ADB <u>CHANNEL</u> , <u>BASS</u>	BASS <u>CHANNEL</u> , <u>BASS</u> <u>RESULT</u>
Read audio bass level	BASS? <u>CHANNEL</u> Short form: ADB? <u>CHANNEL</u>	BASS <u>CHANNEL</u> , <u>BASS</u>
Set audio treble level	TREBLE <u>CHANNEL</u> , <u>TREBLE</u> Short form: ADT <u>CHANNEL</u> , <u>TREBLE</u>	TREBLE <u>CHANNEL</u> , <u>TREBLE</u> <u>RESULT</u>
Read audio treble	TREBLE? <u>CHANNEL</u> Short form: ADT? <u>CHANNEL</u>	TREBLE <u>CHANNEL</u> , <u>TREBLE</u>
Set audio midrange	MIDRANGE <u>CHANNEL</u> , <u>MID_RANGE</u> Short form: ADM <u>CHANNEL</u> , <u>MID_RANGE</u>	MIDRANGE <u>CHANNEL</u> , <u>MID_RANGE</u> <u>RESULT</u>
Read audio midrange	MIDRANGE? <u>CHANNEL</u> Short form: ADM? <u>CHANNEL</u>	MIDRANGE <u>CHANNEL</u> , <u>MID_RANGE</u>
Set audio loudness	LOUDNESS <u>CHANNEL</u> , <u>LOUDNESS</u> Short form: ADS <u>CHANNEL</u> , <u>LOUDNESS</u>	LOUDNESS <u>CHANNEL</u> , <u>LOUDNESS</u> <u>RESULT</u>
Read audio loudness	LOUDNESS? <u>CHANNEL</u> Short form: ADS? <u>CHANNEL</u>	LOUDNESS <u>CHANNEL</u> , <u>LOUDNESS</u>
Mute audio	MUTE <u>MUTE-MODE</u>	MUTE <u>MUTE-MODE</u> <u>RESULT</u>

Command	Syntax	Response
Read audio mute state	MUTE?	MUTE <u>MUTE-MODE</u>
Set stereo mode	STEREO <u>STEREO-MODE</u>	STEREO <u>STEREO-MODE</u> <u>RESULT</u>
Read stereo mode	STEREO?	STEREO <u>STEREO-MODE</u>
Set balance mode	BALANCE <u>OUT-CHANNEL</u> <u>BALANCE-LEVEL</u>	BALANCE <u>OUT-CHANNEL</u> <u>BALANCE-LEVEL</u> <u>RESULT</u>
Read balance mode	BALANCE? <u>OUT-CHANNEL</u>	BALANCE <u>OUT-CHANNEL</u> <u>BALANCE-LEVEL</u>

Parameter Description:
STAGE = 'IN', 'OUT'
 or
 Numeric value of present audio processing stage. For example: '0' for input level, '1' for pre-amplifier, '2' for amplifier (OUT) etc.
CHANNEL = Input or Output #
VOLUME / BASS / TREBLE / MID_RANGE = Audio parameter in Kramer units, minus sign precedes negative values.
 ++ increase current value,
 -- decrease current value.

10.7 Identification Commands

Command	Syntax	Response
Protocol handshaking	# <u>CR</u>	~OK <u>CRLF</u>
Read device model	MODEL?	MODEL <u>MACHINE_MODEL</u>
Read device serial number	SN?	SN <u>SERIAL_NUMBER</u>
Read device firmware version	VERSION?	VERSION <u>MAJOR</u> <u>MINOR</u> <u>BUILD</u> <u>REVISION</u>
Set machine name	NAME <u>MACHINE_NAME</u>	NAME <u>MACHINE_NAME</u> <u>RESULT</u>
Read machine name	NAME?	NAME <u>MACHINE_NAME</u>
Reset machine name to factory default*	NAME-RST	NAME-RST <u>MACHINE_FACTORY_NAME</u> <u>RESULT</u>

***Note:** The machine name is not the same as the model name. The machine name is used to identify a specific machine or a network in use (with DNS feature on).

MACHINE_NAME = Up to 14 alphanumeric chars.

* **Machine factory name** = Model name + last 4 digits from serial number.

Set machine ID number	<u>MACH-NUM</u> <u>MACHINE_NUMBER</u>	<u>MACH-NUM</u> <u>OLD_MACHINE_NUMBER</u> <u>NEW_MACHINE_NUMBER</u> <u>RESULT</u>
-----------------------	--	--

* A response is sent after the machine number was changed. The response with the header is:

NEW_MACHINE_NUMBER @MACH-NUM OLD_MACHINE_NUMBER NEW_MACHINE_NUMBER OK

10.8 Network Setting Commands

Command	Syntax	Response
Set IP address	NET-IP <u>IP_ADDRESS</u> Short form: NTIP	NET-IP <u>IP_ADDRESS</u> <u>RESULT</u>
Read IP address	NET-IP? Short form: NTIP?	NET-IP <u>IP_ADDRESS</u>
Read MAC address	NET-MAC? Short form: NTMC	NET-MAC <u>MAC_ADDRESS</u>
Set subnet mask	NET-MASK <u>SUBNET_MASK</u> Short form: NTMSK	NET-MASK <u>SUBNET_MASK</u> <u>RESULT</u>
Read subnet mask	NET-MASK? Short form: NTMSK?	NET-MASK <u>SUBNET_MASK</u>
Set gateway address	NET-GATE <u>GATEWAY_ADDRESS</u> Short form: NTGT	NET-GATE <u>GATEWAY_ADDRESS</u> <u>RESULT</u>
Read subnet mask	NET-GATE? Short form: NTGT?	NET-GATE <u>GATEWAY_ADDRESS</u>
Set DHCP mode	NET-DHCP <u>DHCP_MODE</u> Short form: NTDH	NET-DHCP <u>DHCP_MODE</u> <u>RESULT</u>
Read subnet mask	NET-DHCP? Short form: NTDH?	NET-DHCP <u>DHCP_MODE</u>

DHCP_MODE =

'0' – Don't use DHCP (Use IP set by factory or IP set command).

'1' – Try to use DHCP, if unavailable use IP as above.

Change protocol E hernet port	ETH-PORT <u>PROTOCOL</u> <u>PORT</u> Short form: ETHP	ETH-PORT <u>PROTOCOL</u> <u>PORT</u> <u>RESULT</u>
Read protocol E hernet port	ETH-PORT? <u>PROTOCOL</u> Short form: ETHP?	ETH-PORT <u>PROTOCOL</u> <u>PORT</u>

PROTOCOL = TCP/UDP (transport layer protocol)

PORT = Ethernet port that accepts Protocol 3000 commands

1-65535 = User defined port

0 - Reset port to factory default (50000 for UDP, 5000 for TCP)

10.9 Machine Information Commands

Command	Syntax	Response
Set device time and date	TIME <u>DATE_TIME</u>	TIME <u>DATE_TIME</u> <u>RESULT</u>
Read device time and date	TIME?	TIME? <u>DATE_TIME</u>
Read in/out count	INFO-IO?	INFO-IO: IN <u>INPUTS_COUNT</u> , OUT <u>OUTPUTS_COUNT</u>
Read max preset count	INFO-PRST?	INFO-PRST: VID <u>PRESET_VIDEO_COUNT</u> , AUD <u>PRESET_AUDIO_COUNT</u>
Execute firmware upgrade*	UPGRADE	UPGRADE OK

Firmware usually uploads to a device via a command like LDFW. The device may need to be reset to complete the process.

Command	Syntax	Response
Reset to factory default configuration	FACTORY	FACTORY RESULT
Set model name	FCT-MODEL FACTORY_PASSWORD MODEL_NAME	FCT-MODEL MAC_ADDRESS RESULT
Set MAC address	FCT-MAC FACTORY_PASSWORD MAC_ADDRESS	FCT-MAC MAC_ADDRESS RESULT
Set SN #	FCT-SN FACTORY_PASSWORD SN#	FCT-SN SN# RESULT

*If implemented by hard coding, protocol command is unnecessary

* Machine factory settings commands are not for public knowledge. Reference is only for internal implementation

10.10 Protocol 3000 Syntax

Protocol 3000 is used to control the **908** via an RS-232 connection using a PC, touch screen, other serial controller or RC type controller.

10.10.1 Host Message Format

Start	Address (optional)	Body	Delimiter
#	<i>Destination_id@</i>	Message	CR

10.10.2 Simple Command

Command string with only one command without addressing:

Start	Body	Delimiter
#	Command SP <i>Parameter_1,Parameter_2,...</i>	CR

10.10.3 Command String

Formal syntax with commands concatenation and addressing:

Start	Address	Body	Delimiter
#	<i>Destination_id@</i>	Command_1 <i>Parameter1_1,Parameter1_2,...</i> Command_2 <i>Parameter2_1,Parameter2_2,...</i> Command_3 <i>Parameter3_1,Parameter3_2,...</i>	CR

10.10.4 Device Message Format

Start	Address (optional)	Body	delimiter
~	<i>Sender_id@</i>	Message	CR LF

10.10.5 Device Long Response

Echoing command:

Start	Address (optional)	Body	Delimiter
~	<i>Sender_id@</i>	Command SP [<i>Param1 ,Param2 ...</i>] result	CR LF

CR = Carriage return (ASCII 13 = 0x0D)

LF = Line feed (ASCII 10 = 0x0A)

SP = Space (ASCII 32 = 0x20)

10.10.6 Command Terms

Command

A sequence of ASCII letters ('A'-'Z', 'a'-'z' and '-').

Command and parameters must be separated by at least one space.

Parameters

A sequence of alphanumeric ASCII characters ('0'-'9', 'A'-'Z', 'a'-'z' and some special characters for specific commands). Parameters are separated by commas.

Message string

Every command entered as part of a message string begins with a **message starting character** and ends with a **message closing character**.

Note: A string can contain more than one command. Commands are separated by a pipe ('|') character.

Message starting character

#' – For host command/query

~' – For machine response

Device address (Optional, for K-NET)

K-NET Device ID followed by '@'

Query sign

'?' follows some commands to define a query request.

All outputs sign

'*' defines all outputs.

Message closing character

CR – For host messages; carriage return (ASCII 13)

CRLF – For machine messages; carriage return (ASCII 13) + line-feed (ASCII 10)

Command chain separator character

When a message string contains more than one command, a pipe ('|') character separates each command.

Spaces between parameters or command terms are ignored.

10.10.7 Entering Commands

You can directly enter all commands using a terminal with ASCII communications software, such as HyperTerminal, Hercules, etc. Connect the terminal to the serial, Ethernet, or USB port on the Kramer device. To enter CR, press the Enter key.

(LF is also sent but is ignored by command parser).

For commands sent from some non-Kramer controllers like Crestron, some characters require special coding (such as, /X##). Refer to the controller manual.

10.10.8 Command Forms

Some commands have short name syntax in addition to long name syntax to allow faster typing. The response is always in long syntax.

10.10.9 Command Chaining

Multiple commands can be chained in the same string. Each command is delimited by a pipe character ('|'). When chaining commands, enter the **message starting character** and the **message closing character** only once, at the beginning of the string and at the end.

Commands in the string do not execute until the closing character is entered.

A separate response is sent for every command in the chain.

10.10.10 Maximum String Length

64 characters.

LIMITED WARRANTY

Kramer Electronics (hereafter *Kramer*) warrants this product free from defects in material and workmanship under the following terms

HOW LONG IS THE WARRANTY

Labor and parts are warranted for seven years from the date of the first customer purchase

WHO IS PROTECTED?

Only the first purchase customer may enforce this warranty

WHAT IS COVERED AND WHAT IS NOT COVERED

Except as below, this warranty covers all defects in material or workmanship in this product. The following are not covered by the warranty:

- 1 Any product which is not distributed by Kramer, or which is not purchased from an authorized Kramer dealer. If you are uncertain as to whether a dealer is authorized, please contact Kramer at one of the agents listed in the Web site www.kramerelectronics.com
- 2 Any product, on which the serial number has been defaced, modified or removed, or on which the WARRANTY VOID IF TAMPERED sticker has been torn, reattached, removed or otherwise interfered with
- 3 Damage, deterioration or malfunction resulting from:
 - i) Accident, misuse, abuse, neglect, fire, water, lightning or other acts of nature
 - ii) Product modification, or failure to follow instructions supplied with the product
 - iii) Repair or attempted repair by anyone not authorized by Kramer
 - iv) Any shipment of the product (claims must be presented to the carrier)
 - v) Removal or installation of the product
 - vi) Any other cause, which does not relate to a product defect
 - vii) Cartons, equipment enclosures, cables or accessories used in conjunction with the product

WHAT WE WILL PAY FOR AND WHAT WE WILL NOT PAY FOR

We will pay labor and material expenses for covered items. We will not pay for the following:

- 1 Removal or installations charges
- 2 Costs of initial technical adjustments (set-up), including adjustment of user controls or programming. These costs are the responsibility of the Kramer dealer from whom the product was purchased
- 3 Shipping charges

HOW YOU CAN GET WARRANTY SERVICE

- 1 To obtain service on your product, you must take or ship it prepaid to any authorized Kramer service center
- 2 Whenever warranty service is required, the original dated invoice (or a copy) must be presented as proof of warranty coverage, and should be included in any shipment of the product. Please also include in any mailing a contact name, company, address, and a description of the problem(s)
- 3 For the name of the nearest Kramer authorized service center, consult your authorized dealer

LIMITATION OF IMPLIED WARRANTIES

All implied warranties, including warranties of merchantability and fitness for a particular purpose, are limited in duration to the length of this warranty

EXCLUSION OF DAMAGES

The liability of Kramer for any effective products is limited to the repair or replacement of the product at our option. Kramer shall not be liable for:

- 1 Damage to other property caused by defects in this product, damages based upon inconvenience, loss of use of the product, loss of time, commercial loss; or
- 2 Any other damages, whether incidental, consequential or otherwise. Some countries may not allow limitations on how long an implied warranty lasts and/or do not allow the exclusion or limitation of incidental or consequential damages, so the above limitations and exclusions may not apply to you

This warranty gives you specific legal rights, and you may also have other rights, which vary from place to place

NOTE: All products returned to Kramer for service must have prior approval. This may be obtained from your dealer.

This equipment has been tested to determine compliance with the requirements of:

- EN-50081: "Electromagnetic compatibility (EMC);
generic emission standard
Part 1: Residential, commercial and light industry"
- EN-50082: "Electromagnetic compatibility (EMC) generic immunity standard
Part 1: Residential, commercial and light industry environment"
- CFR-47: FCC* Rules and Regulations:
Part 15: "Radio frequency devices
Subpart B Unintentional radiators"

CAUTION!

- Servicing the machines can only be done by an authorized Kramer technician. Any user who makes changes or modifications to the unit without the expressed approval of the manufacturer will void user authority to operate the equipment.
- Use the supplied DC power supply to feed power to the machine.
- Please use recommended interconnection cables to connect the machine to other components.

* FCC and CE approved using STP cable (for twisted pair products)



For the latest information on our products and a list of Kramer distributors, visit our Web site: www.kramerelectronics.com where updates to this user manual may be found. We welcome your questions, comments and feedback.



Caution

Safety Warning:

Disconnect the unit from the power supply before opening/servicing.



Kramer Electronics, Ltd.

Web site: www.kramerelectronics.com

E-mail: info@kramerel.com

P/N: 2900-000537 REV 3