

# HUTTRA

GB



Design and Quality  
IKEA of Sweden





**Table of contents**

Safety information	4	Cleaning and maintenance	12
Product description	8	What to do if ...	13
First use	8	Technical data	14
Daily use	9	Environmental concerns	15
Helpful hints and tips	10	IKEA GUARANTEE	15

**Safety Information**

**WARNING:** To reduce the risk of fire, electric shock, or injury when using your refrigerator, follow these basic precautions:

- to avoid a hazard due to instability, positioning or fixing of the appliance must be done in accordance with the manufacturer instructions.
- This appliance is intended to be used in household and similar applications such as
  - staff kitchen areas in shops, offices and other working environments;
  - farm houses and by clients in hotels, motels and other residential type environments;
  - bed and breakfast type environments;
  - catering and similar non-retail applications.
- This appliance does not contain CFCs. The refrigerant circuit contains R600a (HC).
- Appliances with Isobutane (R600a): isobutane is a natural gas without environmental impact, but is

flammable.

Therefore, make sure the refrigerant circuit pipes are not damaged.

Keep special attention in case of damaged pipes emptying the refrigerant circuit.

- C-Pentane is used as blowing agent in the insulation foam and it is a flammable gas. Pay special attention during disposal operations.
- Do not damage the appliance refrigerant circuit pipes.
- Do not store explosive substances such as aerosol cans with a flammable propellant in this appliance.
- Keep the appliance ventilation openings clear of obstruction.
- Do not attempt to speed up defrosting process and perform defrosting in any other way than described in the User Manual.
- Do not use or place electrical devices inside the appliance compartments if they are not of the type

- expressly authorised by the Manufacturer.
- This appliance can be used by children aged from 8 years and above and persons with reduced physical, sensory or mental capabilities or lack of experience and knowledge if they have been given supervision or instruction concerning use of the appliance in a safe way and understand the hazards involved. Cleaning and user maintenance shall not be made by children without supervision.
  - To avoid the risk of children becoming trapped and suffocating, do not allow them to play or hide inside the appliance.
  - During installation, make sure the appliance does not damage the power cable.
  - Do not pull the appliance power cable.
  - Do not use single/multi adapters or extension cords.
  - Plug the appliance into a grounded (earthed) socket: the appliance must be earthed.
  - The appliance must be disconnected from its power source during service and when replacing parts
- It must be possible to disconnect the appliance from the power supply by unplugging it if plug is accessible, or by means of an accessible multi-pole switch installed upstream of the socket in conformity with national safety standards.
  - The appliance must be handled and installed by two or more persons.
  - Installation and maintenance including replacement of the supply cord must be carried out by the manufacturer or a qualified technician, in compliance with the manufacturer's instructions and the local safety regulations in force. In order to avoid a hazard do not repair or replace any part of the appliance including the supply cord, unless specifically stated in the user manual.

**Before first use**

To ensure best use of your appliance, carefully read this User Manual which contains a description of the product and useful advice.

Keep these instructions for future reference.

1. After unpacking the appliance, make sure it is not damaged and that the door closes properly.  
Any functional fault must be reported to IKEA After Sales Service as soon as possible.
2. Wait at least two hours before switching the appliance on, to ensure that the refrigerant circuit is fully efficient.
3. Clean the inside of the appliance before using it.

**Precautions and general recommendations**

**Installation and connection**

- Be careful not to damage the floors (e.g. parquet) when moving the appliance.
- Make sure the appliance is not near a heat source.
- Install and level the appliance on a floor strong enough to take its weight and in a place suitable for its size and use.
- The appliance is arranged for operation in places where the temperature comes within the following ranges, according to the climatic class given on the rating plate. The appliance may not work properly if it is left for a long time at a temperature outside the specified range.

Climatic Class	Amb. T. (°C)
SN	From 10 to 32
N	From 16 to 32
ST	From 16 to 38
T	From 16 to 43

- Make sure the voltage specified on the rating plate corresponds to that of your home.

**Safety**

- Do not store or use petrol, flammable liquids or gas in the vicinity of this or other electrical appliances. The fumes can cause fires or explosions.
- Do not swallow the contents (non-toxic) of the ice packs (in some models).
- Do not eat ice cubes or ice lollies immediately after taking them out of the freezer since they may cause cold burns.

**Use**

- Before carrying out any maintenance or cleaning operation, unplug the appliance or disconnect it from the power supply.
- Use the refrigerator compartment only for storing fresh food and the freezer compartment only for storing frozen food, freezing fresh food and making ice cubes.
- Do not store glass containers with liquids in the freezer compartment since they may break.
- Avoid storing unwrapped food in direct contact with internal surfaces of the refrigerator or freezer compartments.
- The bulb used inside the appliance is specifically designed for domestic appliances and is not suitable for general room lighting within the home (EC Regulation 244/2009).

The Manufacturer declines any liability for injury to persons or animals or damage to property if the above advice and precautions are not respected.

**Energy-saving tips**

- Install the appliance in a dry, well ventilated room far away from any heat source (e.g. radiator, cooker, etc.) and in a place not exposed directly to the sun. If required, use an insulating plate.
- To guarantee adequate ventilation follow installation instructions.
- Insufficient ventilation on back of the

product increases energy consumption and decreases cooling efficiency.

- The internal temperatures of the appliance may be affected by the ambient temperature, frequency of door opening, as well as location of the appliance. Temperature setting should take into consideration these factors.
- Allow warm food and drinks to cool down before placing in the appliance.
- Do not obstruct the fan (if available) with food items.
- After placing the food check if the door of compartments closes properly, especially the freezer door.
- Reduce to a minimum door opening.
- When thawing frozen food, place them in the refrigerator. The low temperature of the frozen products cools the food in the refrigerator.
- Positioning of the shelves in the refrigerator has no impact on the efficient usage of energy. Food should be placed on the shelves in such way to ensure proper air circulation (food should not touch each other and distance between food and rear wall should be kept).
- You can increase storage capacity of frozen food by removing baskets maintaining an equivalent energy consumption.
- Damaged gasket must be replaced as soon as possible.

**Product description**

Carefully read the operating instructions before using the appliance.

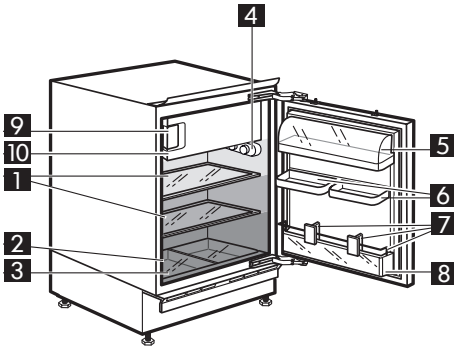

**Refrigerator compartment**  
(for storage of fresh food and beverages)

- 1 Glass shelves
- 2 Rating plate (at the side of crisper drawer)
- 3 Crisper drawer
- 4 Thermostat control knob/light
- 5 Dairy lid / Dairy compartment
- 6 Adjustable door balcony
- 7 Metal wire and bottle divider
- 8 Bottle balcony

**Freezer compartment**  
(marked with the symbol for storing fresh food, frozen food and making ice cubes)

- 9 Ice cube tray
- 10 Low Temperature compartment door

- Least cold zone
- Intermediate temperature zone
- Coldest zone

**Features, technical information and images may vary depending on model**

**Accessories**

Egg tray

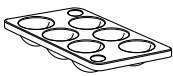

1x

Ice tray

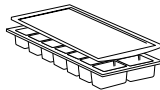

1x

Ice scraper

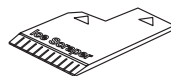

1x

**First Use**

Connect the appliance to the mains power supply.

The ideal temperatures for preserving food have already been set at the factory (3-5/ MED).

**Note:** After switching the appliance on, it will be necessary to wait for 2 to 3 hours before a temperature suitable for a standard appliance load is reached.



**Important!**

This appliance is sold in France. In accordance with regulations valid in this country it must be provided with a special device (see figure) placed in the lower compartment of the fridge to indicate the coldest zone of it.

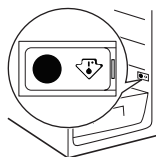
**Daily use****Operation of the refrigerator and freezer compartment**

- Use the thermostat knob to adjust the temperature of the refrigerator compartment (or both compartments, depending on the model), as shown in figure 1. Move the knob to the ● position to switch the whole appliance off.

**Note:** The ambient temperature, frequency of door opening and position of the appliance can affect the temperatures inside the two compartments. These factors must be taken into consideration when setting the thermostat.

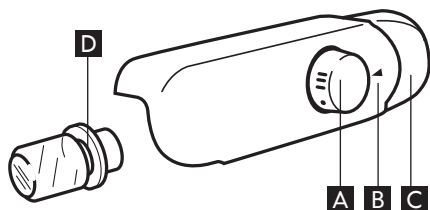

- A** Thermostat control knob
- B** Light button
- C** Thermostat position setting notch
- D** LED light bulb (see instructions near the light bulb)

Thermostat on **1/MIN: Low refrigeration level**

Thermostat on **3-5/MED: Medium refrigeration**

Thermostat on **7/MAX: Maximum refrigeration**

Thermostat on **●: Both refrigeration and illumination are switched off.**

**Refrigerator compartment**

Refrigerator compartment defrosting is completely automatic. Droplets of water on the rear wall inside the refrigerator compartment indicate that the automatic defrost phase is in progress. The defrost water is automatically run into a drain hole and collected in a container, where it evaporates.

**Caution!** The refrigerator accessories must not be placed in a dishwasher

**Movable shelves**

The walls of the refrigerator are equipped with a series of runners so that the safety glass shelves can be positioned as desired. For better use of space, the front halfshelves can lie over the rear ones.

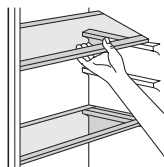
**Freezer compartment**

This appliance is a refrigerator with a **★** star rating freezer compartment. Packed frozen foods can be stored for the period indicated on the packing. Fresh food can also be frozen, ensuring that any contact with already frozen food is avoided. The quantity of fresh food that can be frozen in a 24 hour period is given on the rating plate. Re-freezing of partially defrosted food is not recommended. This food should be consumed within 24 hours. For further information on freezing fresh food, refer to the quick guide.

**Freezing fresh food**

Place the fresh food to be frozen inside the freezer compartment. Avoid direct contact with already frozen food. To freeze the quantity of food shown on the serial tag, remove the top drawer and place the food directly on the rack.

**Making ice cubes**

Fill the ice cube tray up to 2/3 with water and place in the freezer compartment. Do not use sharp or pointed objects to detach the tray.

**Helpful hints and tips****Hints for energy saving**

- Do not open the door frequently or leave it open longer than absolutely necessary.
- If the ambient temperature is high, the temperature regulator is on the higher setting and the appliance is fully loaded, the compressor may run continuously, causing frost or ice on the evaporator. If this happens, turn the temperature regulator toward lower settings to allow automatic defrosting and so a saving in electricity consumption.

**Hints for fresh food refrigeration**

To obtain the best performance:

- Do not store warm food or evaporating liquids in the refrigerator.
- Do cover or wrap the food, particularly if it has a strong flavour.
- Position food so that air can circulate freely around it.

**Hints for refrigeration**

- Meat (all types) : wrap in polythene bags and place on the glass shelf above the vegetable drawer.  
For safety, store in this way only one or two days at the most.
- Cooked foods, cold dishes, etc.: these should be covered and may be placed on any shelf.
- Fruit and vegetables: these should be thoroughly cleaned and placed in the drawer.

- Butter and cheese: these should be placed in special airtight containers or wrapped in aluminium foil or polythene bags to exclude as much air as possible.
- Milk bottles: these should have a cap and should be stored in the bottle rack on the door.
- Bananas, potatoes, onions and garlic: if not packed, must not be kept in the refrigerator.

**Hints for freezing**

To help you make the most of the freezing process, here are some hints:

- The maximum quantity of food which can be frozen in 24 hours is shown on the rating plate.
- The freezing process takes 24 hours. No further food to be frozen should be added during this period.
- Freeze only top quality, fresh and thoroughly cleaned foodstuffs.
- Prepare food in small portions to enable it to be rapidly and completely frozen and to make it possible subsequently to thaw only the quantity required.
- Wrap up the food in aluminium foil or polythene and make sure that the packages are airtight.
- Do not allow fresh, unfrozen food to touch food which is already frozen, thus avoiding a rise in temperature of the latter.

- Lean foods store better and longer than fatty ones; salt reduces the storage life of food.
- Water ices, if consumed immediately after removal from the freezer compartment, can possibly cause the skin to be freeze burnt.
- It is advisable to show the freezing in date on each individual pack to enable you to keep tab of the storage time.

**Hints for storage of frozen food**

To obtain the best performance from this appliance, you should:

- Make sure that the commercially frozen foodstuffs were adequately stored by the retailer.
- Make sure that frozen foodstuffs are transferred from the foodstore to the freezer in the shortest possible time.
- Do not open the door frequently or leave it open longer than absolutely necessary.
- Once defrosted, food deteriorates rapidly and cannot be refrozen.
- Do not exceed the storage period indicated by the food manufacturer.

## Cleaning and Maintenance

Regularly clean the appliance with a cloth and a solution of hot water and neutral detergent specifically formulated for refrigerator interiors. Do not use abrasive cleaners or tools. Use the tool provided to regularly clean the defrost water drain outlet, located on the rear wall of the refrigerator compartment near the crisper draw, in order to ensure defrost water is removed correctly (see Fig. 1).

Before servicing or cleaning the appliance, unplug it from the mains or disconnect the power supply.

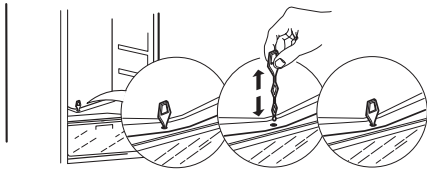

Fig. 1

### Defrosting the freezer compartment

It is perfectly normal for ice to form. The amount of ice which forms and the rate at which it accumulates will depend on ambient temperature and humidity, and on the frequency of door opening.

Set the coldest temperature four hours before removing food from the freezer compartment, so as to extend the storage time of food during defrosting.

To defrost, switch the appliance off and remove the drawers. Place the frozen food in a cool place.

Leave the freezer door open to allow the frost to melt.

To prevent water leaking onto the floor during defrosting, place an absorbent cloth on the bottom of the freezer compartment and wring it out regularly.

Clean the interior of the freezer. Rinse and

dry carefully.

Switch the appliance on again and place food back in the freezer compartment.

### Food storage

Wrap food to protect it from any water, humidity or condensation; this will prevent the spread of any odours in the refrigerator, while also ensuring better storage of frozen food.

Never place warm food in the freezer.

Cooling hot foods before freezing saves energy and prolongs the life of the appliance.

### If the event of prolonged disuse

Disconnect the appliance from the power supply, remove all food, defrost and clean the appliance. Leave the doors open just enough to allow air to circulate inside the compartments.

This will prevent the formation of mould and unpleasant odours.

### In the event of a power cut

Keep the doors of the appliance closed.

This will allow the food to stay cold as long as possible. If food has defrosted even partially, do not re-freeze it. Consume within 24 hours.

**What to do if...**

Problem	Possible causes:	Solutions:
The appliance does not operate	There might be a problem with the electric power supply to the appliance.	Check that: <ul style="list-style-type: none"> <li>• there isn't a power supply failure</li> <li>• the power plug is correctly inserted in the power socket and the two-pole switch, if present, is in the correct position (on)</li> <li>• the electric circuit safety devices installed in the house are fully functional</li> <li>• the power supply cable is not broken</li> </ul>
The inside LED light bulb does not work.	The LED light bulb might need replacing.	Disconnect the appliance from the electric power supply, check the LED light bulb and replace with a new one if necessary (see "Daily use").
The temperature inside the compartments is not cold enough.	There may be several causes (see "Solutions")	Check that: <ul style="list-style-type: none"> <li>• The doors are closed correctly</li> <li>• The appliance is not placed near a heat source.</li> <li>• the temperature set is appropriate.</li> <li>• Air circulation through the ventilation grills at the bottom of the appliance is not obstructed.</li> </ul>
There is water at the bottom of the refrigerator compartment	The defrost water drain is obstructed.	Clean the defrost water drain hole (see "Cleaning and maintenance").

**Note:**

Gurgling, hissing and humming noises from the refrigerating system are normal.

**Remove the LED light bulb**

To remove the LED light bulb turn anticlockwise as shown in figure.

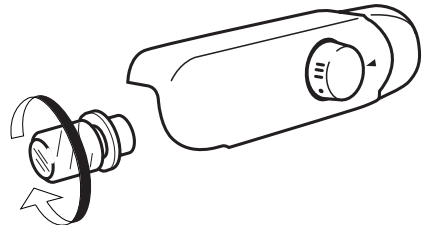

**Before contacting the After-Sales Service:**

Switch the appliance on again to see if the problem has disappeared. If not, switch it off again and repeat the operation after an hour.

If your appliance still does not work properly after carrying out the checks listed in the troubleshooting guide and switching the appliance on again, contact the After-sales service, clearly explaining the problem and specifying:

- the type of fault;
- the model;

- the type and serial number of the appliance (given on the rating plate);
- the Service number (the number after the word SERVICE on the rating plate inside the appliance).

**SERVICE** 0000 000 00000



**Technical data**

Dimensions	HUTTRA
Height (min-max)	819-899
Width	597
Depth	545
<b>Net Volume (l)</b>	
Refrigerator	108
Freezer	18
<b>Defrost system</b>	
Refrigerator	Automatic
Freezer	Manual
<b>Star Rating</b>	4
<b>Rising Time (h)</b>	14
<b>Freezing capacity (kg/24 h)</b>	2
<b>Energy consumption (kwh/24h)</b>	0,386
<b>Noise level (dba)</b>	38
<b>Energy class</b>	A++

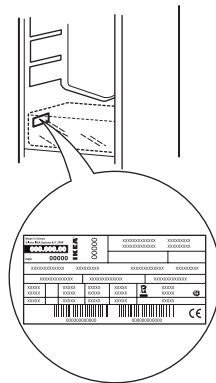

The technical information is situated in the rating plate on the internal side of the appliance and in the energy label

## Environmental concerns

### 1. Packing

The packing material is 100% recyclable and bears the recycling symbol. For disposal, comply with the local regulations. Keep the packing materials (plastic bags, polystyrene parts, etc.) out of the reach of children, as they are a potential source of danger.

### 2. Scrapping/Disposal

The appliance is manufactured using recyclable material.

This appliance is marked in compliance with European Directive 2002/96/EC on Waste Electrical and Electronic Equipment (WEEE). By ensuring the correct disposal of this appliance, you can help prevent potentially negative consequences for the environment and the health of persons.



The symbol  on the appliance, or on the accompanying documents, indicates that this appliance should not be treated as domestic waste but must be taken to a special collection centre for the recycling of electrical and electronic equipment. When scrapping the appliance, make it unusable by cutting off the power cable and removing the doors and shelves so that children cannot easily climb inside and

become trapped.

Scrap the appliance in compliance with local regulations on waste disposal, taking it to a special collection centre; do not leave the appliance unattended even for a few days, since it is a potential source of danger for children. For further information on the treatment, recovery and recycling of this product, contact your competent local office, the household waste collection service or the shop where you purchased the appliance.

### Declaration of conformity

- This appliance has been designed for preserving food and is manufactured in compliance with Regulation (CE) No. 1935/2004.



- This appliance has been designed, manufactured and marketed in compliance with:
  - safety objectives of the “Low Voltage” Directive 2006/95/CE (which replaces 73/23/CEE and subsequent amendments);
  - the protection requirements of Directive “EMC” 2004/108/EC.

## IKEA GUARANTEE

### How long is the IKEA guarantee valid?

This guarantee is valid for five (5) years from the original date of purchase of your appliance at IKEA, unless the appliance is named LAGAN in which case two (2) years of guarantee apply. The original sales receipt, is required as proof of purchase. If service work is carried out under guarantee, this will not extend the guarantee period for the appliance.

### Which appliances are not covered by the IKEA five (5) years guarantee?

The range of appliances named LAGAN and all appliances purchased in IKEA before 1st of August 2007.

### Who will execute the service?

IKEA service provider will provide the service through its own service operations or authorized service partner network.

**What does this guarantee cover?**

The guarantee covers faults of the appliance, which have been caused by faulty construction or material faults from the date of purchase from IKEA. This guarantee applies to domestic use only. The exceptions are specified under the headline "What is not covered under this guarantee?" Within the guarantee period, the costs to remedy the fault e.g. repairs, parts, labour and travel will be covered, provided that the appliance is accessible for repair without special expenditure. On these conditions the EU guidelines (Nr. 99/44/EG) and the respective local regulations are applicable. Replaced parts become the property of IKEA.

**What will IKEA do to correct the problem?**

IKEA appointed service provider will examine the product and decide, at its sole discretion, if it is covered under this guarantee. If considered covered, IKEA Service Provider or its authorized service partner through its own service operations, will then, at its sole discretion, either repair the defective product or replace it with the same or a comparable product.

**What is not covered under this guarantee?**

- Normal wear and tear.
- Deliberate or negligent damage, damage caused by failure to observe operating instructions, incorrect installation or by connection to the wrong voltage, damage caused by chemical or electrochemical reaction, rust, corrosion or water damage including but not limited to damage caused by excessive lime in the water supply, damage caused by abnormal environmental conditions.
- Consumable parts including batteries and lamps.
- Non-functional and decorative parts which do not affect normal use of the appliance, including any scratches and possible color differences.
- Accidental damage caused by foreign objects or substances and cleaning or unblocking of filters, drainage systems or soap drawers.

- Damage to the following parts: ceramic glass, accessories, crockery and cutlery baskets, feed and drainage pipes, seals, lamps and lamp covers, screens, knobs, casings and parts of casings. Unless such damages can be proved to have been caused by production faults.
- Cases where no fault could be found during a technician's visit.
- Repairs not carried out by our appointed service providers and/or an authorized service contractual partner or where non-original parts have been used.
- Repairs caused by installation which is faulty or not according to specification.
- The use of the appliance in a non-domestic environment i.e. professional use.
- Transportation damages. If a customer transports the product to his home or another address, IKEA is not liable for any damage that may occur during transport. However, if IKEA delivers the product to the customer's delivery address, then damage to the product that occurs during this delivery will be covered by IKEA.
- Cost for carrying out the initial installation of the IKEA appliance.

However, if an IKEA appointed Service Provider or its authorized service partner repairs or replaces the appliance under the terms of this guarantee, the appointed Service Provider or its authorized service partner will reinstall the repaired appliance or install the replacement, if necessary. This does not apply within Ireland, customer should contact the local IKEA dedicated after sales line or the appointed Service Provider for further information.

These restrictions do not apply to fault-free work carried out by a qualified specialist using our original parts in order to adapt the appliance to the technical safety specifications of another EU country.

**How country law applies**

The IKEA guarantee gives you specific legal rights, which cover or exceed all the local legal demands.



However these conditions do not limit in any way consumer rights described in the local legislation.

### Area of validity

For appliances which are purchased in one EU country and taken to another EU country, the services will be provided in the framework of the guarantee conditions normal in the new country.

An obligation to carry out services in the framework of the guarantee exists only if the appliance complies and is installed in accordance with:

- the technical specifications of the country in which the guarantee claim is made;
- the Assembly Instructions and User Manual Safety Information.

### The dedicated AFTER SALES for IKEA appliances

Please don't hesitate to contact IKEA appointed After Sales Service Provider to:

- make a service request under this guarantee;
- ask for clarifications on installation of the IKEA appliance in the dedicated IKEA kitchen furniture;
- ask for clarification on functions of IKEA appliances.

To ensure that we provide you with the best assistance, please read carefully the Assembly Instructions and/or the User Manual before contacting us.

### How to reach us if you need our service



Please refer to the last page of this manual for the full list of IKEA appointed After Sales Service Provider and relative national phone numbers.

**i** In order to provide you a quicker service, we recommend to use the specific phone numbers listed on this manual. Always refer to the numbers listed in the booklet of the specific appliance you need an assistance for. Please also always refer to the IKEA article number (8 digit code) and 12 digit service number placed on the rating plate of your appliance.

**i** **SAVE THE SALES RECEIPT!**  
It is your proof of purchase and required for the guarantee to apply. The sales receipt also reports the IKEA name and article number (8 digit code) for each of the appliances you have purchased.

### Do you need extra help?

For any additional questions not related to After Sales of your appliances please contact your nearest IKEA store call centre. We recommend you read the appliance documentation carefully before contacting us.

**BELGIË - BELGIQUE - BELGIEN**

Telefoon/Numéro de téléphone/Telefon-Nummer:	026200311	
Tarief/Tarif/Tarif:	Lokaal tarief/Prix d'un appel local/Ortstarif	
Openingstijd:	Maandag - Vrijdag	8.00 - 20.00
Heures d'ouverture:	Lundi - Vendredi	8.00 - 20.00
Öffnungszeiten:	Montag - Freitag	8.00 - 20.00

**БЪЛГАРИЯ**

Телефонен номер:	02 4003536	
Тарифа:	Локална тарифа	
Работно време:	понеделник - петък	8.00 - 20.00

**ČESKÁ REPUBLIKA**

Telefonní číslo:	225376400	
Sazba:	Místní sazba	
Pracovní doba:	Pondělí - Pátek	8.00 - 20.00

**DANMARK**

Telefonnummer:	70150909	
Takst:	Lokal takst	
Åbningstid:	Mandag - fredag	9.00 - 21.00
	Lørdag	9.00 - 18.00
	(Åbent udvalgte søndage, se IKEA.dk)	

**DEUTSCHLAND**

Telefon-Nummer:	06929993602	
Tarif:	Ortstarif	
Öffnungszeiten:	Montag - Freitag	8.00 - 20.00

**ΕΛΛΑΔΑ**

Τηλεφωνικός αριθμός:	2109696497	
Χρέωση:	Τοπική χρέωση	
Ώρες λειτουργίας:	Δευτέρα - Παρασκευή	8.00 - 20.00

**ESPAÑA**

Teléfono:	913754126	
Tarifa:	Tarifa local	
Horario:	Lunes - Viernes	8.00 - 20.00
	(España Continental)	

**FRANCE**

Numéro de téléphone:	0170480513	
Tarif:	Prix d'un appel local	
Heures d'ouverture:	Lundi - Vendredi	9.00 - 21.00

**HRVATSKA**

<http://www.ikea.com>

**ÍSLAND**

Símanúmer:	5852409	
Kostnaður við símtal:	Almennt mínútuverð	
Opnunartími:	Mánudaga - Föstudaga	9.00 - 17.00

**ITALIA**

Telefono:	0238591334	
Tariffa:	Tariffa locale	
Orari d'apertura:	Lunedì - Venerdì	8.00 - 20.00

**LIETUVIŲ**

Telefono numeris:	(0) 520 511 35	
Skambučio kaina:	Vietos mokėstis	
Darbo laikas:	Nuo pirmadienio iki penktadienio	8.00 - 20.00

**MAGYARORSZÁG**

Telefon szám:	(06-1)-3285308	
Tarifa:	Helyi tarifa	
Nyitvatartási idő:	Hétfőtől Péntekig	8.00 - 20.00

**NEDERLAND**

Telefoon:	09002354532 en/of 0900 BEL IKEA	
Tarief:	15 cent/min., starttarief 4.54 cent en gebruikelijke belkosten	
Openingstijd:	Maandag t/m - Vrijdag	8.00 - 20.00
	Zaterdag	9.00 - 20.00
	Zondag	gesloten

**NORGE**

Telefon nummer:	23500112	
Takst:	Lokal takst	
Åpningstider:	Mandag - fredag	8.00 - 20.00

**ÖSTERREICH**

Telefon-Nummer:	013602771461	
Tarif:	Ortstarif	
Öffnungszeiten:	Montag - Freitag	8.00 - 20.00

**POLSKA**

Numer telefonu:	225844203	
Stawka:	Koszt połączenia według taryfy operatora	
Godziny otwarcia:	Poniedziałek - Piątek	8.00-20.00

**PORTUGAL**

Telefone:	213164011	
Tarifa:	Tarifa local	
Horário:	Segunda - Sexta	9.00 - 21.00

**REPUBLIC OF IRELAND**

Phone number:	016590276	
Rate:	Local rate	
Opening hours:	Monday - Friday	8.00 - 20.00

**ROMÂNIA**

Număr de telefon:	021 2044888	
Tarif:	Tarif local	
Orar:	Luni - Vineri	8.00 - 20.00

**РОССИЯ**

Телефонный номер:	84957059426	
Стоимость звонка:	Местная стоимость звонка	
Время работы:	Понедельник - Пятница	9.00 - 21.00
	(Московское время)	

**SCHWEIZ - SUISSE - SVIZZERA**

Telefon-Nummer/Numéro de téléphone/Telefono:	0225675345	
Tarif/Tarif/Tariffa:	Ortstarif/Prix d'un appel local/Tariffa locale	
Öffnungszeiten:	Montag - Freitag	8.00 - 20.00
Heures d'ouverture:	Lundi - Vendredi	8.00 - 20.00
Orario d'apertura:	Lunedì - Venerdì	8.00 - 20.00

**SLOVENSKO**

Telefónne číslo:	(02) 50102658	
Cena za hovor:	Cena za miestny hovor	
Pracovná doba:	Pondelok až piatok	8.00 - 20.00

**SRBIJA**

<http://www.ikea.com>

**SUOMI**

Puhelinnumero:	0981710374	
Hinta:	Yksikköhinta	
Aukioloaika:	Maanantaista perjantain	8.00 - 20.00

**SVERIGE**

Telefon nummer:	0775-700 500	
Taxa:	Lokal samtal	
Öppet tider:	Måndag - Fredag	8.30 - 20.00
	Lördag - Söndag	9.30 - 18.00

**UNITED KINGDOM**

Phone number:	02076601517	
Rate:	Local rate	
Opening hours:	Monday - Friday	9.00 - 21.00



